



(12) **United States Design Patent**
Tauchi et al.

(10) **Patent No.:** **US D802,545 S**
(45) **Date of Patent:** **** Nov. 14, 2017**

(54) **LOWER CHAMBER FOR A PLASMA PROCESSING APPARATUS**

6,068,548 A * 5/2000 Vote B24B 37/32
451/287
6,264,540 B1 * 7/2001 Fruitman B24B 37/32
451/288
D658,691 S * 5/2012 Suzuki D15/138
D693,782 S * 11/2013 Mori D13/182
D703,160 S * 4/2014 Tanimura D13/182
D716,240 S * 10/2014 Lau D13/182
D722,966 S * 2/2015 Smith D13/129
D734,377 S * 7/2015 Hirakida D15/138
D741,823 S * 10/2015 Tateno D13/182
D770,992 S * 11/2016 Tauchi D13/182

(71) Applicant: **Hitachi High-Technologies Corporation**, Minato-ku, Tokyo (JP)

(72) Inventors: **Susumu Tauchi**, Tokyo (JP); **Takashi Uemura**, Tokyo (JP); **Kohei Sato**, Tokyo (JP)

(73) Assignee: **Hitachi High-Technologies Corporation**, Tokyo (JP)

(**) Term: **15 Years**

Primary Examiner — Thomas Johannes
Assistant Examiner — Shawn T Gingrich

(21) Appl. No.: **29/544,071**

(74) *Attorney, Agent, or Firm* — Crowell & Moring LLP

(22) Filed: **Oct. 30, 2015**

(30) **Foreign Application Priority Data**

Jun. 12, 2015 (JP) 2015-013038

(51) **LOC (10) Cl.** **13-03**

(52) **U.S. Cl.**
USPC **D13/182**

(58) **Field of Classification Search**
USPC D13/118, 123, 154, 156, 173, 177, 182,
D13/184, 199; D8/70, 90, 396;
D15/126, 138, 139
CPC B24B 5/00; B24B 7/00; B24B 7/22; B24B
37/04; B24B 37/28; B24B 37/32; B24B
1/00; B24B 29/00; C30B 23/02; H01L
21/304; H01L 21/67; H01L 21/68; H01L
21/00; H01L 21/32; Y10S 41/139; C23C
16/00; C23C 16/45; C25D 17/00; H01R
3/00

See application file for complete search history.

(56) **References Cited**

U.S. PATENT DOCUMENTS

4,319,432 A * 3/1982 Day B24B 37/32
451/269
D404,369 S * 1/1999 Kawachi D13/182

(57) **CLAIM**

The ornamental design for a lower chamber for a plasma processing apparatus, as shown and described.

DESCRIPTION

FIG. 1 is a front, top and right side perspective view of a lower chamber for a plasma processing apparatus according to the design;
FIG. 2 is a front elevational view thereof;
FIG. 3 is a rear elevational view thereof;
FIG. 4 is a left side elevational view thereof;
FIG. 5 is a right side elevational view thereof;
FIG. 6 is a top plan view thereof;
FIG. 7 is a bottom plan view thereof;
FIG. 8 is a cross-sectional view taken along line 8-8 of FIG. 6;
FIG. 9 is a cross-sectional view taken along line 9-9 of FIG. 6; and,
FIG. 10 is a partially enlarged view taken along line 10-10 of FIG. 8.

1 Claim, 6 Drawing Sheets

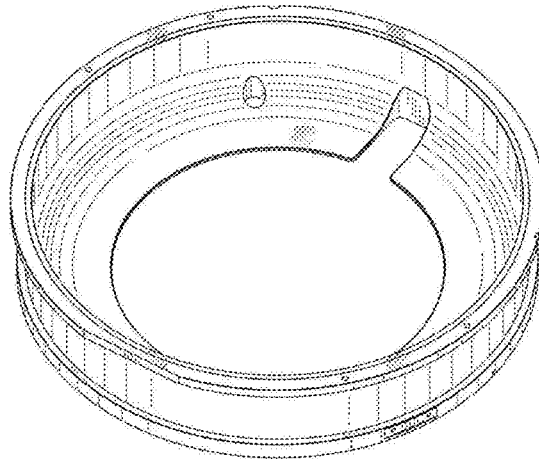

(56)

References Cited

U.S. PATENT DOCUMENTS

D775,710	S *	1/2017	Kim	D22/137
2004/0077167	A1 *	4/2004	Willis	B24B 37/32
					438/689
2005/0191947	A1 *	9/2005	Chen	B24B 37/32
					451/41
2007/0224864	A1 *	9/2007	Burns	B24B 37/32
					439/164
2012/0263569	A1 *	10/2012	Priddy	C30B 23/02
					414/800

* cited by examiner

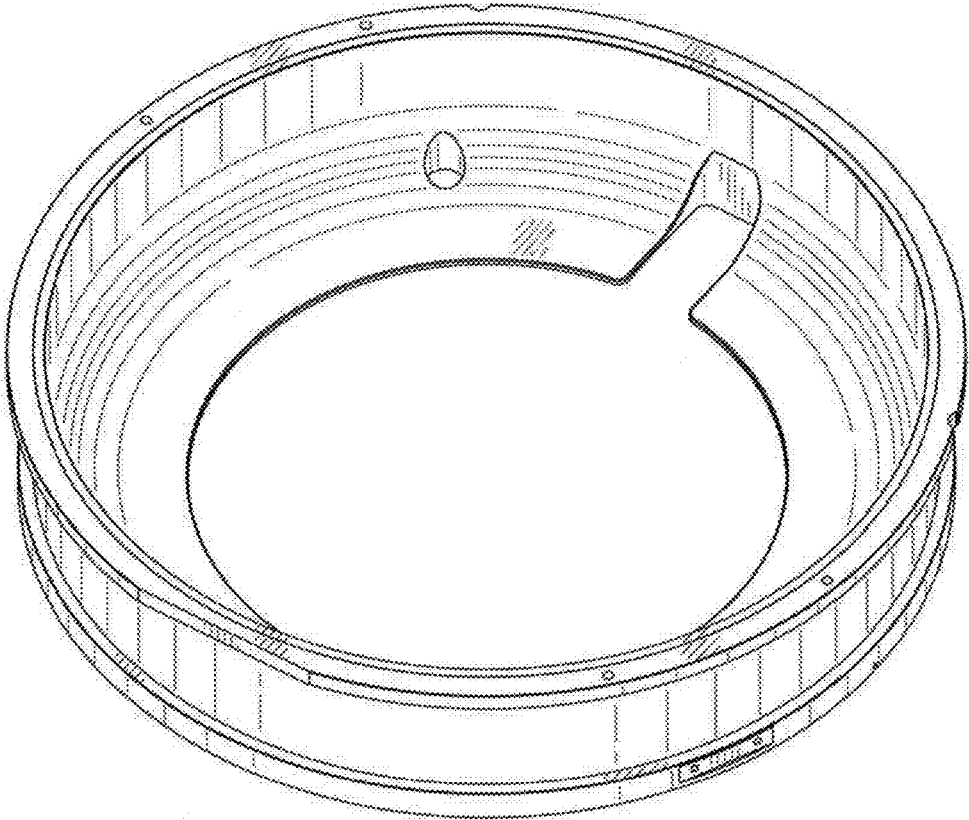

FIG. 1

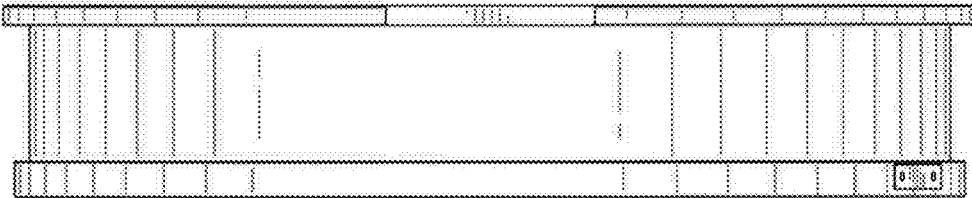

FIG. 2

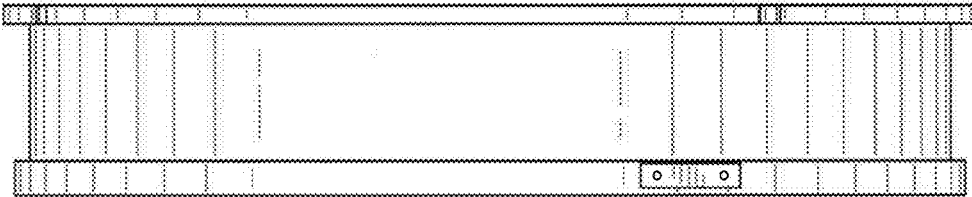

FIG. 3

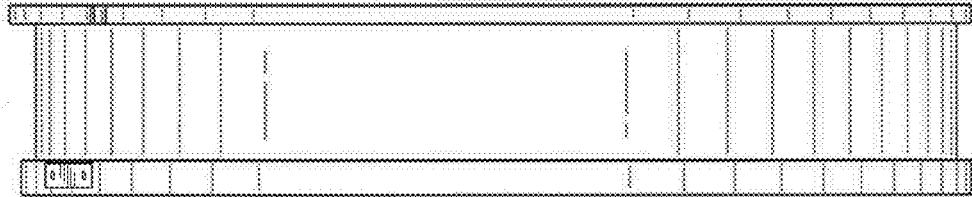

FIG. 4



FIG. 5

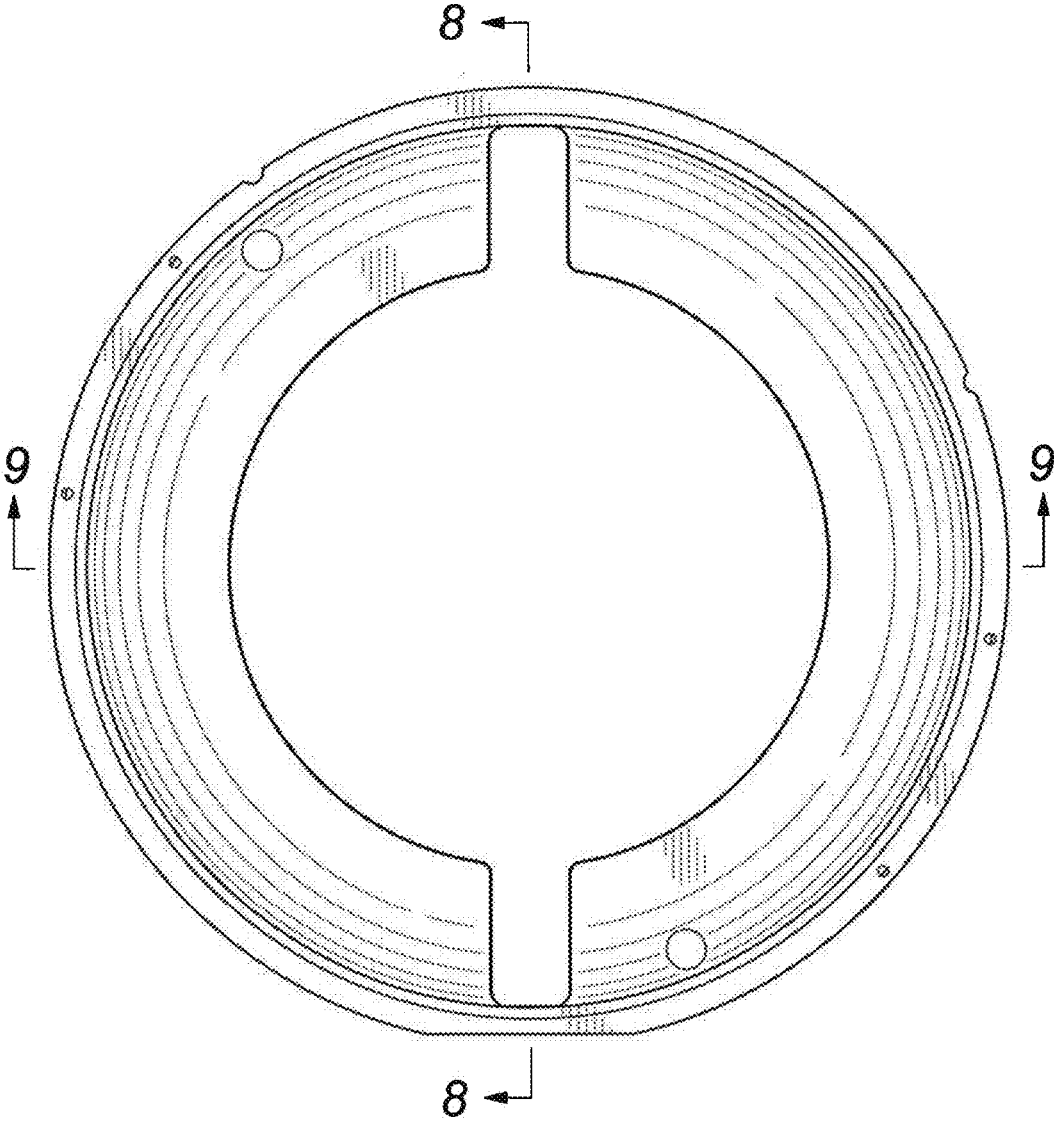

FIG. 6

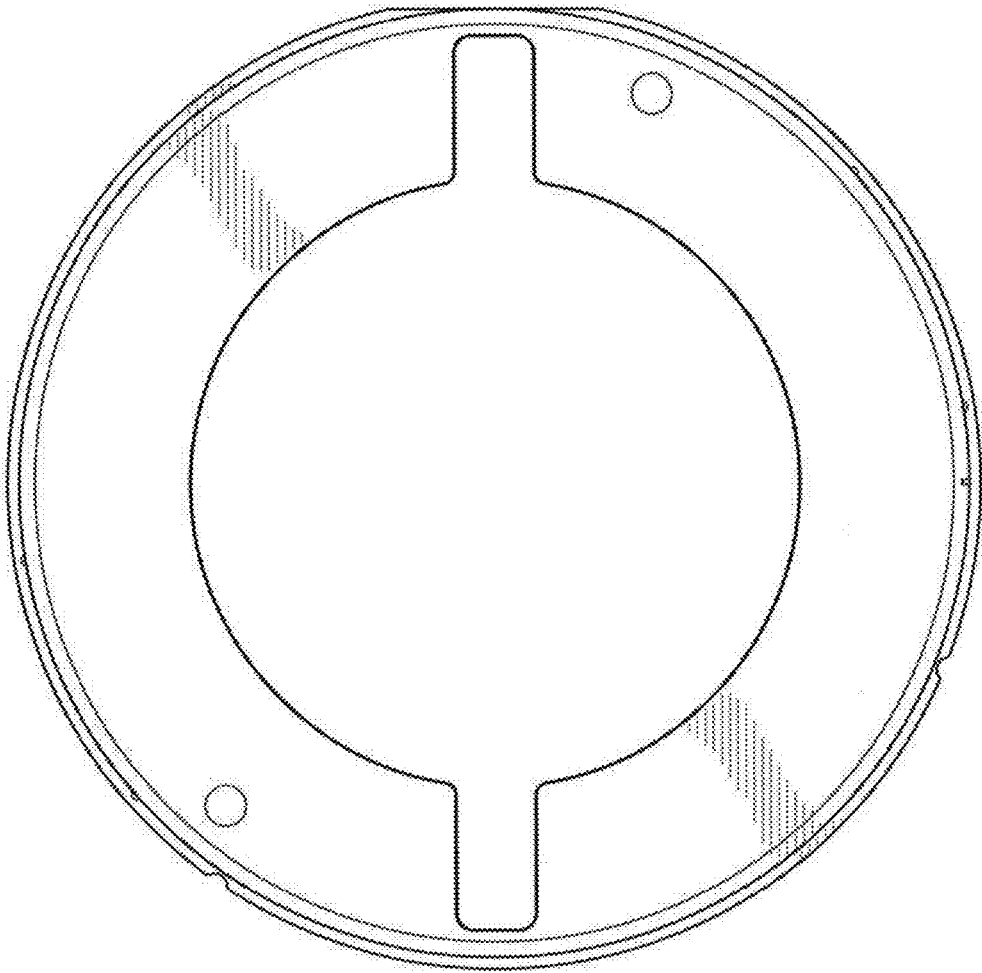

FIG. 7

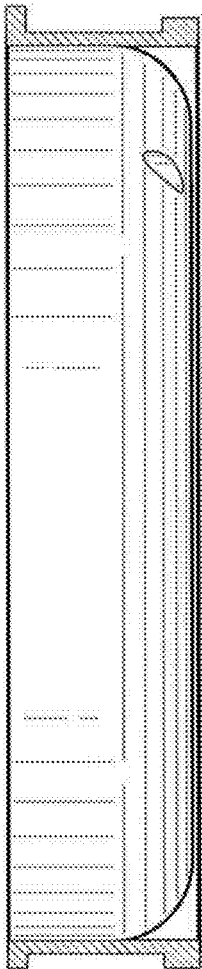

FIG. 8

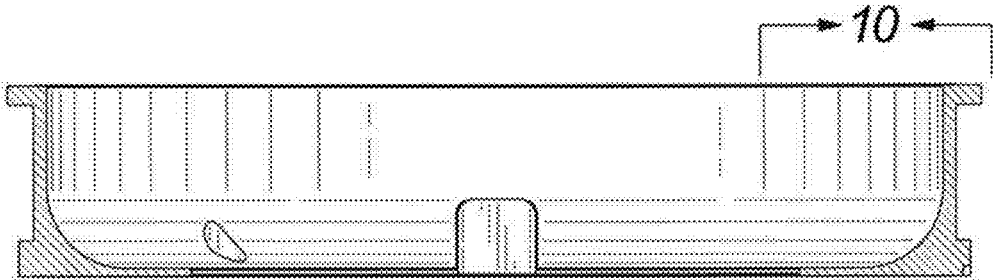

FIG. 9

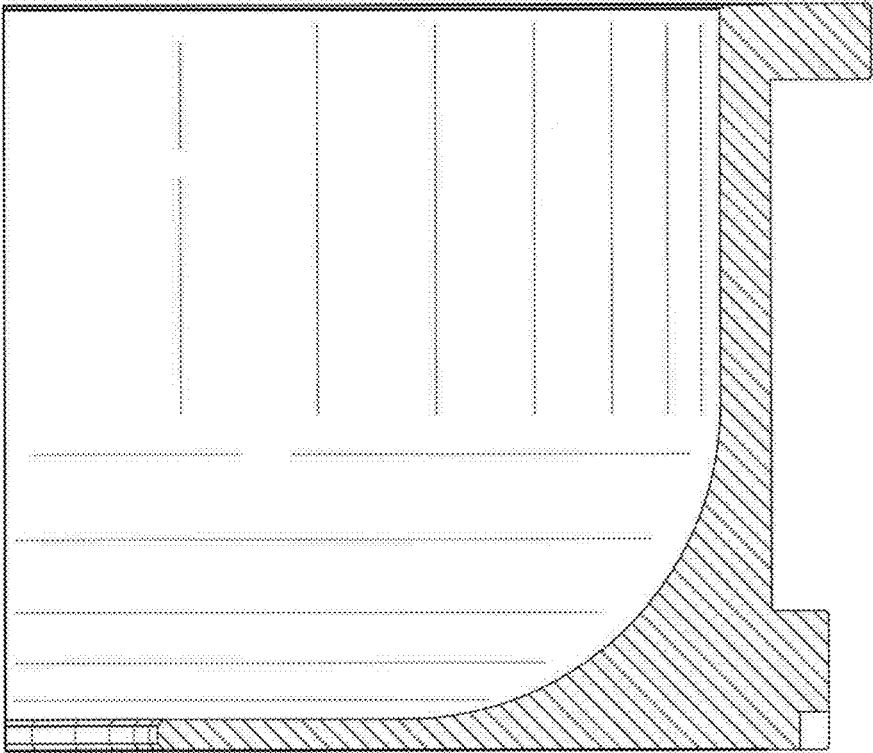

FIG. 10