

(19) AUSTRALIAN PATENT OFFICE

(54) Title
Portable x-ray device

(51)⁶ International Patent Classification(s)
H05G 1/10 (2006.01) 20060101AFI2006082
H05G 1/10 5BHAU
PCT/US2005/005712

(21) Application No: 2005216184 (22) Application Date: 2005 .02 .18

(87) WIPO No: W005/081956

(30) Priority Data

(31) Number	(32) Date	(33) Country
60/546,575	2004 .02 .20	US

(43) Publication Date : 2005 .09 .09

(71) Applicant(s)
Aribex, Inc.

(72) Inventor(s)
Turner, D. Clark

(74) Agent/Attorney
Davies Collison Cave, 255 Elizabeth Street, Sydney, NSW, 2000

(56) Related Art
US4646338
US20050018817
US20040146142
US4979198
US5514873
US5631943
US4840471
US2063329
US5077771
US4170735

(19) World Intellectual Property Organization
International Bureau



(43) International Publication Date
9 September 2005 (09.09.2005)

PCT

(10) International Publication Number
WO 2005/081956 A3

- (51) International Patent Classification: **H05G 1/10**
- (21) International Application Number: PCT/US2005/005712
- (22) International Filing Date: 18 February 2005 (18.02.2005)
- (25) Filing Language: English
- (26) Publication Language: English
- (30) Priority Data: 60/546,575 20 February 2004 (20.02.2004) US
- (71) Applicant (for all designated States except US): **ARIBEX, INC.** [US/US]; 751 South 400 East, Orem, UT 84097 (US).
- (72) Inventor; and
- (75) Inventor/Applicant (for US only): **TURNER, D., Clark** [US/US]; 9557 South 6200 West, Payson, UT 84651 (US).
- (74) Agents: **HORTON, Kenneth, E. et al.**; Kirton & McConkie, P.O. Box 45120, Salt Lake City, UT 84145-0120 (US).
- (81) Designated States (unless otherwise indicated, for every kind of national protection available): AE, AG, AL, AM, AT, AU, AZ, BA, BB, BG, BR, BW, BY, BZ, CA, CH, CN, CO, CR, CU, CZ, DE, DK, DM, DZ, EC, EE, EG, ES, FI, GB, GD, GE, GH, GM, HR, HU, ID, IL, IN, IS, JP, KE, KG, KP, KR, KZ, LC, LK, LR, LS, LT, LU, LV, MA, MD, MG, MK, MN, MW, MX, MZ, NA, NI, NO, NZ, OM, PG, PH, PL, PT, RO, RU, SC, SD, SE, SG, SK, SL, SM, SY, TJ, TM, TN, TR, TT, TZ, UA, UG, US, UZ, VC, VN, YU, ZA, ZM, ZW.
- (84) Designated States (unless otherwise indicated, for every kind of regional protection available): ARIPO (BW, GH, GM, KE, LS, MW, MZ, NA, SD, SI, SZ, TZ, UG, ZM, ZW), Eurasian (AM, AZ, BY, KG, KZ, MD, RU, TJ, TM), European (AT, BE, BG, CH, CY, CZ, DE, DK, EE, ES, FI, FR, GB, GR, HU, IT, IS, IT, LT, LU, MC, NL, PL, PT, RO, SE, SI, SK, TR), OAPI (BF, BJ, CF, CG, CI, CM, GA, GN, GQ, GW, ML, MR, NI, SN, TD, TG).
- Published:
— with international search report

[Continued on next page]

(54) Title: PORTABLE X-RAY DEVICE

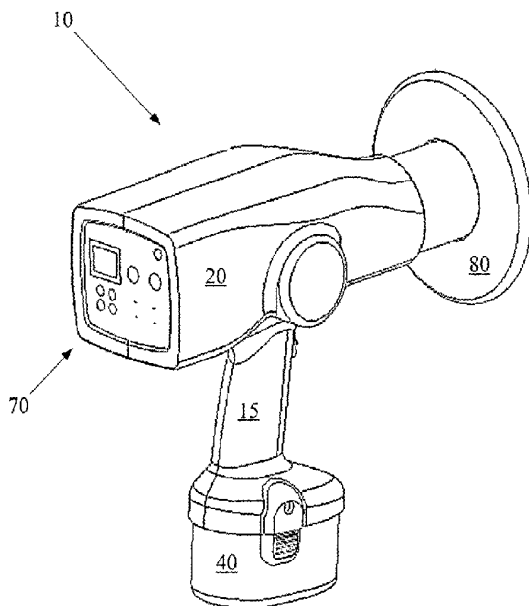

(57) Abstract: Portable x-ray devices and methods for using such devices are described. The devices have an x-ray tube (30) powered by an integrated power system (40). The x-ray tube is shielded with a low-density insulating material (80) containing a high-Z substance. The devices can also have an integrated display component (70). With these components, the size and weight of the x-ray devices can be reduced, and the portability of the devices enhanced. Thus, the portable x-ray devices are especially useful for applications where portability is an important feature such as in field work, remote operations, and mobile operations such as nursing homes, home healthcare and teaching classrooms. This portability feature can be particularly useful in multi-suite medical and dental offices where a single x-ray device can be used in multiple offices instead of single using an x-ray device in each office.

WO 2005/081956 A3



(88) Date of publication of the international search report:
4 May 2006

For two-letter codes and other abbreviations, refer to the "Guidance Notes on Codes and Abbreviations" appearing at the beginning of each regular issue of the PCT Gazette.

PORTABLE X-RAY DEVICECROSS-REFERENCE TO RELATED APPLICATION

This application claims priority of U.S. Patent Application Serial No. 60/546,575, filed on February 20, 2004, the entire disclosure of which is incorporated herein by reference.

FIELD OF THE INVENTION

The invention generally relates to x-ray devices and methods for using the same. More particularly, the invention relates to x-ray tubes used in x-rays devices. Even more particularly, the invention relates to portable x-ray devices that contain an integrated power system, methods for using such portable x-ray devices, and systems containing such portable x-ray devices.

BACKGROUND OF THE INVENTION

Typical x-ray tubes and x-ray devices (device containing x-ray tubes) have been known and used for some time. Unfortunately, they are usually bulky and are powered by heavy, high-voltage power supplies that restrict mobility. As well, they are often difficult and time-consuming to use. In many instances, a sample for analysis must be sent to an off-site laboratory for analysis by the x-ray device.

These limitations can be very inconvenient for many popular uses of x-ray devices containing them. Such uses include x-ray fluorescence (XRF) of soil, water, metals, ores, well bores, etc., as well as diffraction and plating thickness measurements. Typical x-ray imaging

applications require the sample to be imaged to be brought to the x-ray device. These limitations have led to an increased interest in making x-ray devices portable. See, for example, U.S. Patent Nos. 6,661,876, 6,459,767, 6,038,287, and 6,205,200; U.S. Published Patent Applications 2003/0048877, 2003/0002627, and 2003/0142788; and European Patent Nos. EP0946082, EP0524064, EP0247758, EP0784965, and EP0488991; the entire disclosures of which are incorporated herein by reference.

Many of these existing designs increase the portability of x-ray devices. At the same time, however, these designs are limited for several reasons. First, most of the designs are not truly portable since they have an external power source (i.e., require utility-supplied line voltage). Second, while some of the portable designs, especially the XRF systems, have internal or "integrated" power supplies, they don't have the high x-ray tube current load that is often necessary for x-ray imaging. For example, energy-dispersive XRF typically requires x-ray beam currents of less than 1 milliamperere while x-ray imaging typically requires greater than about 2 milliamperes. Third, high-quality imaging displays for displaying the results of the x-ray analysis are not present. Finally, the radiation shielding for the x-ray tubes usually comprises lead, which is quite heavy and limits the portability of the device.

A further limitation on design of the increased portability is the image collection and display components. Many of the portable designs have the image collection component and the image display component external to the chassis or housing containing the x-ray tube. Such a configuration, however, increases the size of the device and the number of system components, and consequently decreases the portability of the device.

2005216184 23 Jun 2008

SUMMARY OF THE INVENTION

The invention relates to portable x-ray devices and methods for using such devices. The devices have an x-ray tube powered by an integrated power system. The x-ray tube is shielded with a low-density insulating material containing a high-Z substance. The devices
5 can also have an integrated display component. With these components, the size and weight of the x-ray devices can be reduced, and the portability of the devices enhanced. Thus, the portable x-ray devices are especially useful for applications where portability is an important feature such as in field work, remote operations, and mobile operations such
10 nursing homes, home healthcare, teaching classrooms. This portability feature can be particularly useful in multi-suite medical and dental offices where a single x-ray device can be used in multiple offices instead of single using an x-ray device in each office.

In one aspect there is provided a portable x-ray device, comprising:

a housing with a first portion that contains an x-ray source that is powered by an integrated power system and the housing also contains an internal power source;
15 wherein the x-ray device has a high current load sufficient for radiographic imaging.

In one aspect there is provided a handheld x-ray device, comprising:

a housing with a first portion that contains an x-ray source shielded with a low-density insulating material and that is powered by an integrated power system; and
the housing also has a second portion that contains an internal power source, the
20 second portion being removably attached to the first portion so that when the second portion is removed from the first portion, no power is generated for the x-ray source; wherein the x-ray device has a high current load for radiographic imaging.

2005216184 23 Jun 2008

In one aspect there is provided a system for x-ray analysis, the system containing a portable x-ray device with a housing containing an x-ray source that is powered by an integrated power system which includes a plurality of power supplies with each power supply providing a power ranging from about 20kV to about 50kV and the integrated power system provides a high current load sufficient for radiographic imaging wherein the housing also contains an internal power source.

In one aspect there is provided a method for making a portable x-ray device with a high current load, the method comprising:

- 10 providing an x-ray source in a first portion of a housing;
- providing an integrated power system in the first portion of the housing and connecting it to the x-ray source;
- providing an internal power source in a removable, second portion of the housing;
- and
- 15 connecting the second portion to the first portion.

In one aspect there is provided a method for analysis, comprising:

- providing a material to be analyzed;
- providing a portable x-ray device with a high current load, the device having a housing that contains an x-ray source that is powered by an integrated power system and
- 20 the housing also contains an internal power source; and
- actuating the x-ray source so that an x-ray impinges on the material.

In one aspect there is provided a method for dental imaging, comprising:

- providing a tooth of a patient to be analyzed;

2005216184 23 Jun 2008

providing a portable x-ray device with a high current load for radiographic imaging, the device having a housing that contains an x-ray source that is powered by an integrated power system and the housing also contains an internal power source; and actuating the x-ray source so that x-rays impinge on that tooth.

5

In one aspect there is provided a portable x-ray device, comprising:
a housing having a first portion that contains an x-ray source that is powered by an integrated power system which includes a plurality of power supplies with each power supply providing a power ranging from about 20kV to about 50kV and the power system provides a current sufficient for radiographic imaging;

10

the housing also having a second portion that contains an internal power source and the second portion is removably attached to the first portion so that when the second portion is removed from the first portion, no power is generated for the x-ray source; and

15

a display integrated into the first portion of the housing to display a radiographic image.

BRIEF DESCRIPTION OF THE DRAWINGS

The following description of the invention can be understood in light of the
20 Figures, in which:

Figures 1-2 depict the x-ray device in one aspect of the invention;

Figure 3 depicts the x-ray device in another aspect of the invention;

Figure 4 depicts the x-ray device in another aspect of the invention;

Figure 5 depicts the x-ray tube and power supply of the x-ray device in one
25 aspect of the invention;

Figures 6-7 depict the power source of the x-ray device and method for connecting the power source to the x-ray device in one aspect of the invention;

Figure 8 depicts the x-ray tube of the x-ray device in one aspect of the invention;
and

Figure 9 depicts a conventional x-ray tube in a conventional configuration.

Figures 1-9 illustrate specific aspects of the invention and are a part of the specification. In the Figures, the thickness and configuration of components may be exaggerated for clarity. The same reference numerals in different drawings represent the same component. Together with the following description, the Figures demonstrate and explain the principles of the invention.

DETAILED DESCRIPTION OF THE INVENTION

The following description provides specific details in order to provide a thorough understanding of the invention. The skilled artisan, however, would understand that the invention can be practiced without employing these specific details. Indeed, the invention can be practiced by modifying the illustrated method and resulting product and can be used in conjunction with apparatus and techniques conventionally used in the industry. While the invention is described for use in x-ray imaging for dental purposes, it could be used in other medical applications such as medical imaging, veterinary, and bone densitometry. As well, it could be used for non-dental and non-medical applications such as industrial imaging, metal

fatigue inspections, weld-inspection for cracks/voids and pipes, for security inspections allowing random inspection of parcels and carry-on baggage, and the like.

As described above, the invention includes a portable x-ray device that is used primarily for remote and/or applications, including in multi-suite locations. The x-ray device can be designed to be either handheld or temporarily fixed to a given location, such as a tripod-mount operation. As well, the invention could be mounted on any other semi-stable apparatus, such as an articulating arm or C-arm as commonly used in radiology applications and described in the publications mentioned above. The x-ray device is portable in that it can be transported by hand carrying it from one location to a second location without support by any mechanical apparatus. Most importantly, because of its integrated power system, the location of use can be independent of any external fixed power source, such as utility-supplied AC voltage commonly available in the home or office. This independence from external power source is a defining feature of the portable x-ray device described above.

As shown in Figures 1-2, the x-ray device 10 of the invention contains a housing or chassis 20 to contain all the internal components of the device. The housing 20 encloses an x-ray tube 30 for producing the x-rays. The x-ray device 10 contains a power system (including power source 40) to provide power for the device 10 and means for sensing the x-rays, such as film, CCD sensors, or imaging plates (not shown). The x-ray device 10 also contains means for displaying the results of the analysis such as an integrated image display screen 60 (shown in Figure 4); control means such as controller 70; and radiation shielding 80 to shield the operator of the device from backscattered radiation from the sample. The x-ray device 10

also contains any other components known in the art for efficient operation (such as x-ray collimator 32), including those components described in the documents mentioned above.

The x-ray device 10 contains a unique system for providing power to the x-ray device. The power system of the x-ray device comprises a power source 40, power supply 34, and conversion means. The power source 40 used in the x-ray device of the invention can be any known in the art that can supply the desired amount of power, yet fit within the space limitations of the x-ray device. In one aspect of the invention, the power source comprises a battery, such as a 14.4V NiCd battery pack. The power source can be recharged by any suitable means, such as by connection to an appropriate voltage when using batteries that are re-chargeable.

In one aspect of the invention, the power source 40 is removable from the remainder of the x-ray device 10. In this aspect of the invention, the power source 40 comprises mechanical and electrical means for connecting the power source 40 to the x-ray device 10. The electrical and mechanical connection means can be any of those known in the art. As depicted in Figure 6, the electrical connection means can comprise an extension member 41 with an electrical connector 42 contained in an upper portion thereof. The mechanical connection means comprises a release mechanism 43a.

As shown in Figure 7, the x-ray device 10 contains a locking mechanism 43b. To connect the power source 40 to the x-ray device 10, the power source 40 is gently pushed into the bottom of the handle 15 of the x-ray device 10. When completely connected, the electrical connector 42 connects with the internal electronics of the x-ray device 10. The locking

mechanism 43b is automatically engaged to retain the power source 40 connected to the x-ray device 10 in this position. To remove the power source 40, the release mechanism 43a is actuated to unlock the locking mechanism 43b, and the power source 40 can be gently slid out from the handle 15.

The power source 40 is electrically connected to the conversion means using any connection means known in the art, including those described in the publications above. The conversion means converts the initial voltage supplied by the power source 40 to a converted voltage that is provided to the power supply 34. The conversion means generally converts the 14.4V (or similar voltage) provided by the power source 40 to a voltage ranging from about 80 to about 200V. In one aspect of the invention, the initial voltage is converted to a converted voltage of about 100V. Any conversion means known in the art that operates in this manner can be used in the invention, including the power management boards 36.

The conversion means is electrically connected to the power supply 34. The power supply 34 steps up the converted voltage (i.e., the 100V) provided by the conversion means to a voltage that can be used by the x-ray tube 30. The power produced by the power supply 34 and input into the x-ray tube 30 via connection 35 (shown in Figure 8) depends on the power needed to operate the x-ray tube, and the maximum power available from the power source. Generally, the power provided by the power supply 34 to the x-ray tube 30 can range from about 20 to about 150 kV. Typically, this power provided by the power supply can range from about 40kV to about 100kV.

In one aspect of the invention, the power provided by the power supply is provided by a plurality of individual power supplies. The number of individual power supplies used depends on the voltage needed for the x-ray tube, the space needed for the power supply 34, the total power available from the power source, and the number of electron-accelerating grids in the x-ray tube. In one aspect of the invention, the plurality of individual power supplies is two (as represented in Figure 5 by 45, 46) where 45 supplies positive voltage to the anode and 46 supplies negative voltage to the cathode.

The power provided by each individual power supply depends on the number of individual power supplies used, the maximum power available from the power source, and the heat-dissipating capability of the x-ray tube. Generally, the power supplied by each individual power supply is the total power needed to operate the x-ray tube divided by the number of individual power supplies. For example, the power provided by each individual power supply (when there are 2) can range from about 20kV to about 50kV. In one aspect of the invention, the power provided by each individual power supply (when there are 2) is about +35 kV and -35kV. In this embodiment, the +35 kV is attached to the anode of the x-ray tube and the -35 kV is attached to the cathode of the x-ray tube. A filament transformer is included in the cathode power supply to provide current to the x-ray tube filament and generate an electron beam at the cathode of the tube. The total power produced by the power supply is the therefore sum of the individual anode power supply and the individual cathode power supply.

When such individual low voltage power supplies are used, the x-ray tube 30 of the invention becomes more portable. Conventional x-ray tubes operate at much higher voltages

in the range of 70 kV and higher. Because of these high voltages, and the need for the high voltage standoff, the conventional x-ray tube 300 is often encased in insulating oil 302 (or a similar material) within a liquid-tight case 306 as shown in Figure 9. The oil 302 also has the advantage of dissipating the high temperatures that existed during operation. By splitting the needed operation voltage into 2 (or more) individual power supplies, the individual power supplies only need to provide (and also stand off) half of the higher voltage.

With these lower voltages, the x-ray tube 30 of the invention can be encapsulated in materials other than high-density oil. These other materials need only insulate proportionately to the reduced voltage, i.e., these other materials need only insulate half as much as oil since the voltage produced is about half of that conventionally used. Any known material that can insulate in this manner can be used in the invention, including low-density materials like insulating gel, silicone rubber, epoxy, or combinations thereof. The insulating material is provided in a layer 33 that substantially encapsulates the x-ray tube 30 except for that portion of the tube where x-rays are actually emitted by the tube (i.e., into the x-ray collimator 32).

The thickness of the layer of insulating material 33 need only be sufficient for the purpose indicated above. Generally, the thickness of the insulating material can range from about ¼ inch to about 1 inch. In one aspect of the invention, such as where silicone rubber is used, the thickness of the insulating material can range from about 1/3 inch to about ½ inch. In another aspect of the invention, the insulating material comprises a dual-layer around the x-ray tube with the first layer comprising one of the insulating materials and the second layer comprising another of the insulating materials.

Eliminating the need to use the high-density oil provides a significant reduction in the weight of the unit. An added advantage is that there is no need for a liquid-tight case 306 to hold the liquid oil 302. Indeed, when a solid material is used such as silicone rubber, there is no need for any case, even though one can optionally be used. In one aspect of the invention by removing the case, and instead using silicon rubber that is conformal with the x-ray tube, the total volume of the insulating material is reduced significantly.

As shown in Figure 9, conventional x-ray tubes 300 also contain a shielding to absorb stray x-rays that are emitted from the x-ray tube. The shielding usually was made of lead and incorporated into the liquid-tight case. Lead was used because of its excellent x-ray absorption properties. But lead shielding is quite heavy and consequently limits the portability of the x-ray device. With the x-ray device of the invention, this lead shielding has been eliminated, thereby increasing the portability by reducing the need for an additional component in the x-ray device. Instead, the insulating material (i.e., silicone rubber) has dispersed within it a high-Z material. The high-Z material absorbs any stray x-rays that are emitted. Any high-Z material known in the art can be used, including compounds of Pb, W, Ta, Bi, Ba, or combinations thereof.

The concentration of the high-Z material in the insulating material need only be sufficient to absorb the expected amount of stray x-rays. Typically, the concentration of the high-Z material can range from about 30 wt% to about 60 wt%. In one aspect of the invention, the concentration of the high-Z material can range from about 45 wt% to about 50 wt%. In one aspect of the invention, the insulating material also contains substances that are known to

optimize the thermal conductivity, such as metallic particles, or inclusions of high-thermal-conductivity materials.

The x-ray device of the invention optionally contains shielding 80 for the operator. When in operation, x-rays can often backscatter from the object being analyzed, such as the teeth of a patient, and strike the operator. The shielding 80 is used to protect the operator from such aberrant radiation. In one aspect of the invention, the shielding used is a Pb-filled acrylic radiation scatter shield.

The x-ray device of the invention also contains control means for operating the x-ray device. Any controls known in the art can be used in the control means of the invention. Examples of such controls include up and down arrow membrane switches with an LED readout to adjust exposure time. Indicators can include "power on," "start," and "x-rays on" LEDs. In the aspect of the invention illustrated in Figure 1, the control means (controller 70) is integrated into the housing 20 of the device. In another aspect of the invention, the control means (such as controller 76) is external to the device and is connected to remainder of the device using any known electronic connection, such as cable 72 (See Figure 3). In either instance, the control means also contains a trigger 74 that is incorporated into the handle 15 and used by the operator to begin (and conclude) the x-ray exposure.

The invention also contains means for sensing the x-rays. Any sensing means known in the art that is sensitive to x-ray radiation can be used in the invention. Examples of such sensing means include x-rays receptors, x-ray film, CCD sensors, CMOS sensors, TFT

sensors, imaging plates, and image intensifiers. In one aspect of the invention, a CCD sensor is used as the sensing means in the x-ray devices of the invention.

The x-ray device may also contain means for displaying the x-rays detected by the detecting means. Any display means that displays the detected x-rays in a manner that can be understood by the operator of the device can be used for the invention. Examples of displaying means that can be used include film, imaging plates, and digital image displays such as cathode ray tubes (CRT) or liquid crystal display (LCD) screens. In one aspect of the invention, the display means can be used as a densitometer for the x-ray absorption.

In one aspect of the invention, the display means is integrated into the housing of the x-ray device. Such integration, however, will limit the size of the display means since too large a display means will detract from the portability of the device. In this aspect of the invention, any small display means with sufficient resolution can be used in the invention, including liquid crystal display (LCD) screens 60.

In another aspect of the invention, the display means are located external to the x-ray device. In this aspect, a separate imaging plate (such as a CMOS or TFT plate) for larger features (such as medical or veterinary imaging) can be used. The separate imaging plate can be connected to the remainder of the x-ray device as known in the art.

In one aspect of the invention, the x-ray device 10 can contain both an integrated sensing means (such as a CCD sensor) and an integrated display means (such as the LCD screen 60) to minimize the size and optimize the portability of the x-ray device. These two components can be used to temporarily store images in the x-ray device. Once the storage capacity for these

temporary images has been reached, an optional wired or wireless connection can then provide seamless update to an external electronic system, such as a permanent database or a personal computer as known in the art. The wired or wireless connection can be made as known in the art. In one aspect of the invention, this connection is wireless since it provides true portability and freedom from line voltage.

The x-ray device of the invention can be made in any manner that provides the device with the components in this configuration described above. The housing, x-ray tube, sensing means, display means, control means, radiation shielding, power source, and conversion means can be provided as known in the art and as described in the publications disclosed above. The insulating material can be made by mixing the needed amount of high-Z substance (such as an oxide of a heavy metal) into the insulating material (such as the silicone potting material when the A and B parts of the silicone are mixed together). The resulting combination is thoroughly mixed, and then uniformly provided around the x-ray tube, such as by pouring into in an encapsulating mold. In this way, the insulating material containing the high-Z substance is uniformly distributed throughout the layer surrounding the x-ray tube.

When making the power supply, the process will be illustrated with two individual power supplies. Each power supply is configured so that the grounded ends of each power supply are located near the center of the x-ray tube. The positive voltage from one supply is provided to one side of the x-ray tube, and the negative voltage from the other supply is provided to other end of the x-ray tube. In this configuration, the maximum voltage (i.e., the sum of both) can be isolated from each individual power supply along the full length of the x-ray tube and the

isolation from ground only needs to be $\frac{1}{2}$ of the total voltage. Consequently, the insulating paths need only be $\frac{1}{2}$ the length.

The x-ray device can be operated in any manner that provides a radiographic image. In one aspect of the invention, the x-ray device of the invention can be operated by first actuating the appropriate button on the control means to turn on the device. After setting the exposure time, an "enable" button is pressed. This "enable" acts as a safety switch, preventing initiation of the x-ray exposure until the operator has positioned the instrument in the correct location and prepares to pull the trigger.

Then, on pulling the trigger (or pressing the "start" button) the high voltage (HV) supplied by the power supply 34 will increase up to about 70kV (i.e., one power supply at about +35kV and the other at about -35kV). When this HV level is reached, the filament will energize at its full setpoint to supply the needed emission current to the x-ray tube. The filament will remain at this level for the time designated by the operator (i.e., by using the controls). The start indicator in the LED of the control means can illuminate upon pressing the trigger. The "x-rays on" indicator in the LED of the control means can illuminate during the entire time that the emission current for the x-ray tube is present. Additionally, an audible signal can be used to indicate that the x-rays are being emitted.

During exposure after pressing the trigger 74, x-rays are emitted from the x-ray tube 30 and strike the object being analyzed, i.e., the teeth of a patient when the x-ray device is being used for dental purposes. To meet x-ray equipment standards, the button or trigger 74 must be held down during the full length of the exposure. During exposure, the x-rays are used for

analysis of the object as known in the art by using the sensing means. The operator can then view the results of the analysis in the display means and optionally download the images to an external storage device.

Following the exposure of a patient with the x-rays, the filament will turn off (along with the "x-rays on" indicator) and the HV will ramp down. Once the HV is off, the start indicator in the LED of the controller will turn off and the x-ray device will return to a standby condition. In one aspect of the invention, the operator may need to re-enter the exposure time before starting the next exposure. This re-entering process can be accomplished with a "ready" indicator in the LED of the control means after the exposure time has been set.

The x-ray device of the invention can be modified to contain additional optional features, including any of those described in the publications mentioned above. For example, to increase battery life, the x-ray device can contain an automatic shut off feature that shuts the device off after 2 minutes without an x-ray exposure. Another feature that can be added, for example, is to manufacture the housing or chassis 20 of a high-impact material (such as ABS or a plastic alloy of ABS and other materials, designed for high-impact resistance) to reduce the risk of damage.

The x-ray device of the invention can also be made as part of a system for x-ray analysis. The system could contain any components that aid in the operation of the x-ray device or the x-ray analysis, including those mentioned above such as an external means for storing the radiographic images. As well, the system could also include a hard-side carrying case, an "industrial strength" tripod, a 3 meter long umbilical cord to a remote control panel 76, or the

like. The system could also contain a back-up power source 40. Finally, the system could also contain any of those components described in the publications mentioned above.

Using the x-ray device of the invention provides several improvements over conventional devices. First, the x-ray device of the invention contains an integrated power system. The power system can be battery-operated, yet still provide a continuous high voltage, rather than Marx generators (pulsed) or capacitively-pulsed systems. Thus, the x-ray device can maintain a continuous DC high voltage supply and can generate a high voltage for a few seconds with each high current discharge. The high storage capacity provided by the batteries allows hundreds of discharges, anywhere from about 10 to about 20 amps for a few seconds. For most applications, including for dental purposes, the x-ray devices of the invention need less than a second for each exposure.

Most conventional x-ray devices, however, have external power supplies. Those conventional x-ray devices that do have integrated power supplies, still don't have the high current load described above. Thus, the power system of the invention can provide a constant radiation output and improved image quality while reducing the x-ray dosage to which the object (i.e., patient) is exposed.

Another improvement in the x-ray devices of the invention are in the shielding for the x-ray tubes. Conventional x-ray tubes are shielded with a liquid oil encasement and lead shielding, both of which are bulky and heavy. Both of these components are eliminated in the x-ray tube shielding of the invention. Instead, the shielding of the invention contains a low-

2005216184 23 Jun 2008

density insulating material that contains high-Z substances. This configuration leads to reduced material count and generally lower weight.

In addition to any previously indicated variation, numerous other modifications and alternative arrangements may be devised by those skilled in the art without departing from the spirit and scope of the invention and appended claims are intended to cover such modifications and arrangements. Thus, while the invention has been described above with particularity and detail in connection with what is presently deemed to be the most practical and preferred aspects of the invention, it will be apparent to those of ordinary skill in the art that numerous modifications, including but not limited to, form, function, manner of operation and use may be made without departing from the principles and concepts set forth herein.

Throughout this specification and the claims which follow, unless the context requires otherwise, the word "comprise", and variations such as "comprises" or "comprising", will be understood to imply the inclusion of a stated integer or step or group of integers or steps but not the exclusion of any other integer or step or group of integers or steps.

The reference in this specification to any prior publication (or information derived from it), or to any matter which is known, is not, and should not be taken as, an acknowledgement or admission or any form of suggestion that that prior publication (or information derived from it) or known matter forms part of the common general knowledge in the field of endeavour to which this specification relates.

2005216184 23 Jun 2008

CLAIMS

What is claimed is:

1. A portable x-ray device, comprising:
5 a housing with a first portion that contains an x-ray source that is powered by an integrated power system and the housing also contains an internal power source; wherein the x-ray device has a high current load sufficient for radiographic imaging.
2. The device of claim 1, wherein the integrated power system comprises a
10 plurality of low voltage power supplies.
3. The device of claim 1, wherein each power supply provides a power ranging from about 20 to about 50 kV.
- 15 4. The device of claim 2, wherein the power system provides a continuous high voltage DC power.
5. The device of claim 1, further comprising a display for a radiographic image that is integrated into the housing.
20
6. The device of claim 1, wherein the x-ray source is shielded with a low-density insulating material.
7. The device in claim 6, wherein the shielding further comprises a high-Z
25 substance.
8. A handheld x-ray device, comprising:

2005216184 23 Jun 2008

a housing with a first portion that contains an x-ray source shielded with a low-density insulating material and that is powered by an integrated power system; and

the housing also has a second portion that contains an internal power source, the second portion being removably attached to the first portion so that when the second
5 portion is removed from the first portion, no power is generated for the x-ray source; wherein the x-ray device has a high current load for radiographic imaging.

9. The device of claim 8, wherein the power system comprises a plurality of low voltage power supplies with each power supply providing a power ranging from about
10 20 to about 50 kV.

10. The device of claim 6 or 8, wherein the low-density insulating material comprises silicone or epoxy.

15 11. The device in claim 7 or 10, wherein the shielding further comprises a high-Z substance comprising W, Ta, Bi, Ba, or combinations thereof.

12. A system for x-ray analysis, the system containing a portable x-ray device with a housing containing an x-ray source that is powered by an integrated power system
20 which includes a plurality of power supplies with each power supply providing a power ranging from about 20kV to about 50kV and the integrated power system provides a high current load sufficient for radiographic imaging wherein the housing also contains an internal power source.

25 13. The system of claim 12, wherein x-ray ray source is contained in a first portion of the housing and the internal power source is contained in a second portion that is removably attached to the first portion so that when the second portion is removed from the first portion, no power is generated for the x-ray source.

2005216184 23 Jun 2008

14. A method for making a portable x-ray device with a high current load, the method comprising:

providing an x-ray source in a first portion of a housing;

5 providing an integrated power system in the first portion of the housing and connecting it to the x-ray source;

providing an internal power source in a removable, second portion of the housing;

and

connecting the second portion to the first portion.

10

15. The method of claim 14, including:

providing the power system with a plurality of low voltage power supplies with each power supply providing a power ranging from about 20 to about 50 kV; and

providing the x-ray source with a shielding comprising a low-density insulating

15 material containing a high-Z substance.

16. A method for analysis, comprising:

providing a material to be analyzed;

20 providing a portable x-ray device with a high current load, the device having a housing that contains an x-ray source that is powered by an integrated power system and the housing also contains an internal power source; and

actuating the x-ray source so that an x-ray impinges on the material.

17. A method for dental imaging, comprising:

25 providing a tooth of a patient to be analyzed;

providing a portable x-ray device with a high current load for radiographic imaging, the device having a housing that contains an x-ray source that is powered by an integrated power system and the housing also contains an internal power source; and

2005216184 23 Jun 2008

actuating the x-ray source so that x-rays impinge on that tooth.

18. The method of claim 16 or 17, including:

- 5 providing the power system with a plurality of low voltage power supplies with
- each power supply providing a power ranging from about 20 to about 50 kV; and
- providing the x-ray source with a shielding comprising a low-density insulating material containing a high-Z substance.

19. A portable x-ray device, comprising:

- 10 a housing having a first portion that contains an x-ray source that is powered by an integrated power system which includes a plurality of power supplies with each power supply providing a power ranging from about 20kV to about 50kV and the power system provides a current sufficient for radiographic imaging;

- the housing also having a second portion that contains an internal power source and
- 15 the second portion is removably attached to the first portion so that when the second portion is removed from the first portion, no power is generated for the x-ray source; and
- a display integrated into the first portion of the housing to display a radiographic image.

- 20 20. The device of claim 12 or 19, wherein the x-ray source contains a shielding comprising a low-density insulating material containing a high-Z substance.

- 21. A portable x-ray device, a handheld x-ray device, a system for x-ray analysis, a method for making a portable x-ray device with a high current load, a method
- 25 for analysis, or a method for dental imaging, substantially as herein before described with reference to the accompanying drawings.

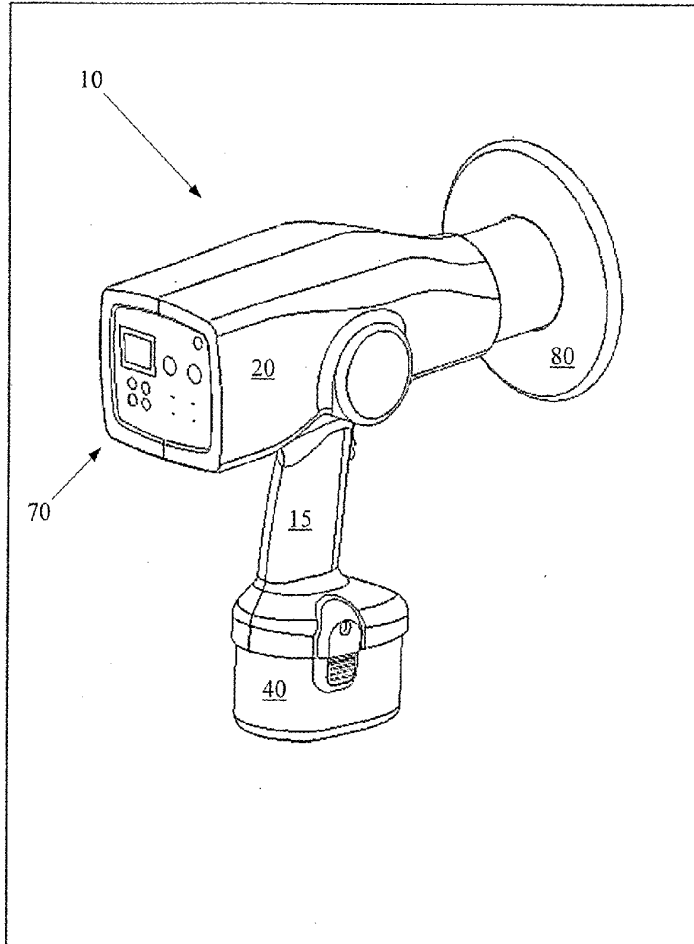

FIGURE 1

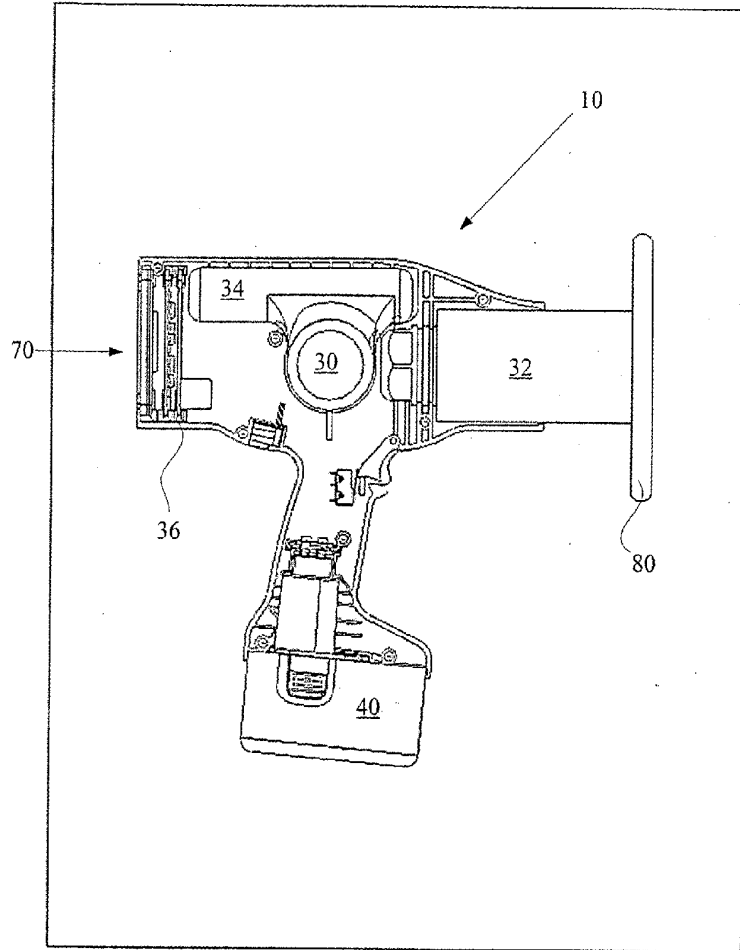

FIGURE 2

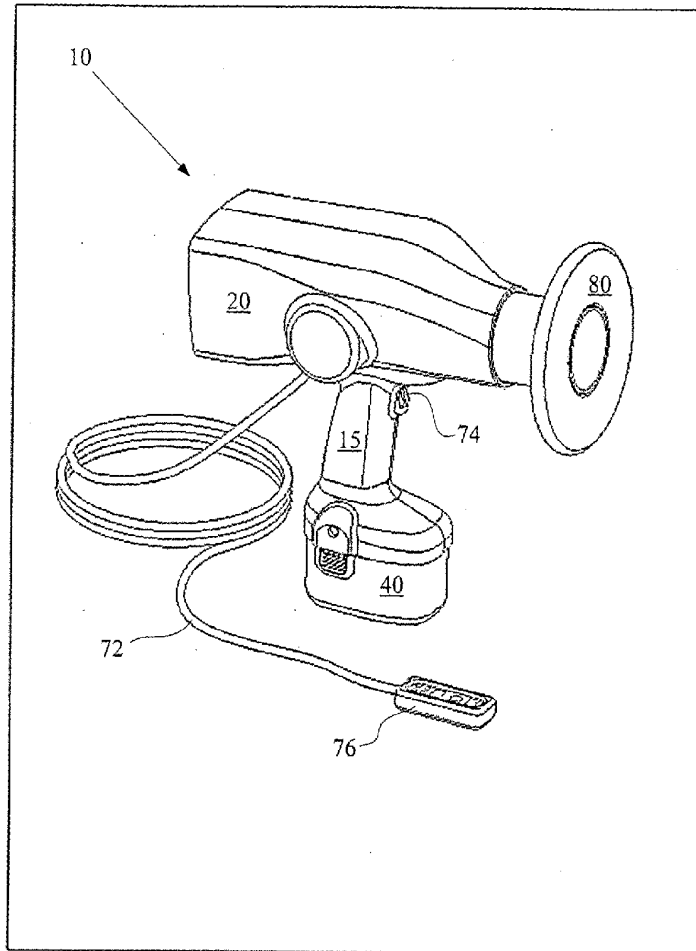

FIGURE 3

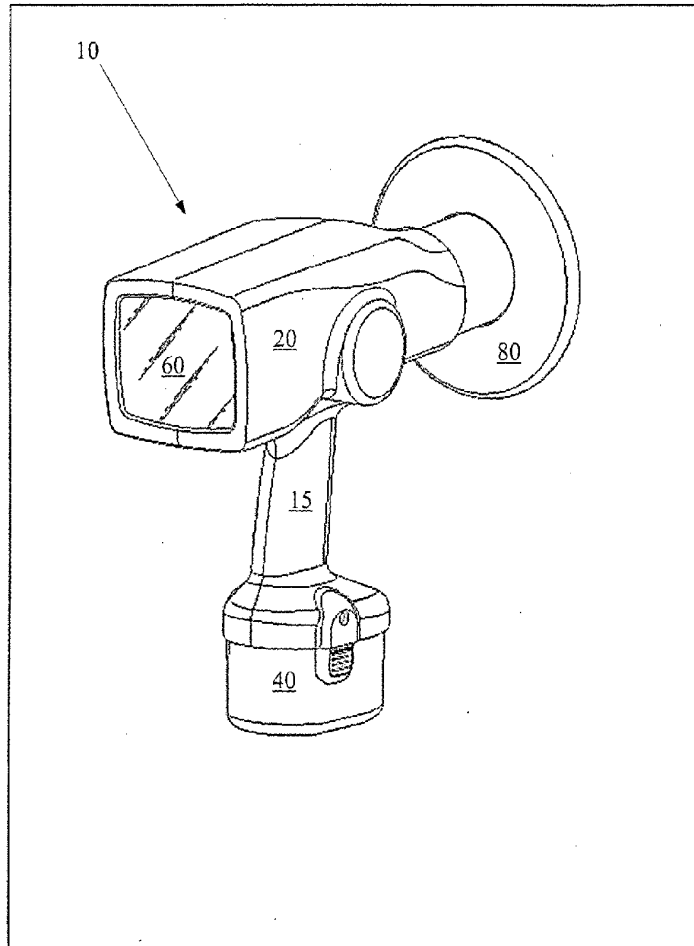

FIGURE 4

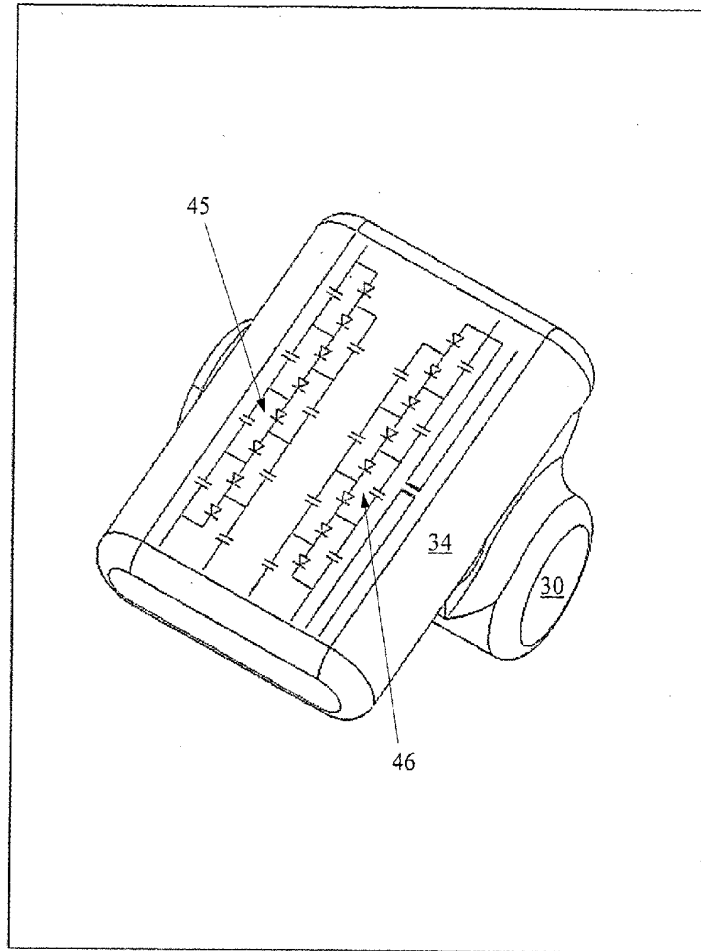

FIGURE 5

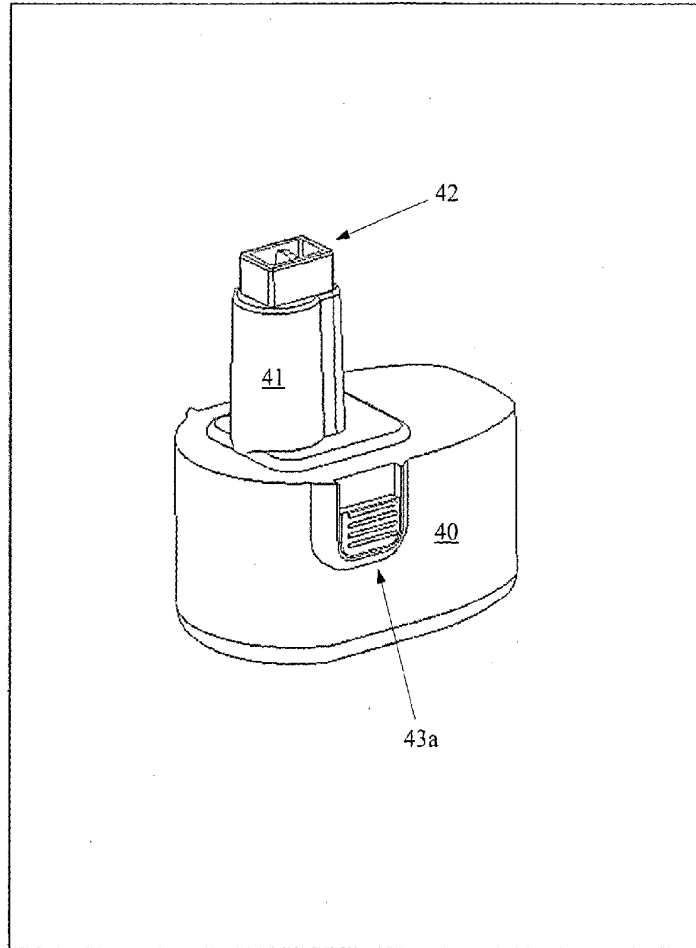

FIGURE 6

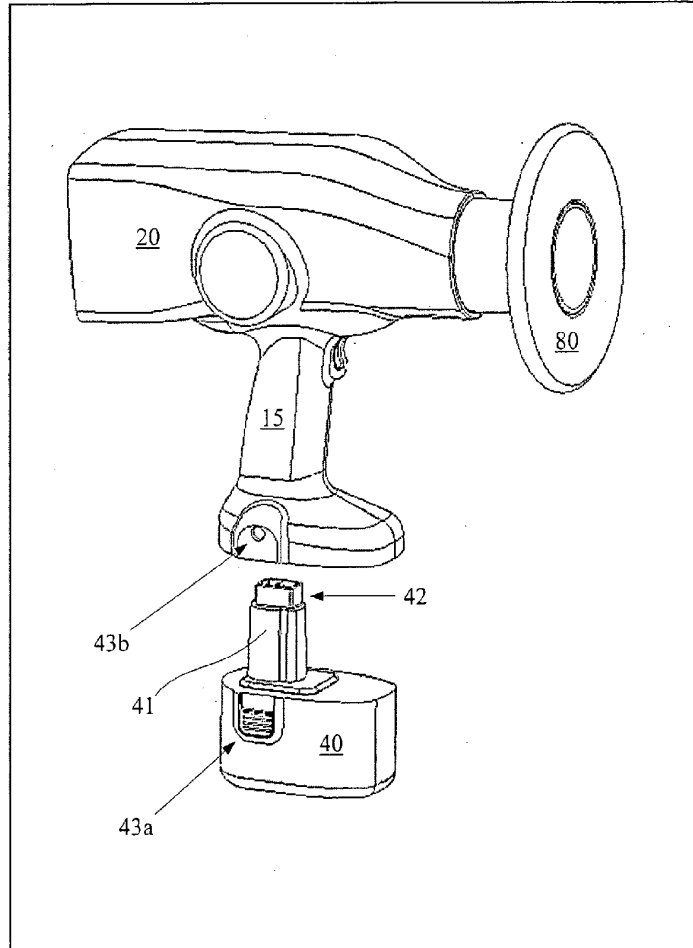

FIGURE 7

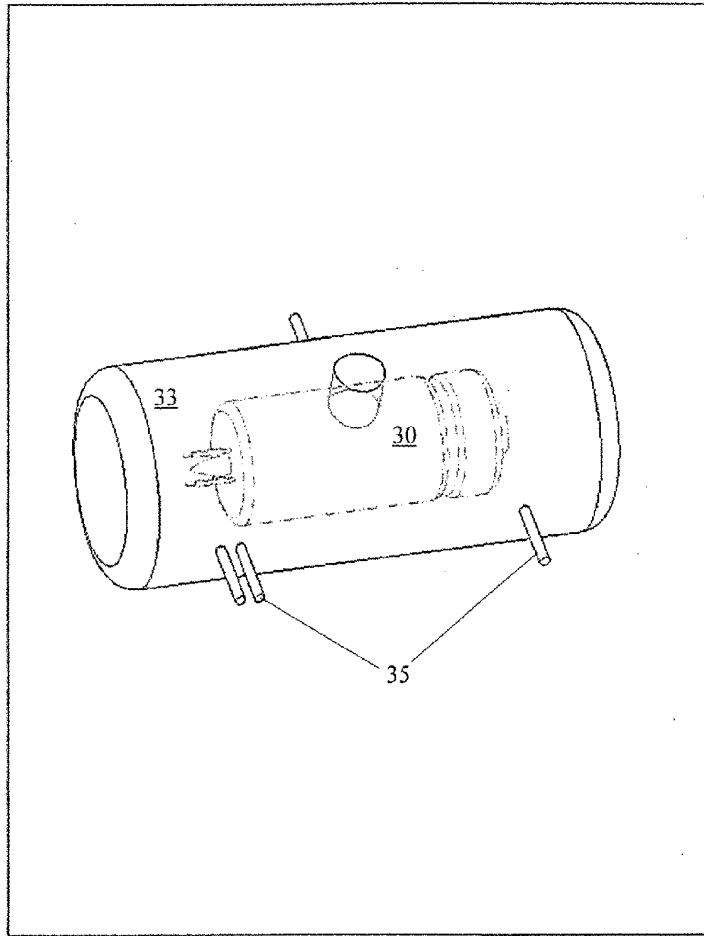

FIGURE 8

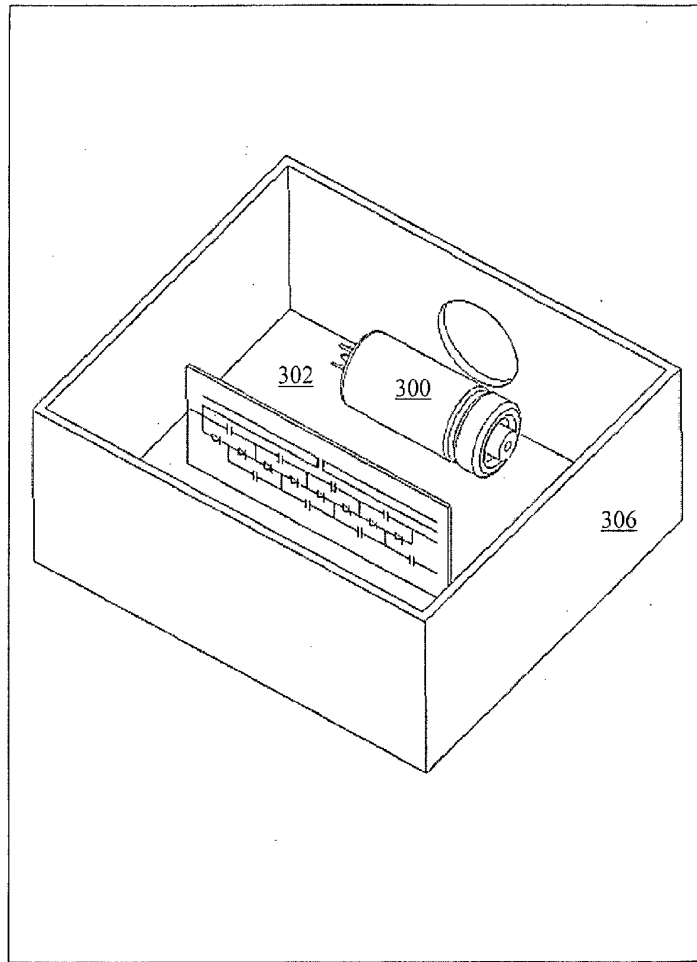

FIGURE 9
(PRIOR ART)