

(19) World Intellectual Property Organization
International Bureau



(43) International Publication Date
3 May 2001 (03.05.2001)

PCT

(10) International Publication Number
WO 01/31081 A1

- (51) International Patent Classification⁷: C23C 16/00
- (21) International Application Number: PCT/US00/29099
- (22) International Filing Date: 20 October 2000 (20.10.2000)
- (25) Filing Language: English
- (26) Publication Language: English
- (30) Priority Data:
60/161,094 22 October 1999 (22.10.1999) US
- (71) Applicant (for all designated States except US): **KURT J. LESKER COMPANY** [US/US]; 1515 Worthington Avenue, Clairton, PA 15025 (US).
- (72) Inventor; and
- (75) Inventor/Applicant (for US only): **SMITH, Gary, L.** [US/US]; 101 Royal Place, McMurray, PA 15317 (US).
- (74) Agents: **BYRNE, Richard, L.** et al.; Webb Ziesenheim Logsdon Orkin & Hanson, P.C., 700 Koppers Building, 436 Seventh Avenue, Pittsburgh, PA 15219-1818 (US).
- (81) Designated States (national): AE, AG, AL, AM, AT, AT (utility model), AU, AZ, BA, BB, BG, BR, BY, BZ, CA, CH, CN, CR, CU, CZ, CZ (utility model), DE, DE (utility model), DK, DK (utility model), DM, DZ, EE, EE (utility model), ES, FI, FI (utility model), GB, GD, GE, GH, GM, HR, HU, ID, IL, IN, IS, JP, KE, KG, KP, KR, KZ, LC, LK, LR, LS, LT, LU, LV, MA, MD, MG, MK, MN, MW, MX, MZ, NO, NZ, PL, PT, RO, RU, SD, SE, SG, SI, SK, SK (utility model), SL, TJ, TM, TR, TT, TZ, UA, UG, US, UZ, VN, YU, ZA, ZW.
- (84) Designated States (regional): ARIPO patent (GH, GM, KE, LS, MW, MZ, SD, SL, SZ, TZ, UG, ZW), Eurasian patent (AM, AZ, BY, KG, KZ, MD, RU, TJ, TM), European patent (AT, BE, CH, CY, DE, DK, ES, FI, FR, GB, GR, IE, IT, LU, MC, NL, PT, SE), OAPI patent (BF, BJ, CF, CG, CI, CM, GA, GN, GW, ML, MR, NE, SN, TD, TG).
- Published:
— With international search report.
- For two-letter codes and other abbreviations, refer to the "Guidance Notes on Codes and Abbreviations" appearing at the beginning of each regular issue of the PCT Gazette.

(54) Title: METHOD AND APPARATUS FOR COATING A SUBSTRATE IN A VACUUM

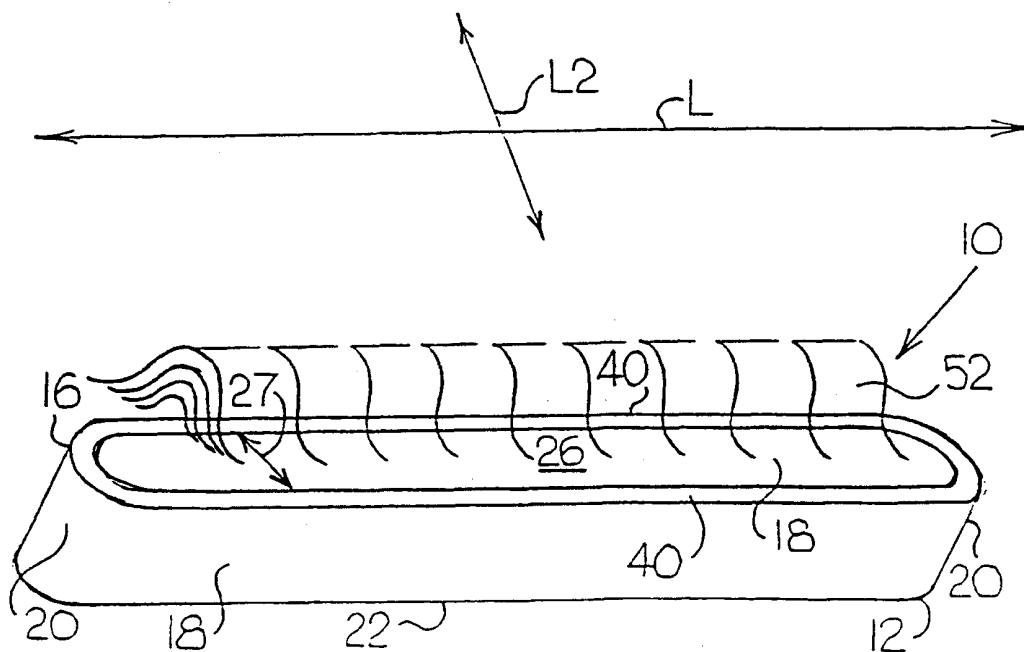

(57) Abstract: A method and apparatus for coating a substrate with a deposition material in a vacuum wherein a material source having a substantially longitudinal deposition emission component is used to create a substantially longitudinal material deposition emission plume which coats a surface of the substrate without increasing the throw distance between the substrate and the material source.



WO 01/31081 A1

METHOD AND APPARATUS FOR COATING A SUBSTRATE IN A VACUUM

BACKGROUND OF THE INVENTION1. Field of the Invention

5 The present invention relates to material coating and, more particularly, to a method and apparatus for coating a substrate with a deposition material in a vacuum.

2. Brief Description of the Prior Art

10 Coating a substrate with a deposition material typically involves vaporizing the deposition material in a vacuum such that the vaporized deposition material condenses onto a substrate that is at a lower temperature than the temperature of the vaporized deposition material.

15 In the production of organic-based devices, a thin, flat, film-like substrate is coated with a chemical coating, usually organic based, on at least one side of the substrate. The substrate material may be glass or a plastic/polymeric material and though typically planar in configuration, may also consist of a curved or non-planar surface. The size of the substrate being coated is
20 generally limited to a few square inches due to technical capability limitations of current material sources.

 During fabrication of most organic-based devices, such as organic-based LED displays, organic-based lasers,
25 organic-based photo-voltaic panels, and organic-based integrated circuits, chemicals or deposition materials are typically applied to the substrate in a vacuum, using a point source crucible A, shown in Fig. 1, or a modified point source crucible. When the chemicals are heated, the
30 chemicals vaporize and radiate away from the point source crucible A, through an exit aperture B, in a generally cosine-shaped emission plume C. A substrate D is then typically held in a fixed position or rotated within the emission plume C with a planar side E of the substrate D
35 facing the point source crucible A. A certain amount of

vaporized chemicals deposits on the planar side E of the substrate D, forming a film coating.

In some applications, modified point sources are used to produce a gaussian (non-uniform) flux distribution.

5 Examples of modified point sources include R.D. Mathis-type boats, Knudsen cells, or induction furnace sources. A general drawback of point or modified point source crucibles, however, is their design. First, the ability to control evaporation rates of chemicals involves sensitive,
10 precise control over material temperatures and temperature gradients with low heat capacities and poor thermal conductivity. Point sources/gaussian material sources typically use radiant reflectors, insulation, and baffling to create good evaporation rates for metals and salts at
15 higher temperatures of 1,000-2,000°C. However, these material sources are inappropriate for evaporating organic-based chemicals at lower temperatures of 100-600°C. Excessive heat applied to many organic-based chemicals will spit the chemicals out of the material sources, destroying
20 any film being grown on the substrate and requiring the vacuum system to be taken out of service in order to be cleaned and reloaded. Another problem is that the vaporized chemicals frequently condense into the exit apertures of the crucibles of point or modified point
25 sources. The condensation of the vaporized chemicals begins to alter or occlude the exit aperture, causing chemicals to fall back into the crucible's heated interior, and spit onto the substrate. This spitting ruins the homogenous distribution of the chemical film, because films having
30 spit defects exhibit higher surface roughness values and may exhibit pinhole defects entirely through the deposited layers. The source aperture condensation also degrades the uniformity of the deposited film by altering the flux emission distribution.

Another disadvantage of both point and modified point source crucibles is that no axis of flux uniformity can be found. Point source and modified point source crucibles produce relatively uniform films only when flux angles are kept small. As shown in Fig. 2, flux angles α , β , and γ are measured from a normal axis N extending from the exit aperture of the point source crucible to lines L1, L2, and L3 representing the edge of the cosine-shaped plume C shown in Fig. 1. The only way to keep the flux angle small, such as the angle α shown in Fig. 2, is to greatly increase the separation distance, or throw distance, between the point source crucible A and the planar side E of a substrate, such as those substrates referred to by reference numerals D1, D2, and D3. For example, substrate D2 would need to be moved to the position of substrate D3 to be fully coated, while keeping the flux angle α constant. Such a move would increase the throw distance from TD2 to TD3. Similarly, if substrate D3 is moved to the position of substrate D1, i.e., from TD3 to TD1, then only a small portion of substrate D3 would be coated, and the deposited coating would be much less uniform. Film uniformity is a very important characteristic of organic layers utilized for photonic and electronic applications as the fabricated devices will not operate properly, if at all, if the organic-based films are not maintained at a 95 percent or higher level of uniformity.

Throw distances can be predicted in order to achieve a uniform film of 95 percent or higher. If this uniformity requirement is applied to a 6-inch square substrate, for example, then a throw distance of approximately 2 1/2 feet may be required. By comparison, a 24-inch square substrate would require a throw distance of 9 1/2 feet. This increasing throw distance destroys the ability to develop a productive process, because the rate

of film growth is inversely proportional to the square of the distance between the crucible and the substrate.

Film growth rates of organic-based materials are typically expressed in single Angstroms per second. For example, a throw distance of one foot or less would be desirable for coating a 12-inch substrate with a 95 percent uniform film coating 1000 Angstroms thick. At the one-foot throw distance, a typical chemical deposition rate would be 18 Angstroms per second, which equates to a coating time of approximately fifty-five seconds. Conversely, at a throw distance of 9 1/2 feet, the typical deposition rate is 2 Angstroms per second, resulting in a 1 1/2-hour deposition time.

In addition to increasing film growth rates, increases in throw distance significantly increase production costs. First, vacuum chambers must be large enough to accommodate the increased throw distances, requiring larger vacuum deposition chambers as well as more powerful vacuum pumps. Second, there is a substantial waste of expensive chemicals, since an increase in throw distance decreases deposition efficiency. Third, because the vaporized organic material that does not reach the substrate is deposited on an interior wall of the vacuum chamber, the vacuum chamber must be removed from productive service and cleaned more frequently. Cleaning is expensive because some chemicals, such as those used to produce organic liquid electronic displays, are toxic as well as expensive. Costs are further exaggerated because point or modified point source crucibles only hold between 1 and 10 cubic centimeters of chemicals. Therefore, only a few substrates can be coated before the vacuum chamber must be brought to atmosphere, the vacuum chamber cleaned, the crucibles refilled, and the vacuum chamber re-evacuated.

It is therefore an object of the present invention to produce a method and apparatus for coating a

substrate in a vacuum that allows larger substrates to be coated without increasing throw distances as the width of a substrate increases, allowing more deposition material to be deposited on the substrate during coating, reducing
5 loading downtime, and reducing cleaning time.

SUMMARY OF THE INVENTION

In order to help solve the problems associated with the prior art, the present invention generally includes a vacuum deposition system for coating a substrate
10 with a deposition material. The vacuum deposition system includes a vacuum chamber and a material source positioned inside the vacuum chamber. The material source has a body which extends along a longitudinal axis, a substantial longitudinal emission component, and defines an interior
15 cavity and an exit aperture fluidly connected to the interior cavity. A heat source is positioned adjacent to the body of the material source.

A substrate to be coated, having a width measured parallel to the longitudinal axis of the body, may be
20 positioned inside the vacuum chamber, wherein a throw distance, measured between one side of the substrate and the exit aperture, remains constant as the width of the substrate increases. Preferably, the substantial longitudinal component of the body of the material source
25 is equal to the width of the substrate or less than the width of the substrate.

A deposition material is loaded into the interior cavity of the body of the material source. The deposition material is selected from the group including an organic-
30 based chemical and an organic-based compound. The deposition material is heated by the heat source and emitted through the exit aperture along the substantial longitudinal emission component of the body of the material source.

The material source may have a body in the shape of an open trough having two longitudinally extending sidewalls and a pair of endwalls, wherein the longitudinally extending sidewalls and the endwalls define the interior cavity of the body. The body of the material source may further define an upper end positioned adjacent to the exit aperture and a base, with the heat source being a heating coil having a greater number of heating elements positioned at the upper end of the body than at the base of the body. The exit aperture may extend continuously along the substantial longitudinal emission component of the body and ribs positioned in the internal cavity defined by the body of the material source.

The material source may also have a first conduit defining an internal cavity and a first exit aperture fluidly connected to the internal cavity, wherein the body is a second conduit received in the internal cavity of a first conduit. The first exit aperture defined by the first conduit may be aligned with the exit aperture defined by the second conduit or, the first exit aperture defined by the first conduit may be aligned in a non-coincident configuration with the exit aperture defined by the second conduit. Regardless of body type, a process control apparatus may be connected to the body of the material source.

One method of coating a substrate using a material source and a vacuum chamber includes the steps of:

- a. positioning the material source in the vacuum chamber, the material source having a body which extends along a longitudinal axis, has a substantial longitudinal emission component, and defines an interior cavity and an exit aperture fluidly connected to the interior cavity;
- b. positioning a substrate in the vacuum chamber, opposite the exit aperture defined by the body of the material source;

c. loading a deposition material in the interior cavity defined by the body of the material source;

d. evacuating the vacuum chamber to create a vacuum;

5 e. heating the deposition material in the internal cavity of the body of the material source;

f. emitting vaporized deposition material along the substantially longitudinal component of the body; and

10 g. moving the substrate through the vaporized deposition material.

The substrate may be moved through the vaporized deposition material at a constant velocity. When substrate coating is complete, the substrates can move to another process or the vacuum chamber can be opened, the coated
15 substrates removed, new substrates added, the vacuum chamber re-evacuated, and the above process steps repeated.

One type of material source for use in vacuum deposition of a deposition material onto a surface of a substrate includes two bodies, such as a point source
20 crucible, a modified point source crucible, or a combination, with each of the two bodies defining an interior cavity and at least one exit aperture fluidly connected to the interior cavity and a heating element positioned adjacent to each of the two bodies, wherein the
25 two bodies are aligned along a common longitudinal axis to form a substantial longitudinal emission component. A process control apparatus may be connected to one of the two bodies of the material source, and the interior cavities of the two bodies are configured to receive
30 deposition material selected from the group including an organic-based chemical and an organic-based chemical compound.

Another type of material source for use in vacuum deposition of a deposition material onto a surface of a
35 substrate includes a body which extends along a

longitudinal axis, has a substantial longitudinal emission component, and defines an interior cavity and at least one exit aperture fluidly connected to the interior cavity and a heat source positioned adjacent to the body of the material source. The exit aperture may extend continuously along the substantial longitudinal emission component of the body and ribs may be positioned in the internal cavity defined by the body of the material source. The material source may have a body in the shape of an open trough having two longitudinally extending sidewalls and a pair of endwalls, wherein the longitudinally extending sidewalls and the endwalls define the interior cavity of the body.

The material source may also include a first conduit defining an internal cavity and a first exit aperture fluidly connected to the internal cavity, wherein the body is a second conduit received in the internal cavity of a first conduit. The heat source is positioned adjacent to the first conduit or the second conduit, the heat source including a first layer of heat conductive electrical insulation, a second layer of conductive material, and a third layer of heat conductive electrical insulation. The first exit aperture defined by the first conduit may be aligned with the exit aperture defined by the second conduit or the first exit aperture defined by the first conduit may be aligned in a non-coincident configuration with the exit aperture defined by the second conduit.

These and other advantages of the present invention will be clarified in the Detailed Description of the Preferred Embodiments taken together with the attached drawings in which like reference numerals represent like elements throughout.

BRIEF DESCRIPTION OF THE DRAWINGS

Fig. 1 is a side view of a prior art single point source crucible;

Fig. 2 is a side view of a prior art single point source crucible shown in Fig. 1 with increasingly larger substrates positioned adjacent to the crucible;

Fig. 3 is a perspective cross-sectional view of a material source according to one embodiment of the present invention;

Fig. 4 is a cross-sectional end view of the material source shown in Fig. 3;

Fig. 5 is a cross-sectional side view of the material source shown in Figs. 3 and 4;

Fig. 6 is a top perspective view of an emission plume axially extending along a substantially longitudinal component of the material source shown in Figs. 3-5;

Fig. 7 is a top view of two material sources shown in Fig. 5 positioned inside a vacuum chamber;

Fig. 8 is a side view of four material sources shown in Figs. 5-7 positioned at offset angles inside a vacuum chamber;

Fig. 9 is a top view of a plurality of material sources according to a second embodiment of the present invention;

Fig. 10 is a perspective view of a material source according to a third embodiment of the present invention;

Fig. 11 is a perspective view of a first conduit with a resistive heating element positioned adjacent to an exterior surface of the first conduit;

Fig. 12 is a cross-sectional end view of the first conduit shown in Figs. 10-11 and a second conduit positioned inside the first conduit; and

Fig. 13 is a cross-sectional side view of the third embodiment material source shown in Fig. 10.

DETAILED DESCRIPTION OF THE PREFERRED EMBODIMENTS

Figs. 3-8 show one embodiment of material source 10 in accordance with the present invention. Fig. 3 shows

a trough crucible 12 type of material source 10 for evaporating deposition materials 14, such as organic chemicals or organic compounds, or other suitable materials. The trough crucible 12 generally includes an elongated, open-topped body 16 extending about a longitudinal axis L. As shown in Figs. 3 and 6, the body 16 preferably includes opposing longitudinal sidewalls 18, opposing endwalls 20, and a base 22 formed together as a unitary structure. The sidewalls 18 and endwalls 20 preferably have the same width W, as shown in Fig. 3, but the sidewalls 18 preferably have a longer sidewall length SL than the length EL of the endwalls 20, as shown in Fig. 7. Because the sidewalls 18 extend over a longer length SL than the length EL of the endwalls 20, the body 16 has a substantial longitudinal emission component, approximately equal to the sidewall length SL and a smaller lateral emission component, which is approximately equal to the length EL of the endwalls 20. Moreover, the sidewalls 18 of the trough crucible 12 are preferably longer than a substrate 24 to be coated, as shown in Fig. 7, such as the use of a 15-inch length sidewall 18 for coating a 12-inch square substrate 24.

Referring to Figs. 3-4, the sidewalls 18, the endwalls 20, and the base 22 of the body 16 define an internal cavity 26 and an exit aperture 27, with the base 22 of the body 16 further defining ribs 28, shown in Figs. 5 and 7, positioned adjacent to the internal cavity 26, adjacent to a first surface 30 of the base 22, and preferably extending between the sidewalls 18. The ribs 28 may be integrally formed into the body 16, such as by machining, in order to further assist in the uniform loading of deposition materials 14 into the trough crucible 12, as well as further collimating the vertical flux of the trough crucible 12. As shown in Figs. 5 and 6, the ribs 28 deposition materials 14, such as organic material, in such

a manner that the entire trough crucible 12 may be slightly rotated about axis L2, even when loaded with a preferred load of approximately 50 cubic centimeters to 100 cubic centimeters of deposition materials 14. The body 16 and
5 ribs 28 are formed from a heat conducting material, preferably a material that produces uniform heat distribution. Ceramic is preferred, but metal or other suitable materials are also acceptable. Various coatings may be applied to the body 16 in order to enhance
10 durability and performance of the body 16.

As shown in Fig. 8, the trough crucible 12 can also be rotated slightly about the longitudinal axis L. This allows multiple trough crucibles 12, each loaded with different deposition materials 14 such as organic based
15 chemicals, to emit vaporized chemicals along a common deposition axis 32. Different vaporous deposition materials 14 can mix in a mixing zone 34 and be more evenly distributed onto the substrate 24. An aperture 36 may be used to target deposition materials 14 in the mixing zone
20 34 and restrict the passage of deposition materials 14 to the substrate 24.

As shown in Figs. 3-4 and 7-8, heating elements 38 are positioned adjacent the body 16, preferably adjacent the outer surface of the sidewalls 18, with a higher
25 concentration of heating elements 38 positioned adjacent an upper edge 40 of each sidewall 18 adjacent to the exit aperture 27. The higher concentration of heating elements 38 adjacent the upper edge 40 of each sidewall 18 helps prevent re-crystallization of the vaporous deposition
30 materials 14. Similarly, by introducing a vertical temperature gradient with a lower temperature at the base 22 of the trough crucible 12, spitting is reduced from eruptions originating near the base 22. The heating elements 38 are preferably surface mounted, but may also be
35 embedded or otherwise positioned adjacent to the sidewalls

18. Alternatively, the heat may be provided by heating lamps (not shown), heating elements 38 positioned at a distance from the sidewalls 18 of the trough crucible 12, or induction.

5 As shown in Fig. 3, power supply leads 42 are connected to the heating elements 38. A thermocouple temperature sensing probe 44 is positioned adjacent to the trough crucible 12, preferably adjacent to the base 22. The thermocouple temperature sensing probe 44 is connected
10 to sensing equipment and other process control apparatus 45 that regulate the coating process.

 With appropriate power control, the temperature of the deposition materials 14 can be ramped to preset values. With appropriate deposition materials 14 emission
15 monitoring, such as a quartz crystal motor head, the deposition materials 14 may be throttled to preset rates of deposition or emission. With more intelligent power controllers and crystal sensors, pre-programmed thermal routines may be set up in order to quickly degas and vacuum
20 prepare fresh deposition materials 14 loads for quick turnaround of the trough crucible 12 type of material sources 10.

 In a second embodiment of the present invention, shown in Fig. 9, the material source 10' includes a
25 plurality of point source crucibles 46 arranged along a longitudinal axis L' in a linear array inside a vacuum chamber 48 to create a substantially longitudinal emission component which is approximately equal to the total length LA of the linear array. Like the first embodiment material
30 source 10, the second embodiment provides a material source 10' which has a substantial longitudinal emission component which is larger than a lateral component of the material source. Each point source crucible 46 has a body 16' forming an exit aperture 27', a heating element 38', power
35 supply leads 42', and a thermocouple temperature sensing

probe 44'. The linear array pattern can roughly simulate the linear output of the trough crucible 12 shown in Figs. 3-8 and is therefore useful for coating substrates 24 having a width W2 of more than a few inches. However, the benefits are tempered by the known deficiencies, such as spitting and multiple requirements for separate power supplies, temperature displays, crystal heads, and feedback and control loops.

A third embodiment of a material source 10'' in accordance with the present invention is generally shown in Figs. 10-13. As shown in Fig. 10, the third embodiment material source 10'' includes a first conduit 56 or other substantially hollow structure partially covered in an optional heat shield 94. The first conduit 56 has two opposing end sections 58, 60, defining at least one exit aperture 27''. The first conduit 56 is supported by posts 62 or similar support fixtures or hardware attached to a base 64. As shown in Fig. 11, a resistive heater element 74, such as a grid pattern, is positioned adjacent to an exterior surface 76 of the first conduit 56.

As shown in Fig. 12, a second conduit 66 or other structure defining an internal cavity fluidly connected to an exit aperture is received in the internal cavity 68 defined by the first conduit 56. The second conduit 66, which is configured to receive deposition material 14, such as organic-based or other chemicals, generally defines a second internal cavity 70 fluidly connected to a second exit aperture 27'''. The first conduit 56 and the second conduit 66 are both made from ceramic or other suitable material. A center axis C1 of the first conduit 56 may be positioned coincident or eccentric with respect to a center axis C2 of the second conduit 66. The second exit aperture 27''' may be aligned with the exit aperture 27'' defined by the first conduit 56 or, alternatively, the exit apertures 27'', 27''' may be aligned in a non-coincident aligned

configuration with the exit apertures 27'', 27''' defined by the first and second conduits 56, 66 not presenting a line of sight path SP between the deposition materials 14 received by the second conduit 66 and the substrate 24. To
5 aid the alignment of the first conduit 56 and the second conduit 66, optional support rods 72 made from quartz or other suitable material may be extended between the opposing end sections 58, 60 of the first conduit 56. Additional second conduits 66 may also be housed within the
10 first conduit 56 to allow for the emission of multiple chemicals.

Fig. 13 shows the third embodiment of the present invention in more detail, with the grid type of resistive heater element 74 replaced with a resistive heater element
15 74'. The resistive heater element 74' includes a first layer 78 of heat conductive electrical insulation, such as alumina, followed by a second resistive layer 80 of NiCr or other suitable resistive conductive materials, followed by a third layer 78' of heat conductive electrical insulation.
20 As previously noted above, heat shields 94 and insulating buttons 96 can be positioned adjacent to the third layer of heat conductive electrical insulation.

With continuing reference to Fig. 13, the first and second conduits 56, 66 are nested together. One of the
25 opposing end sections 58 of the first conduit 56 is removeably attached to an opposing end section 84 of the second conduit 66, with the end section 84 of the second conduit removeably attached to the second conduit 66. A rod 88, surrounded by a bushing 90, extends through the end
30 section 58 of the first conduit 56 and the corresponding opposing end section 84 of the second conduit 66. A second rod 88, also surrounded by a bushing 90', extends through the other opposing end section 60 of the first conduit 56 and the other corresponding opposing end section 86 of the
35 second conduit 66. The second rod 88' is supported by a

notched support arm 92 connected to the base 64. The heat shields 92 and insulating buttons 94 used to position the shields 92 were discussed earlier.

At least one electrode 98 extends through the
5 base 64 of the third embodiment material source 10'',
electrically insulated from the base 64 by an insulating
material 100, such as ceramic or other suitable material.
The electrode 98 is connected to the resistive heating
element 74'' to power leads 42. Electrical contact clamps
10 102 removeably attach the first conduit 56 to the electrode
98.

A material source according to any of the
embodiments of the present invention can be used to coat a
substrate 24, with the trough crucible 12 or hollow conduit
15 56'' material source 10, 10'' being preferred. For the
sake of clarity, only the first embodiment will be
described unless otherwise indicated.

In one method of operation, as shown in Figs. 7-
8, the coating operation begins by positioning the
20 deposition materials 14 in the material source 10 and then
positioning one or more material sources 10 and one or more
substrates 24 into the vacuum chamber 48. The material
sources 10 should be positioned parallel to one another,
with the substrate axis 50 of each substrate 24 positioned
25 approximately perpendicular to the longitudinal axis L of
the parallel material sources 10.

An additional optional step is degassing the
material source 10, the vacuum chamber 48, and a desired
amount of deposition materials 14. For example, the
30 deposition materials 14 load for the trough crucible 12 is
generally 70 cubic centimeters to 100 cubic centimeters,
but may be increased or decreased depending on the size of
the material source 10.

The next step is evacuating the vacuum chamber 48
35 to the desired vacuum pressure, preferably less than $1 \cdot 10^{(-3)}$

Torr, and normally less than $9 \cdot 10^{(-6)}$ Torr, or other suitable vacuum pressure. Once a suitable vacuum is established, the next step is heating the deposition materials 14 loaded in one or more of the material sources 10 until the deposition materials 14 vaporize and radiate a plume 52 of vaporized deposition materials 14. Once the vaporization has begun, the next step is moving the substrate 24 through the linear-shaped plume 52 at a constant velocity v , as shown in Figs. 7 and 8. Film deposition characteristics are generally a growth rate of ≥ 10 Angstroms per second with film uniformity of >95 percent. The substrates 24 can be moved by any suitable movement device, with an overhead conveyer (not shown) being preferred.

In operation of the third embodiment material source 10'' of the present invention, the deposition materials 14 are loaded into the second conduit 56 and are heated by radiative heat transfer from an interior surface 82 of the first conduit 56. The deposition materials 14 are vaporized and pass through the exit aperture or apertures 27'' defined by the second conduit 66, through the exit aperture 27''' or apertures defined by the first conduit 56, and then into the vacuum chamber 48. The exit aperture 27''' defined by the second conduit 66 may coincide with the exit aperture 27'', 27'' defined by the first and second conduits 56, 66 or may be in a non-coincident aligned configuration wherein the exit aperture 27''', 27'' of the first and second conduits 56, 66 do not present a line of sight SP between the deposition materials 14 and a substrate 24.

As shown in Figs. 7 and 8 but generally applicable to all of the embodiments, the linear design of the material source 10 helps to guarantee film uniformity out to the very edges 54 of the substrates 24 as the substrates 24 are passed through vaporous deposition

materials 14 plumes 52. However, if a trough crucible 12 or hollow conduit type of material source 10 is used, uniformity is best achieved by making the sidewalls 18 (or the conduit) longer in a longitudinal direction SL than a width W2 of substrate 24. This is due to the presence of reduced numbers of integrated gaussian flux emission angles available to bolster the emission from the endwalls 20 of the material source 10. The use of a variable exit aperture or hole dimensions may be used to offset this effect and produce a more uniform emission across the emission of the material source.

It should be apparent that the present invention allows large substrates 24 to be coated with deposition materials 14. This result is produced while generally reducing deposition materials 14 waste, exposure to potentially hazardous materials, the need for larger vacuum chambers 48, coating time, and operating costs. Since the present invention produces a vaporization plume that is generally linear over a much longer longitudinal component of the material source than the plume produced by a single point or a modified point source, non-uniformities observed with point sources and their associated cosine distribution plumes are eliminated or greatly reduced. Moreover, rather than increasing throw distances to several feet to achieve 95 percent uniformity levels, throw distances can be less than 1 foot, regardless of the size of the surface area of the side of the substrate to be coated.

Another feature of the present invention is that the majority of available gaussian emission angles can be used for deposition onto substrates passed over the material source or sources at a constant velocity. This results in a much greater percentage of chemicals deposited directly onto the substrate, rather than unnecessarily coating the internal surfaces of the vacuum chamber. This reduces downtime and greatly reduces organic chemical costs

for each substrate that is coated. A related benefit is that because the material source has a longer longitudinal component than a single point or a modified point source, more chemicals can be loaded into the material source, resulting in less downtime in commercial applications as the source may coat many more substrates between material source refilling periods.

Flexibility is also enhanced because the material source has standard feedthrough and power connections. Any vacuum system currently capable of accepting linear sputter material sources may be refitted with the material source in that position. Vacuum systems which are also fitted with 6-inch to 12-inch circular sputter sources may also accept a material source of similar or like size. Therefore, new vacuum systems need not be constructed in order to obtain the organic deposition capability of the present invention. The material source also lends itself to placement in banks or arrays within a limited chamber size. Several material sources may be readied with a vacuum system such that when one material source runs out of deposition materials, the next material source may be used. Moreover, material spitting is virtually eliminated from the trough crucible-type or the conduit-type of material sources, due to lower thermal gradients and crucible operating temperatures.

The invention has been described with reference to the preferred embodiments. Obvious modifications and alterations will occur to others upon reading and understanding the preceding detailed description. It is intended that the invention be construed as including all such modifications and alterations insofar as they come within the scope of the appended claims or the equivalents thereof.

I Claim:

1. A vacuum deposition system for coating a substrate with a deposition material comprising:

a vacuum chamber;

5 a material source positioned inside said vacuum chamber, said material source having a body which extends along a longitudinal axis, has a substantial longitudinal emission component, and defines an interior cavity and an exit aperture fluidly connected to said interior cavity;

10 and

a heat source positioned adjacent to said body of said material source.

2. The vacuum deposition system as claimed in claim 1 further comprising a substrate having a width measured parallel to the longitudinal axis of said body, wherein a throw distance, measured between one side of said substrate and said exit aperture, remains constant as said width of said substrate increases.

3. The vacuum deposition system as claimed in claim 1 further comprising a substrate having a width measured parallel to the longitudinal axis of said body wherein said substantial longitudinal component of said body of said material source is equal to said width of said substrate.

4. The vacuum deposition system as claimed in claim 1 further comprising a substrate having a width measured parallel to the longitudinal axis of said body wherein said substantial longitudinal component of said body of said material source is less than said width of said substrate.

5. The vacuum deposition system as claimed in claim 1 further comprising a deposition material loaded into said interior cavity of said body of said material source.

6. The vacuum deposition system as claimed in claim 5 wherein said deposition material is selected from the group consisting of an organic-based chemical and an organic-based compound.

7. The vacuum deposition system as claimed in claim 5 wherein said deposition material is heated by said heat source and emitted through said exit aperture along said substantial longitudinal emission component of said body of said material source.

8. The vacuum deposition system as claimed in claim 7 wherein said body of said material source further defines an upper end positioned adjacent to said exit aperture and a base and said heat source is a heating coil having a greater number of heating elements positioned at said upper end of said body than at said base of said body.

9. The vacuum deposition system as claimed in claim 1 further comprising a process control apparatus connected to said body of said material source.

10. The vacuum deposition system as claimed in claim 1 wherein said exit aperture extends continuously along said substantial longitudinal emission component of said body.

11. The vacuum deposition system as claimed in claim 1 further comprising ribs positioned in said internal cavity defined by said body of said material source.

12. The vacuum deposition system as claimed in claim 1 wherein said body is in the shape of an open trough having two longitudinally extending sidewalls and a pair of endwalls, wherein said longitudinally extending sidewalls and said endwalls define said interior cavity of said body.

13. The vacuum deposition system as claimed in claim 1 further comprising a first conduit defining an internal cavity and a first exit aperture fluidly connected to said in*ternal cavity, wherein said body is a second
5 conduit received in said internal cavity of a first conduit.

14. The vacuum deposition system as claimed in claim 13 wherein said first exit aperture defined by said first conduit is aligned with said exit aperture defined by said second conduit.

15. The vacuum deposition system as claimed in claim 13 wherein said first exit aperture defined by said first conduit is aligned in a non-coincident configuration with said exit aperture defined by said second conduit.

16. A method of coating a substrate using a material source and a vacuum chamber comprising the steps of:

positioning said material source in said vacuum
5 chamber, said material source having a body which extends
along a longitudinal axis, has a substantial longitudinal
emission component, and defines an interior cavity and an
exit aperture fluidly connected to said interior cavity;
positioning a substrate in said vacuum chamber,
10 opposite said exit aperture defined by said body of said
material source;
loading a deposition material in said interior
cavity defined by said body of said material source;
evacuating said vacuum chamber to create a
15 vacuum;
heating said deposition material in said internal
cavity of said body of said material source;
emitting vaporized deposition material along the
substantially longitudinal component of said body; and
20 moving said substrate through said vaporized
deposition material.

17. The method of coating a substrate using a
material source and a vacuum chamber as claimed in claim 16
wherein said substrate is moved through said vaporized
deposition material at a constant velocity.

18. A material source for use in vacuum
deposition of a deposition material onto a surface of a
substrate, said material source comprising:

two bodies each defining an interior cavity and
5 at least one exit aperture fluidly connected to said
interior cavity; and
a heating element positioned adjacent to each of
said two bodies;
wherein said two bodies are aligned along a
10 common longitudinal axis to form a substantial longitudinal
emission component.

19. The material source as claimed in claim 18 wherein one of said two bodies is a point source crucible.

20. The material source as claimed in claim 18 wherein one of said two bodies is a modified point source crucible.

21. The material source as claimed in claim 18 further comprising a process control apparatus connected to one of said two bodies of said material source.

22. The material source as claimed in claim 18 wherein said interior cavities of said two bodies are configured to receive deposition material selected from the group consisting of an organic-based chemical and an
5 organic-based chemical compound.

23. A material source for use in vacuum deposition of a deposition material onto a surface of a substrate, said material source comprising:

5 a body which extends along a longitudinal axis, has a substantial longitudinal emission component, an defines an interior cavity and at least one exit aperture fluidly connected to said interior cavity; and

a heat source positioned adjacent to said body of said material source.

24. The material source as claimed in claim 23 wherein said exit aperture extends continuously along said substantial longitudinal emission component of said body.

25. The material source as claimed in claim 23 further comprising ribs positioned in said internal cavity defined by said body of said material source.

26. The material source as claimed in claim 23 wherein said body is in the shape of an open trough having two longitudinally extending sidewalls and a pair of
5 endwalls, wherein said longitudinally extending sidewalls and said endwalls define said interior cavity of said body.

27. The material source as claimed in claim 23 further comprising a first conduit defining an internal cavity and a first exit aperture fluidly connected to said internal cavity, wherein said body is a second conduit
5 received in said internal cavity of a first conduit.

28. The material source as claimed in claim 27 wherein said heat source is positioned adjacent to said first conduit, said heat source comprising a first layer of heat conductive electrical insulation, a second layer of
5 conductive material, and a third layer of heat conductive electrical insulation.

29. The material source as claimed in claim 27 wherein said heat source is positioned adjacent to said second conduit, said heat source comprising a first layer of heat conductive electrical insulation, a second layer of
5 conductive material, and a third layer of heat conductive electrical insulation.

30. The material source as claimed in claim 23 wherein said first exit aperture defined by said first conduit is aligned with said exit aperture defined by said second conduit.

31. The material source as claimed in claim 23
wherein said first exit aperture defined by said first
conduit is aligned in a non-coincident configuration with
5 said exit aperture defined by said second conduit.

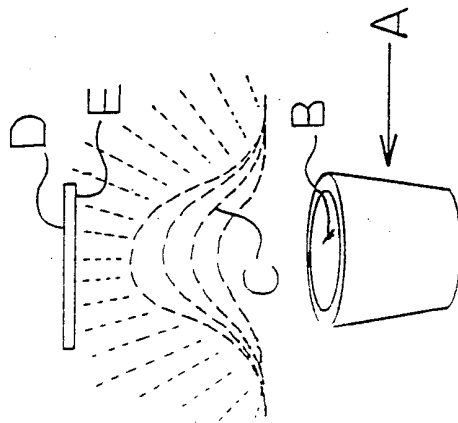
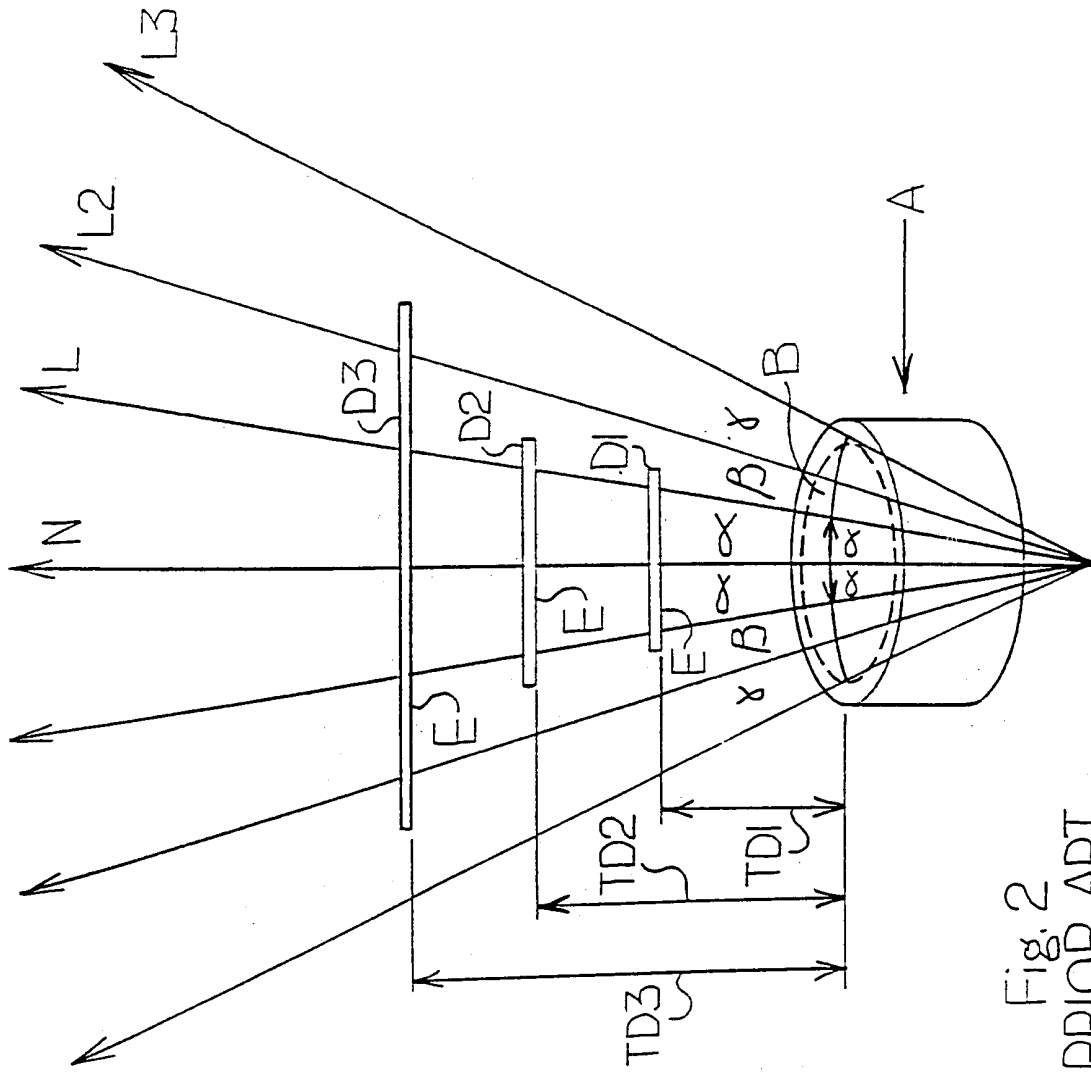

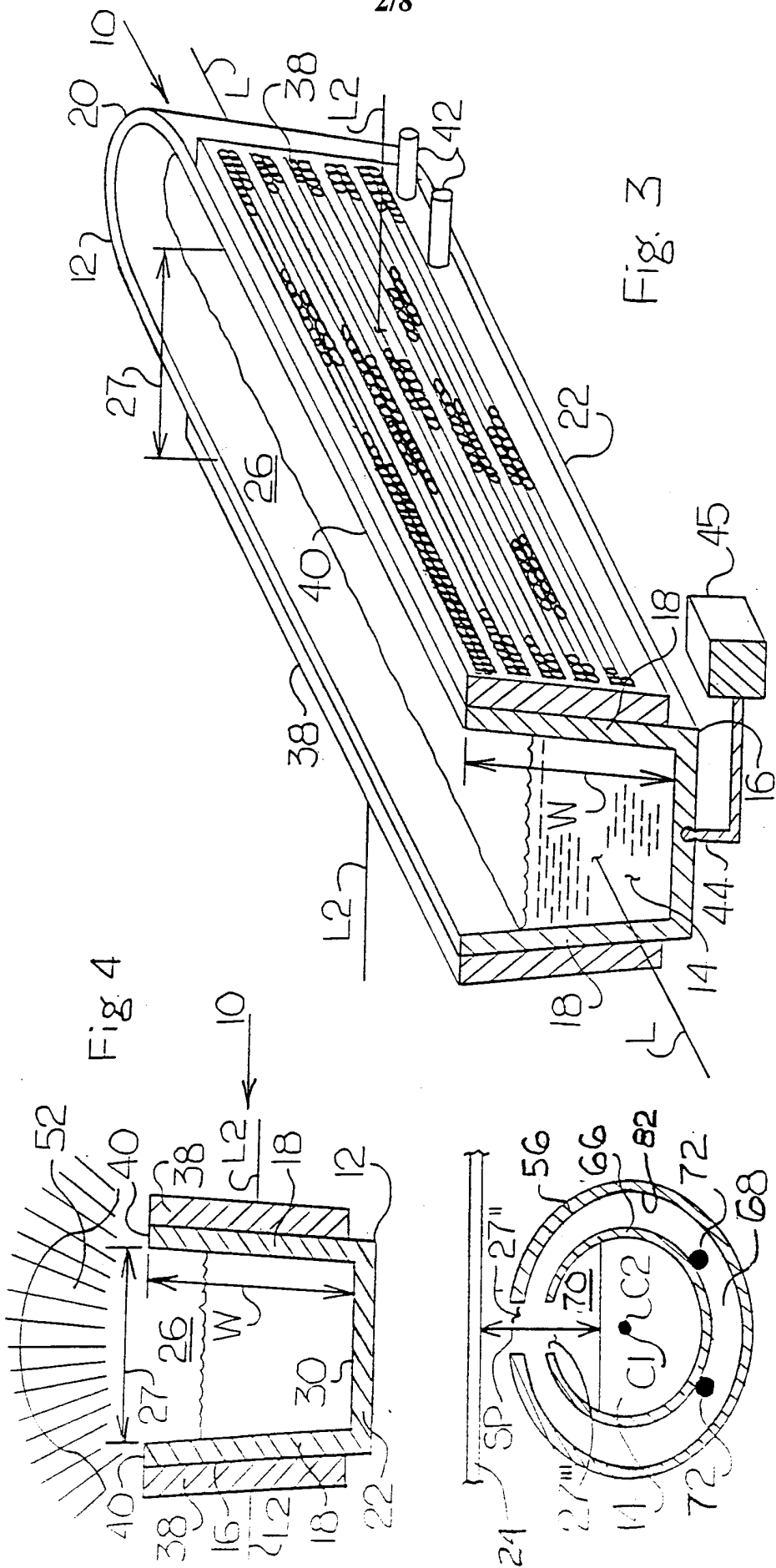

Fig. 3

Fig. 4

Fig. 12

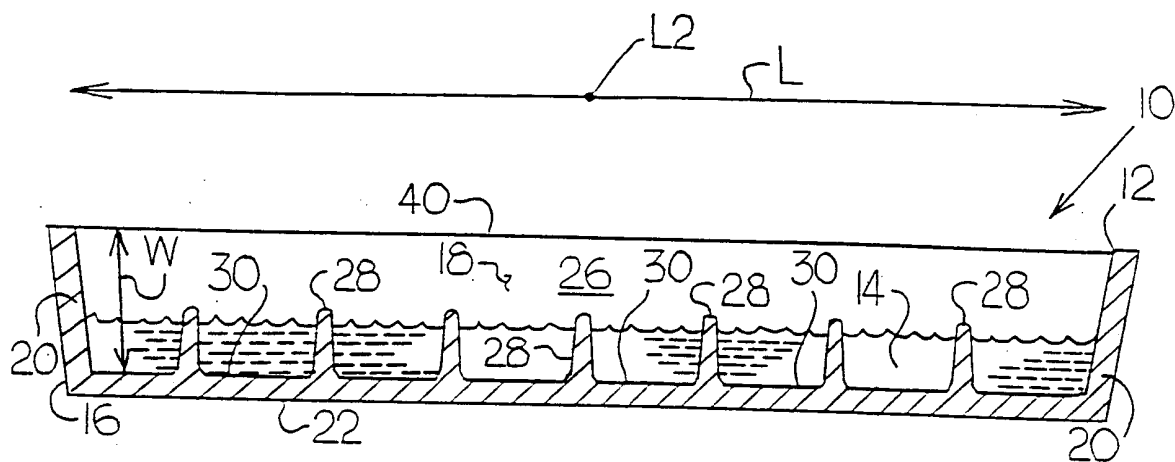

Fig. 5

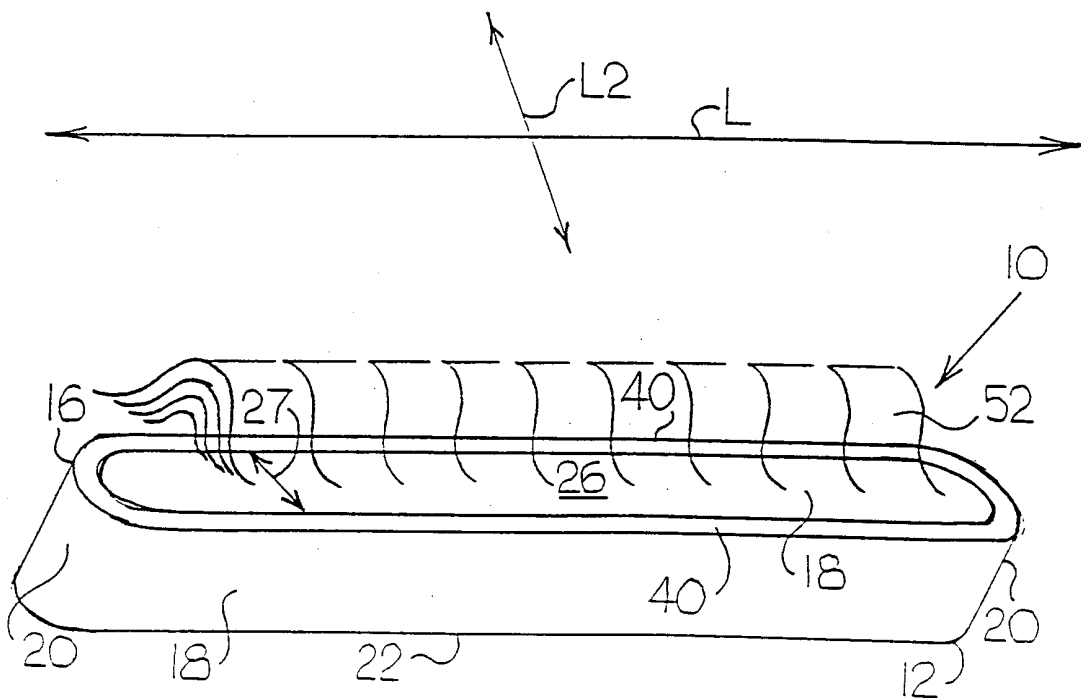

Fig. 6

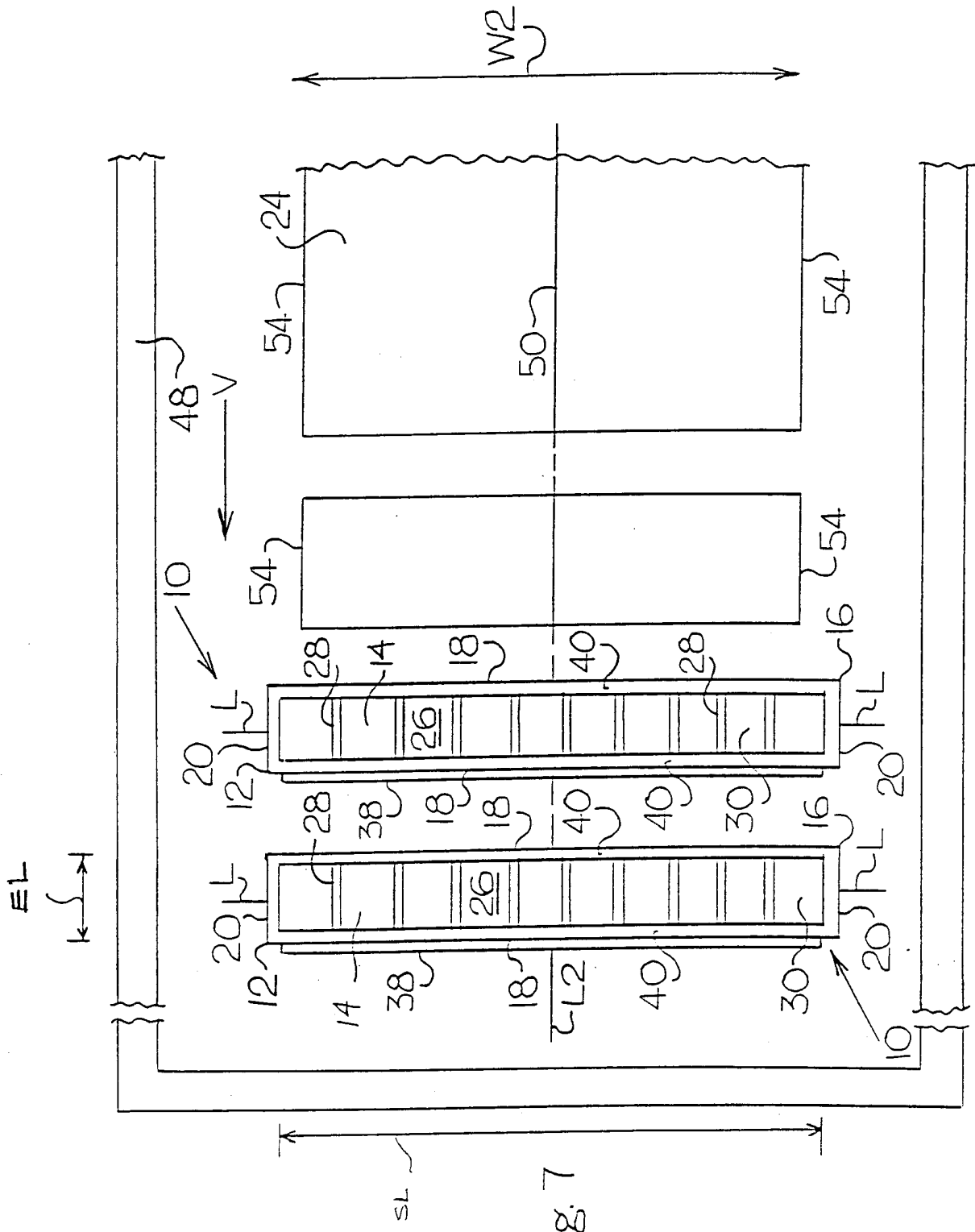

Fig. 7

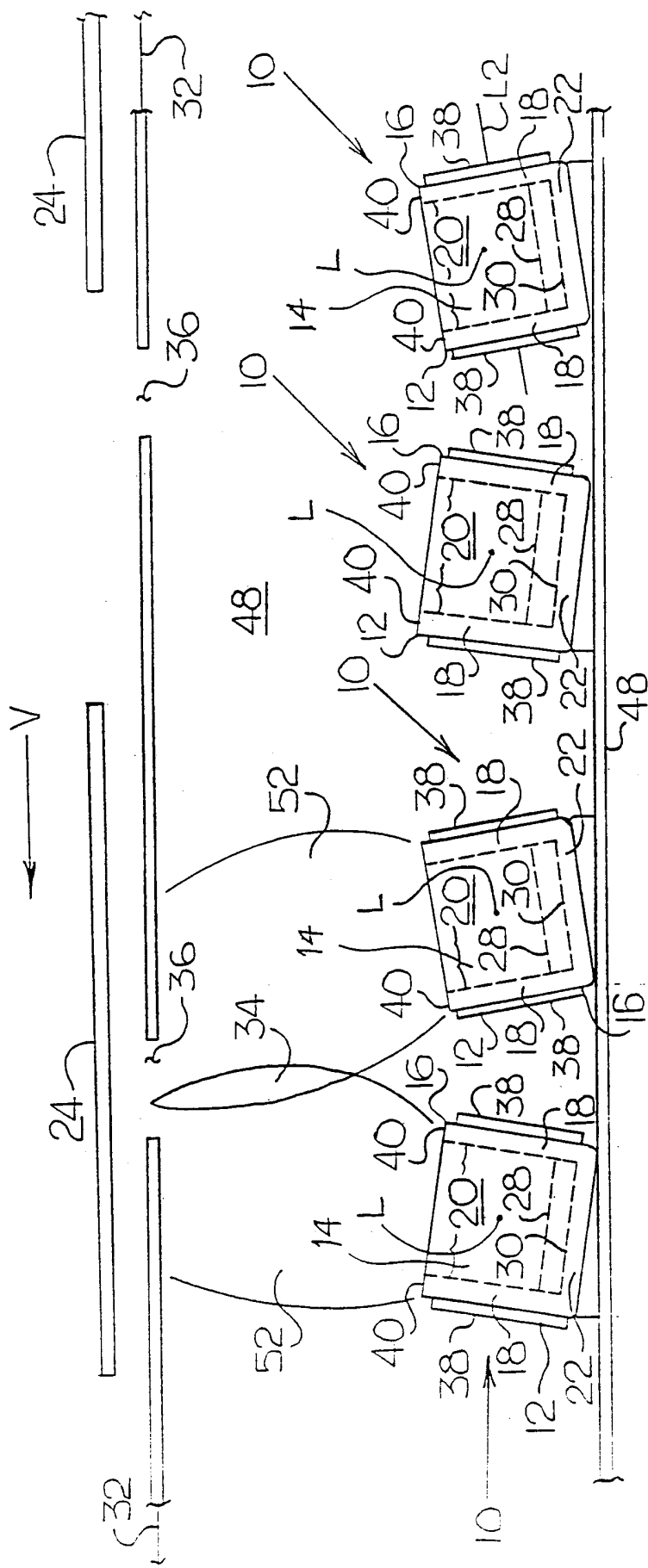

Fig. 8

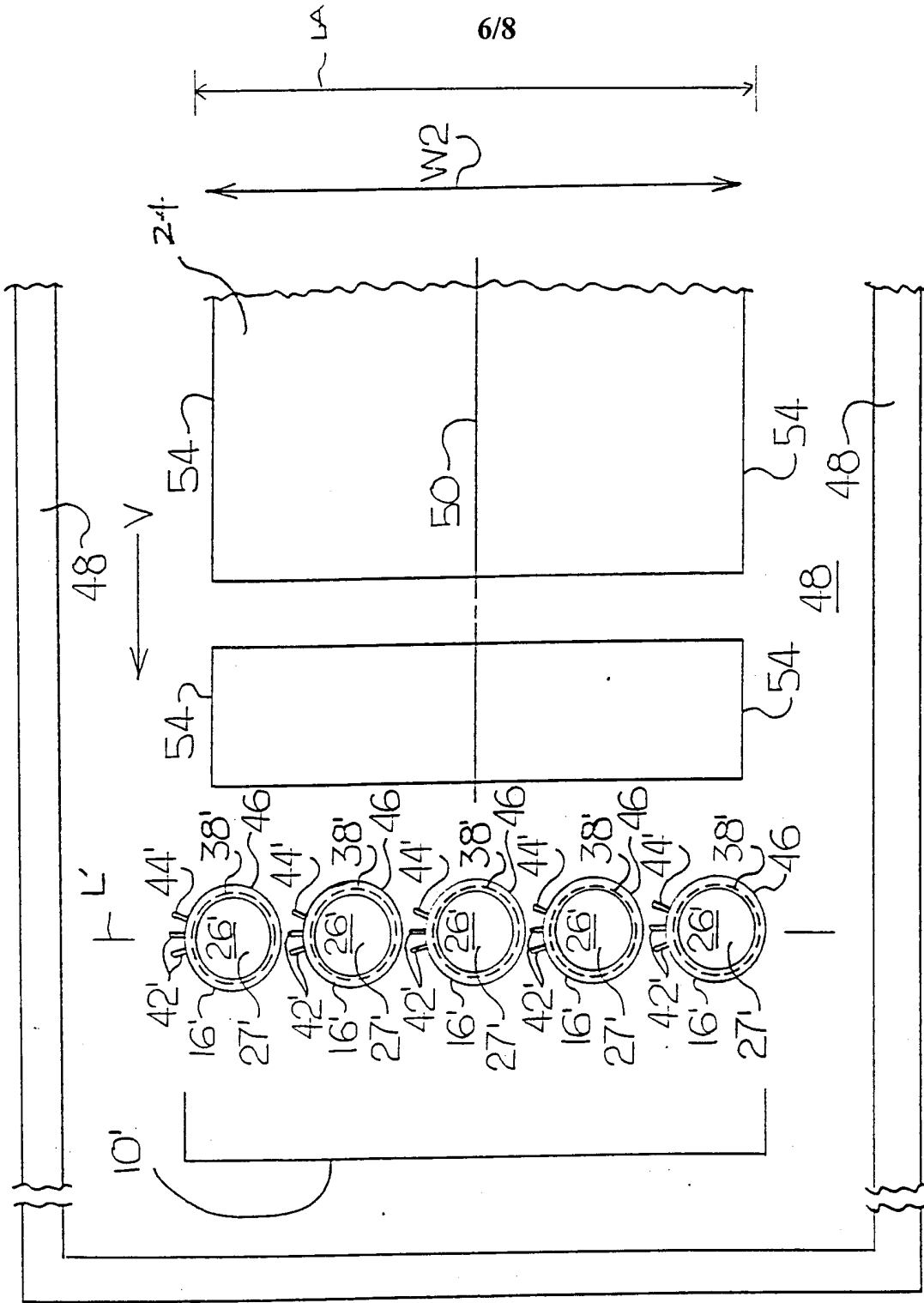
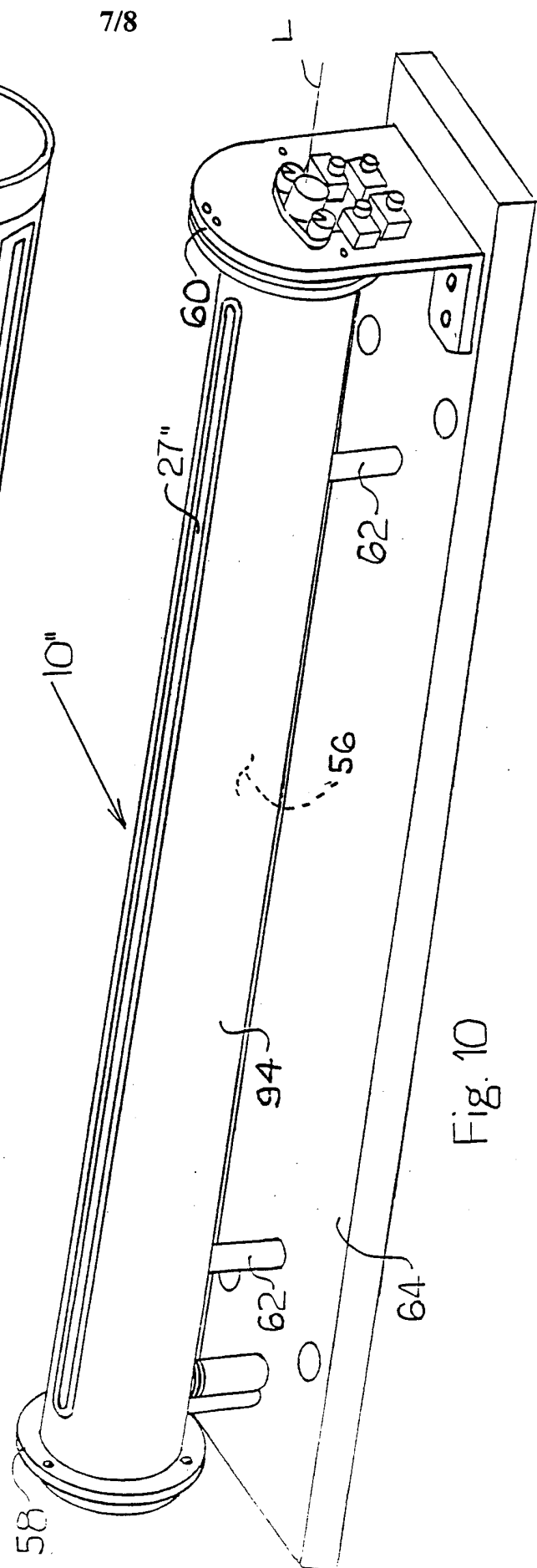
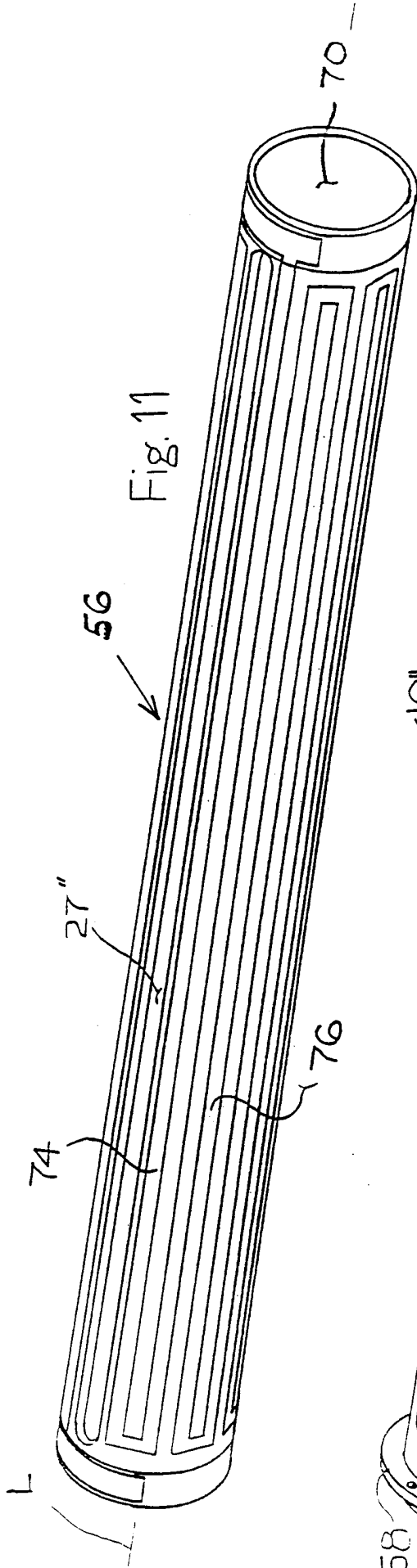

Fig. 9



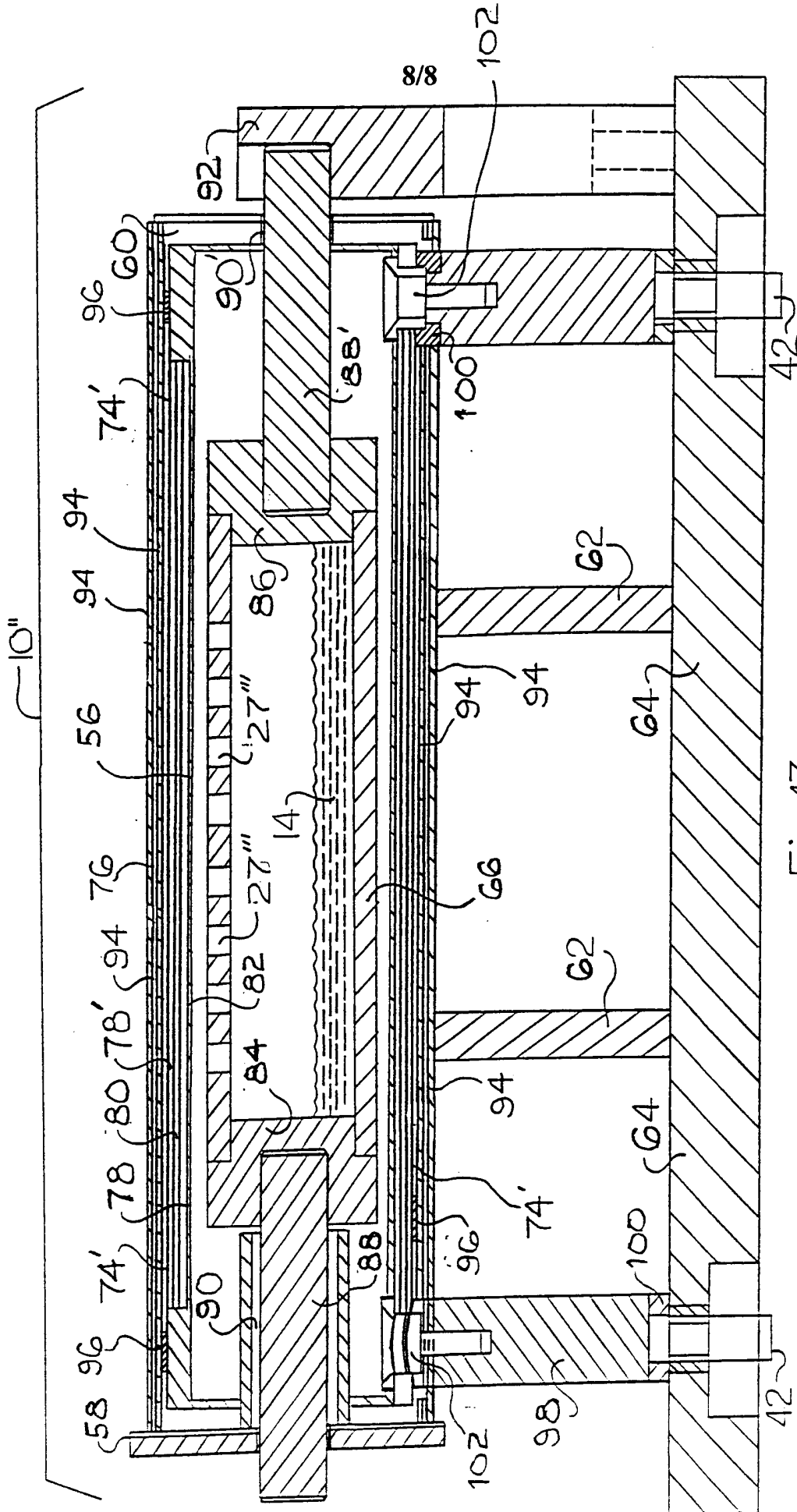

Fig. 13

INTERNATIONAL SEARCH REPORT

International application No.
PCT/US00/29099

A. CLASSIFICATION OF SUBJECT MATTER

IPC(7) : C23C 16/00
US CL : 118/726, 718, 723 VE: 427/248.1, 255.5, 255.6.
According to International Patent Classification (IPC) or to both national classification and IPC

B. FIELDS SEARCHED

Minimum documentation searched (classification system followed by classification symbols)

U.S. : 118/726, 718, 723 VE: 427/248.1, 255.5, 255.6.

Documentation searched other than minimum documentation to the extent that such documents are included in the fields searched
NONE

Electronic data base consulted during the international search (name of data base and, where practicable, search terms used)
NONE

C. DOCUMENTS CONSIDERED TO BE RELEVANT

Category*	Citation of document, with indication, where appropriate, of the relevant passages	Relevant to claim No.
X --- Y	US 4,023,523 A (ING) 17 May 1977, entire document.	1, 4, 5, 7, 11, 12, 16, 17, 23-26, 28, 29 ----- 6, 18-22
X --- Y	US 4,627,989 A (FEUERSTEIN et al) 09 December 1986, entire document.	1, 3, 5, 7, 9, 10, 12, 16-17, 23, 24, 26 ----- 2, 6, 21, 25, 28, 29

Further documents are listed in the continuation of Box C. See patent family annex.

* Special categories of cited documents:	"T" later document published after the international filing date or priority date and not in conflict with the application but cited to understand the principle or theory underlying the invention
"A" document defining the general state of the art which is not considered to be of particular relevance	"X" document of particular relevance; the claimed invention cannot be considered novel or cannot be considered to involve an inventive step when the document is taken alone
"E" earlier document published on or after the international filing date	"Y" document of particular relevance; the claimed invention cannot be considered to involve an inventive step when the document is combined with one or more other such documents, such combination being obvious to a person skilled in the art
"L" document which may throw doubts on priority claim(s) or which is cited to establish the publication date of another citation or other special reason (as specified)	"&" document member of the same patent family
"O" document referring to an oral disclosure, use, exhibition or other means	
"P" document published prior to the international filing date but later than the priority date claimed	

Date of the actual completion of the international search
04 JANUARY 2001

Date of mailing of the international search report
24 JAN 2001

Name and mailing address of the ISA/US
Commissioner of Patents and Trademarks
Box PCT
Washington, D.C. 20231
Facsimile No. (703) 305-3230

Authorized officer

JEFFRIE R. LUND
Telephone No. (703) 308-0661

INTERNATIONAL SEARCH REPORT

International application No.

PCT/US00/29099

C (Continuation). DOCUMENTS CONSIDERED TO BE RELEVANT

Category*	Citation of document, with indication, where appropriate, of the relevant passages	Relevant to claim No.
X --- Y	US 5,182,567 A (WILDER) 26 January 1993, entire document.	1, 3, 5, 7, 10, 13, 14, 18, 19, 23, 24, 26, 27, 30, 31 ----- 2, 6, 20-22, 25, 28, 29
X --- Y	US 5,302,208 A (GRIMM et al) 12 April 1994, entire document.	1, 3, 5, 7, 8, 10, 12, 16, 17, 23, 24, 26 ----- 6, 25
X --- Y	US 5,679,410 A (SUGITA et al) 21 October 1997, entire document.	1,3-5, 7, 10, 12, 16, 17, 23, 24, 26 ----- 2, 6, 25
X --- Y	US 5,803,976 A (BAXTER et al) 08 September 1998, entire document.	1, 3, 5, 7, 10, 12- 17, 23, 26, 27, 30, 31 ----- 6, 8, 18-22, 24, 25, 28, 29
Y	US 5,709,753 A (OLSON et al) 20 January 1998, abstract.	6, 22
Y	US 5,433,791 A (BREWER et al) 18 July 1995, entire document.	6, 8, 22
Y	US 4,264,803 A (SHINKO) 28 April 1981, entire document.	28, 29
Y	US 4,332,838 A (WEGRZYN) 01 June 1982, column 2 lines 39-46, and figure 1	2