



US00D562363S

(12) **United States Design Patent**
Dore

(10) **Patent No.:** **US D562,363 S**

(45) **Date of Patent:** **** Feb. 19, 2008**

(54) **VALVE AND PIPEWORK ASSEMBLY FOR AN ABRASIVE BLASTING APPARATUS**

(75) Inventor: **David James Dore**, Derbyshire (GB)

(73) Assignee: **Quill International Industries PLC**, Derbyshire (GB)

(**) Term: **14 Years**

(21) Appl. No.: **29/279,619**

(22) Filed: **May 3, 2007**

(30) **Foreign Application Priority Data**

Nov. 7, 2006 (EM) 000617196

(51) **LOC (8) CL.** **15-09**

(52) **U.S. CL.** **D15/123**

(58) **Field of Classification Search** D15/122,
D15/123, 124, 126; 239/594; 285/38, 92;
451/2, 38, 60, 87-90, 92, 99, 100, 102, 439,
451/446

See application file for complete search history.

(56) **References Cited**

U.S. PATENT DOCUMENTS

3,445,966	A *	5/1969	Moore	451/95
4,057,940	A *	11/1977	Wemmer	451/101
4,494,398	A *	1/1985	Svoboda	72/393
4,674,239	A *	6/1987	Jodoin	451/87
5,033,776	A *	7/1991	Hockett	285/238
5,054,249	A *	10/1991	Rankin	451/99
5,209,409	A *	5/1993	Neiss	239/586
D369,814	S *	5/1996	Pearlman et al.	D15/126
D389,493	S *	1/1998	Orf	D15/122
5,795,214	A *	8/1998	Leon	451/102
5,882,044	A *	3/1999	Sloane	285/92

7,118,463	B1 *	10/2006	Chen	451/89
2001/0036801	A1 *	11/2001	Taylor	451/99
2002/0175219	A1 *	11/2002	Rochat et al.	239/69
2004/0048548	A1 *	3/2004	Shepherd	451/2
2005/0233682	A1 *	10/2005	Chisum et al.	451/102
2005/0248150	A1 *	11/2005	Gilpatrick et al.	285/92
2006/0035570	A1 *	2/2006	Chisum et al.	451/99
2006/0276112	A1 *	12/2006	Davis	451/90

* cited by examiner

Primary Examiner—Antoine D. Davis

Assistant Examiner—Patricia Palasik

(74) *Attorney, Agent, or Firm*—Egbert Law Offices

(57) **CLAIM**

The ornamental design for a valve and pipework assembly for an abrasive blasting apparatus, as shown and described.

DESCRIPTION

The valve and pipework assembly for an abrasive blasting apparatus is used in a blasting apparatus having a pressure vessel adapted to contain a particulate blasting medium and a liquid.

FIG. 1 is a perspective view of the valve and pipework assembly for an abrasive blasting apparatus showing my design.

FIG. 2 is a front view thereof;

FIG. 3 is a back view thereof;

FIG. 4 is a side view thereof;

FIG. 5 is an opposite side view thereof;

FIG. 6 is a bottom view thereof; and,

FIG. 7 is a top view thereof.

1 Claim, 7 Drawing Sheets

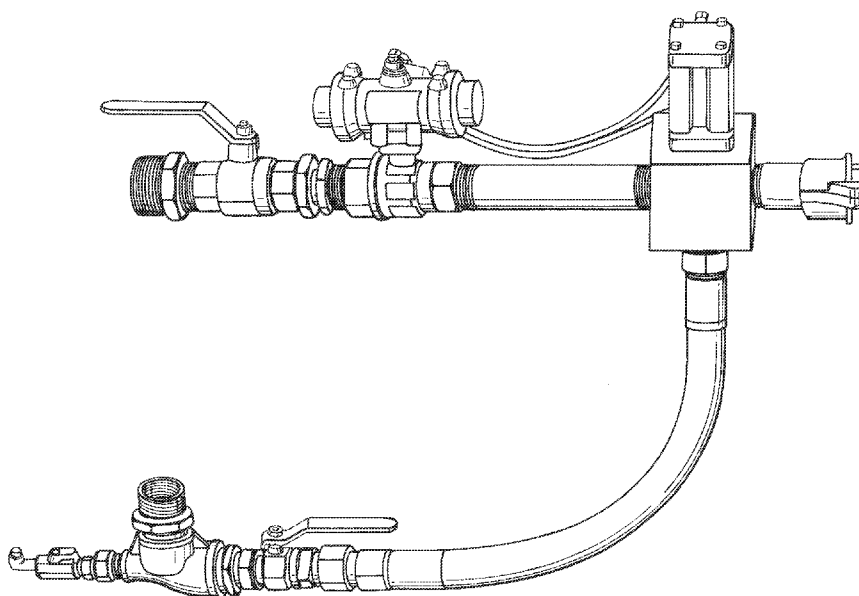

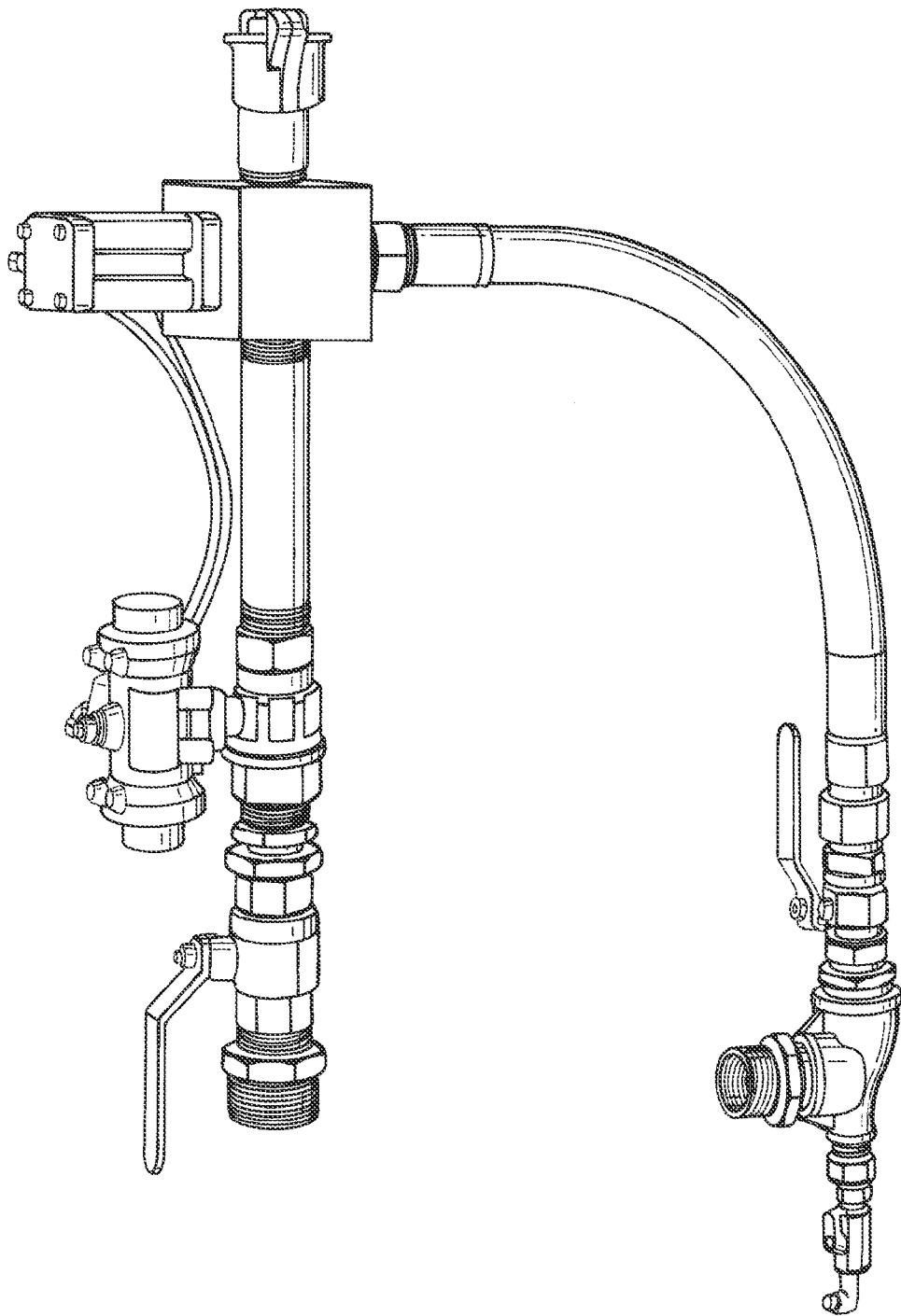

Fig. 1

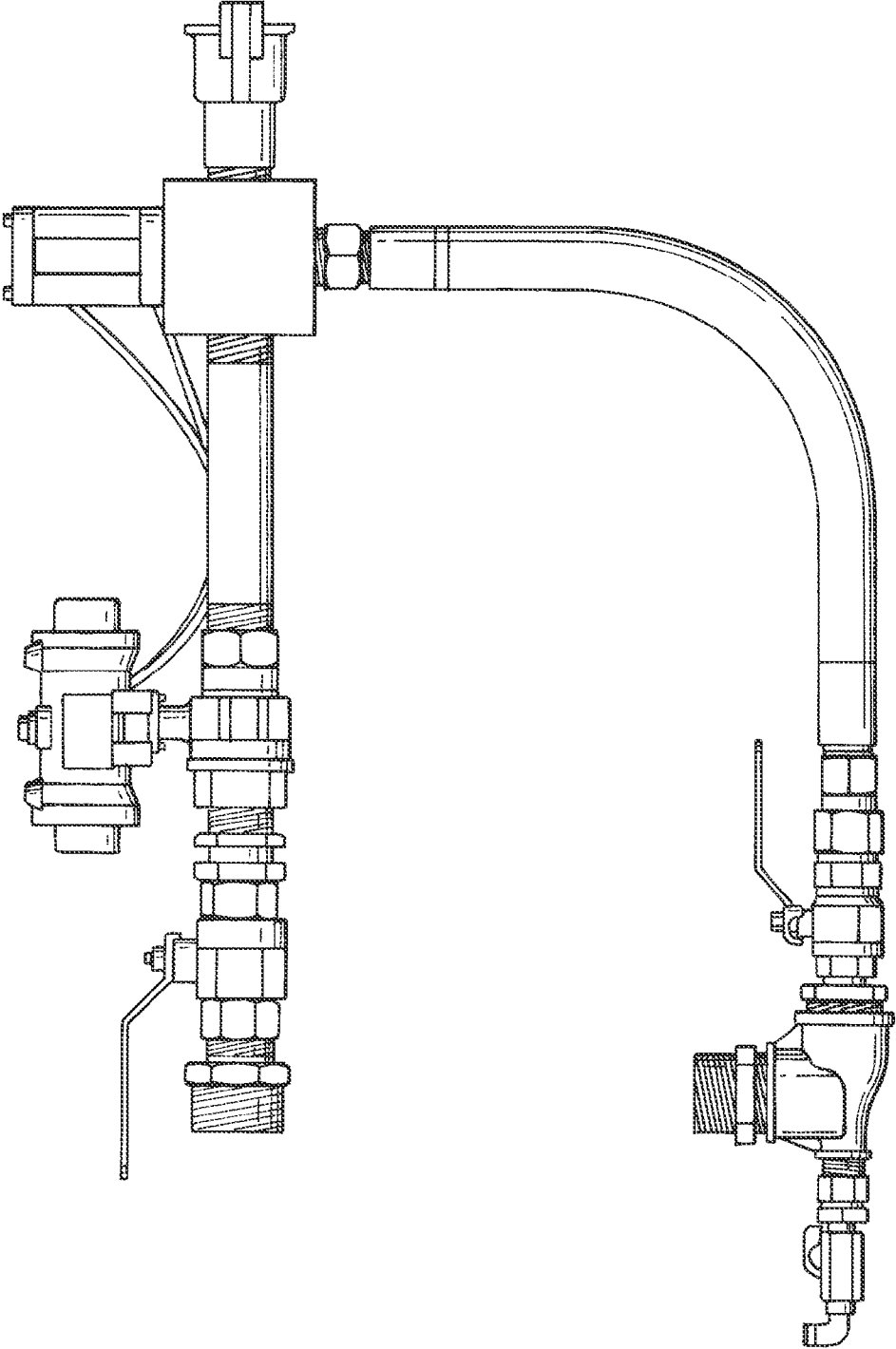

Fig. 2

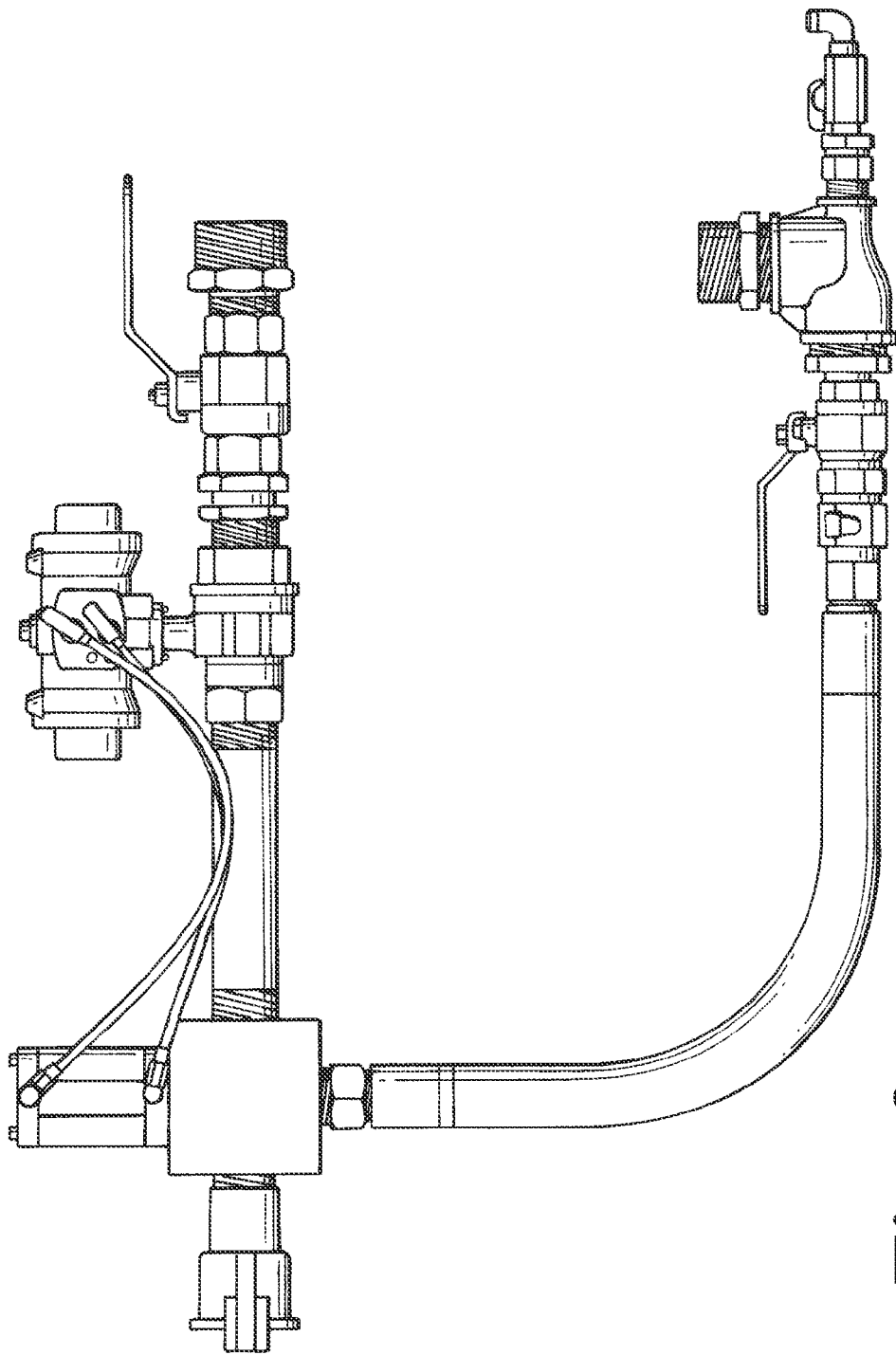

Fig. 3

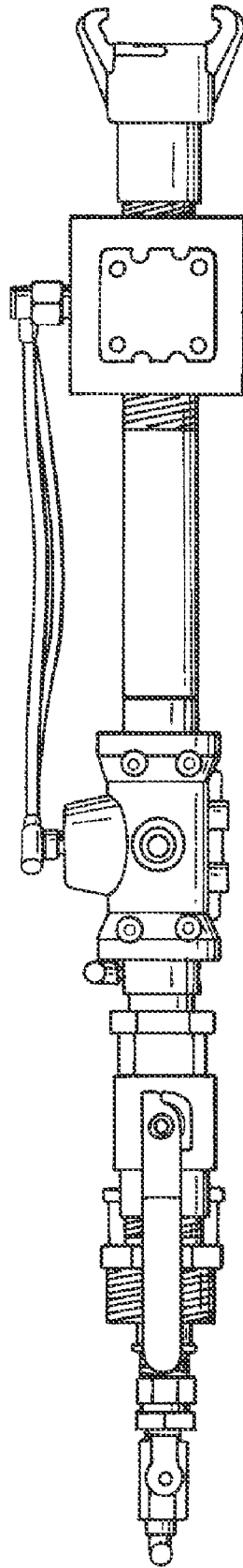

Fig. 4

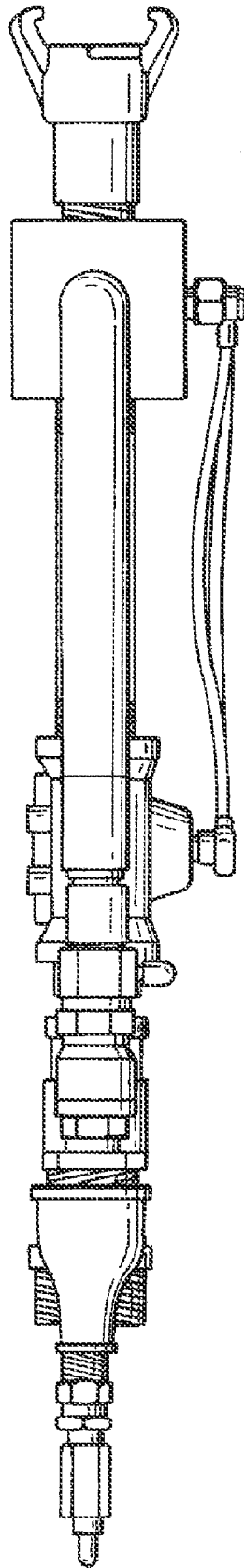

Fig. 5

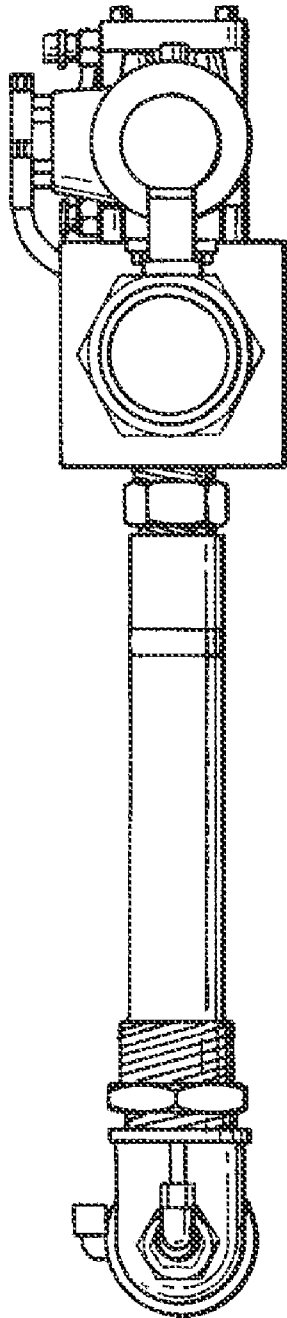

Fig. 6

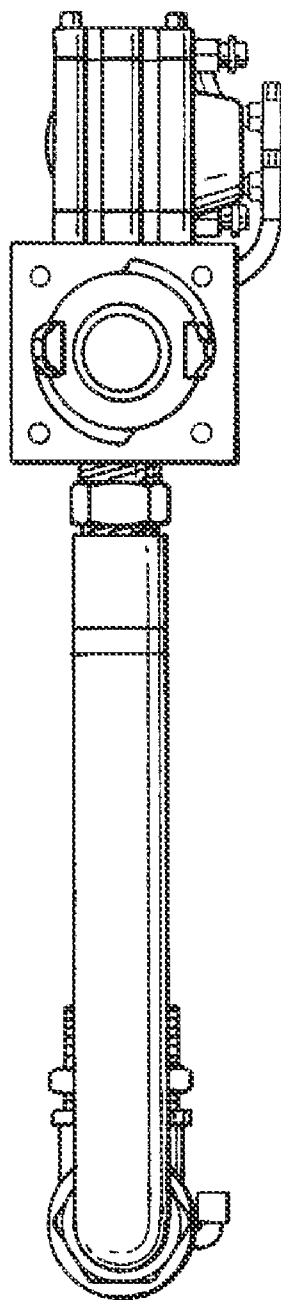

Fig. 7