



US00D410657S

United States Patent [19]

[11] Patent Number: **Des. 410,657**

Lauder et al.

[45] Date of Patent: **** Jun. 8, 1999**

[54] **GROOVED EARTH WORKING TOOL**

5,709,043 1/1998 Jones et al. 37/455

[75] Inventors: **Brian L. Lauder**, Tulsa; **Charles Clendenning**, Broken Arrow, both of Okla.

Primary Examiner—Sandra L. Morris
Attorney, Agent, or Firm—John W. Harbst

[73] Assignee: **H&L Tooth Company**, Tulsa, Okla.

[57] **CLAIM**

[**] Term: **14 Years**

The ornamental design for a grooved earth working tool, as shown and described.

[21] Appl. No.: **29/075,579**

DESCRIPTION

[22] Filed: **Sep. 3, 1997**

FIG. 1 is a perspective view of a grooved earth working tool showing our new design;
FIG. 2 is a right side elevational view thereof; with the left side elevational view being a mirror image thereof;
FIG. 3 is a top plan view thereof;
FIG. 4 is a bottom plan view thereof;
FIG. 5 is a front elevational view thereof;
FIG. 6 is a rear elevational view thereof;
FIG. 7 is a sectional view taken along line 7—7 of FIG. 3;
FIG. 8 is a sectional view taken along line 8—8 of FIG. 2; and,
FIG. 9 is a sectional view taken along line 9—9 of FIG. 2.
FIGS. 2—9 are shown on an enlarged scale. The broken line showing of the tip is for illustrative purposes only, and forms no part of the claimed design.

[51] **LOC (6) Cl.** **15-04**

[52] **U.S. Cl.** **D15/29**

[58] **Field of Search** D15/10, 22—26,
D15/28, 29, 32; 37/446, 450, 452, 455,
456

[56] **References Cited**

U.S. PATENT DOCUMENTS

| | | | |
|------------|---------|---------------------|--------|
| D. 251,431 | 3/1979 | Klett et al. | D15/28 |
| D. 336,476 | 6/1993 | Garman | D15/28 |
| 3,371,437 | 3/1968 | Wilson et al. | 37/455 |
| 4,980,980 | 1/1991 | Schadov et al. | 37/452 |
| 5,465,512 | 11/1995 | Livesay et al. | 37/455 |

1 Claim, 4 Drawing Sheets

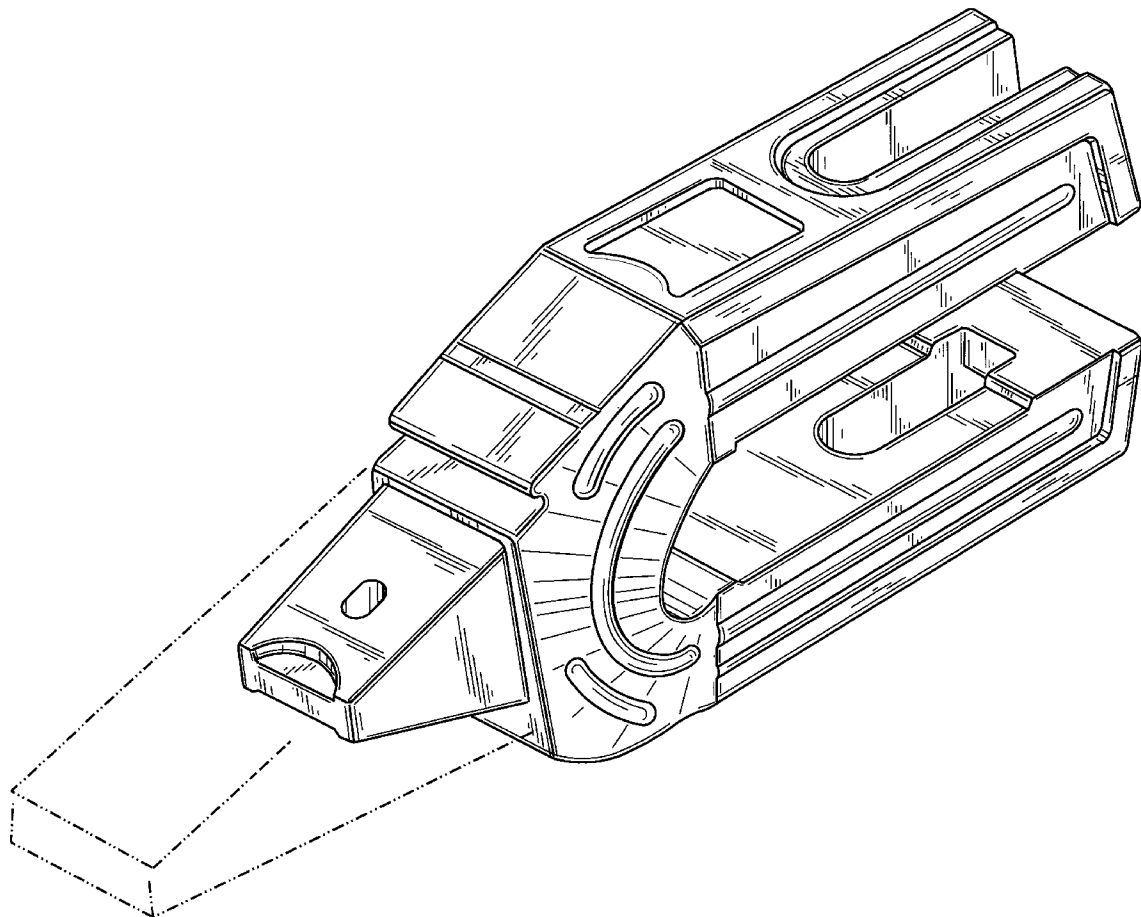

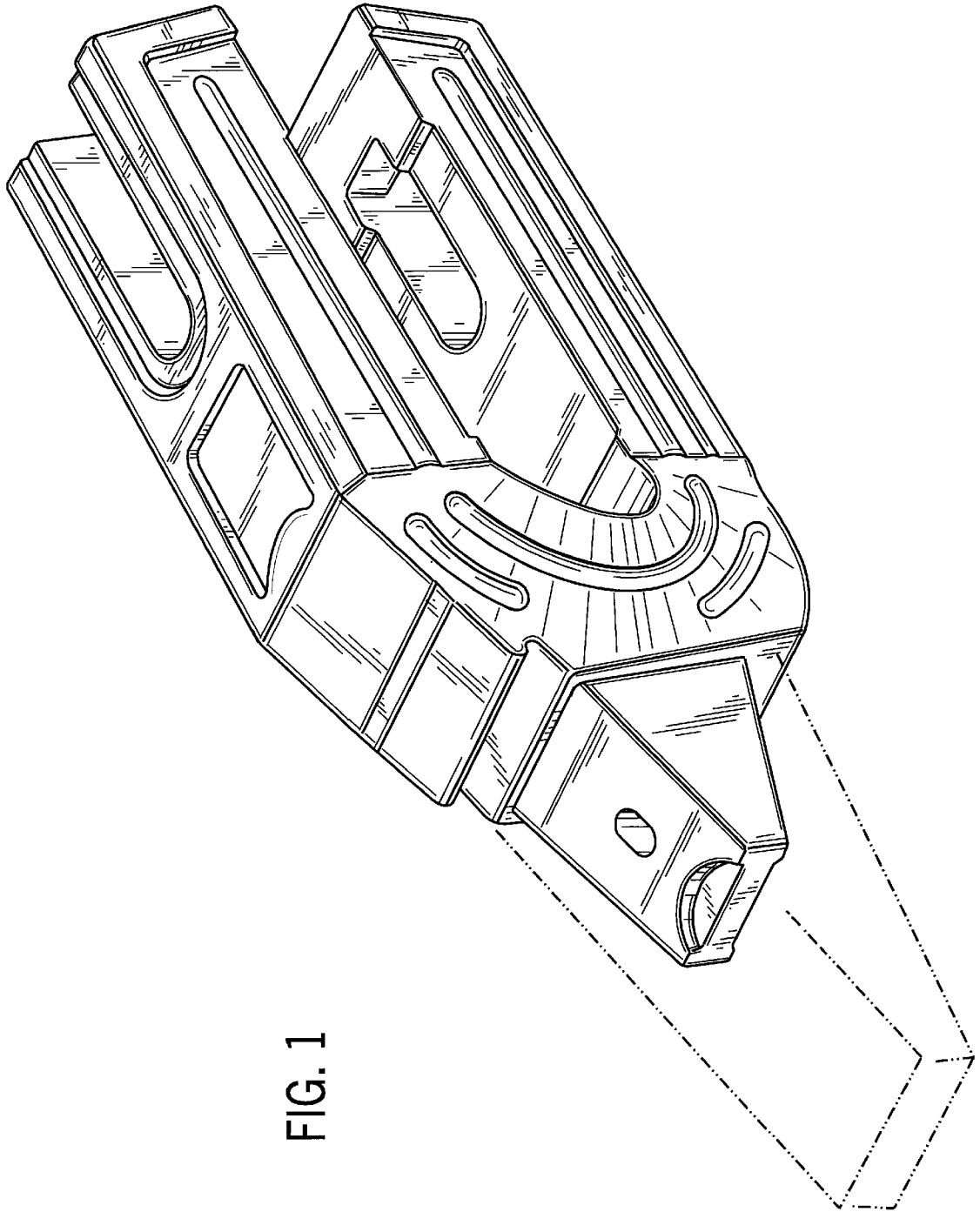

FIG. 1

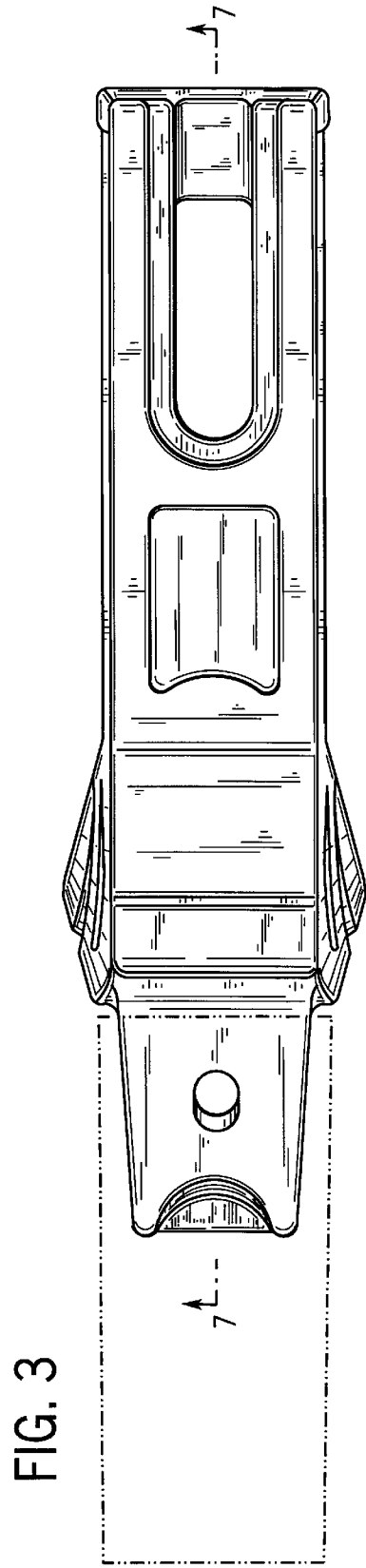
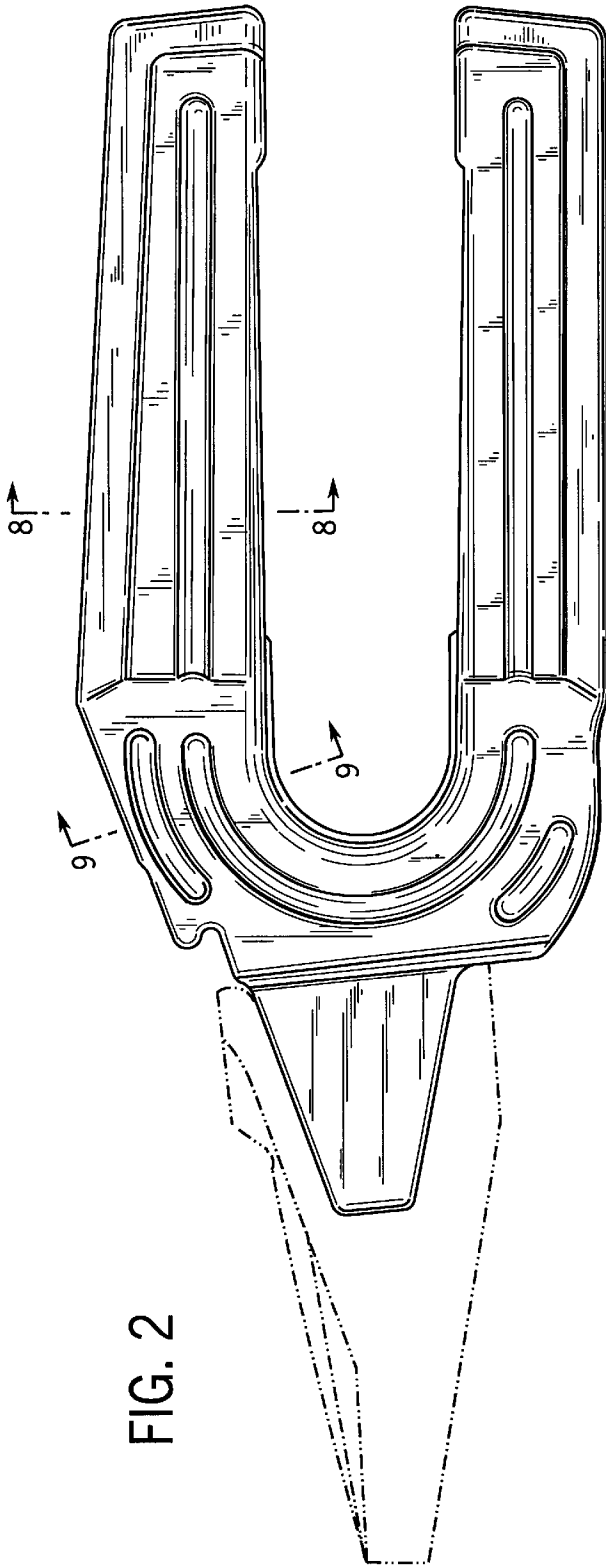

FIG. 4

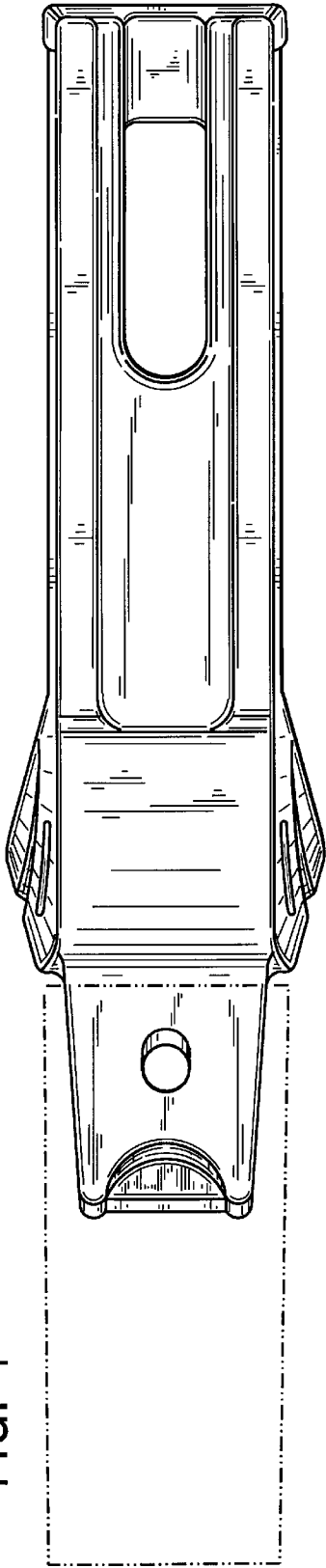

FIG. 6

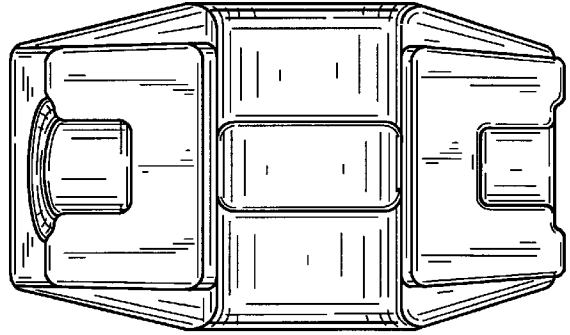
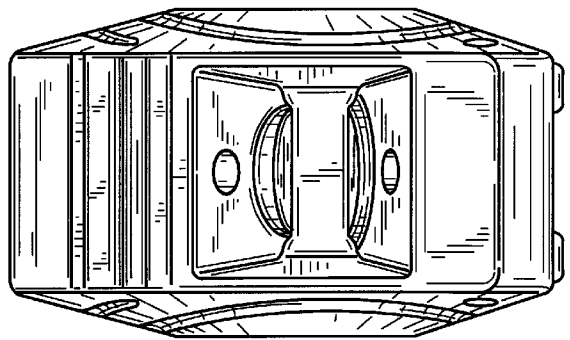

FIG. 5



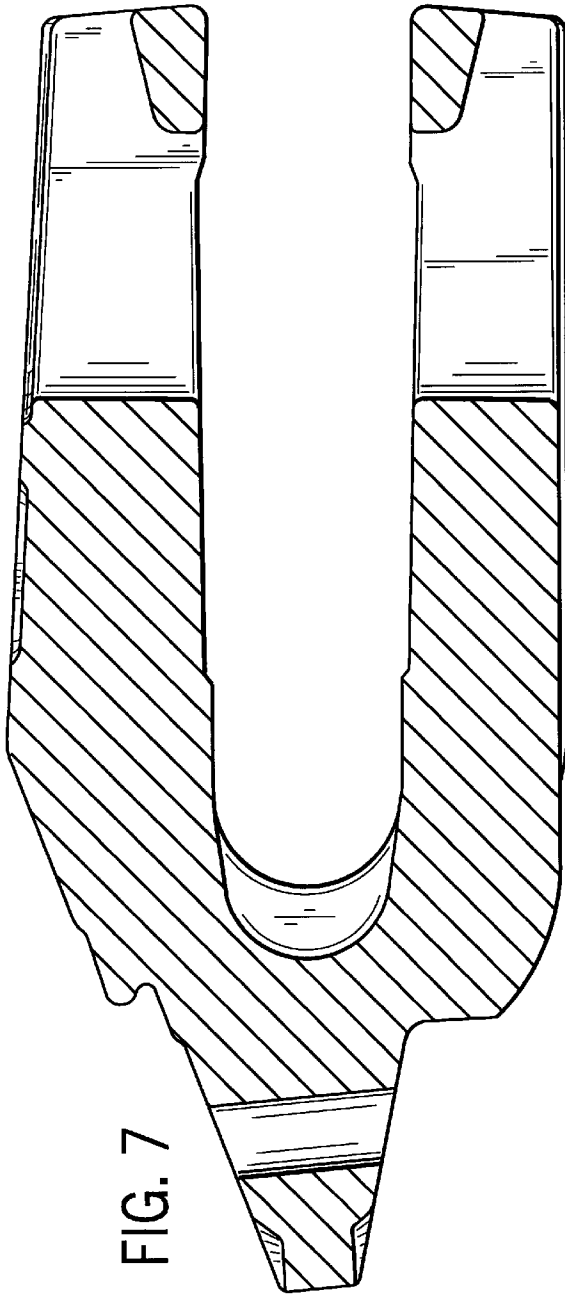

FIG. 7

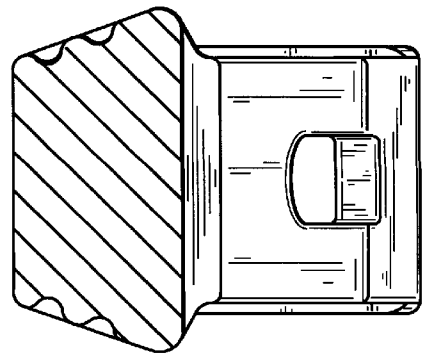

FIG. 9

FIG. 8

