

T. S. GREENMAN.
Paper-Cutting Machine.

No. 203,441.

Patented May 7, 1878.

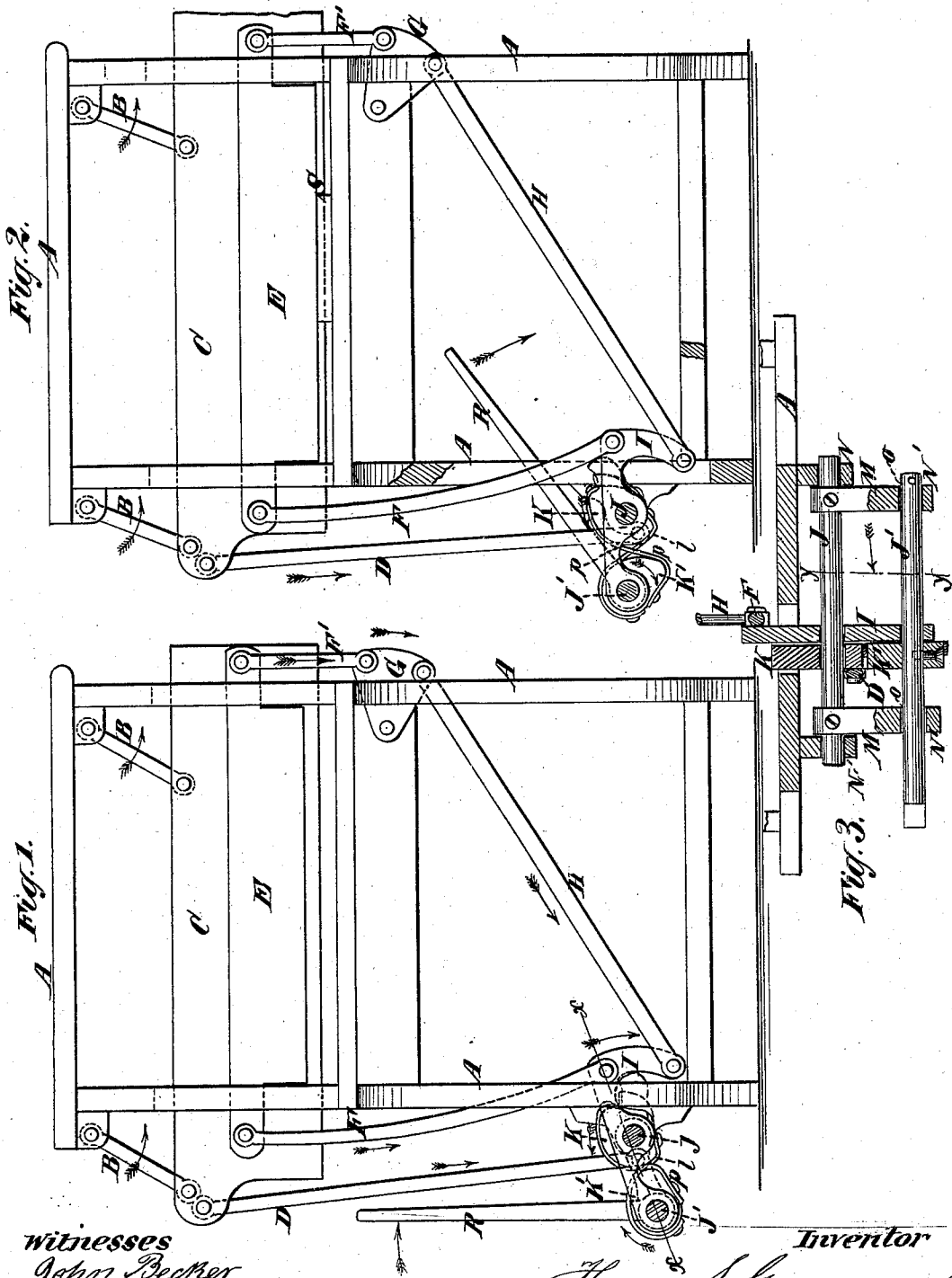

witnesses
John Becker
Geo. Haynes

Inventor
Thomas S. Greenman
by his Attorneys
Brown & Alley

UNITED STATES PATENT OFFICE.

THOMAS S. GREENMAN, OF MYSTIC BRIDGE, CONNECTICUT.

IMPROVEMENT IN PAPER-CUTTING MACHINES.

Specification forming part of Letters Patent No. 203,441, dated May 7, 1878; application filed March 25, 1878.

To all whom it may concern:

Be it known that I, THOMAS S. GREENMAN, of Mystic Bridge, in the county of New London, and the State of Connecticut, have invented an Improvement in Paper-Cutting Machines; and I do hereby declare that the following is a full, clear, and exact description of the same, reference being had to the accompanying drawing, forming part of this specification.

My invention has for its objects the construction of a paper-cutting machine in which both the upward and downward movement of the cutting blade or knife and of the clamp are caused and controlled by the lever which is used to operate the machine, thus enabling the ordinary weights or counterpoises to be dispensed with, and also to provide means for applying the power more advantageously to the performance of the work.

Figures 1 and 2 in the drawing are sectional elevations of that side of the machine on which the clamping-bar is located, the section being made on the line *y y* in Fig. 3. The said figures respectively represent the working parts of the machine in different positions. Fig. 3 is a section made on the line *x x* in Fig. 2.

A represents the frame of the machine. To the upper part of the said frame are pivoted links B, which are also pivoted to the knife C in the usual manner, giving the said knife, in its descent upon the paper, a lateral motion or drawing cut. Said knife is caused to move upward or downward and laterally by the rod or link D, operated as described hereinafter.

The clamp is represented at E. It is supported upon and operated by the links or rods F and F'. The link F' is pivoted to the rocking sector G, which is itself pivoted to the frame A of the machine. To the said rocking sector G is pivoted a rod or link, H, which is in turn pivoted to a rock-lever, I. The link F is also pivoted to the same rock-lever I. The said rock-lever rocks on the shaft J as a bearing.

So far as I have now described the machine it differs in no substantial particular from others hitherto in public use and well known to the trade; but in such machines as hereto-

fore used the rock-lever I, or some part connected therewith, has been operated by a lever in one direction, and by a weight or counterpoised lever in the other direction. By the construction hereinafter described I am able to dispense with the weighted lever, and also to apply the power of the lever to better advantage—that is to say, I am able to regulate the motion of the knife and clamp in such manner that they move rapidly and with less power during the time they are not applied to clamping and cutting, and slowly and with greater power while actually clamping and cutting the paper.

To effect these desirable results I employ the following devices: On the shaft J, upon which the rock-lever I freely plays, is fitted to play freely a cam, K, to which the link D is pivoted at *l*. To the said shaft J are keyed or otherwise rigidly attached the arms or levers M; and, as the said shaft J rocks in bearings N, rigidly attached to the frame A, the said arms M are properly rock-levers and the said shaft J is a rock-shaft. In the said arms or levers are formed bearings N' for another rock-shaft, J', which passes easily through a hole, *o*, in the outer extremity of the rock-lever I, and which has keyed or otherwise rigidly attached thereto another cam, K'. The said cams K and K' have similar contours. The cams so constructed and arranged on the shafts J J' are connected by chains *p p* or other flexible but inelastic connectors, such as metal or other inelastic straps, wire rope, &c.; or irregular-shaped gears having the same general outline as the cams, or circular gears eccentric to their shafts, may be used as equivalents of the said cams. Each of the said cams is so adjusted on the shafts J J', and so connected by the connectors *p p*, that the distance of its periphery from its center, measured on the line which joins the centers of both in different positions, increases on one in precisely the same degree as it decreases on the other, and vice versa, so that when one cam is turned, by turning the other there is a constantly-varying ratio between the radial velocities of the two cams, in favor of the purchase of the lever R on the shafts J J' when the same is actuated in the direction to make the knife

and clamp descend upon the paper for clamping and cutting the same. The said knife and clamping-bar, therefore, move least rapidly and with greatest power toward the last part of the downward movement, when the greatest power is required.

It will be seen that this construction enables the centers of the shafts J J' to be placed at any desired distance apart without in any degree affecting the purchase of the lever R upon the knife C, which is not the case in a rack-and-pinion movement, such as has heretofore been used.

The operation of the machine is as follows, S representing a bundle of paper to be cut: The lever is seized by the operator and raised vertically, which rocks the rock-lever I on the shaft J and brings the clamping-bar down upon the paper S. The lever R is then turned on the shaft J' to rotate the cam K' in the direction indicated by the arrows. This, through one of the flexible connectors p p, rotates the cam K in the opposite direction, and, with great and increasing force transmitted through the link D, draws the knife downward to cut the paper. The clamping-bar is also pressed upon the paper, to hold the same with a gradually-increasing force till the knife completes the cut, when the above-described movements are reversed by reversing the movement of the lever R.

I do not, however, confine myself to the hand-lever R for operating the machine, as a gear, or pulley, or other means for imparting motion to the shaft J', may be employed; and as there may be other means of imparting a varying radial velocity ratio from the shaft J' to the shaft J, I do not limit myself to the precise means herein described for accomplishing this result; but

What I consider as my invention, and desire to secure by Letters Patent, is expressed in the following claim:

The combination, with the clamping-bar and knife of a paper-cutting machine, the rock-lever I and devices, substantially as herein described, for transmitting motion from the said rock-lever to the said clamping-bar and knife, of a shaft for imparting motion to the working parts of the machine and connected cams K K', or equivalent transmitters of motion, which intervene between the said shaft and clamping-bar and knife, and which have a varying radial velocity ratio, increasing the purchase upon the said clamping-bar and knife toward the end of their downward movement, substantially as and for the purpose specified.

THOS. S. GREENMAN.

Witnesses:

FRED. HAYNES,
VERNON H. HARRIS.