

April 11, 1961

A. J. COLLINS

2,979,239

SPOUT WITH SEALING COVER THEREFOR

Filed Nov. 29, 1956

*Fig. 1*

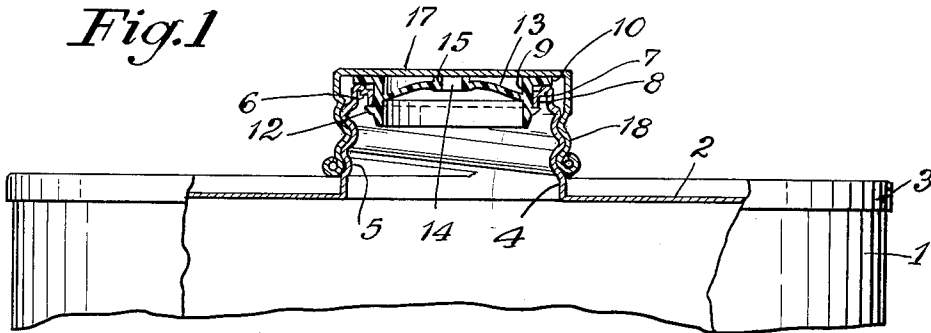

*Fig. 2*

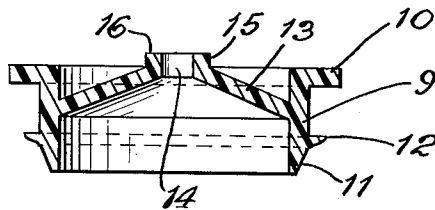

*Fig. 3*

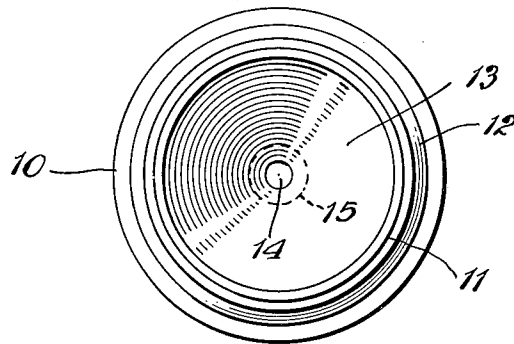

*Inventor*  
*Arthur J. Collins*  
*by Parker & Carter*  
*Attorneys*

1

2,979,239

**SPOUT WITH SEALING COVER THEREFOR**

Arthur J. Collins, 6023 N. Sauganash Ave.,  
Chicago 30, Ill.

Filed Nov. 29, 1956, Ser. No. 625,062

2 Claims. (Cl. 222—530)

This invention relates to a spout and particularly to a spout suitable for a dispensing can or other container. It has for one object to provide a simple structure of relatively flexible material which may be readily inserted in an opening in a container.

It has for another object to provide a spout structure which will be retained in an opening in a container without fastening means, but by its shape, size and construction alone.

Another object is to provide a spout which may be readily inserted into an opening in a container and which holds itself in place and in sealing contact therein without added joining or fastening means.

A further object is to provide a spout of the type just mentioned so arranged that upon the application of an outer closure its sealing effect will be augmented in cooperation with the outer closure.

Another object is to provide, in combination, a container and spout so arranged that the spout will, by its shape alone, be retained in sealing engagement with that portion of the container which it touches even when the container is open for discharge of its contents, and to provide in combination with the container a closing cover member which, when in place, cooperates with the spout further to increase the sealing effect and to make sealing contact with the spout itself.

Other objects will appear from time to time throughout the specification and claims.

The invention is illustrated more or less diagrammatically in the accompanying drawings wherein:

Fig. 1 is a sectional view of a portion of a can or container with the spout of the present invention in place, and the closing cap also in place;

Fig. 2 is an enlarged sectional view of the spout removed from the container; and

Fig. 3 is a bottom plan view of the spout of Fig. 2.

Like parts are designated by like characters throughout the specification and drawings.

In the particular form shown the spout of this invention is positioned in the opening of the container which, as shown, would normally be called "a can." It may be of metal or other material. As shown, the body of the container 1 is provided with a top closure 2. A flange 3 is formed in the closure 2 and shaped as shown in Fig. 1 to grip the upper edge of the portion 1 to hold the top and the container together. It may be soldered or merely crimped in place, or both.

Extending upwardly from the member 2 is a neck 4 which may be integral with the member 2 or separately made and secured thereto. The neck portion 4 is threaded as at 5. Adjacent its upper end it is inwardly bent as at 6 and a relatively flat flange portion 7 may be formed with an integral skirt or neck 8. The particular details of the neck construction of the container form no essential part of the invention. These parts might be of other sizes, shapes and proportions and they might

2

be made all integral with the cover 2 or they might be separate and secured together.

The spout itself is formed of relatively flexible and elastic material. It may be formed of materials of the general class designated as polyethylene. It may also be made of rubber, nylon, dylon, and many other comparable materials. It is sufficient for the purposes of the invention that the material used be somewhat flexible and elastic; that it be substantially inert in the presence of the material which is to be contained within the container, and that it have sufficient strength when inserted in the opening in the container to maintain itself in tight engagement with that portion of the container with which it is in contact.

As shown, the spout comprises a neck portion 9 which at its outer end terminates in a flange 10. At its lower end it may be tapered as at 11 and is provided with an outwardly directed bead 12. The precise shape of the flange 10 and the bead 12 form no essential part of the invention. The two comprise together, in effect, a pair of beads or engaging members for engagement with a part of the container. It is sufficient, if their shape and location be such, that they engage the container when in place. The spout comprises also an integral disklike member 13. As shown in Fig. 1 and in greater detail in Fig. 2, this is a conical member provided with a perforation 14 about which an outwardly extending raised portion 15 is positioned. The upper or outer surface of the member 15 comprises a relatively flat area 16 which is upwardly beyond the upper surface of the flange 10.

While the disklike member 13 is generally conical in the form shown, it might be curved and if it were curved it would be of substantially concavo-convex shape.

In the particular form shown the disk is bowed or curved outwardly away from the interior of the container and it is provided about the perforation with a thickened portion or an extension. As shown in Figs. 1 and 2, this is the portion 15 and it extends above the upper or outward surface of the flange 10. The portion 15 might be omitted but a part of the disk structure, either the portion 15 or the disk itself, should extend outwardly beyond the upper surface of the flange 10. Although the structure shown is the preferred form, the disk itself might be bowed inwardly instead of being bowed outwardly as shown. In that case the thickened portion 15 would be lengthened so that it would extend above the outer surface of the flange 10. Thus, whatever the form of the disk may be, some part of the disk structure, either the disk itself or the member 15 around the perforation in the disk, will extend outwardly beyond the upper surface of the flange 10 so as to be contacted by the closure cap when the latter is in full closing position.

The diameter of the neck portion 9 of the spout structure is preferably slightly greater than the internal diameter of the neck 8 of the container. Although this is preferable, it is not necessary. The external diameter of the portion 9 may be the same as the internal diameter of the portion 8. The distance between the lower face of the flange 10 and the upper face of the bead 12 is substantially the same as the length of the neck 8. Obviously the diameter of the flange 10 and the diameter of the bead 12 are greater than the internal diameter of the portion 8.

When the spout is to be put in position, it is snapped or sprung into position in the neck portion 8 of the container. The material of which the spout structure is made is sufficiently elastic to permit distortion and it is thrust or "snapped" into place in the neck 8. As this occurs the neck 9 may be distorted or the bead 12 may be distorted, or both may be distorted. When the spout structure has been thrust far enough into the neck 8 so that

3

the bead 12 clears the bottom edge of the neck 8, it resumes its former shape and fits as shown in Fig. 1 along the bottom of the member 8. The flange 10 fits over the top of the upper edge of the neck 4 and the bead 12 and the flange 10 serve to hold the spout structure against longitudinal displacement within the neck 8.

As above mentioned, the external diameter of the neck portion 9 is larger than the internal diameter of the neck portion 8 and thus the disk 13, whether it be of conical or concavo-convex, or other shape, is under compression. It tends to resume the shape which it would occupy if it were not under compression and, hence, it exerts a pressure against the inner surface of the neck 8 of the container. The disk 13 thus acts at all times while the spout structure is in place in the container opening, to force the spout into sealing engagement with the neck portion 8 of the container.

When the container is to be fully closed, a cap 17 is seated upon the neck 5 of the container. This cap may be threaded as at 18 and thus it is in screw-threaded engagement with the neck portion 5 of the container. As shown in Fig. 1, the cap 17 is in contact with the surface 16 of the portion 15. This surface normally extends above the surface of the flange 10 when free to do so.

As the cap 17 is initially screwed or otherwise moved into closing position it contacts the surface 16 of the member 15. If there is sufficient pressure, this will be a sealing contact. As the cap is moved further down until it has reached the inner limit of its movement with respect to the container neck 4, 5, it tends to flatten the disk 13 to force it downwardly. As this occurs, the compression exerted through the disk 13 upon the neck 9 of the spout is increased and the sealing effect of the neck 9 on the neck 8 is substantially increased. The application of the cap thus increases the sealing effect of the total spout structure within the neck of the container. At the same time the sealing effect between the surface 16 and the inner face of the cap 17 is progressively increased as the cap is moved farther and farther to its complete inner position.

At the limit of its inner movement the cap 17 comes to rest with its inner surface pressed against the upper surface of the flange 10 with an additional sealing effect. The final position of the cap 17 is, therefore, one which brings it into sealing contact with the surface 16 about the opening in the disk and also brings it into sealing position and contact with the flange 10 so that a double sealing effect is produced by the ultimate contact and seating of the spout and the cap. At the same time the added distortion of the disk 13 caused by the full inner movement of the cap 17 results in an increasing compression of the neck 9 against the neck 8 and hence an increasing sealing effect at this point.

The spout thus furnishes a simple construction which may be readily inserted in an opening in a container and which, by reason of its shape, will fit tightly in the container neck or opening. When the closing cap is removed the spout, by its shape and under the influence of the disk 13 will maintain an adequate leakproof or sealing contact between the spout and the neck or other portion of the container against which it is seated. When the closure cover is in final position leakage through the normal discharge opening 14 of the spout is prevented by reason of the tight contact of the surface 16 with the inner surface of the closure cap and leakage past the outer edges of the skirt portion of the spout is additionally prevented by the contact of the closure cap with the upper flange of the spout and by the added compression as exerted on the neck portion of the spout when the closure cap forces the disk inwardly and thus by distorting the disk causes it to press outwardly against the neck of the spout and thus to press the neck of the spout against the neck of the container with constantly increasing force. This force is increased constantly from the time of first contact of the

4

inner surface of the closing cap with any part of the spout until that inner surface of the closing cap is finally firmly seated on the upper flange of the spout. Since the whole spout is made of material which is flexible, elastic and somewhat compressible, the positioning of the closure cap against the upper flange of the spout accomplishes an effective seal at that point as well.

Where the expression "bowed disk" is used it is to be understood as meaning a disk which is shaped so that it is not flat or precisely flat. The word "bowed" is to be taken as referring to a conical disk, a curved disk of curved cross section, a disk which is a truncated cone, or any equivalent shape.

Although an operative form of the device has been shown, the invention is not limited to the particular details shown. Many changes may be made in the form, shape and arrangement of parts without departing from the spirit of the invention.

I claim:

1. In combination, a hollow container having a discharge neck, means defining an inwardly positioned skirt-like portion in said neck, and a separable discharge spout, said spout being formed of elastic material and comprising a cylindrical portion terminating at one end with a laterally extended flange and having below said flange a second laterally extending flange, said spout including also a bowed, resilient, integral disk-like portion having semi-rigid characteristics, said disk-like portion being bowed outwardly with respect to said cylindrical portion and extending upwardly beyond the surface of said first mentioned flange, said disk-like portion being provided with a perforation, said spout when in position within said skirtlike portion being in sealing contact therewith, the first mentioned flange extending laterally above said skirtlike portion, said cylindrical portion being in contact with said skirtlike portion and the second flange being positioned against the lower end of said skirtlike portion to cooperate in holding said spout in position, and a cap adapted to be removably secured to said neck and to contact the upwardly extending portion of said spout to exert pressure on said spout for sealing about said perforation and additionally to tend to flatten said disk and thereby to increase the compression and sealing effect of said cylindrical portion within said skirtlike portion.

2. In combination, a hollow container having a discharge neck, means defining an inwardly positioned skirt-like portion in said neck, and a separable discharge spout, said spout being formed of elastic material and comprising a cylindrical portion terminating at one end with a laterally extended flange, said spout including also a bowed, resilient, integral disk-like portion having semi-rigid characteristics, said disk-like portion being bowed outwardly with respect to said cylindrical portion and extending upwardly beyond the surface of said flange, said disk-like portion being provided with a perforation, said spout when in position within said skirtlike portion being in sealing contact therewith, the flange extending laterally above said skirtlike portion, said cylindrical portion being in contact with said skirtlike portion, and a cap adapted to be removably secured to said neck and to contact the upwardly extending portion of said spout to exert pressure on said spout for sealing about said perforation and additionally to tend to flatten said disk and thereby to increase the compression and sealing effect of said cylindrical portion within said skirtlike portion.

#### References Cited in the file of this patent

##### UNITED STATES PATENTS

2,630,944	Wheaton	Mar. 10, 1953
2,661,128	Rieke	Dec. 1, 1953
2,804,242	Borah	Aug. 27, 1957
2,812,120	Beall	Nov. 5, 1957
2,889,079	Livingstone	June 2, 1959