



INTERNATIONAL APPLICATION PUBLISHED UNDER THE PATENT COOPERATION TREATY (PCT)

<p>(51) International Patent Classification <sup>6</sup> : <b>E21B 23/00, 7/06</b></p>	<p><b>A1</b></p>	<p>(11) International Publication Number: <b>WO 95/33913</b> (43) International Publication Date: 14 December 1995 (14.12.95)</p>
<p>(21) International Application Number: PCT/GB95/01196 (22) International Filing Date: 25 May 1995 (25.05.95) (30) Priority Data: 08/254,714 6 June 1994 (06.06.94) US (71) Applicant (for all designated States except MW): ATLANTIC RICHFIELD COMPANY [US/US]; 2300 West Plano Parkway, Plano, TX 75075 (US). (71) Applicant (for MW only): ARCO BRITISH LIMITED [GB/GB]; London Square, Cross Lanes, Guildford, Surrey GU1 1UE (GB). (71)(72) Applicant and Inventor (for all designated States except MW): HAILEY, Charles, D. [US/US]; 1661 Exchange Avenue, Oklahoma City, OK 73108 (US). (72) Inventors: BLOUNT, Curtis, G.; 251 Gail Drive, Wasilla, AK 99654 (US). HIGHTOWER, Charles, M.; 641 Post Oak Drive, Plano, TX 75025 (US). (74) Agent: CROPP, John, Anthony, David; Mathys &amp; Squire, 100 Gray's Inn Road, London WC1X 8AL (GB).</p>	<p>(81) Designated States: CA, MW, NO, European patent (AT, BE, CH, DE, DK, ES, FR, GB, GR, IE, IT, LU, MC, NL, PT, SE).  <b>Published</b> <i>With international search report.</i></p>	

(54) Title: METHOD FOR SETTING A WHIPSTOCK IN A WELLBORE

(57) Abstract

A method for setting a whipstock (25) in a wellbore (2) on a packer-anchor (17) which employs a wireline (11) that carries a setting assembly (20, 35) which severs a shear member (24, 33) carried by the setting assembly after the whipstock is set onto the packer-anchor.

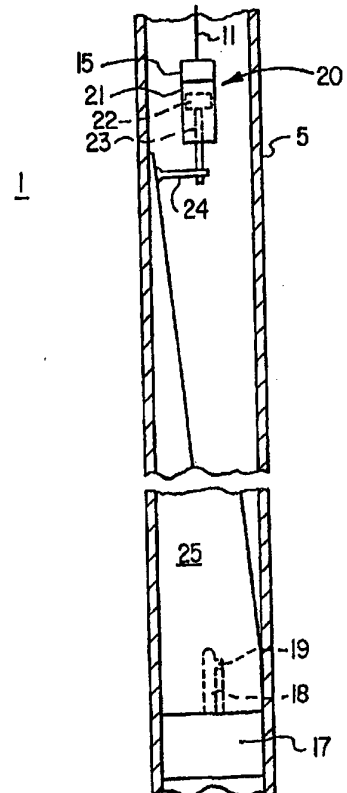

**FOR THE PURPOSES OF INFORMATION ONLY**

Codes used to identify States party to the PCT on the front pages of pamphlets publishing international applications under the PCT.

AT	Austria	GB	United Kingdom	MR	Mauritania
AU	Australia	GE	Georgia	MW	Malawi
BB	Barbados	GN	Guinea	NE	Niger
BE	Belgium	GR	Greece	NL	Netherlands
BF	Burkina Faso	HU	Hungary	NO	Norway
BG	Bulgaria	IE	Ireland	NZ	New Zealand
BJ	Benin	IT	Italy	PL	Poland
BR	Brazil	JP	Japan	PT	Portugal
BY	Belarus	KE	Kenya	RO	Romania
CA	Canada	KG	Kyrgystan	RU	Russian Federation
CF	Central African Republic	KP	Democratic People's Republic of Korea	SD	Sudan
CG	Congo	KR	Republic of Korea	SE	Sweden
CH	Switzerland	KZ	Kazakhstan	SI	Slovenia
CI	Côte d'Ivoire	LI	Liechtenstein	SK	Slovakia
CM	Cameroon	LK	Sri Lanka	SN	Senegal
CN	China	LU	Luxembourg	TD	Chad
CS	Czechoslovakia	LV	Latvia	TG	Togo
CZ	Czech Republic	MC	Monaco	TJ	Tajikistan
DE	Germany	MD	Republic of Moldova	TT	Trinidad and Tobago
DK	Denmark	MG	Madagascar	UA	Ukraine
ES	Spain	ML	Mali	US	United States of America
FI	Finland	MN	Mongolia	UZ	Uzbekistan
FR	France			VN	Viet Nam
GA	Gabon				

METHOD FOR SETTING A WHIPSTOCK IN A WELLBOREBACKGROUND OF THE INVENTION

In subterranean well operations, it is necessary from time to time to set a whipstock in a sub-surface wellbore conduit such as a tubing string or a well casing. The whipstock is set to deviate a mill or a drill bit away from the longitudinal axis of the well conduit. A mill is often used to cut a window in the conduit through which to drill a deviated wellbore at an angle to the longitudinal axis of the conduit and original wellbore.

The whipstock is normally set in the wellbore by the use of a conventional (jointed straight) pipestring or coiled tubing, as fully and completely set forth in U.S. Patent 5,287,921 to Blount, et al.

Setting a whipstock with a pipestring, whether conventional or coiled tubing, takes time and effort, particularly with conventional pipe whose individual lengths have to be connected together at the earth's surface with coupling means.

By this invention, the process of setting a whipstock in a wellbore is substantially speeded by employing a conventional wireline unit.

SUMMARY OF THE INVENTION

In accordance with this invention, a packer-anchor is first set in the wellbore in the vicinity where the whipstock is desired to be located. The wireline is provided with a setting assembly, which assembly carries the whipstock by means which includes a shear member. The setting assembly is passed into the wellbore by means of the wireline on the wireline unit until the whipstock mates with the packer anchor, at which time the setting assembly is actuated to provide an impact force to sever the shear

member and otherwise separating the setting assembly from the whipstock. Thereafter, the wireline and setting assembly is removed from the wellbore, leaving the whipstock set onto the packer anchor.

Accordingly, it is an object of this invention to provide a new and improved method for setting a whipstock in a sub-surface well conduit.

It is another object to provide a new and improved method for employing a conventional electric wireline unit to set a whipstock in a wellbore.

Other aspects, objects and advantages of this invention will be apparent to those skilled in the art from this disclosure and the appended claims.

#### BRIEF DESCRIPTION OF THE DRAWING

Figure 1 shows a conventional electric wireline unit setup for setting a packer anchor in a wellbore.

Figure 2 shows one embodiment of apparatus useful in this invention which employs an electric wireline setting tool.

Figure 3 shows another embodiment of setting assembly apparatus useful in this invention.

Figure 4 shows a cross-section of the setting tool used in the apparatus of Figure 3.

Figure 5 shows yet another embodiment of setting assembly apparatus useful in this invention.

#### DETAILED DESCRIPTION OF A PREFERRED EMBODIMENT

More specifically, Figure 1 shows the earth 1 having a wellbore 2 extending downwardly thereinto. Wellbore 2 is lined with surface casing 3 to a fixed depth 4. Wellbore 2 further contains casing 5 which extends from conventional wellhead 6 at earth's surface 7 down to a producing formation (not shown). Casing 5 extends into wellhead 6 which is surmounted by a conventional crown valve 8. Wellhead 6 carries valved conduit 9 from which

oil, gas or other fluids produced from the producing formation pierced by casing 5 can be removed from the wellbore for treatment, storage, transportation, and the like.

Located on earth's surface 7 adjacent wellhead 6 is a conventional electric wireline unit 10 which carries a supply of electric wireline 11. Wellhead 6 is surmounted by a conventional lubricator 12 which carries a sheave wheel 13 over which wireline 11 passes when it enters lubricator 12 by way of stuffing box grease injector head or 14 for entry into the interior of wellbore 2 and casing 5.

In Figure 1, wireline 11 is shown to be carrying a conventional cable head 15 which simply provides a connecting function for whatever apparatus is to be connected to and carried by wireline 11. Below cable head 15 there is provided a conventional electric wireline setting tool 16. Setting tool 16 carries a whipstock packer or packer-anchor 17. Packer 17 has rigidly fixed thereto upstanding stinger 18, stinger 18 being fixed to setting tool 16 in a conventional manner. Stinger 18 also carries orienting lug 19 for orienting the whipstock in the desired manner when the whipstock is set onto packer 17. Packer 17 can also be set with a single arm bow spring, magnet or similar orientation device plus a surface read out device to tell the operator if lug 19 is in a desirable position.

When packer 17 is lowered to the desired location along the length of casing 5, setting tool 16 is electrically actuated from wireline unit 10 by transmission of an electrical signal along wireline 11 to sever setting tool 16 from stinger 18 in a conventional manner. Setting tool 16 can be any basic wireline setting tool such as a Baker Model E-4 wireline pressure setting device. The anchor can then be checked with a conventional survey tool to determine the orientation of lug 19. The method, as

thus far described, is known to the prior art and need not be described in greater detail to fully inform those skilled in the art.

After packer 17 is set inside casing 5 in the manner described in Figure 1, it is time to set a whipstock onto packer 17. In accordance with one embodiment of this invention, as shown in Figure 2, wireline 11 and cable head 15 are employed to carry an electric wireline setting tool 20 which carries a conventional firing head 21 similar to that used in setting tool 16. Setting tool 20 also carries piston 22 which moves downwardly, in the case of the apparatus of Figure 2, in response to the detonation of explosive carried in firing head 21. The explosive is detonated by means of an electrical signal passed through wireline 11 from electric wireline unit 10 of Figure 1. Piston 22 carries piston rod 23 which is connected directly or indirectly to a shear member 24 or connecting device such as shown in U.S. Patent 5,222,554 to Blount et al. Shear member 24 is rigidly fixed to whipstock 25. Thus, when whipstock 25 is set down onto anchor 17 so that stinger 18 and orienting lug 19 mate with matching apertures and grooves in the interior of whipstock 25, it is time to separate setting tool 20 from whipstock 25. This is done by electrically actuating the explosive in firing head 21 which imparts an impact force to piston 22 which force severs shear member 24 or otherwise releases whipstock 25. Thereafter, wireline 11, cable head 15 and setting tool 20, along with piston 22 and rod 23, can be removed from the interior of casing 5, thereby leaving whipstock 25 set firmly onto packer 17. It should be understood that other tools can be used such as those in which piston 22 does not move but rather the cylinder around the piston or some other member move to effect the desired shearing action.

Figure 3 shows non-electrical apparatus useful in the method of this invention which can be employed by

way of wireline 11 and cable head 15 to set whipstock 25 onto packer 17. The apparatus employed in the embodiment of Figure 3 is setting assembly 35 which is composed of accelerator tool 30, jar tool 31, setting tool 32 and shear member 33.

Accelerator tool 30 is an optional tool which is used between cable head 15 and jar tool 31 to store energy and insulate wireline 11 from the impact force generated by jar tool 31. Accordingly, accelerator tool 30 need not be employed in the apparatus of Figure 3 but is preferred. Accelerator tool 30 is joined by means of conventional coupling 34 to mechanically or hydraulically actuated jar tool 31 which, when actuated by, for example, pulling on wireline 11, triggers the impact force from jar 31 necessary to sever shear member 33. This separates whipstock 25 from setting assembly 35. Setting tool 32 is joined by another conventional coupling 34 to jar 31.

Thus, with the apparatus of Figure 3, whipstock 25 is set down onto anchor 17, as shown in Figure 2, by use of setting assembly 35. Assembly 35 is removed from the interior of casing 5 after jar tool 31 severs shear member 33.

Jar tool 31 is a conventional piece of equipment which is designed, for example, to be actuated in response to a pulling force exerted on wireline 11 by unit 10 when setting assembly 35 is in the location desired in the wellbore. The jarring impact force delivered by jar 31 can be directed either up, down, or both up and down in assembly 35. Any commercially available mechanically or hydraulically actuated jar tool can be employed in this invention.

Accelerator tool 30 is also a conventional piece of apparatus currently available to those skilled in the art. It serves as an energy storage device to maximize the effectiveness of jar tool 31 and as a shock absorber to insulate wireline 11 from shock loads that may be

encountered when jar tool 31 is actuated to release the whipstock and sever shear member 33. Any commercially available accelerator tool well known to those skilled in the art can be employed in this invention.

Figure 4 shows a bottom view of setting tool 32. Setting tool 32 is essentially round in configuration, as are the other tools shown in setting assemblies 20 and 35 of Figures 2 and 3, and has a flat bottom portion 40 from which extends hemispherical section 41. Shear member 33 passes through and is rigidly fixed to section 41 and has an opposing shank end 42 which is threaded for engaging with a matching threaded aperture in whipstock 25. Enlarged portion 43 can be provided so as to leave a projection on the guide face 44 (Figure 3) of whipstock 25 after shear member 33 is severed. Projection 43 can then provide the function of a wear pad or wear lug for guiding a starting mill as fully described in the aforesaid U.S. Patent 5,287,921.

Figure 5 shows setting assembly 35 with the modification that weight bar 50 is imposed between accelerator 30 and jar 31 and connected to both by means of conventional couplings 34. Weight bar 50 is optional in this invention but provides the useful function, when desired, of accentuating the impact force of jar 31 when it is actuated by wireline unit 10, thus increasing the jarring impact of jar 30 on shear member 33.

Optionally, a conventional orienting tool 51 can be carried by the setting assembly 35 of Figure 5 or setting assembly 20 of Figure 2. The orienting tool is used to tell the operator at the earth's surface the orientation of the whipstock while it is being set in place on packer 17.

A conventional indexing tool 52 can also be carried by setting assembly 35 or 20. This tool is used to physically rotate the whipstock and orient it in the desired direction before it is set onto packer 17. Tool 52



is also optional.

The apparatus of this invention can be employed inside any well conduit in a wellbore and can be run through tubing that is already in place inside casing such as casing 5. In the case of through tubing operations the tubing can end intermediate the length of the casing so that the anchor packer and whipstock can be passed through the tubing and then set inside the casing below where the tubing ends.

Reasonable variations and modifications are possible within the scope of this disclosure without departing from the spirit and scope of this invention.

What is claimed is:

CLAIMS

1. In a method for setting a whipstock in a wellbore that extends into the earth from the earth's surface wherein a packer-anchor is first set in said wellbore and said whipstock is thereafter set onto said packer anchor, the improvement comprising providing a wireline unit at the earth's surface having a supply of wireline, said wireline carrying at a first end a setting assembly, said setting assembly carrying a shear member, said shear member being connected to said whipstock, passing said first end of said wireline with said setting assembly-whipstock combination into said wellbore until said whipstock mates with said packer-anchor, actuating said setting assembly to provide an impact force to sever said shear member, and removing said wireline and setting assembly from said wellbore thereby leaving said whipstock set onto said packer anchor.

2. The method set forth in Claim 1 wherein:  
said setting assembly is electrically actuated and is composed of an electric wireline setting tool that carries a firing head containing an explosive that is electrically actuated and a member that moves in response to actuation of said explosive, said member acting upon said shear member.

3. The method set forth in Claim 1 wherein:  
said setting assembly is composed of a jar tool.

4. The method set forth in Claim 3 wherein:  
said wireline carries an accelerator tool between said first end and said jar tool to store energy and insulate said wireline from the impact force generated by said jar tool.

5. The method set forth in Claim 3 wherein:  
said wireline carries at least one weight  
bar adjacent said jar tool to accentuate the jarring impact  
of said jar tool.

6. The method set forth in Claim 1 wherein:  
said setting assembly carries at least one  
of an orienting tool and an indexing tool.

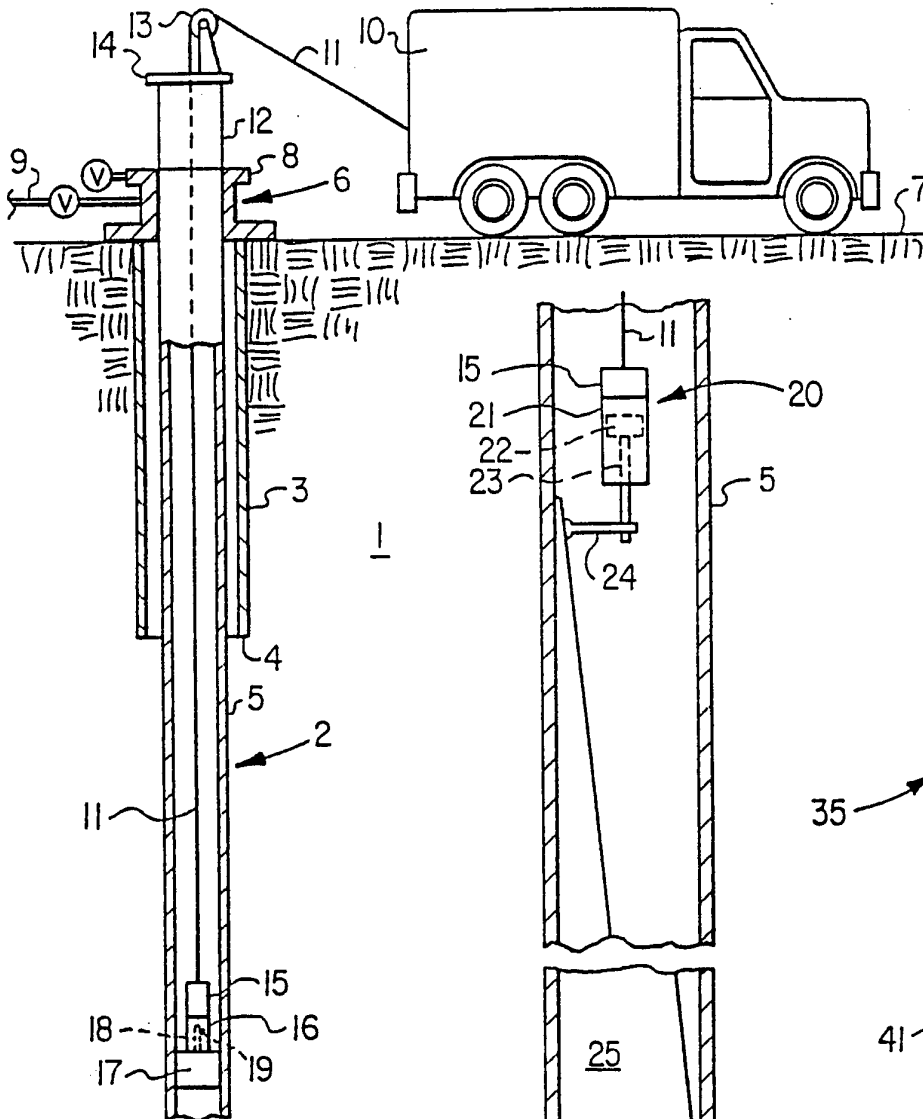

FIG. 1

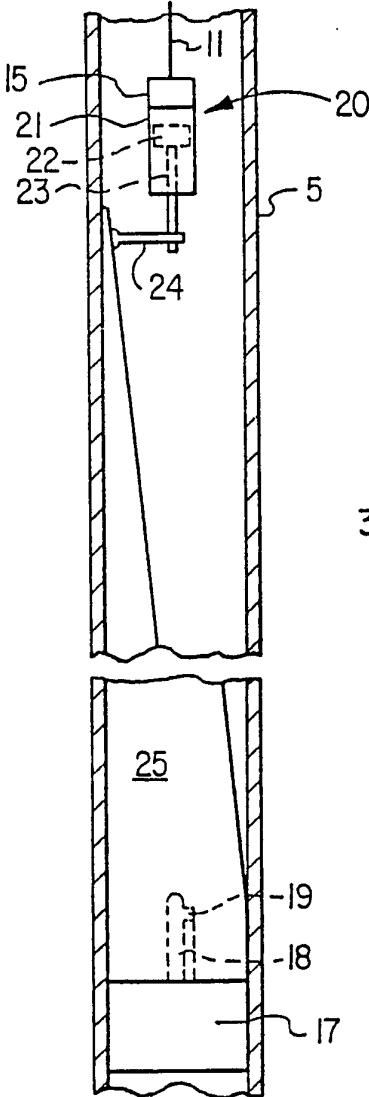

FIG. 2

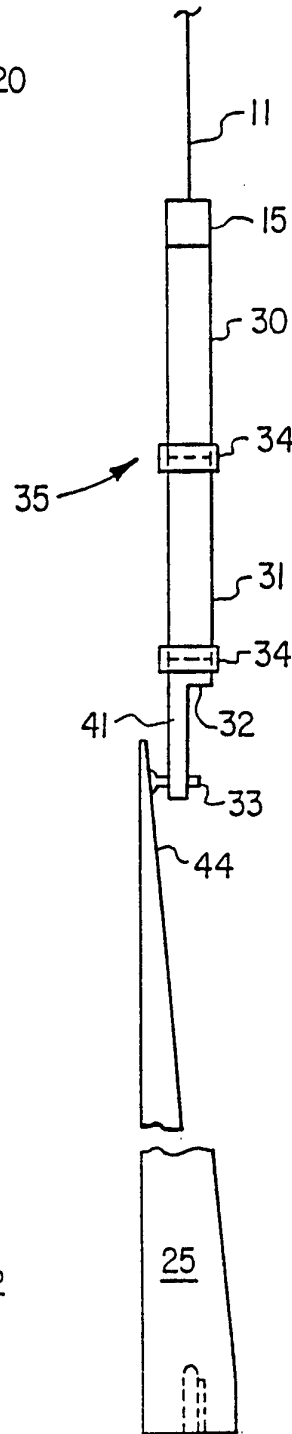

FIG. 3

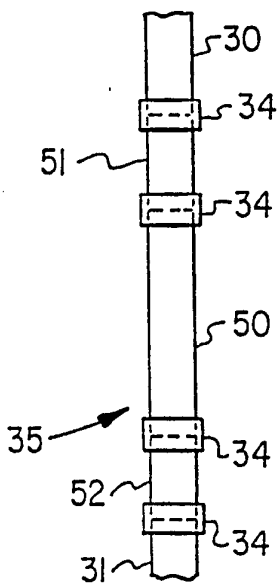

FIG. 5

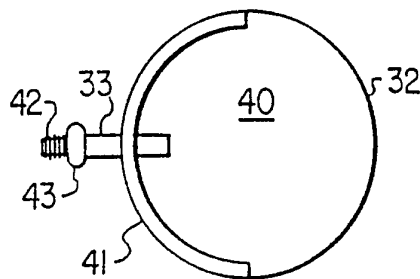

FIG. 4

INTERNATIONAL SEARCH REPORT

International Application No  
PCT/GB 95/01196

A. CLASSIFICATION OF SUBJECT MATTER  
IPC 6 E21B23/00 E21B7/06

According to International Patent Classification (IPC) or to both national classification and IPC

B. FIELDS SEARCHED

Minimum documentation searched (classification system followed by classification symbols)  
IPC 6 E21B

Documentation searched other than minimum documentation to the extent that such documents are included in the fields searched

Electronic data base consulted during the international search (name of data base and, where practical, search terms used)

C. DOCUMENTS CONSIDERED TO BE RELEVANT

Category *	Citation of document, with indication, where appropriate, of the relevant passages	Relevant to claim No.
X	US,A,5 287 921 (BLOUNT) 22 February 1994 cited in the application see column 4, line 52 - line 65 see column 5, line 46 - line 67 see column 6, line 7 - line 35 see column 8, line 25 - line 28 ---	1,3-6
A	US,A,5 222 554 (BLOUNT) 29 June 1993 cited in the application see column 3, line 14 - line 30 ---	1,2
A	US,A,2 707 999 (RAGAN) 10 May 1955 see column 3, line 3 - line 8 ---	1,2
A	US,A,1 951 638 (WALKER) 20 March 1934 see claim 2 -----	1,2

Further documents are listed in the continuation of box C.  Patent family members are listed in annex.

\* Special categories of cited documents :

"A" document defining the general state of the art which is not considered to be of particular relevance

"E" earlier document but published on or after the international filing date

"L" document which may throw doubts on priority claim(s) or which is cited to establish the publication date of another citation or other special reason (as specified)

"O" document referring to an oral disclosure, use, exhibition or other means

"P" document published prior to the international filing date but later than the priority date claimed

"T" later document published after the international filing date or priority date and not in conflict with the application but cited to understand the principle or theory underlying the invention

"X" document of particular relevance; the claimed invention cannot be considered novel or cannot be considered to involve an inventive step when the document is taken alone

"Y" document of particular relevance; the claimed invention cannot be considered to involve an inventive step when the document is combined with one or more other such documents, such combination being obvious to a person skilled in the art.

"&" document member of the same patent family

Date of the actual completion of the international search  
12 September 1995

Date of mailing of the international search report  
22.09.95

Name and mailing address of the ISA  
European Patent Office, P.B. 5818 Patentlaan 2  
NL - 2280 HV Rijswijk  
Tel. (+ 31-70) 340-2040, Tx. 31 651 epo nl,  
Fax: (+ 31-70) 340-3016

Authorized officer  
Sogno, M

## INTERNATIONAL SEARCH REPORT

Information on patent family members

International Application No

PCT/GB 95/01196

Patent document cited in search report	Publication date	Patent family member(s)	Publication date
US-A-5287921	22-02-94	WO-A- 9416190	21-07-94
US-A-5222554	29-06-93	CA-A- 2126553 EP-A- 0623187 NO-A- 942820 WO-A- 9315301	05-08-93 09-11-94 29-07-94 05-08-93
US-A-2707999	10-05-55	NONE	
US-A-1951638	20-03-34	NONE	