

(12) PATENT
(19) AUSTRALIAN PATENT OFFICE

(11) Application No. AU 200214701 B2
(10) Patent No. 781900

(54) Title
Step up converter in an architectural covering device

(51) ⁶ International Patent Classification(s)
H02M 007/30 H02P 009/08

(21) Application No: 200214701 (22) Application Date: 2002.01.30

(30) Priority Data

(31) Number	(32) Date	(33) Country
01300816	2001.01.30	EP

(43) Publication Date : 2002.08.01
(43) Publication Journal Date : 2002.08.01
(44) Accepted Journal Date : 2005.06.23

(71) Applicant(s)
Turnils A.B.

(72) Inventor(s)
Anne J. Osinga; Jochem Welvaadt

(74) Agent/Attorney
Shelston IP,Level 21,60 Margaret Street,SYDNEY NSW 2000

(56) Related Art
WO 1999/031780

ABSTRACT

The invention relates to a drive assembly (45, 46, 52) for a covering of an architectural opening, comprising a motor drive (52), an accumulator (54) connected to the motor drive, a power source (45) and an electrical circuit (55) connecting the power source to the accumulator. The electrical circuit comprises a step-up converter. Preferably, the step-up converter comprises an input terminal (11) connected to the power source (45), and an output terminal (12) with a supply voltage, connected to the accumulator (54), the voltage converting circuit (2) having:

- an input terminal (11) for connection to a varying voltage or current source, and an output terminal (12) with a supply voltage,
- an inductive element (5) being with a first terminal connected to the input terminal and with a second terminal to a capacitive element (8) and to the output terminal (12), the capacitive element (8) being with one terminal connected to a reference voltage (9),
- a first switch (6) being with a first terminal connected to the second terminal of the inductive element (5), and with a second terminal to the reference voltage (9), the first switch (6) comprising a gate electrode (31) for opening and closing of the switch when a control voltage of a first level is applied to the gate,
- an oscillator (13) comprising a power input (14) connected to the output terminal (12), a start-up output (15) connected to the gate electrode (31) of the first switch (6) for supplying a pulse-like signal to the gate electrode (31) and an oscillator output (16).

AUSTRALIA

PATENTS ACT 1990

COMPLETE SPECIFICATION

FOR A STANDARD PATENT

ORIGINAL

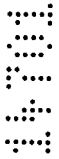

Name of Applicant: Turnils A.B.

Actual Inventors: Anne J. Osinga and Jochem Welvaadt

Address for Service: BALDWIN SHELSTON WATERS
60 MARGARET STREET
SYDNEY NSW 2000

CCN: 3710000352

Invention Title: 'STEP UP CONVERTER IN AN ARCHITECTURAL COVERING
DEVICE'



The following statement is a full description of this invention, including the best method of performing it known to us:-

File: 34416AUP00

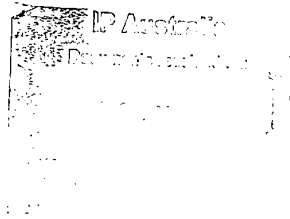

The invention relates to a drive assembly for a covering of an architectural opening, comprising a motor drive, an accumulator connected to the motor drive, a power source and an electrical circuit connecting the power source to the accumulator.

Any discussion of the prior art throughout the specification should in no way be considered as an admission that such prior art is widely known or forms part of common general knowledge in the field.

Light regulating devices, such as retractable and extendable awnings and control systems for automatically extending such awnings are known.

Motor driven venetian blinds comprising either vertical or horizontal slats are known, which can be opened by retracting the slats to one side of the window and in which the position of the slats around their longitudinal axis can be controlled electrically via a control unit, which blinds are powered from the mains power supply.

It is an object of the present invention to overcome or ameliorate at least one of the disadvantages of the prior art, or to provide a useful alternative.

Thereto, the drive assembly according to the present invention is characterized in that the electrical circuit comprises a step-up converter.

The step-up converter transforms the small fluctuating voltage or current derived from the power source to DC current ranging from 1-20 V, suitable for charging the accumulator for operating the motor drive. Use of the step-up converter allows the drive assembly to be powered by a solar cell of small dimensions, which may be mounted for instance at the inside of a window on the head rail of a venetian blind, facing towards the inside of the building, or being placed on any position on the windowsill.

According to one aspect, the present provides a power supply for an electrically operated architectural covering device, the power supply including:

a voltage or current source having a varying voltage output; an electrical device; and

a voltage converting unit electrically coupling the voltage or current source to the electrical device,

wherein the voltage converting unit includes a step-up converter, the step-up converter having an inductive element, and

wherein the voltage or current source is the sole supply of power to the voltage converting circuit, which thereby is self-starting from a situation of rest.

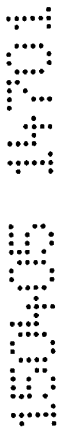

In an embodiment of the power supply according to the present invention the voltage or current source is a solar cell generating a voltage of less than 0.5 V; and the voltage converting unit further includes a low voltage converting circuit having:

- 5 an input terminal connected to the voltage or current source for receiving a varying voltage or current therefrom;
- an output terminal for supplying voltage to the electrical device;
- an inductive element having an input terminal connected to the voltage or current source via the input and having an output terminal connected to the output;
- 10 a capacitive element having one terminal connected to the output terminal of the inductive element and having its other terminal connected to a reference voltage line;
- a first switch connected between the inductive element and the reference voltage line, the first switch comprising a gate electrode for operating the first switch in response to a first voltage level control signal; and
- 15 an oscillator for generating a first pulsed signal, the oscillator having a power input connected to the output terminal and a start-up output for a first voltage level connected to the gate electrode of the first switch.

The energy from the voltage or current source is stored in the inductive element and is periodically charging the capacitor for forming and increasing supply voltage on the output terminal. This increasing supply voltage is fed into the oscillator, which output signal rises as a consequence resulting in better control of the switch and hence more power being input into the capacitive element, such that the voltage of the output terminal is increased.

In a preferred embodiment, the low voltage converting unit further comprises a second switch connected in parallel with the first switch, the second switch having a gate electrode connected to the oscillator output, wherein the first switch remains opened when the supply voltage at the output terminal reaches a predetermined level, and the second switch is operated by the oscillator output at a second voltage level that is higher than the first voltage level.

30 The varying input voltage is fed into the inductive element, which is periodically connected to reference voltage by opening of the first switch under control of the start-



up output of the oscillator. The power input of the oscillator is connected to the supply voltage terminal, which at start-up receives a very small voltage. The resulting start-up output voltage is correspondingly small, for instance 0.2 V or less. When the first switch is opened and closed again, a rising current is generated in the inductive element, which charges the capacitive element such that the supply voltage is successively increased. The first switch is particularly suited to be operated at a low gate control voltage from the start-up output of the oscillator. As the supply voltage increases, the start-up output signal of the oscillator will increase, resulting in better operation of the first switch and more power being transferred from the inductive element to the capacitive element, such that a self-amplifying effect results in increasing the supply voltage and the oscillator start-up output signal. When the supply voltage reaches a predetermined value, the first switch is de-activated (opened) and the second switch is operated from a second oscillator output, at a gate control voltage, which is above the gate control voltage of the first switch. Operation of the second switch results in a further increase in the supply voltage. The first switch may for instance be formed by a bipolar pnp- transistor with a gate control voltage of 0.6V above reference voltage, a collector-emitter voltage V_{ce} of 600 mV at a collector current I_c of 100 mA. The second switch may be formed by a low power logic level MOSFET with a gate control voltage V_{gs} (gate threshold voltage) generally in the range of 1-2V at a source voltage V_{ds} of 2V and at a current I_{ds} of 0.3-1.2A.

By the use of the two switches according to the present invention, each operating at a different gate control voltage level, a self-starting step-up converter is achieved.

In one embodiment, a diode is connected between the second terminal of the inductive element at the gate electrode of the first switch. When a varying supply voltage of about 0.4V is offered to the input terminal, and the supply voltage is about 0.4V, a 0.4V bias voltage on the control terminal of the first switch is maintained by the positive clamp formed by the diode. Hence, in case the first switch is formed by a pnp bipolar transistor, only a 0.2V varying control voltage is necessary at the gate to bring the transistor into conduction. The 0.2V varying voltage is obtained from the oscillator when powered at its input by a 0.4V supply voltage level.

In a further embodiment, the outputs of the oscillator are connected to the gates via respective capacitive elements. By the capacitive element coupling, the small DC

control voltage from the start-up output of the oscillator is added to the 0.4VDC level of the diode clamp.

5 A voltage converting unit may be formed by attaching a second converting stage to the voltage converting circuit, the second converting stage having an inductive element with a first terminal connectable to the varying voltage source, and connected with a second terminal to a first terminal of an electrical element such as an accumulator, the accumulator being with a second terminal connected to the reference voltage, a third switch being connected between the second terminal of the inductive element and the reference voltage and being with a gate electrode connected to an oscillator output of a second oscillator, the supply voltage of the output terminal of the voltage converting circuit being connected to the second terminal of the inductive element and to a power input of the second oscillator. The third switch may be formed by a power MOSFET having multiple drains and multiple sources for further converting the DC-voltage from the converting circuit to levels of between 3-15V.

10
15 The voltage converting circuit according to the present invention may be applied in combination with a solar cell as a power source, a fuel cell or other varying voltage or current sources having relatively small current and voltages at their output. The voltage-converting unit according to the present invention may be part of a cattle watering unit, country road lighting or an electrical fence in the countryside when as a voltage source a solar cell is used. Other applications in combination with a solar cell are digital billboards, billboard lighting, street lighting or information points.

20
25 Furthermore, the device of the present invention can be used to power speed control devices along roads, roadside reflectors or road markings (cat eyes), emergency points etc.

Alternatively, the voltage converting circuit can be applied in marine applications as a generator on boats, for boat lighting, as a navigation device or a GPS-system.

Mobile phones, laptops, organisers, and other appliances may be powered by the voltage converting circuit which only needs a very small voltage input.

30 Furthermore, digital cameras, battery chargers, bicycle lighting, danger triangles, avalanche beepers, flashlight, tv's, microwaves and other domestic appliances, garden lighting, garden sprayers and light regulating devices for windows, such as window blinds, awnings and etc. may be powered by the voltage converting circuit of the present invention.

According to a further aspect, the present invention provides an electrically operated architectural covering device, including:

a first rail;

a covering member extending from the first rail;

5 an electric motor for opening and closing the architectural covering device; at least one photovoltaic cell;

a rechargeable power source;

a first circuit electrically coupling at least one photovoltaic cell to the rechargeable power source; and

10 a second circuit electrically coupling the electric motor to the rechargeable power source, wherein the first circuit includes a step-up converter, the step-up converter having an inductive element. and

wherein the electric motor is mounted to the first rail.

The invention is most beneficial to small sized appliances by allowing a
15 substantial reduction in surface of the solar cells.

Unless the context clearly requires otherwise, throughout the description and the claims, the words 'comprise', 'comprising', and the like are to be construed in an inclusive sense as opposed to an exclusive or exhaustive sense; that is to say, in the sense of "including, but not limited to".

20 Some embodiments of a voltage-converting unit according to the present invention will be explained in detail with reference to the accompanying drawings. In the drawings:

Fig. 1 shows an architectural covering device according to the present invention comprising a pleated light regulating device;

25 Fig. 2 shows an architectural covering device according to the present invention comprising a venetian blind;

Fig. 3 shows schematically the drive assembly according to the present invention;

30 Fig. 4 schematically shows an assembly of a voltage converting circuit according to the present invention in combination with a DC-DC step-up voltage converter connected to an electrical device;

Fig. 5 shows in detail the components of the voltage converting circuit and DC-DC converter of Fig. 1;



Fig. 6 shows an alternative embodiment of a voltage converting circuit according to the present invention wherein the second switch is controlled by a microprocessor;

Fig. 7 shows a schematic diagram of the input and output voltages of the inverters U_{1C} and U_{1E} ;

5 Fig. 8 shows an input voltage of inverter U_{1C} during start-up; and

Fig. 9 shows an output voltage of inverter U_{1C} during start-up.

Fig. 1 shows a wall 40 having a window 41 along the upper end of which a head rail 42 of a pleated window covering 43 is mounted. On the head rail a drive assembly 44 is mounted comprising an array of photovoltaic cells (solar cells) 45 facing towards the interior of the wall 40, an electric drive assembly 46 comprising a drive motor, an accumulator and a step-up converter connecting the accumulator to the solar cells 45. The assembly 46 can be completely integrated into the head rail 42 or can be provided as

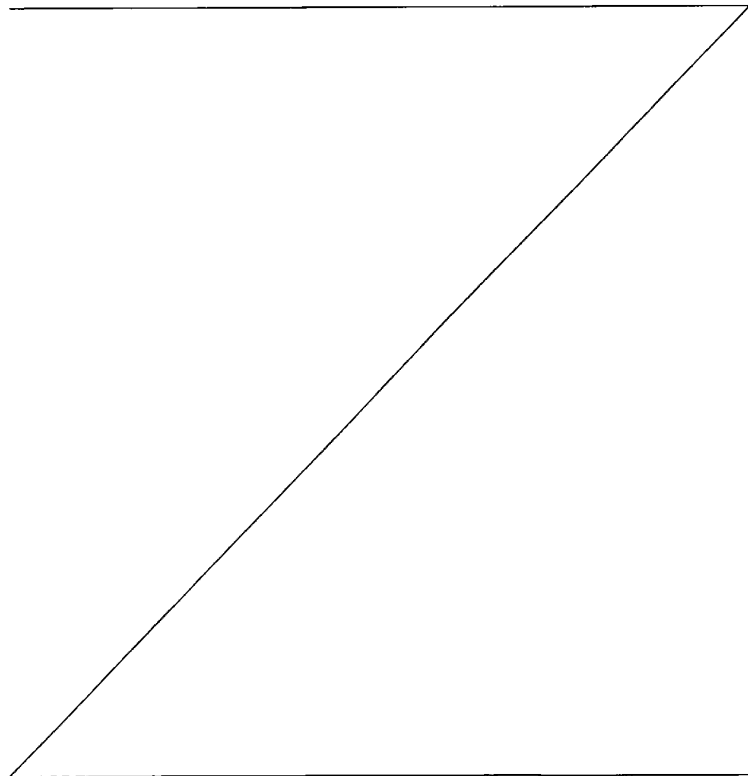

5
10

a separate unit attached to the wall 40. Control unit 48 for raising or lowering the window covering 43 is connected to the drive assembly 46.

Fig. 2 shows an alternative embodiment of a winder covering comprising a vertically deploying venetian blind, having horizontal slats 50 suspended from a head rail 42. Solar cells 45 are mounted on a windowsill and connected through electrical leads 51 to drive assembly 46. By operation of the control unit 48 the slats 50 may be raised or lowered or may be changed in orientation by rotating around their longitudinal axes.

Fig. 3 schematically shows a drive assembly according to the present invention, comprising an electric motor 52 for raising or lowering the window covering and/or changing the orientation of the slats 50, an electrical circuit 53, an accumulator or battery 54, a step-up converter 55 and a photovoltaic cell 45. The electrical circuit 53 may comprise a step-up converter for increasing the voltage derived from the battery 54. The battery 54 may comprise a metal hydride accumulator, an alkaline manganese battery, a lithium ion battery, or a plurality of lithium ion batteries in series.

In an embodiment, the accumulator has a capacity not exceeding 1.4 Ah. The battery may be a 3.6 V battery system, whereas the electric motor 52 may operate at 12 V DC as the power requirement not exceeding 50 mWh per day.

In a preferred embodiment the active operation of the electric motor 52 does not exceed 40 s per day.

Fig. 4 shows a step-up voltage converting unit 1 having a voltage converting circuit, or low voltage converter stage 2, connected to a second converter stage 3. The low voltage converter stage 2 comprises an input terminal 4, an inductive element 5, first and second switches 6, 7 and a capacitive element such as capacitor 8. Switches 6 and 7 are with a first terminal connected to the inductive element 5 and with a second terminal to a reference voltage line 9. The second terminal of capacitive element 8 is connected to the output of a diode 11 and to the supply voltage terminal 12. The supply voltage terminal 12 is connected to a power input 14 of a first oscillator 13. A start-up output 15 of the first oscillator 13 is connected to the base or gate electrode 31 of switch 6 whereas the oscillator output 16 is connected to the gate electrode 32 of switch 7. The supply voltage an output terminal 12 of low voltage converter stage 2 is connected to the second terminal of inductive element 28 and to a power input 22 of second oscillator 17 of second converter stage 3. The oscillator output 18 connects to the gate electrode 33 of



switch 19. A diode 20 and capacitive element or capacitor 21 are connected between the inductive element 28 and reference voltage line 23. Electrical device 24 is connected across output terminals 25, 26 of second converter stage 3.

When at start-up a varying low voltage supply, such as a solar cell, is connected to input terminals 4 and 27 of the voltage converter unit 1, and switches 6, 7 are closed, the capacitive element 8 is charged, creating a small voltage on the output terminal 12 and on first oscillator power input 14. The small power input into the oscillator 13, results in a pulse shaped signal on start-up output 15 at a low gate control voltage level V_{c1} , which may be a few tenths of Volts, periodically opening and closing the switch 6 at the frequency of for instance 100 kHz. This causes a periodic current through the switch 6 resulting in a rising current through the inductive element 5, charging capacitor 8 that is rectified by diode 11 and results in an increasing voltage at the supply voltage terminal 12 and consequently at the power input 14 of the first oscillator 13. This effect continues until the voltage level at supply terminal 12 reaches a predetermined level, after which low voltage controlled switch 6 is de-activated (opened) and high voltage controlled switch 7 is operated from oscillator output 16. The second switch 7 is operated at a control voltage level V_{c2} until the supply voltage at supply voltage terminal 12 is for instance a few volts. The supply voltage is input into second converter stage 3 at the second terminal of inductive element 28 and into power input 22 of second oscillator 17. At oscillator output 18, a pulsed control signal operating the gate electrode 33 of switch 19 is generated. By switching on and off the switch 19, the energy stored in inductive element 28 is transferred to capacitor 21 until a predetermined voltage level is reached. At this predetermined level, such as voltage levels between 1.5-12V, switch 19 is opened such that electrical energy is stored in inductive element 28, to be released again upon closing of the switch 19.

As the step-up voltage-converting unit 1 generates its own supply voltage from a situation of rest, the step-up converter is self-starting.

Fig. 5 shows in detail the components of the voltage converter stage 2 and second converter stage 3 according to the present invention. The following letter symbols apply:

- T_1 : low power, logic level MOSFET;
- T_2 : switching MOSFET; power MOSFET;
- L_1 : switching coil with high inductance;

- L₄ : switching coil;
- D₁, D₂ : rectifying diodes;
- C₉, C₂₁, C₁ : smoothening electrically controllable capacitors (elco's);
- U_{1A}-U_{1F}; U_{1C} : low voltage inverter gates manufactured by Philips
5 Electronics under type number 74HC14;
- T₄ : switching bipolar transistors;
- D₂, D₄ : Schottky diodes;
- C₃ : relatively small capacitor.

The second converter stage 3 operates according to known DC-DC voltage
10 converter principles according to which the small fluctuating voltage V-solar at the input
of coil 28 is stored in the coil when switching MOSFET 19 is opened. Upon closing of
the switching MOSFET 19, the energy is released from the coil 28 and supplied via
rectifier diode 20 to smoothening capacitors 21 resulting in an increased voltage across
output terminals 25, 26. In order to be self-starting, voltage converter circuit or step-up
15 circuit 2 is provided wherein the oscillator 13 is constructed of active component of the
type of Philips low voltage inverter ports or gates U_{1C} and U_{1E}. The inverter ports can
generate at their output, voltages at an input voltage of V_{cc} of below 0.4V at start-up.

At low supply voltages V_{cc}, transistors T₃ is switched-off and a very low
alternating voltage is supplied via start-up output 15 of oscillator 13 to a coupling
20 capacitor C₂ and from thereon to the base 31 of transistors T₄, Schottky diode D₄ is used
as a positive clamp such that a small alternating voltage appears on the base 31 with an
offset of 0.4V. The solar cell voltage is about 0.4V. The transistor T₄ will go in
conduction at a gate voltage of about 0.6V, such that the gate voltage need only be 0.2V
in order to get transistor T₄ into conduction. It has appeared that the oscillating inverter
25 gate U_{1C} of oscillator 13 can supply enough energy to get the transistor T₄ into
conduction. This causes a periodic current in the collector c of transistor T₄. Since the
transistor T₄ is coupled with a switching coil with a relatively high inductance L₁ and a
relatively small capacitor C₃, the periodic current in the collector c results in an AC-
voltage across the coil 5. This AC-voltage is rectified through Schottky diode D₂ and
30 appears on supply voltage terminal 12 and is fed back at the supply of low voltage
inverter gates U_{1C}-U_{1F}. Each time V_{cc} rises, the voltage level at the start-up output 15
of the oscillator 13 rises, resulting in better control of switching transistor T₄. Proper
gating of transistor T₄ results in more power being stored in coil 5, increasing supply



terminal voltage V_{cc} etc. At the outlet 30 of the oscillator U_{1C} , a coupling capacitor C_4 is provided which operates a low voltage inverter gate U_{1E} . The output of the oscillator U_{1E} is connected to the control gate 32 of a low power logic level of the MOSFET T_1 . The coupling capacitor C_4 ensures that the MOSFET of T_1 switches at the beginning or start-up in phase with transistor T_4 .

When the supply voltage V_{cc} rises above the threshold level of logic level MOSFET T_1 , transistor T_3 goes into conduction, pulling the input of oscillator U_{1C} to ground such that first transistor T_4 is switched-off and logic level MOSFET T_1 takes over. Now V_{cc} can rise to for instance 3 V wherein the final power conversion up to voltages ranging from 1.5-12.0 V is effected by power MOSFET T_2 of second converter stage 3. When V_{cc} reaches its desired end level, the varying supply level V_{solar} will place transistor T_5 in conduction pulling the input of oscillator U_{1F} to ground and deactivating switch T_2 .

Fig. 6 shows another embodiment of a low voltage solar converter including a step-up DC-DC converter (sometimes also called: a voltage increasing chopper). The main components of the step-up converter are:

inductor/inductance L_4 ; semiconductor switch T_4 and supplemental N-channel MOSFET T_2 ; diode D_1 (Schottky ZHCS 750) and capacitor/capacitance in the form of high capacity elco C_{23} compensated for low resistance by additional capacitors C_{19} and C_{20} .

Semiconductor switch T_4 operates the step-up converter at those times when the voltage is too low to operate the MOSFET switch T_2 . Switch T_4 is operated by an oscillator circuit as indicated in Fig. 3 by a dash-dotted box. The output of the oscillator connects to the start-up oscillator connector of the step-up converter where Schottky diode D_3 (ZHCS 750) adds the output voltage of the solar panel 425a to the pulsed voltage generated by the oscillator. The resulting voltage is offered to the base of T_4 . As soon as the voltage offered to the step-up converter is high enough for the MOSFET switch T_2 to operate, the oscillator output is grounded through semiconductor T_3 of the oscillator circuit. Then the MOSFET T_2 is controlled from the "N-gate" output of the central micro processor 471 and a further P-channel MOSFET T_1 is controlled from the "P-gate" output of the processor 471 to take over from the Schottky diode D_1 . The P and N-gates of the processor 471 are software driven. In this manner a particularly advantageous step-up converter has been obtained. The alternative use of semiconductor switches T_4 and T_2 provides for a register of compound step-up converter that has



optimal characteristics for each of a low voltage and a higher voltage range. The provision of Schottky diode D_3 enables to offer an as high as possible voltage to the base of the low voltage semiconductor switch T_4 . The additional MOSFET switch T_1 , which is positioned in parallel to diode D_1 , allows to eliminate the losses, which normally occur
5 in diodes such as D_1 .

Fig. 7 shows the input and output voltages V_1 , V_0 of inverter ports U_{1C} and $1E$, which are inverting Schmitt-trigger inverter ports. Generally, at a supply voltage V_{cc} of 1V, the negative-going threshold V_{T1} will be about 0.5V, the positive-going threshold V_{T2} being several tenths of Volts higher. The output voltage V_0 will be limited to a
10 maximum of supply voltage V_{cc} . The inventors have found out that at supply voltages V_{cc} below specification of the manufacturer, there still is a hysteresis in the output signal such that an oscillator can be obtained by feedback of the output signal to the input via resistor R_2 . At a supply voltage of V_{cc} 0.4V the input at the inverter gate U_{1C} is given in Fig. 8, at a level of about 300 mV, at a frequency of about 4kHz.

15 In Fig. 9, the output at inverter gate U_{1C} is given at a level of 400 mV with a frequency of about 20 kHz. Surprisingly, at low supply voltages V_{cc} and at low input levels below the negative-going threshold V_{T1} according to specifications, it is still possible to obtain an oscillator using inverter gate U_{1C} such that start-up of the step-up converter can be obtained by use of said component.

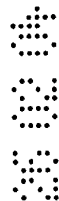

THE CLAIMS DEFINING THE INVENTION ARE AS FOLLOWS:-

1. A power supply for an electrically operated architectural covering device, the power supply including:

a voltage or current source having a varying voltage output; an electrical device; and
a voltage converting unit electrically coupling the voltage or current source to the electrical device,

wherein the voltage converting unit includes a step-up converter, the step-up converter having an inductive element, and

wherein the voltage or current source is the sole supply of power to the voltage converting circuit, which thereby is self-starting from a situation of rest.

2. The power supply for an architectural covering device according to claim 1, wherein the voltage or current source is a solar cell generating a voltage of less than 0.5 V.

3. The power supply for an architectural covering device according to claim 1 or 2, wherein the electrical device is a battery.

4. The power supply for an architectural covering device according to claim 1, wherein the voltage or current source is a solar cell generating a voltage of less than 0.5 V; and

wherein the voltage converting unit further includes a low voltage converting circuit having:

an input terminal connected to the voltage or current source for receiving a varying voltage or current therefrom;

an output terminal for supplying voltage to the electrical device;

an inductive element having an input terminal connected to the voltage or current source via the input and having an output terminal connected to the output;

a capacitive element having one terminal connected to the output terminal of the inductive element and having its other terminal connected to a reference voltage line;

a first switch connected between the inductive element and the reference voltage line, the first switch comprising a gate electrode for operating the first switch in response to a first voltage level control signal; and

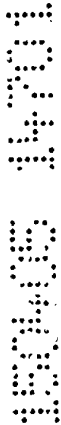

an oscillator for generating a first pulsed signal, the oscillator having a power input connected to the output terminal and a start-up output for a first voltage level connected to the gate electrode of the first switch.

5. The power supply for an architectural covering device according to claim 4, wherein the oscillator comprises an oscillator output for a second voltage level, wherein the low voltage converting circuit further comprises a second switch connected in parallel with the first switch, the second switch having a gate electrode for receiving a second voltage level control signal, the gate electrode of the second switch being connected to the oscillator output, wherein the first switch remains opened when the supply voltage at the output terminal reaches a predetermined level and wherein the second switch is operated by a second pulsed signal from the oscillator output at a second voltage level that is higher than the first voltage level.

6. The power supply for an architectural covering device according to claim 4 or 5, wherein the reference voltage line is grounded.

7. The power supply for an architectural covering device according to claim 5 or 6, wherein the first switch includes a bipolar transistor and the second switch includes a Field Effect Transistor.

8. The power supply for an architectural covering device according to any one of claims 4 to 7, wherein a diode is connected between the output terminal of the inductive element and the gate electrode of the first switch.



9. The power supply for an architectural covering device according to any one of claims 4 to 8, wherein the start-up output of the oscillator is connected to the gate via a respective capacitor.



10. The power supply for an architectural covering device according to any one of claims 4 to 9 wherein the electrical device is a battery.

11. The power supply for an architectural covering device according to claim 10, wherein the voltage converting unit further includes a second converter stage comprising a second

inductive element having a first input terminal connected to the voltage or current source and a second terminal connected to the electrical device, the electrical device with an opposite terminal is connected to the reference voltage line, a third switch being connected between the second terminal of the inductive element and the reference voltage line, the third switch being provided with a gate electrode connected to an oscillator output of a second oscillator, having a power input connected the second terminal of the inductive element and the output terminal of the low voltage converting circuit also being connected to the second terminal of the inductive element.

12. The power supply for an architectural covering device according to claim 11, wherein the third switch comprises a MOSFET semiconductor.

13. The power supply for an architectural covering device according to claim 12, wherein the MOSFET semiconductor has multiple drains and multiple sources.

14. The power supply for an architectural covering device according to any one of claims 11 to 13, wherein the second inductive element has its second terminal connected to the electrical device via a diode and a capacitive element being connected in parallel to the electrical device.

15. Electrically operated architectural covering device, including: a first rail;
a covering member extending from the first rail;
an electric motor for opening and closing the architectural covering device; at least one photovoltaic cell;
a rechargeable power source;
a first circuit electrically coupling at least one photovoltaic cell to the rechargeable power source; and
a second circuit electrically coupling the electric motor to the rechargeable power source, wherein the first circuit includes a step-up converter, the step-up converter having an inductive element. and
wherein the electric motor is mounted to the first rail.

16. Electrically operated architectural covering device according to claim 15, wherein the step-up converter is associated with an oscillator circuit for generating a pulsed voltage to which

the output voltage of the solar cell is added by means of a Schottky diode, before it is offered to a base of the semiconductor switch.

17. Electrically operated architectural covering device according to claim 15 or 16, wherein the rechargeable power source is a Nickel Metal Hydride accumulator.

18. Electrically operated architectural covering device according to any one of claims 15 to 17, wherein the step-up converter includes a MOSFET semiconductor element.

19. Electrically operated architectural covering device according to claim 18, wherein the MOSFET semiconductor element is supplementary to a semiconductor switch, which semiconductor switch is adapted to operate the step-up converter during periods when output voltage of the photovoltaic cell offered to the step-up converter is too low for the MOSFET semiconductor element to operate.

20. Electrically operated architectural covering device according to claim 15, wherein the step-up converter includes a Schottky diode.

21. Electrically operated architectural covering device according to claim 15, wherein the step-up converter comprises an oscillator circuit for generating a pulsed voltage for addition to the output voltage of the photovoltaic cell.



22. Electrically operated architectural covering device according to claim 21, wherein the step-up converter is associated with an oscillator circuit generating a pulsed voltage to which the output voltage of the photovoltaic cell is added by means of a Schottky diode, before it is offered to a base of the semiconductor switch.



23. Electrically operated architectural covering device according to claim 15, wherein the step-up converter includes a start-up circuit, having a resonant triggering circuit using an extra coil, thereby taking less current to step-up.

24. Electrically operated architectural covering device according to any one of claims 15 to 23, wherein the second circuit includes a step-up converter for increasing the voltage of the rechargeable power source to a level necessary for the operation of the electric motor.

25. Electrically operated architectural covering device according to any one of claims 15 to 24, wherein the photovoltaic cell is connected to the first rail through electrical leads for mounting at a location independent of the head rail.

26. Electrically operated architectural covering device according to any one of claims 15 to 24, wherein the photovoltaic cell is adapted to be fixedly mounted to an inward facing surface of the first rail.

27. Electrically operated architectural covering device according to any one of claims 15 to 26, wherein the rechargeable power source is a metal hydride accumulator.

28. Electrically operated architectural covering device according to any one of claims 15 to 26, wherein the rechargeable power source is alkaline manganese battery.

29. Electrically operated architectural covering device according to any one of claims 15 to 26, wherein the rechargeable power source is a lithium ion battery.

 30. Electrically operated architectural covering device according to any one of claims 15 to 29, wherein the rechargeable power source has a capacity not exceeding 1.4 Ah.

 31. Electrically operated architectural covering device according to any one of claims 15 to 30, wherein the rechargeable power source is a 3.6 V battery system.

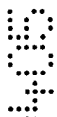
 32. Electrically operated architectural covering device according to any one of claims 15 to 31, wherein the covering member comprises an extendible and retractable pleated window covering.

33. Electrically operated architectural covering device according to any one of claims 15 to 31, wherein the covering member comprises an array of operatively interconnected slats, each having an open and a closed position within the covering member.
34. Electrically operated architectural covering device according to any one of claims 15 to 33, wherein the operation of the electric motor does not exceed 40 seconds per day.
35. Electrically operated architectural covering device according to claim 34, wherein the electric motor operates on 12 V DC.
36. Electrically operated architectural covering device according to claim 34 or 35, wherein the daily power requirement of the electric motor is about 50 mWh/day.
37. A drive assembly for an electrically operated architectural covering device, including a motor and the power supply of any one of claims 1 to 14.
38. A drive assembly substantially as herein described with reference to any one of the embodiments of the invention illustrated in the accompanying drawings.
39. A power supply substantially as herein described with reference to any one of the embodiments of the invention illustrated in the accompanying drawings.
40. An electrically operated architectural covering device substantially as herein described with reference to any one of the embodiments of the invention illustrated in the accompanying drawings.



DATED this 15th day of April, 2004
Shelston IP
Attorneys for: TURNILS A.B.



Fig 1

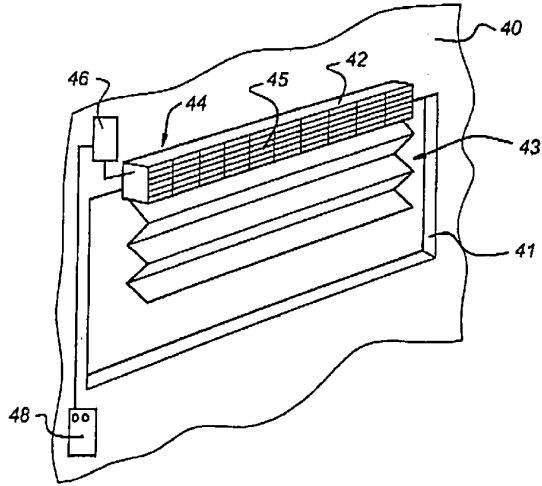
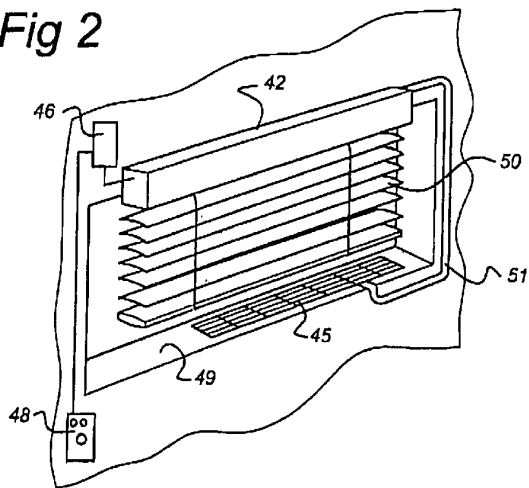
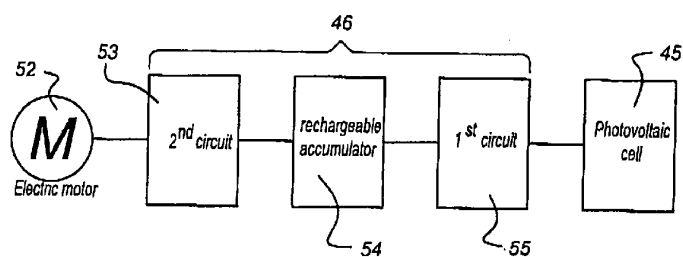

Fig 2



Patent
Office

Fig 3



U
S
S
R

1346 1701

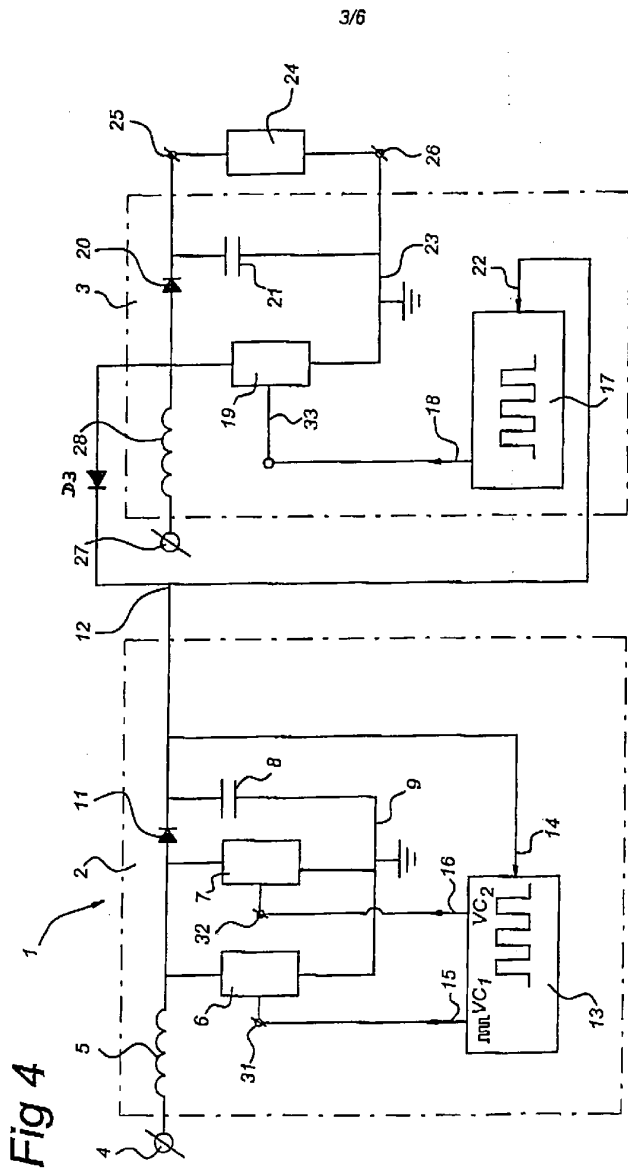

30 01 02 14700

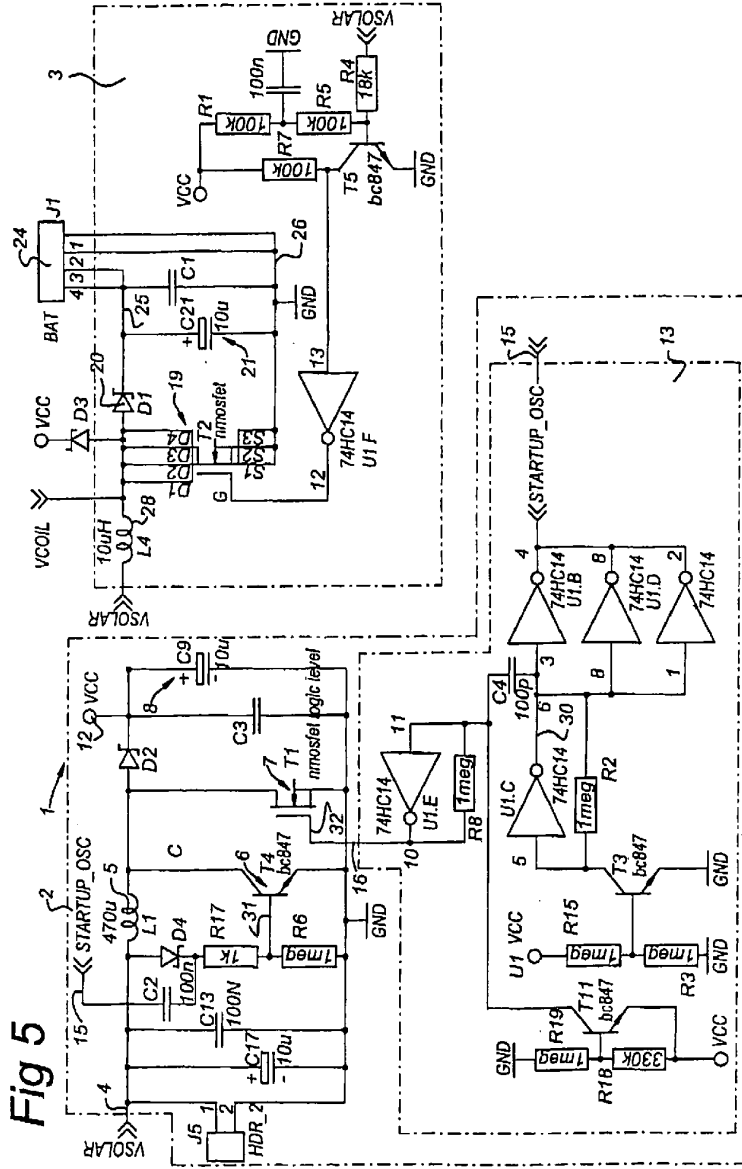
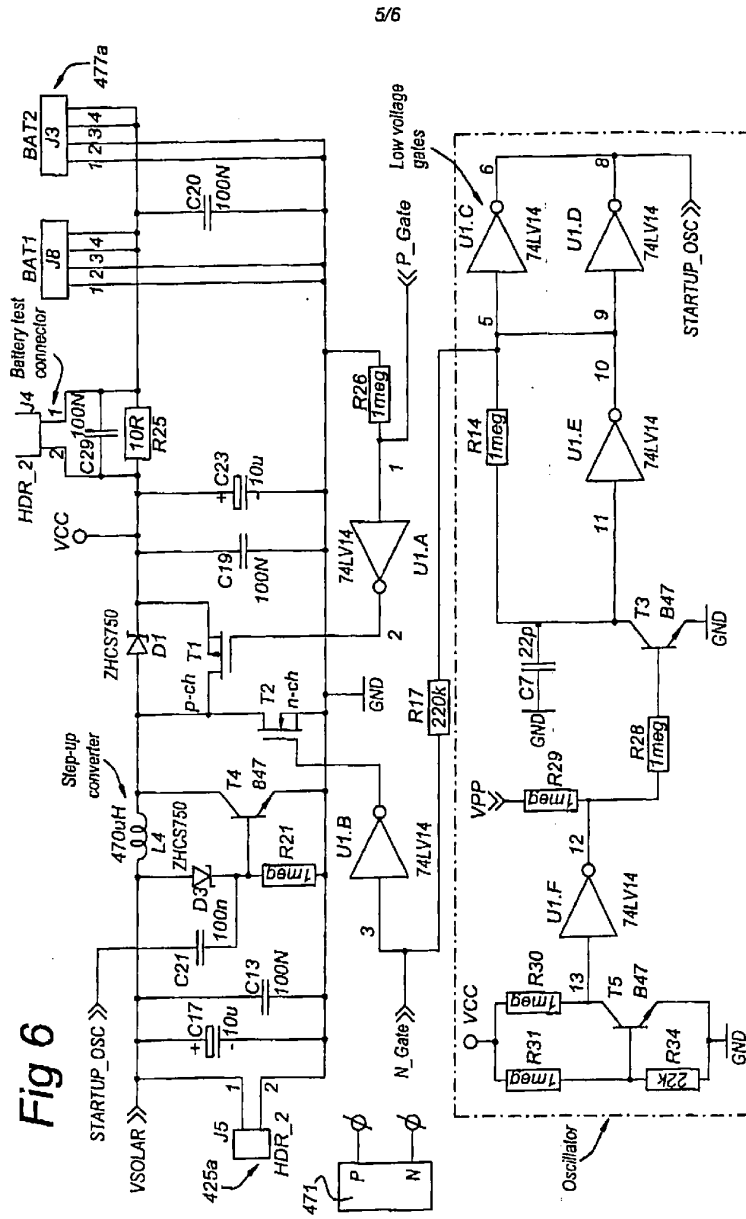

Fig 5

30 01 02 14700

Fig 6



5/5

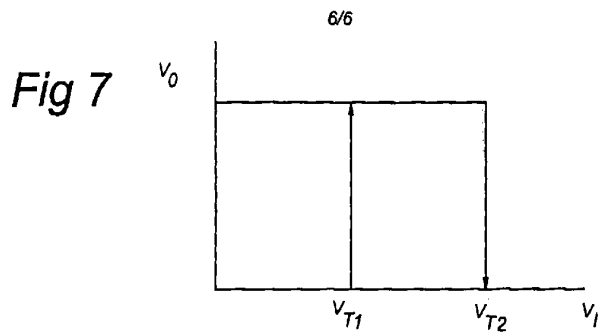

Fig 8

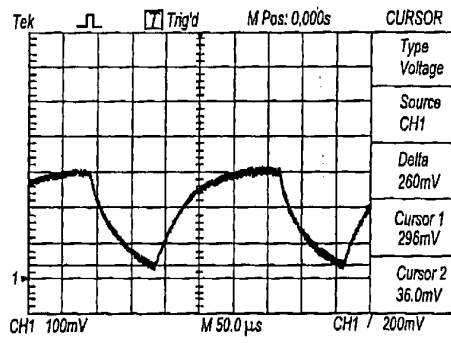

Fig 9

