



(86) Date de dépôt PCT/PCT Filing Date: 1996/02/02  
 (87) Date publication PCT/PCT Publication Date: 1996/08/22  
 (45) Date de délivrance/Issue Date: 2001/09/11  
 (85) Entrée phase nationale/National Entry: 1996/10/15  
 (86) N° demande PCT/PCT Application No.: JP 96/00224  
 (87) N° publication PCT/PCT Publication No.: WO 96/25284  
 (30) Priorité/Priority: 1995/02/16 (7-65313) JP

(51) Cl.Int.<sup>6</sup>/Int.Cl.<sup>6</sup> B29C 49/22, B29C 49/50

(72) Inventeurs/Inventors:

Hisama, Hiroyuki, JP;  
 Seguchi, Masato, JP;  
 Sako, Isamu, JP;  
 Sato, Jyoji, JP;  
 Honda, Masato, JP

(73) Propriétaire/Owner:

Yoshino Kogyosho Co., Ltd., JP

(74) Agent: SMART & BIGGAR

(54) Titre : CONTENANT MOULE PAR SOUFFLAGE ET MOULE CONNEXE

(54) Title: BLOW MOLDED CONTAINER AND BLOW MOLD THEREOF

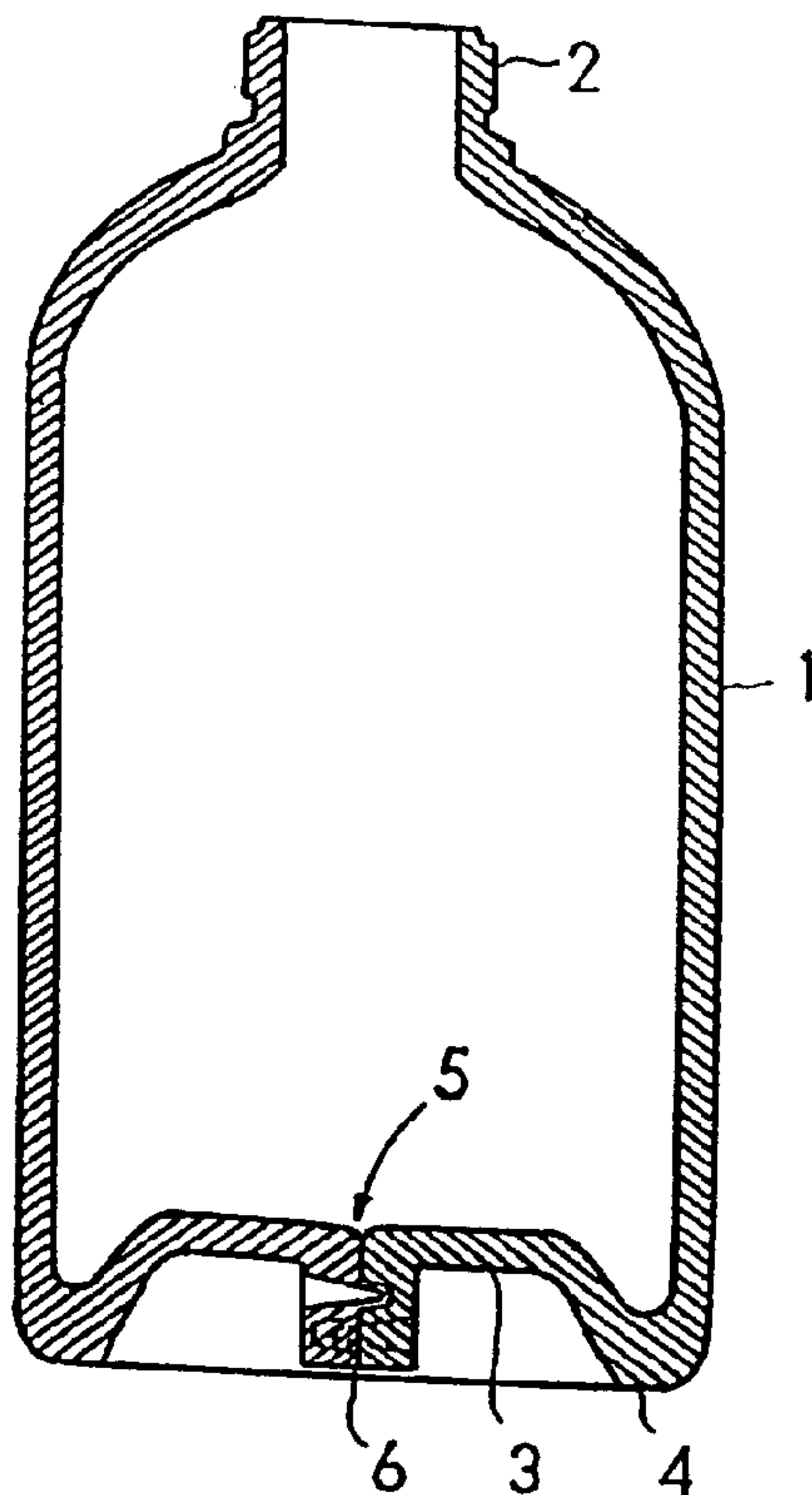

(57) Abrégé/Abstract:

A container is formed by a blow molding method in which a cylindrical parison made of a single layer or multilayer resin material is inflated by air while heated inside a mold. A bottom seal section formed by a pinch-off portion of the mold has a portion projecting outside the container, and one of the resin layers constituting this projection bites into the other resin layer to form a bite portion. Accordingly, the fusion strength can be increased by increasing the fusion area between the resin layers, and the bite portion increases the strength against shearing force parallel to the fusion surface.

## ABSTRACT

A blow molded container of the present invention is a container formed by blow molding in which a single-layer or multi-layer parison comprising a cylindrical resin material is heated and inflated by air in a mold, wherein a bottom  
5 sealing portion formed by pinch offs of the mold has a projection projecting outwardly from the container and sunk portions formed in one of the resin layers constituting the projection such a manner as to be buried in the other resin layer. Therefore, the bonded area between the resin layers is widened, thereby having higher bond strength and higher strength against the shearing force along the  
10 fusion bonded area

## SPECIFICATION

## BLOW MOLDED CONTAINER AND BLOW MOLD THEREOF

## Technical Field

5           The present invention relates to a blow molded container with a featured bottom sealing portion and a blow mold used for the blow molding.

## Background Art

10           It is known that a bottom sealing portion formed by pinch-offs of the mold is projected to strengthen the bottom sealing portion of a single-layer or multi-layer blow molded container (for example, Japanese Published Unexamined Utility Model Application No. H03-3460, Japanese Utility Model Publication No. H06-11164).

15           Such a container with a projected bottom sealing portion has higher bond strength than a normal type. However, when the container is a plastic container made of material providing weak pinch-off portions against drop impact such as polyethylene terephthalate or polypropylene or when the container is a large-volume plastic container, there is a problem of cracking in the bottom sealing portion when the container drops down with the content therein.

20           A multi-layer blow molded container, of which an inner layer and an outer layer can be freely separated from each other to completely pour out the content, is well known (see, for example, Japanese Published Unexamined Patent Application No. H05-310265).

25           In the conventional container, when pouring out the content, the outer layer is maintained in the container's profile while the inner layer is deformed due to the depressurization. Therefore, air is entrapped into the separated part between the outer layer and the inner layer.

          However, since air is entrapped from a slit formed between the edges of the outer layer at the bottom pinch-off portion, the container also entraps

64881-476

2

moisture when the container is used in a damp area such as a bathroom. In addition, there is a problem that the decrease in the content can not be viewed.

Then, a container with a slit formed in the outer layer at the upper side and of which the inner layer and the outer layer are bonded at the bottom pinch-off portion has been proposed. However, since the container must be made of resin with low bond strength in order to separate the outer layer and the inner layer from each other, the cracking of the bottom sealing joint and the occurrence of slit due to the separation between layers cannot be prevented with the conventional configuration of the bottom pinch-off portion.

To overcome the aforementioned problems, it is a first object of this invention to provide a blow molded container with strengthened bottom sealing portion and a blow mold used for the blow molding and it is a second object of this invention to provide a separable multi-layer plastic container in which the bottom sealing portion is improved not to entrap moisture from the bottom by the above technique and the inner layer can be smoothly separated to completely consume the contents.

#### Summary Of The Invention

The invention provides a blow molded container formed by blow molding a cylindrical parison comprising a resin material in a blow mold, wherein the blow mold includes splits, each of said splits having pinch-offs and opposing projections facing one another at different heights disposed proximate to the pinch-offs wherein said blow molded container comprises: a body formed of resin layers, said pinch-offs holding the parison and fusion bonding the resin layers to one another, and pinching off residual resin formed while the resin layers are fusion bonded; a bottom sealing portion formed by the pinch-



64881-476

2a

offs during the fusion-bonding of the resin layers, the bottom sealing portion having sunk portions formed by the opposing projections in each of the resin layers, the sunk portions in each of the resin layers being at offset heights with respect to the pinch-offs, said offset heights substantially corresponding to the heights of the opposing projections.

The invention also provides a blow molded container formed by blow molding a cylindrical parison comprising a resin material, the blow molded container having a body, a neck and bottom formed from resin layers, the blow molded container further comprising: a bottom sealing portion proximate to the bottom of the container, the bottom sealing portion defined as a projection projecting downward and outward; a fusion bonding portion that bonds the resin layers proximate to the projection; sunk portions formed in the resin layers wherein the sunk portion on one resin layer being buried in another resin layer and the one sunk portion being at an offset height from the another sunk portion with respect to the bottom sealing portion; and projecting ends disposed proximate to the sunk portions, respectively, wherein the sunk portions and the projecting ends strengthen the bottom sealing portion.

formed in one of the resin layers constituting said projection such a manner as to be buried in the other resin layer.

Since the mold pinches the cylindrical parison, the bottom sealing portion is formed as a strip-like projection projecting outwardly and downwardly from the bottom of the container and extending along a parting line of the mold.

Since the bottom sealing portion is provided with the sunk portions, the resin layers constituting the bottom sealing portion which are bonded together are engaged with each other.

Since the resin layers are bonded in the engaged state with the sunk portions formed in the respective resin layers, the bonded area between the resin layers is widened so that the bond strength of the bottom sealing portion is improved and the container has higher strength against the shearing force along the fusion bonded area.

The container of the present invention may have a laminated (multi-layer) structure formed by a plurality of resin layers. The container may be characterized in that the resin layers are of different types from each other and the inner resin layer is separable from the outer resin layer. The container provides useful advantages in case of having a fluid pumping device at the neck thereof. That is, as the fluid in the container is pumped out by the fluid pumping device, negative pressure is developed in the container according to the decrease of the fluid. The negative pressure separates the inner layer from the outer layer of the laminated container so that the inner layer shrinks without change in the configuration of the container.

In such a separable multi-layer plastic container, the aforementioned structure of the bottom sealing portion is employed for the bottom of the container and the container is provided with a path for communicating with the atmosphere at an upper portion thereof so that the atmospheric air is introduced between the inner layer, thereby facilitating the separation of the inner layer and the shrinkage of the separated inner layer.

64881-476

4

Since the path is formed in the upper portion of the container, the container is prevented from entrapping moisture so that the inner bag can be smoothly separated to completely pour out the content. This is an advantage for a container  
5 used in a damp area such as a shampoo container. The path as mentioned above may be a slit, an opened hole, or the like.

Particularly for such a separable multi-layer plastic container, providing the sunk portions effectively improves the strength of the bottom sealing portion. That is, by improving  
10 the bottom sealing portion in the separable multi-layer plastic container, the bottom sealing portion can be strongly bonded even when the inner bag is made of resin such as nylon providing weak bond strength, thereby preventing the occurrence of slit due to the separation between the layers.

15 The invention also provides a blow mold in which a cylindrical parison comprising a resin material is heated and inflated by fluid, said blow mold comprising: splits facing each other to form a cavity for molding a container inside the splits, each of said splits having a pinch-off positioned at a  
20 bottom of the container, each said pinch-off holding the parison and fusion-bonding resin layers to form a bottom sealing portion of the container, each said pinch-off further pinching off residual resin formed while said resin layers are being fusion-bonded; each said pinch-offs having a stepped  
25 portion forming a concavity for molding the bottom sealing portion when superposing on each other; and at least one projection formed on each of said splits a first projection on one of said splits being at a different height than a second projection on another one of said splits, the projection on the  
30 one split being pushed to partially enter into the resin layer of said concavity at the stepped portion of the pinch-off and the projection on the other split being pushed to partially enter the other resin layer of said concavity, the first and



64881-476

4a

second projections entering the resin layers at different heights.

The protrusions may be pins for pushing the resin layer of the parison.

5 In the blow mold, since the splits have stepped portions disposed at the pinch-offs and protrusions disposed at the stepped portions so as to make sunk portions in the resin layers, thereby facilitating the fusion bond between the resin layers in the engaged state.



### Brief Description of Drawings

Fig. 1 is a front view showing a single-layer blow molded container according to the present invention;

5 Fig. 2 is a sectional view taken along the line A-A' of Fig. 1;

Fig. 3 is an enlarged sectional view of a bottom sealing portion of the single-layer blow molded container according to the present invention;

Fig. 4 is an enlarged sectional view of a bottom sealing portion of a multi-layer blow molded container according to the present invention;

10 Fig. 5 is a front view showing a blow mold according to the present invention before pinching a parison;

Fig. 6 is a front view showing the blow mold according to the present invention with the parison being compressed and bonded to engage resin layers each other;

15 Fig. 7 is a perspective view showing the blow mold according to the present invention with the section being the center of pinch-off;

Fig. 8 is a front view of a separable multi-layer plastic container according to the present invention;

20 Fig. 9 is a side view of the separable multi-layer plastic container according to the present invention;

Fig. 10 is a sectional view of the separable multi-layer plastic container taken along the line A-A' of Fig. 8, with the inner bag being separated;

Fig. 11 is an enlarged sectional view of a bottom sealing portion of the separable multi-layer plastic container, taken along the line A-A' of Fig. 8; and

25 Fig. 12 is a sectional view taken along the line B-B' of Fig. 8.

### Best Mode for Carrying Out the Invention

Hereinafter, embodiments of the present invention will be described with reference to attached drawings.

Fig. 1 and Fig. 2 show a single-layer blow molded container according to the present invention.

In those figures, the mark A designates a single-layer plastic container made by blow molding from single-layer parison made of resin such as polyethylene terephthalate or polypropylene. A container made of such resin generally has weak pinch-off portions against drop impact. The container comprises a body 1, a neck 2, a bottom face 3, and a bottom end 4 for standing the container.

The bottom face 3 is provided with a bottom sealing portion 5 formed by pinch-offs of the mold. The bottom sealing portion 5 is formed as a strip-like projection 6 projecting outwardly and downwardly from the bottom of the container and extending along a parting line of the mold.

The section of the bottom sealing portion 5 is shown in Fig. 3. Before the detail description of the structure of the bottom sealing portion 5, the blow mold of the present invention and the operation thereof will now be described with reference to Figs. 5 through 7.

The blow mold 20 comprises two splits 20a, 20b facing each other, which have cavities 21a, 21b formed in the same configuration of the container and pinch-offs 22a, 22b for pinching off the parison P as a molding material, respectively.

The pinch-offs 22a, 22b comprise pinch-off blades 23a, 23b each provided with relief 24a, 24b formed at the lower portion thereof, stepped portions 25a, 25b each formed behind the tip of the pinch-off blade, and pins 26a, 26b projecting from the stepped portions 25, respectively.

Each pinch-off blade 23 and each stepped portion 25 constitute together a concavity for receiving resin layers 7, 8 of the parison P and forming a protrusion 6 as one of projections of the bottom sealing portion.

The pins 26a disposed on the stepped portion 25a and the pins 26b disposed on the stepped portion 25b which face each other are not at the same level to be uniformly spaced each other in the closed state.

5 The pins 26 are each formed in truncated cone such that the ends of the pins 26 press the resin layers 7, 8 to form the projections and sink the projections into the opposite resin layers. The height H of each pin 26 may be set in such a manner that the projections of the resin layers 7, 8 are sunk in the opposite resin layers at least half in the thick direction. Preferably, the height H is 1.3 through 1.5 times of the width W of the pinch-off blades.

10 Too long distance between pins weakens the bond strength, while too short distance introduces interference at the sunk portion. In view of the foregoing, the distance between the pins is suitably selected for practice. The distance between the pins is preferably selected in such a manner that the distance between the axes of the pins is about 2 through 4 times of the diameter of the base  
15 portion of the pin.

Though the pins at the both sides are disposed zigzag in the vertical direction in the above embodiment, the pins may be disposed at the same level in such a manner as to alternate with each other. The pin may be formed in any configuration allowing the formation of a sunk portion by pressing the resin layers.

20 Hereinafter, the operation of the mold during molding will be described.

Fig. 5 shows the blow mold 20 at a point when the parison P comprising multi-layer resin is supplied therein. From this state, the splits 20a, 20b come close to each other until reaching a contact position as shown in Fig. 6.

At this point, the parison P is pressed by the pins 26 and pinched by  
25 the pinch-off blades 23.

When the pinch-offs 22 are positioned as shown in Fig. 6, the opposite resin layers 7, 8 are fusion bonded each other, the projection 6 is formed by the concavities of the pinch-offs 22, and the sunk portions 12 are formed by the pins 26.



At the same time, the lower end of the parison P is cut off by the pinch-off blades 23 and then compressed fluid is blown in the bonded parison P from a blow inlet so that the parison P is deformed in the configuration formed by the cavities 21.

5 Hereinafter, the structure of the molded bottom sealing portion will be described.

In Fig. 3, the numeral 6 designates projection molded by the pinch-offs, 7, 8 designate the resin layers, and 9 designates a fusion bond area.

10 The numeral 10 designates a concavity formed in the resin layer 8 by one of the pins 26b projecting from the stepped portion 25b of the mold. The concavity 10 has a top 11 sunk in the opposite resin layer 7 to form a sunk portion 12b. The resin layer 7 is also provided with a sunk portion 12a in the same manner which is sunk in the opposite resin layer 8.

15 Since the sunk portions are formed and disposed alternatively, the fusion bond area 9 is bonded in the engaged state.

The description will now be made as regard to the effects of the bottom sealing portion. Since the resin layers are bonded in the engaged state, the bonded area between the resin layers is widened, thereby making the bond strength higher.

20 In addition, the sunk portions are disposed at the right angle against the shear force in the longitudinal direction of the projection and the vertical direction of the container, thereby making the bond strength between the layers higher and the strength of the bottom sealing portion higher too.

25 Hereinafter, a multi-layer blow molded container according to the present invention will be described.

Fig. 4 shows a bottom sealing portion of the multi-layer blow molded container. The method of molding a bottle may be the same as molding a single-layer bottle with the same blow mold but using a multi-layer parison.



In those figures, the numerals 7, 8 designate resin layers, 9 designates a fusion bond area, 10 designates a concavity, 11 designates a projecting end, and 12 designates a sunk portion.

5 The resin layers 7, 8 each comprise an outer layer 13, an inner layer 14, and a bonding layer 15. The inner layer 14 is a functional layer made of nylon, EVAL® (ethylene-co-vinyl alcohol), polyethylene terephthalate or the like and the outer layer 13 is a reinforcing layer made of high-density polyethylene, polypropylene or the like.

10 The sunk portions 12 are formed by the pins 26 provided in the pinch-offs in the same manner as the single-layer blow molded container. The fusion bond area 9 is bonded in the engaged state.

15 The fusion bond area is formed in the engaged state with the sunk portion 12 so as to strengthen the bottom sealing portion even when it is made of material such as nylon providing weak bond strength at pinch-offs, thereby preventing the cracking of the bottom.

The resin multi-layer may be any one of other than the aforementioned kinds of resins. It should be understood some kinds of resin may be used without requiring the bonding layer.

20 The description will now be made as regard to a separable multi-layer plastic container according to the present invention with reference to Figs. 8 - 12.

25 In those figures, the mark B designates a separable multi-layer plastic container having an outer layer 30a and an inner layer 30b. The separable multi-layer plastic container B comprises a body 31, a neck 32, a bottom face 33, and a bottom end 34. The neck is provided with a concavity 37 formed by cutting a part of the periphery thereof, and a slit 38 for introducing atmospheric air between the inner layer and the outer layer.

The bottom face 33 is provided with a bottom sealing portion 35 with a projection 36 projecting downwardly and formed by pinch-offs of the mold.

The outer layer 30a is made of high-density polyethylene for maintaining the container's profile, while the inner layer is a inner bag made of resin such as nylon or EVAL which is separable from the outer layer and deformable.

5 The numeral 30c designates a separating space between the outer layer and the inner layer.

To form the slit 38 and the bottom sealing portion 35, a blow mold employed is provided with upper pinch offs, for fusion-bonding the inner layers and pinching off the outer layers, at portions corresponding to the concavities of  
10 the neck of the container and bottom pinch offs each having a stepped portion with the aforementioned pins projecting therefrom at the bottom thereof so that during blow molding, the slit 38 is formed by the upper pinch offs and the bottom sealing portion 35 is formed by the bottom pinch-offs.

In case of the container having a slit at the upper end of the body, the  
15 slit can be formed by blow-molding a parison of which diameter is larger than that of the neck of the container by using a blow mold provided with pinch-offs at the bottom and pinch-offs at portions corresponding to the upper end of the container. (Not shown).

The bottom sealing portion 35 of the container is formed by resin  
20 layers 39, 40 constituting the outer layer 30a and the inner layer 30b, respectively.

In Fig. 11 and Fig. 12, the numeral 41 designates a fusion bond area, 42 designates a concavity formed in the resin layer 40 by one of the pins 26b projecting from the stepped portion 25b of the mold, 43 designates a projection end of each concavity at the inner layer side. The projection ends 43 are pressed into  
25 the resin layer 39 to form sunk portions 44b.

The resin layer 39 is also provided with concavities of which projection ends are pressed into the resin layer 40 to form sunk portions 44a.

The aforementioned sunk portions 44a, 44b are alternatively formed and arranged so that the fusion bond area 41 is formed in the engaged state.

The description will now be made as regard to the effects of the separable multi-layer plastic container of the present invention. Since the resin layers are bonded in the engaged state with the sunk portions formed in the respective resin layers, the bond strength of the bottom sealing portion is improved and the container has higher strength against the shearing force along the fusion bonded area so that the bottom sealing portion can be strongly bonded even when the inner bag is made of resin such as nylon providing weak bond strength, thereby preventing the occurrence of slit due to the separation between the layers.

In addition, since the upper portion of the container is provided with the slit for introducing the atmospheric air between the inner layer and the outer layer, the air is introduced as needed without entrapping moisture so that the inner bag can be smoothly separated to completely pour out the content.

#### Industrial Applicability

As structured above, the present invention have following effects.

Since the bottom sealing portion is protuberant and the sunk portions are formed in the respective resin layers to engage the resin layers with each other, the bond strength of the bottom sealing portion is improved and the container has higher strength against the shearing force along the fusion bonded area.

The bottom sealing portion is improved in the bond strength, thereby preventing the cracking of the bottom even when the container is a plastic container made of material providing weak pinch-off portions against drop impact such as polyethylene terephthalate or polypropylene or when the container is a large-volume plastic container.

In the separable multi-layer plastic container, the bottom sealing portion can be strongly bonded even when the inner bag is made of resin such as nylon providing weak bond strength, thereby preventing the occurrence of slit due to the separation between the layers without entrapping moisture from the bottom of the container.

In addition, since the upper portion of the container is provided with the slit for introducing the atmospheric air between the inner layer and the outer layer, the air is introduced as needed without entrapping moisture from the bottom of the container so that the inner bag can be smoothly separated to completely pour  
5 out the content.

Since the container according to the present invention has the effects as mentioned above, the container can be used in various applications. Particularly, when the container is used in a damp area such as a bathroom or a kitchen, the container of the present invention provides extremely useful advantages.  
10



64881-476

13

CLAIMS:

1. A blow molded container formed by blow molding a cylindrical parison comprising a resin material in a blow mold, wherein the blow mold includes splits, each of said splits  
5 having pinch-offs and opposing projections facing one another at different heights disposed proximate to the pinch-offs wherein said blow molded container comprises:

a body formed of resin layers, said pinch-offs holding the parison and fusion bonding the resin layers to one  
10 another, and pinching off residual resin formed while the resin layers are fusion bonded;

a bottom sealing portion formed by the pinch-offs during the fusion-bonding of the resin layers, the bottom sealing portion having sunk portions formed by the opposing  
15 projections in each of the resin layers, the sunk portions in each of the resin layers being at offset heights with respect to the pinch-offs, said offset heights substantially corresponding to the heights of the opposing projections.

2. The blow molded container as claimed in claim 1,  
20 wherein the resin layers of the bottom sealing portion include multi-layer plastics and comprise a plurality of resin layers.

3. The blow molded container as claimed in claim 2,  
wherein an outer layer of the resin layers is provided with a path for communicating with the atmosphere at an upper portion  
25 thereof.

4. The blow molded container as claimed in claim 3,  
wherein the container is provided with a concavity around a periphery of a neck portion and said path is formed in the outer layer of said concavity.

64881-476

14

5. A blow molded container formed by blow molding a cylindrical parison comprising a resin material, the blow molded container having a body, a neck and bottom formed from resin layers, the blow molded container further comprising:

5 a bottom sealing portion proximate to the bottom of the container, the bottom sealing portion defined as a projection projecting downward and outward;

a fusion bonding portion that bonds the resin layers proximate to the projection;

10 sunk portions formed in the resin layers wherein the sunk portion on one resin layer being buried in another resin layer and the one sunk portion being at an offset height from the another sunk portion with respect to the bottom sealing portion; and

15 projecting ends disposed proximate to the sunk portions, respectively, wherein the sunk portions and the projecting ends strengthen the bottom sealing portion.

6. The container as claimed in claim 5, wherein the resin layers comprise an inner layer, an outer layer and a  
20 bonding layer disposed between the inner and outer layers.

7. The container as claimed in claim 6, wherein the neck is provided with a concavity and a slot, the slot introducing air between the inner layer and outer layer, the pins may be considered projections of the blow mold or equivalents thereof.

25 8. A blow mold in which a cylindrical parison comprising a resin material is heated and inflated by fluid, said blow mold comprising:

splits facing each other to form a cavity for molding a container inside the splits, each of said splits having a

64881-476

15

pinch-off positioned at a bottom of the container, each said pinch-off holding the parison and fusion-bonding resin layers to form a bottom sealing portion of the container, each said pinch-off further pinching off residual resin formed while said  
5 resin layers are being fusion-bonded;

each said pinch-offs having a stepped portion forming a concavity for molding the bottom sealing portion when superposing on each other; and

at least one projection formed on each of said splits  
10 a first projection on one of said splits being at a different height than a second projection on another one of said splits, the projection on the one split being pushed to partially enter into the resin layer of said concavity at the stepped portion of the pinch-off and the projection on the other split being  
15 pushed to partially enter the other resin layer of said concavity, the first and second projections entering the resin layers at different heights.

9. The blow mold as claimed in claim 8, wherein each said pinch-off has a leading edge having a blade, the blades  
20 pinching-off the residual resin.

10. The blow mold as claimed in claim 9, wherein the height of the projections are approximately 1.3 to 1.5 time a width of the pinch-off blades.

11. The blow mold as claimed in claim 8, wherein each of  
25 said projections is shaped as truncated cones.

12. The blow mold as claimed in claim 8, wherein a distance between the projections is selected to that a distance between axes of the projections is approximately 2 to 4 times that of a base portion of the projections.



64881-476

16

13. The blow mold as claimed in claim 8, further comprising upper pinch-offs for fusion-bonding and pinching off resin layers at the bottom sealing portion of the container.

SMART & BIGGAR  
OTTAWA, CANADA

PATENT AGENTS



Fig. 1

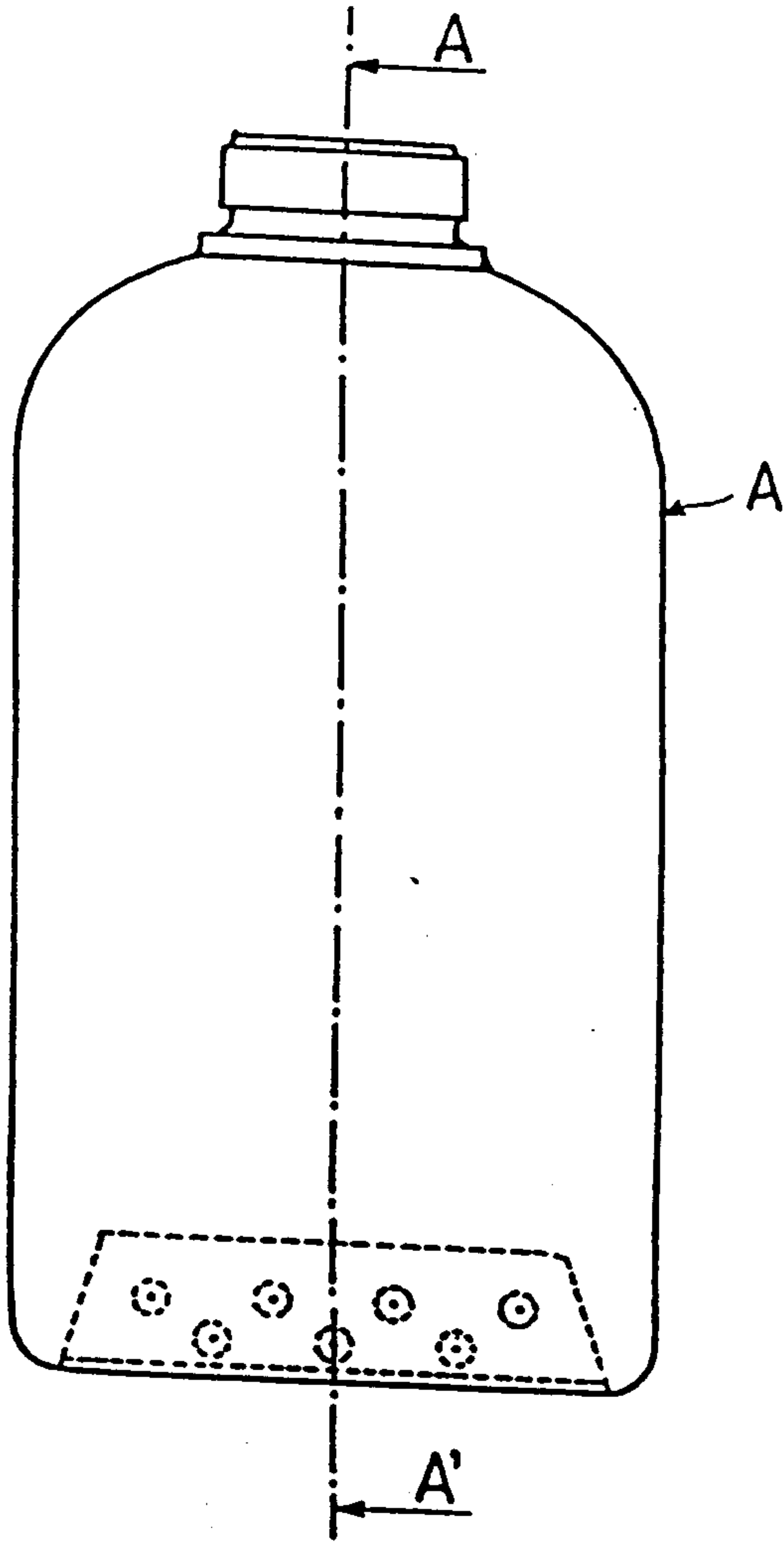

Fig. 2

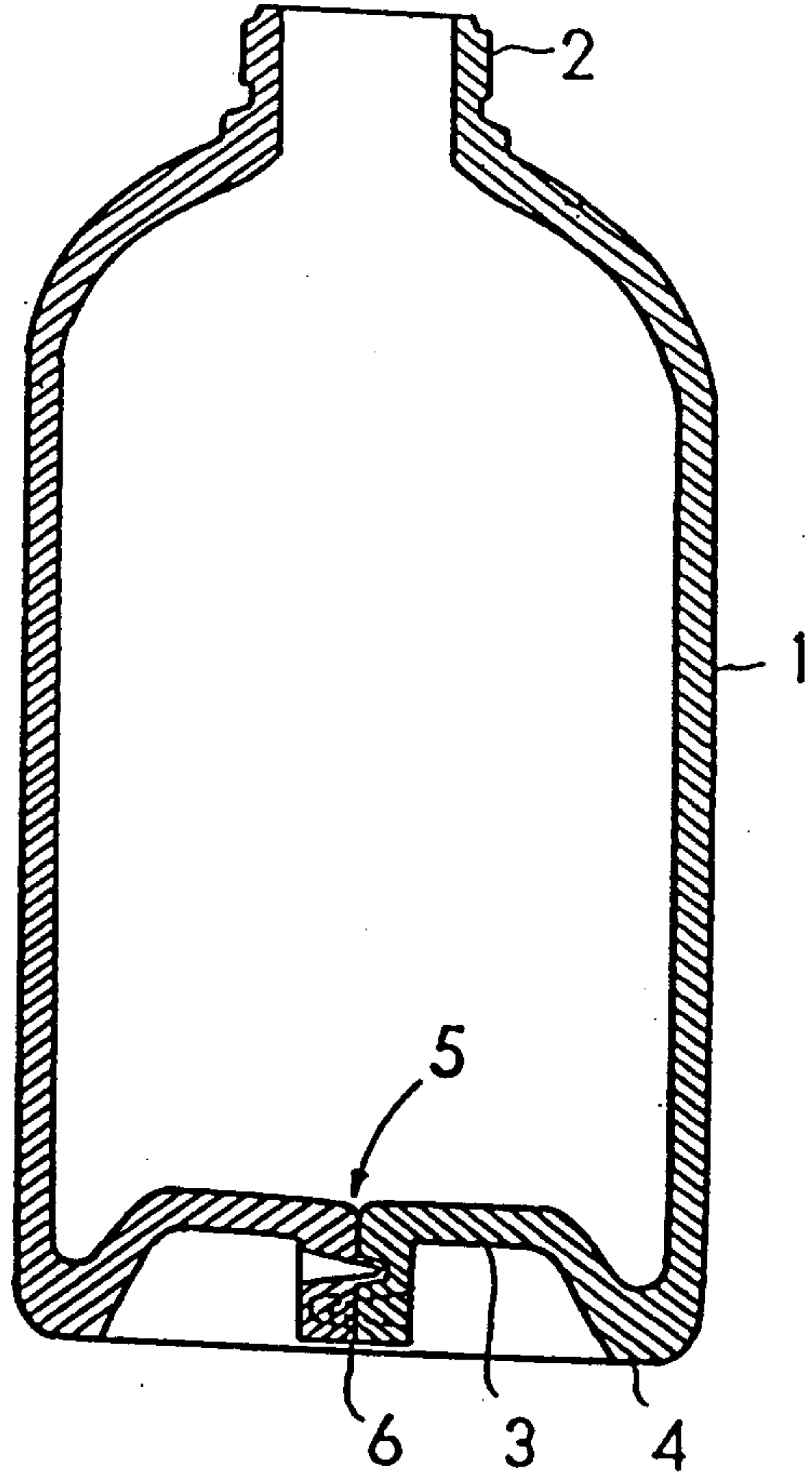

Fig. 3

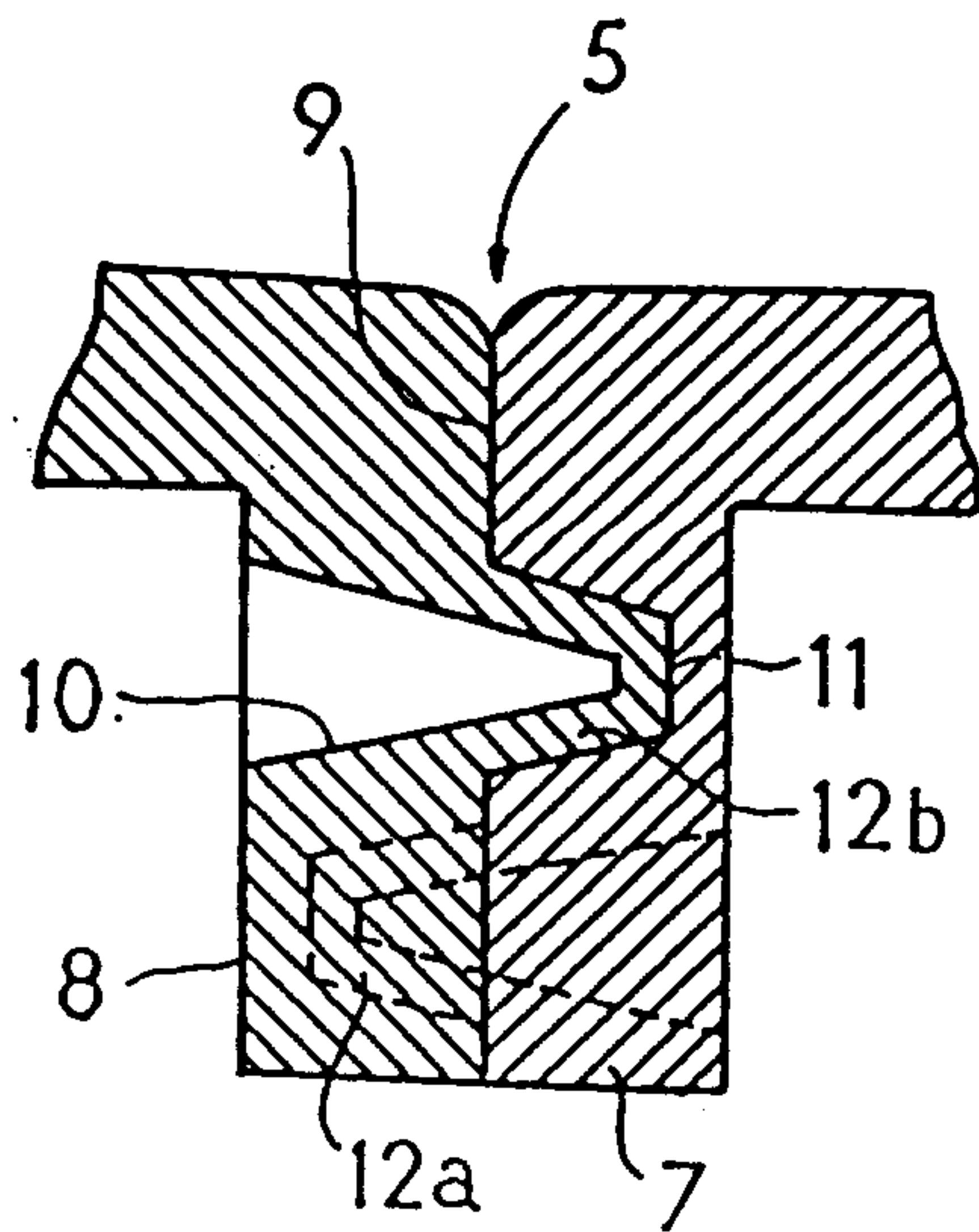

Fig. 4

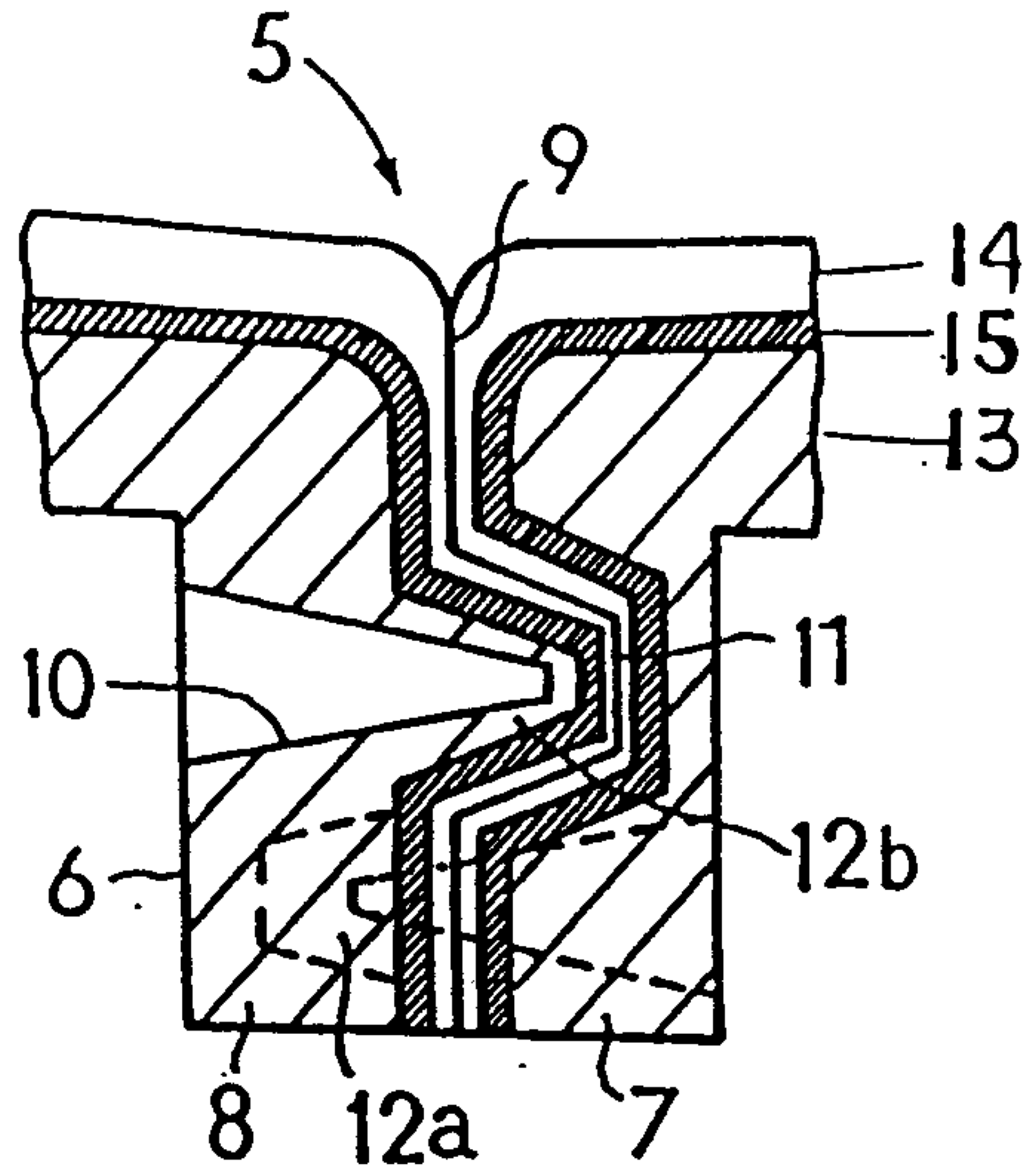

Fig. 5

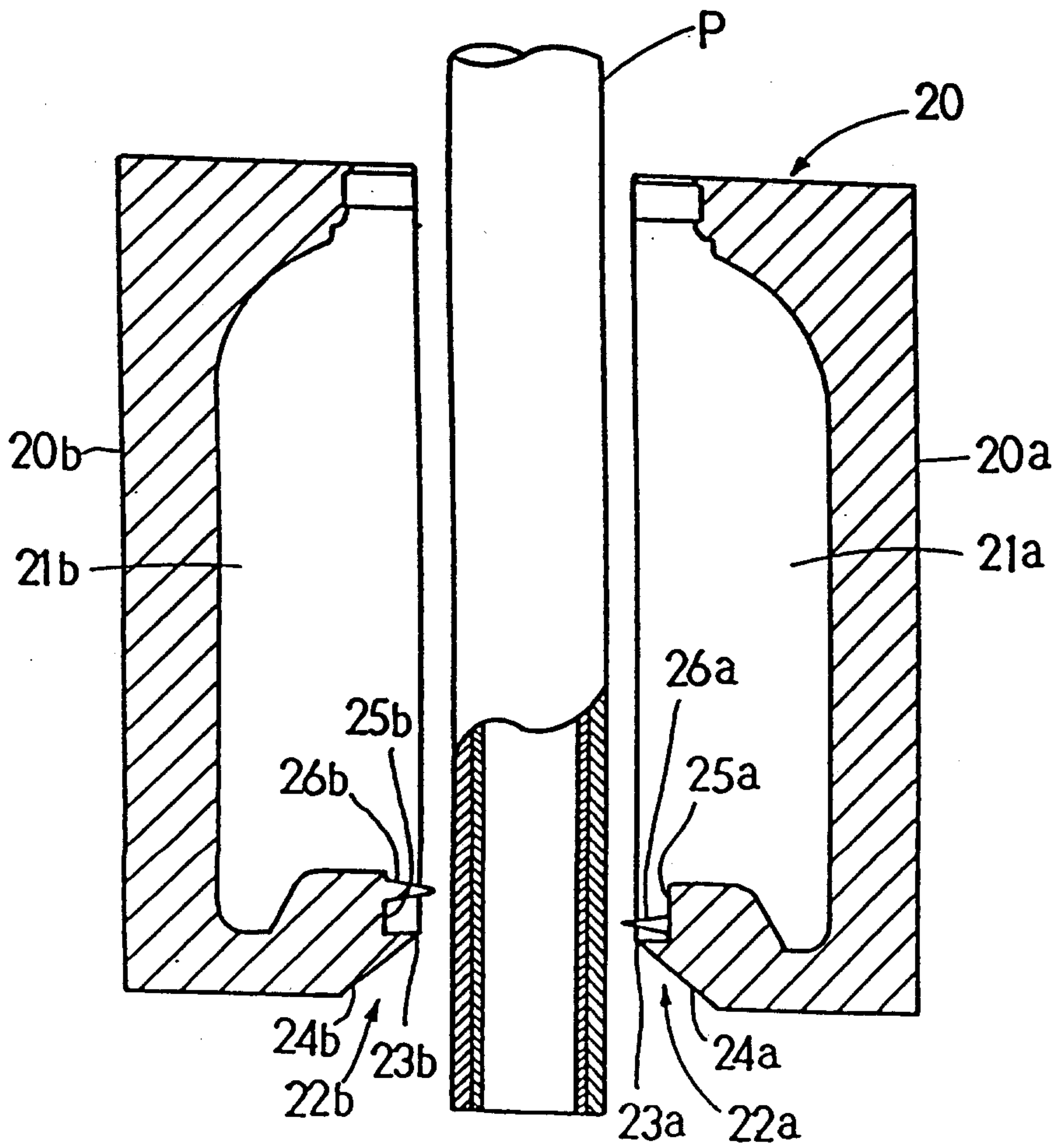

Fig. 6

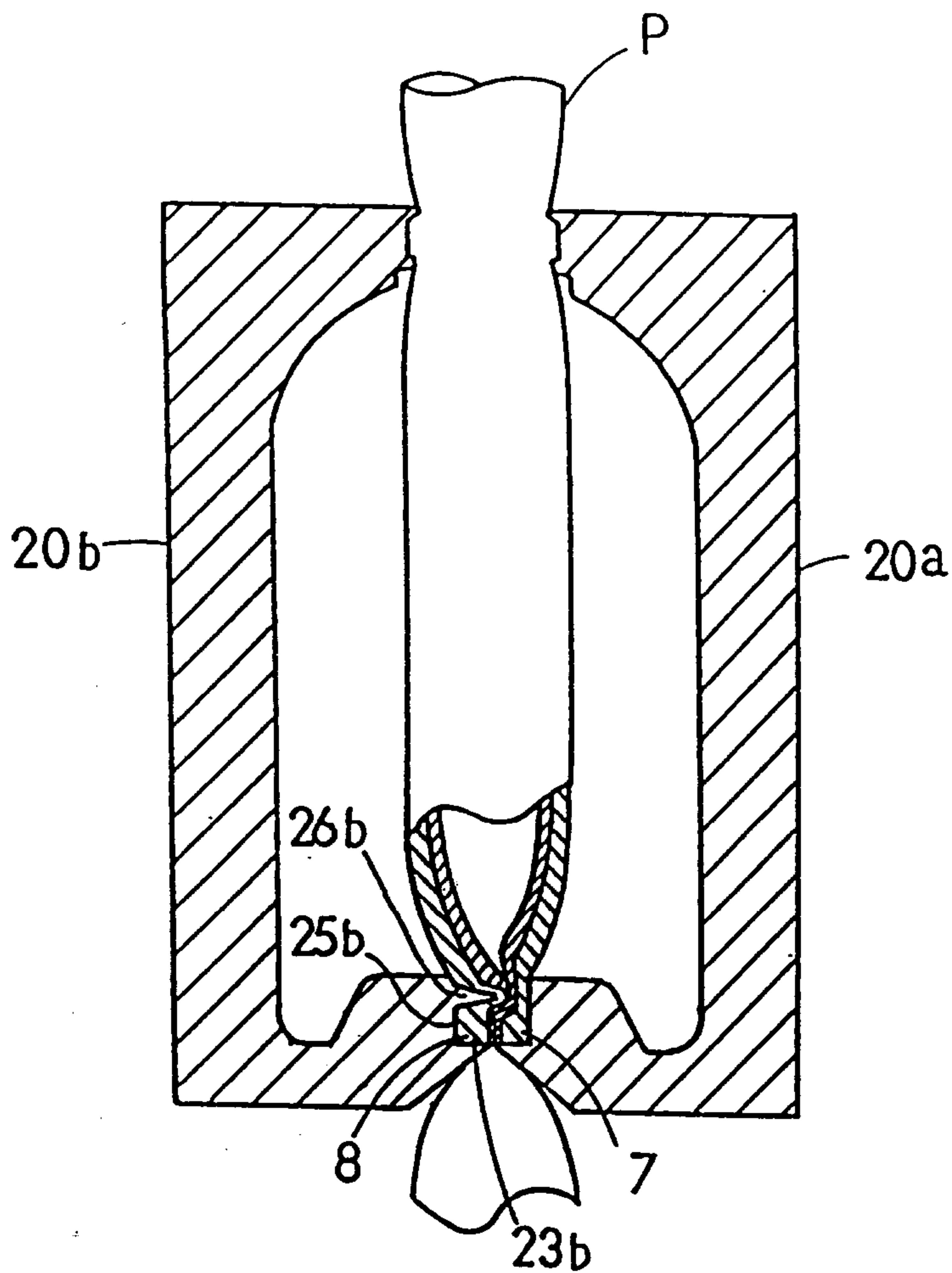
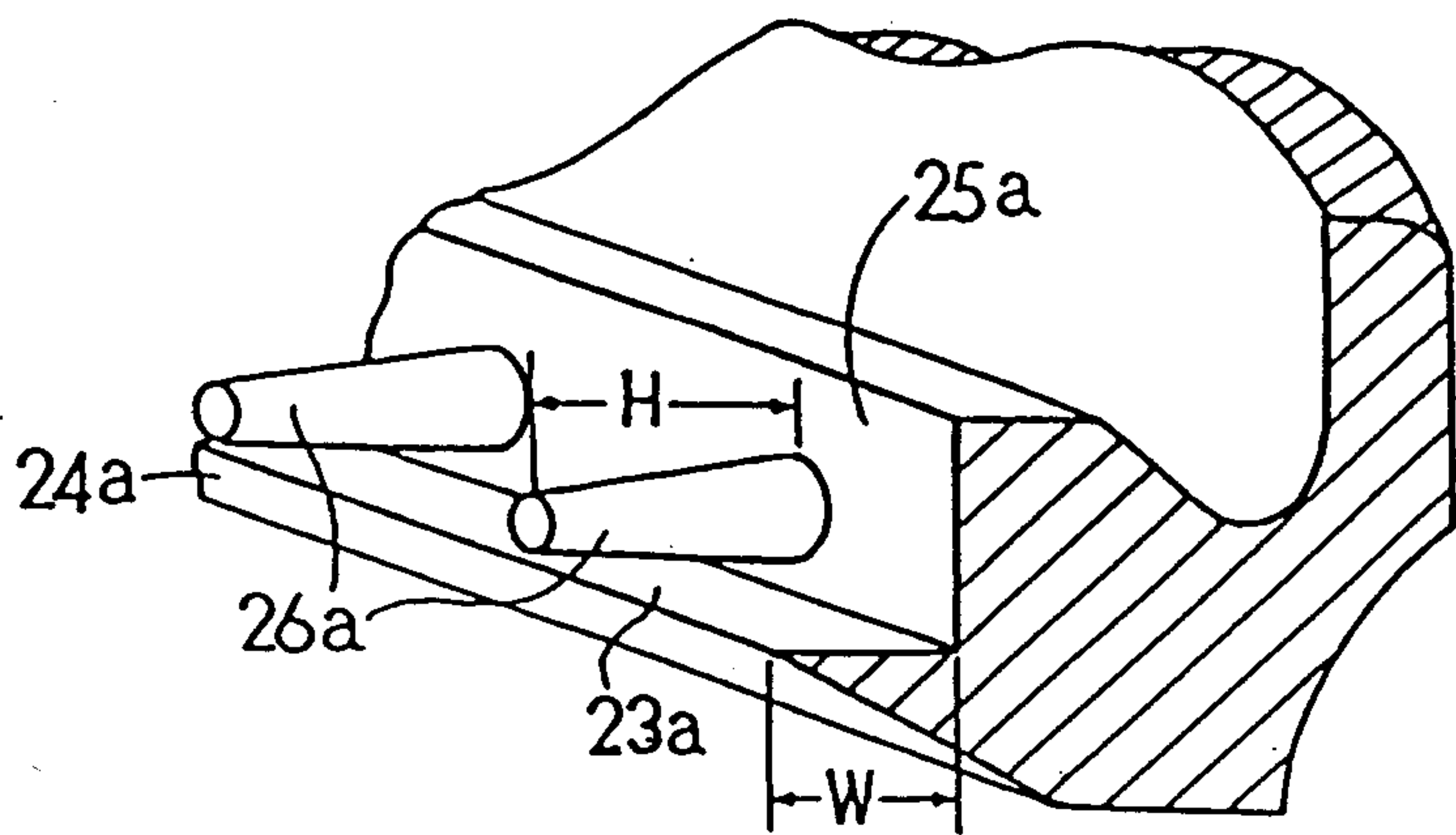

Fig. 7



Printed by  
Singapore

Fig. 8

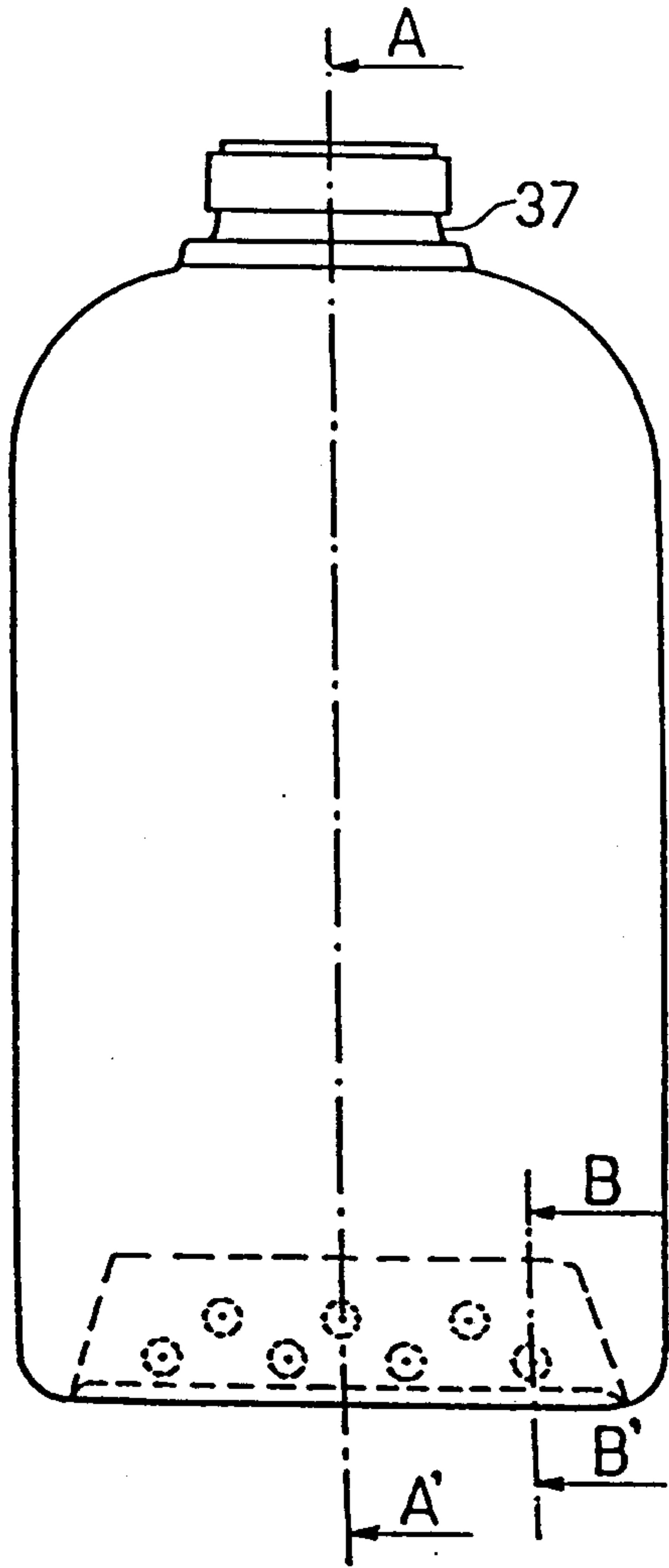

Fig. 9

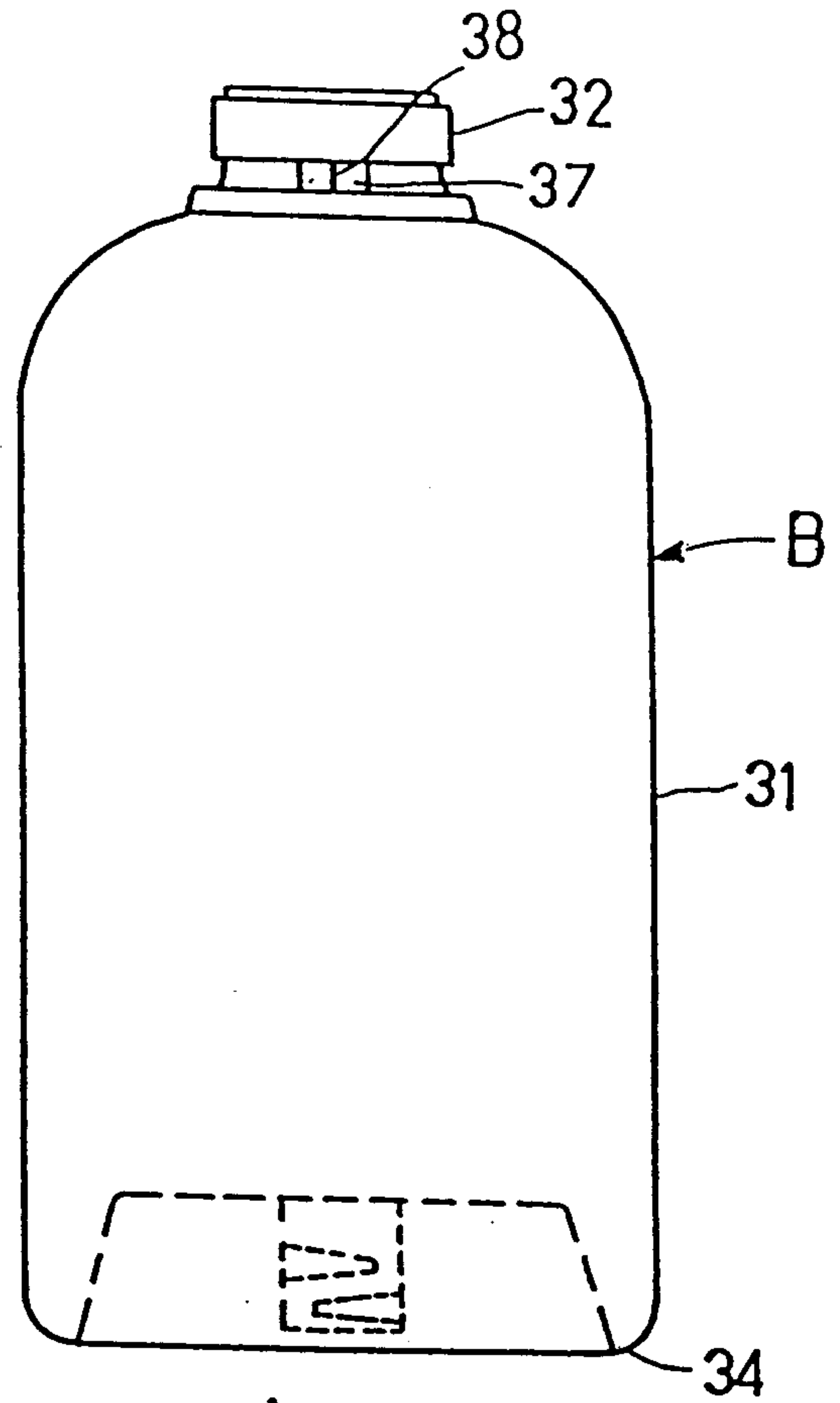



Fig. 10

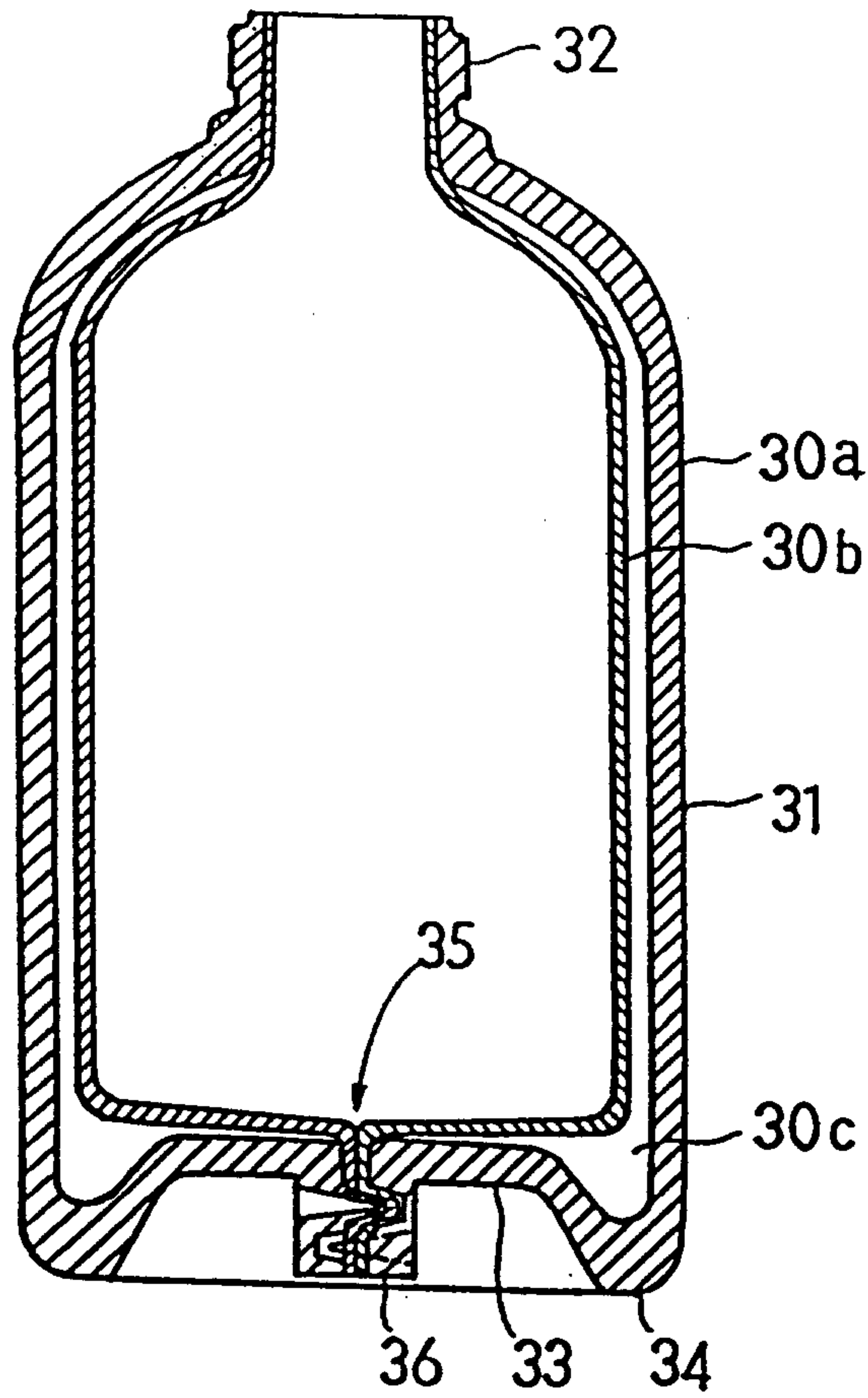

Fig. 11

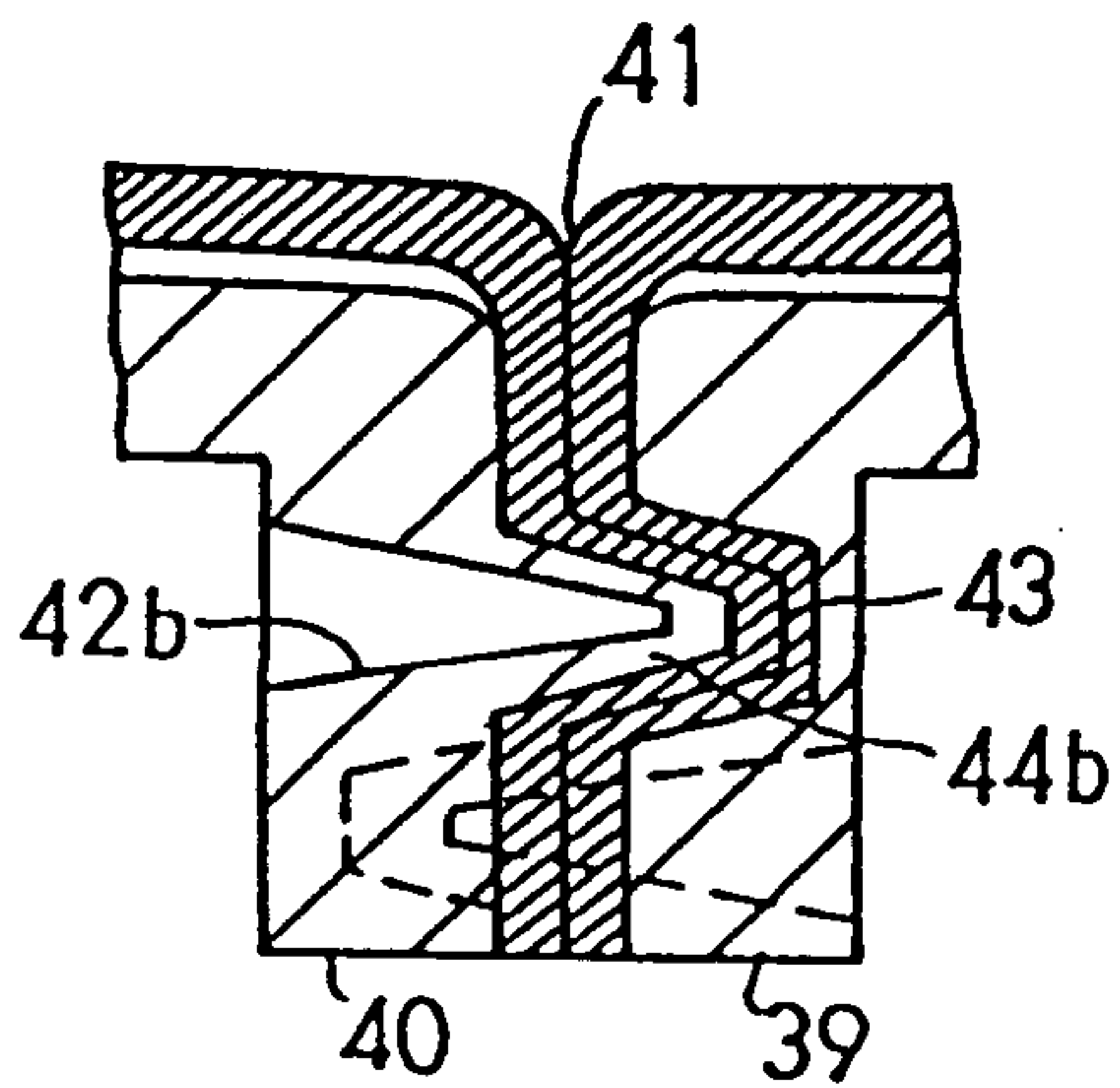

Fig. 12

