

(12) **UK Patent Application** (19) **GB** (11) **2 367 652** (13) **A**

(43) Date of A Publication 10.04.2002

(21) Application No **0024399.8**

(22) Date of Filing **05.10.2000**

(71) Applicant(s)
ARM Limited
 (Incorporated in the United Kingdom)
110 Fulbourn Road, Cherry Hinton, CAMBRIDGE,
CB1 9NJ, United Kingdom

(72) Inventor(s)
Edward Colles Nevill
Andrew Christopher Rose

(74) Agent and/or Address for Service
D Young & Co
21 New Fetter Lane, LONDON, EC4A 1DA,
United Kingdom

(51) INT CL⁷
G06F 9/455

(52) UK CL (Edition T)
G4A AFP

(56) Documents Cited
EP 1102164 A2 **WO 99/61982 A1**
US 5953741 A

(58) Field of Search
 UK CL (Edition S) **G4A AFP APM APX**
 INT CL⁷ **G06F 9/30 9/38 9/445 9/455**
ONLINE: WPI, EPODOC, PAJ

(54) Abstract Title
Scheduling control within a system having mixed hardware and software based instruction execution

(57) A processing system provides both hardware instruction translation (68) and software instruction interpretation (84) mechanisms for supporting high level program instructions. All of the program instructions are supplied to the hardware translation unit (68) which forwards those instructions it does not itself support to the software interpretation mechanism (84). By routing all program instructions through the hardware translation unit (68), the hardware translation unit (86) is able to monitor when it is appropriate and safe to trigger a scheduling operation for controlling multitasking or multithreaded operations. The scheduling operations may be triggered based upon a count of executed program instructions or by using a timer based scheduling approach with the timer signal being qualified by a signal indicating an appropriate point within the cycle of execution of program instructions. The embodied apparatus uses Java (RTM) Byte code.

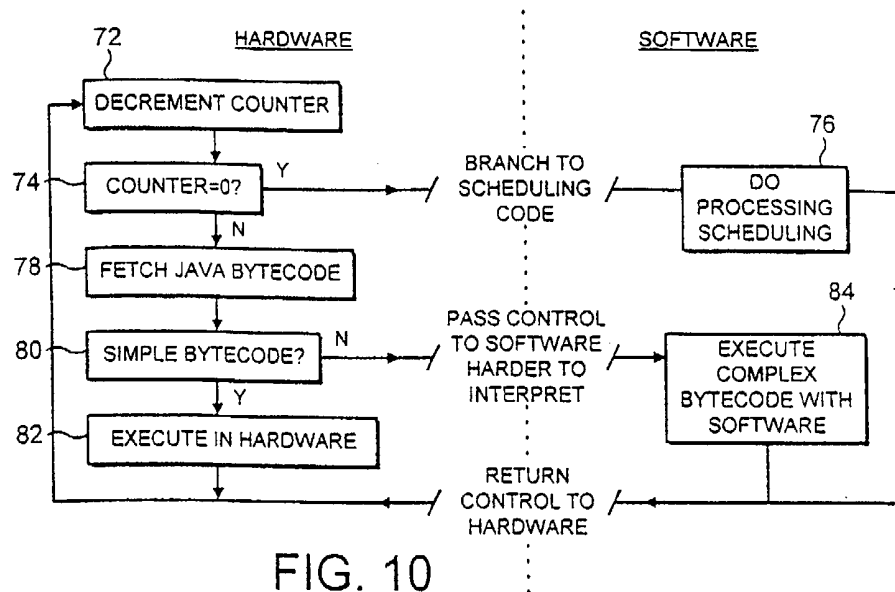

FIG. 10

GB 2 367 652 A

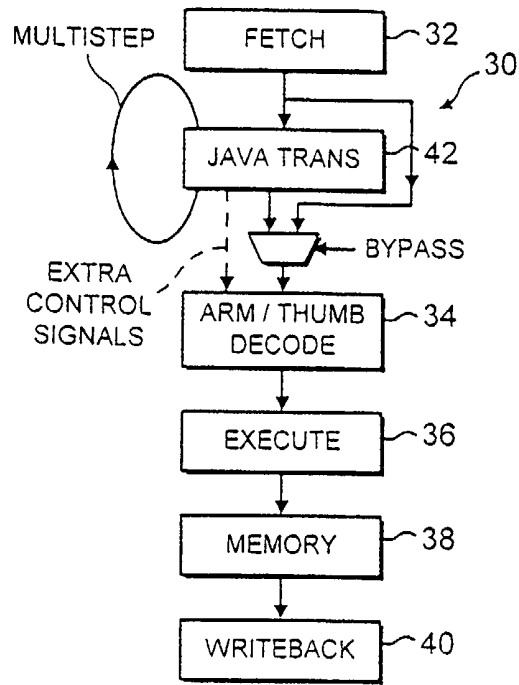

FIG. 1

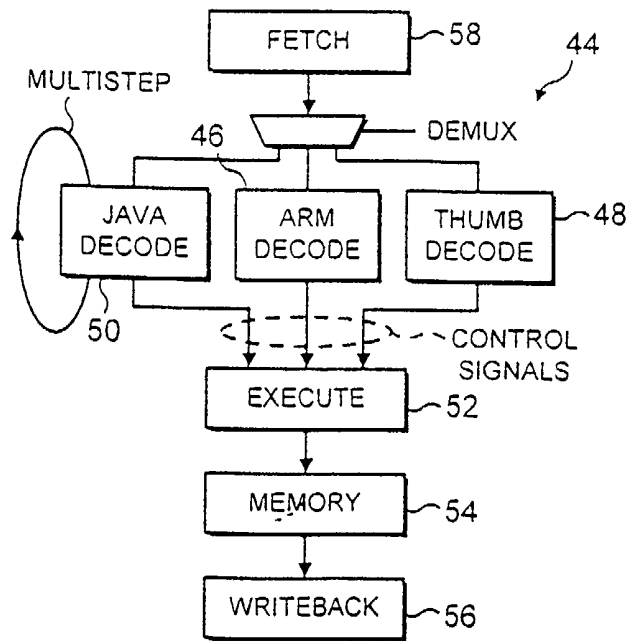

FIG. 2

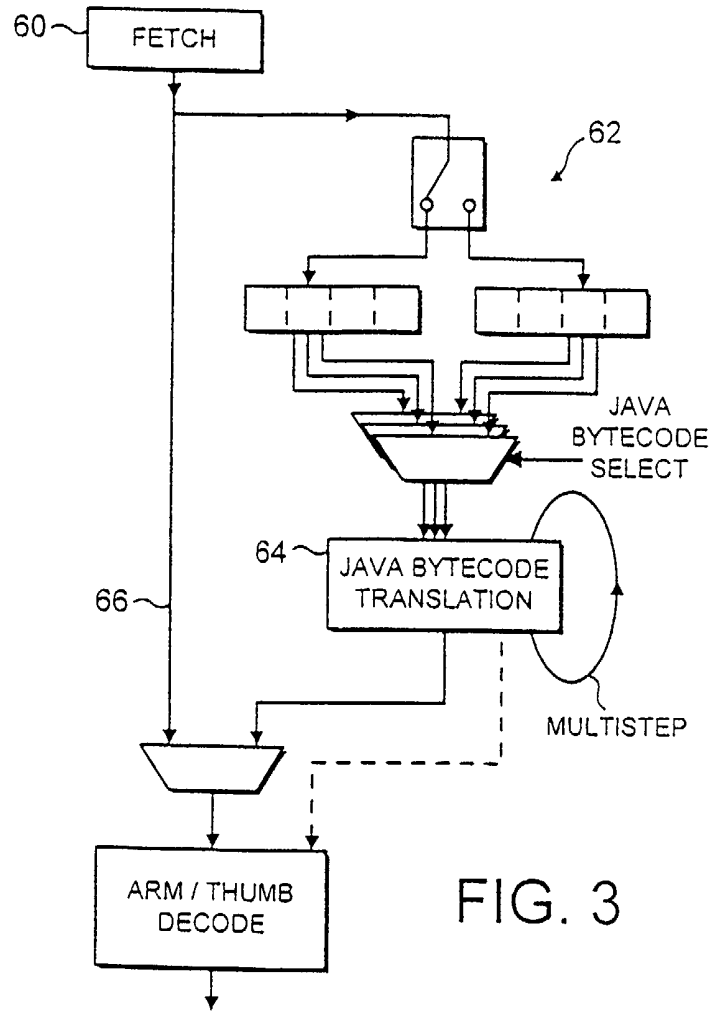

FIG. 3

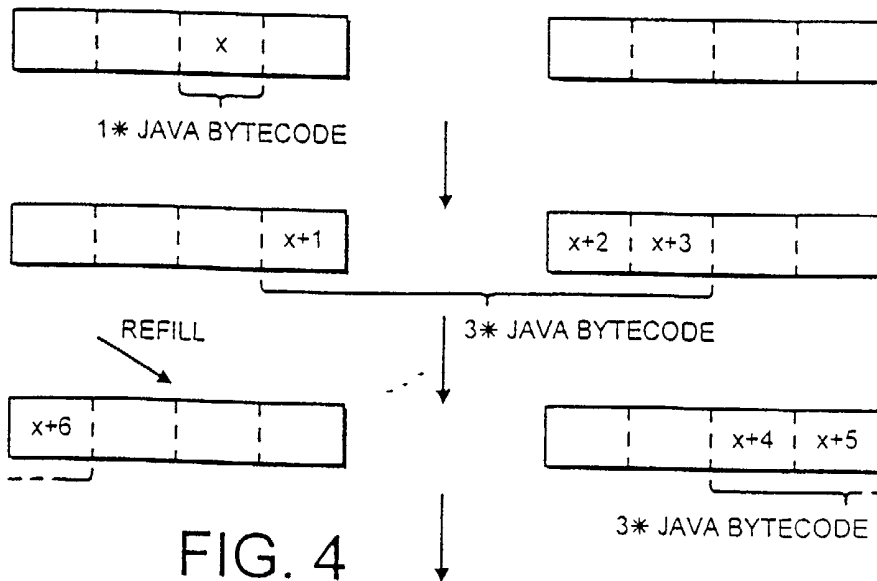

FIG. 4

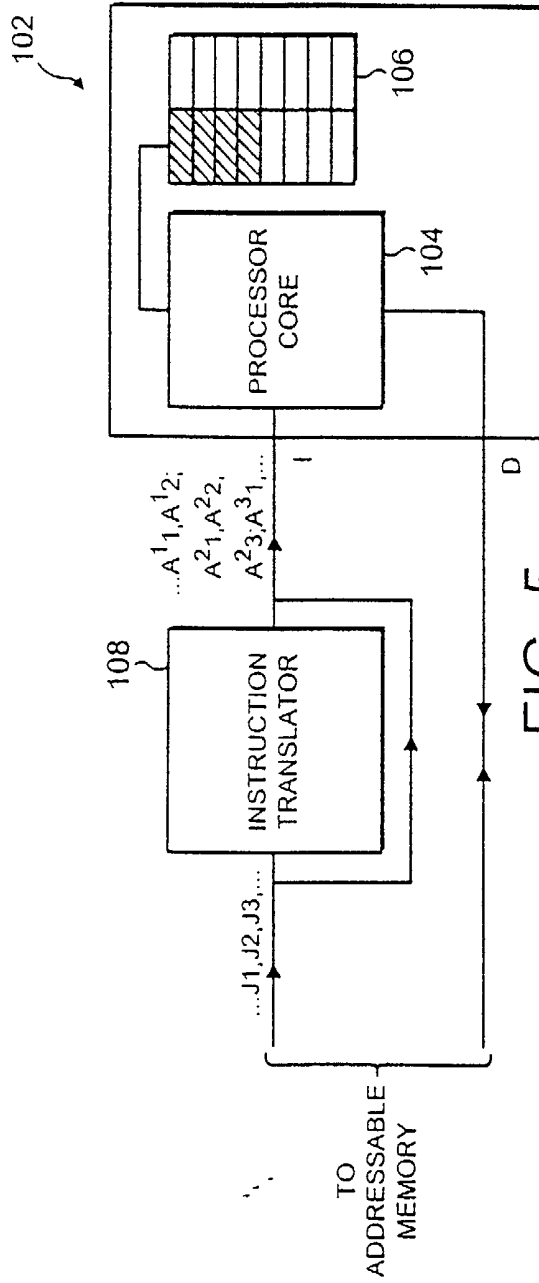

FIG. 5

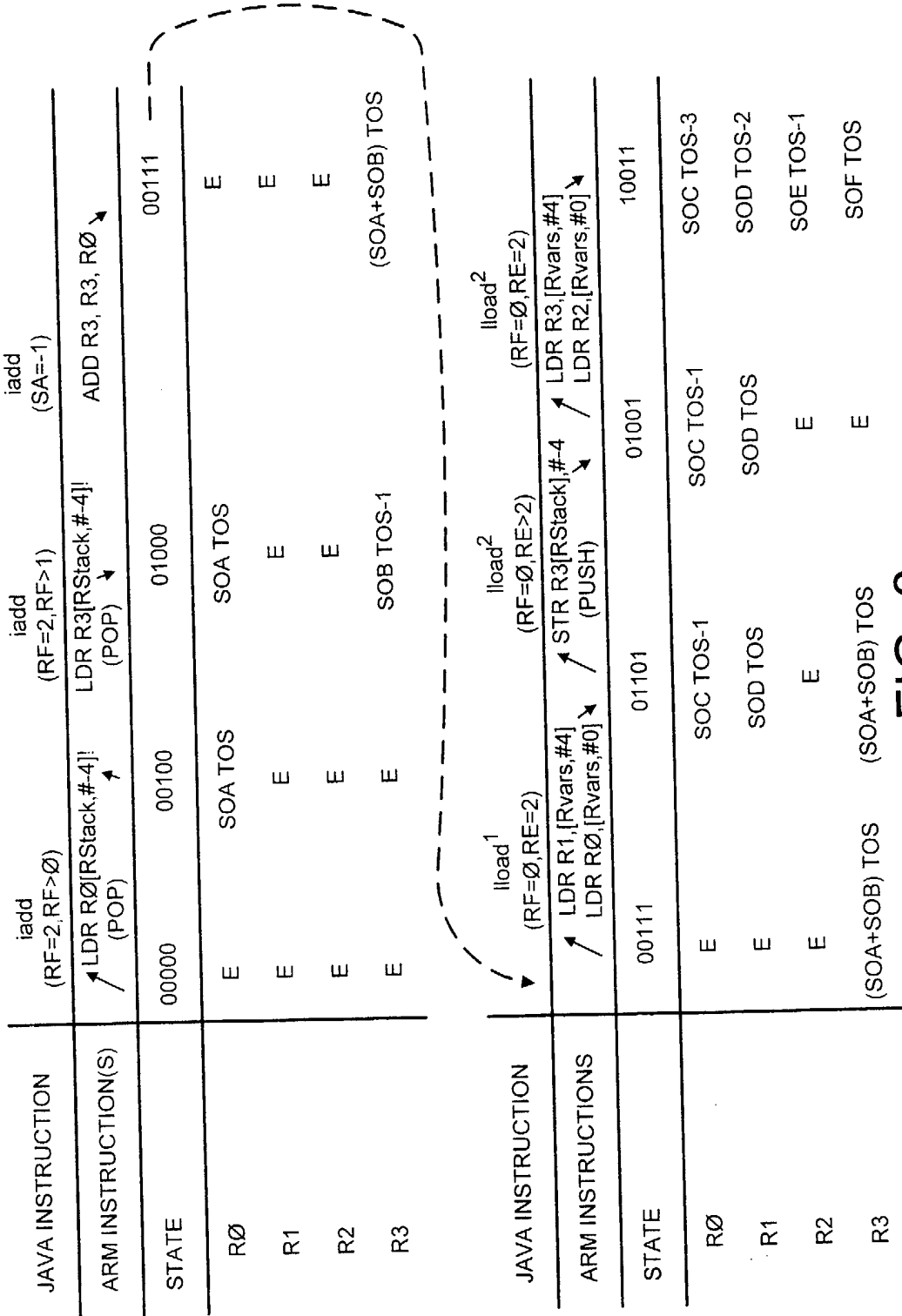

FIG. 6

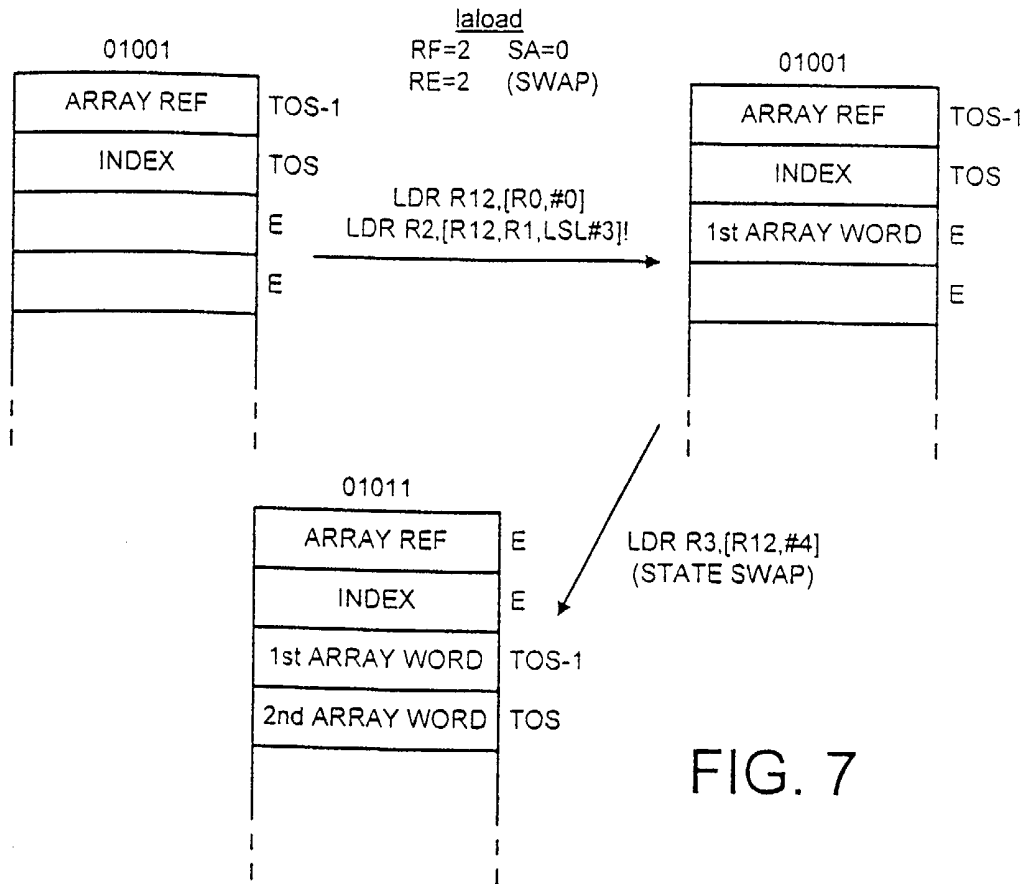

FIG. 7

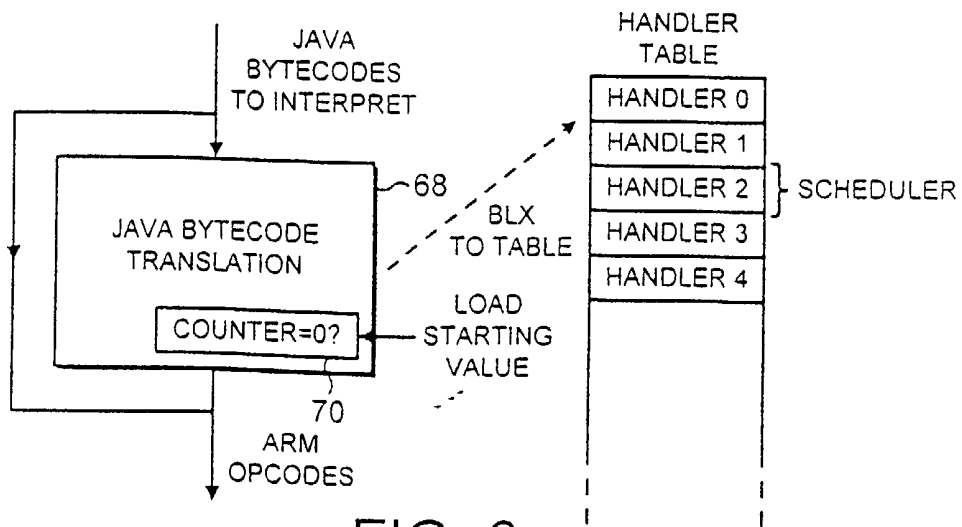

FIG. 9

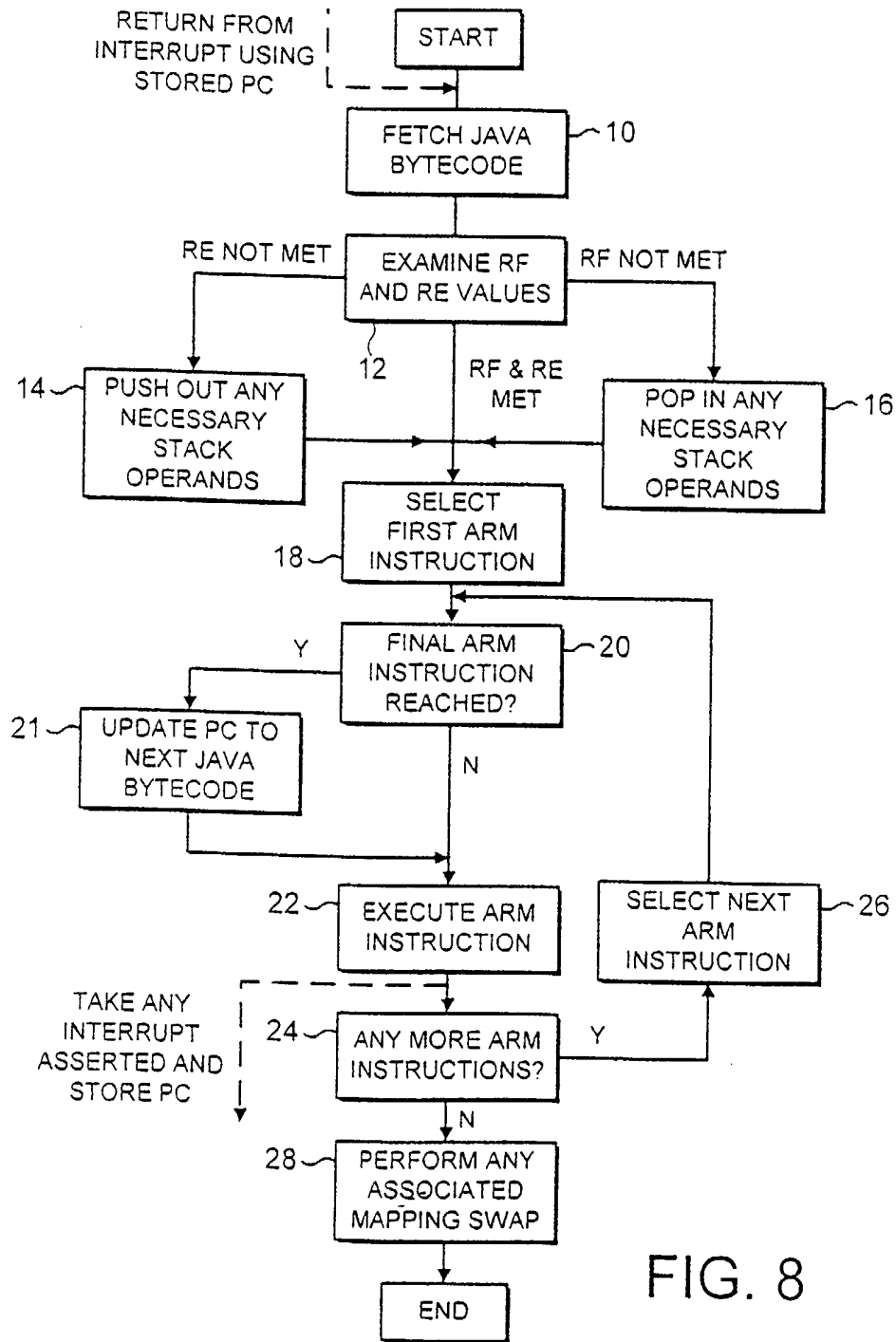

FIG. 8

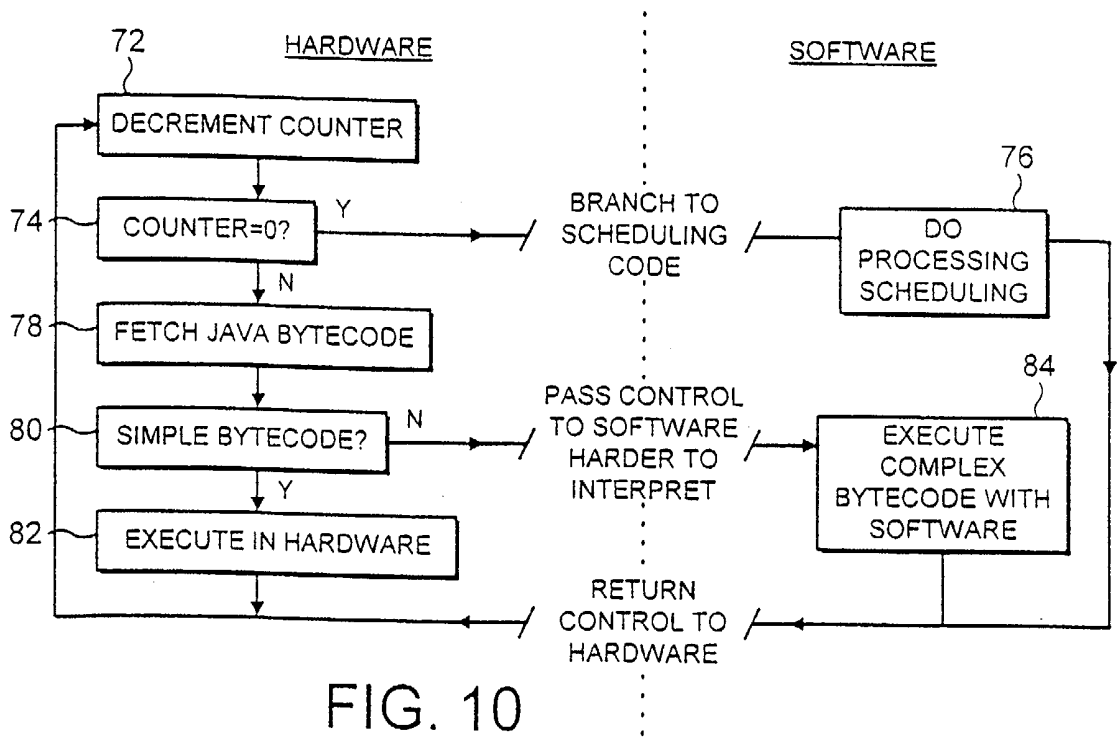

FIG. 10

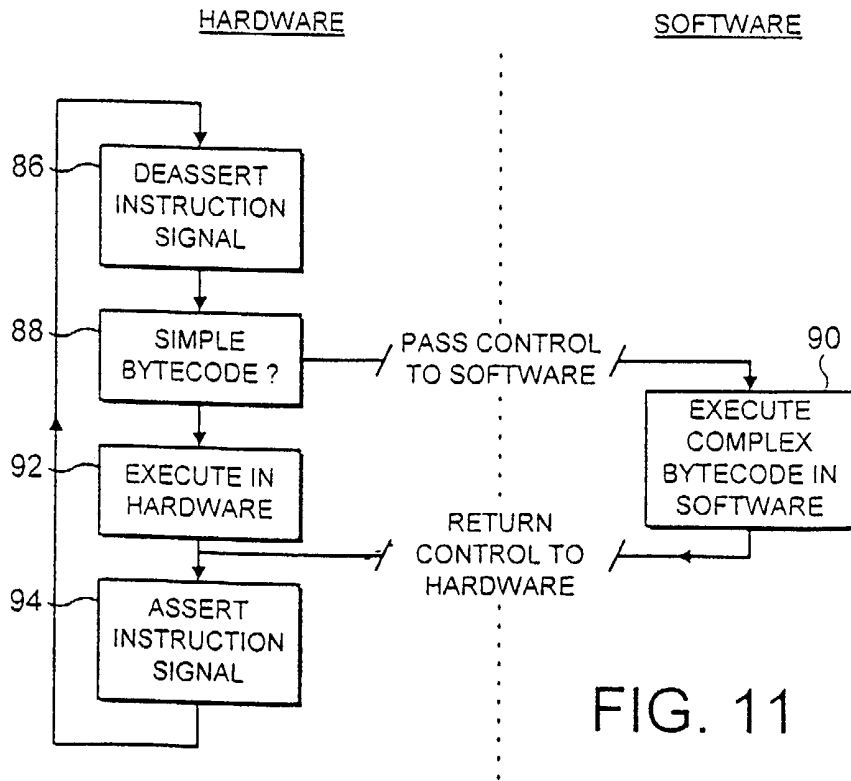
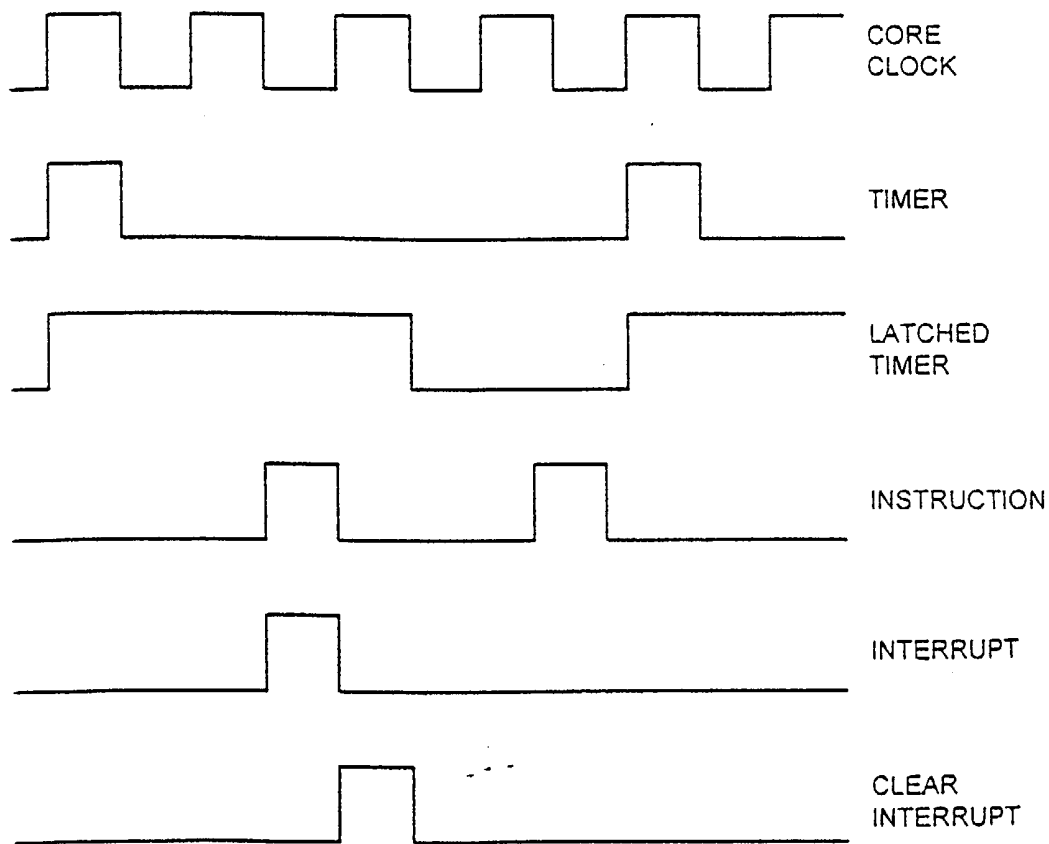
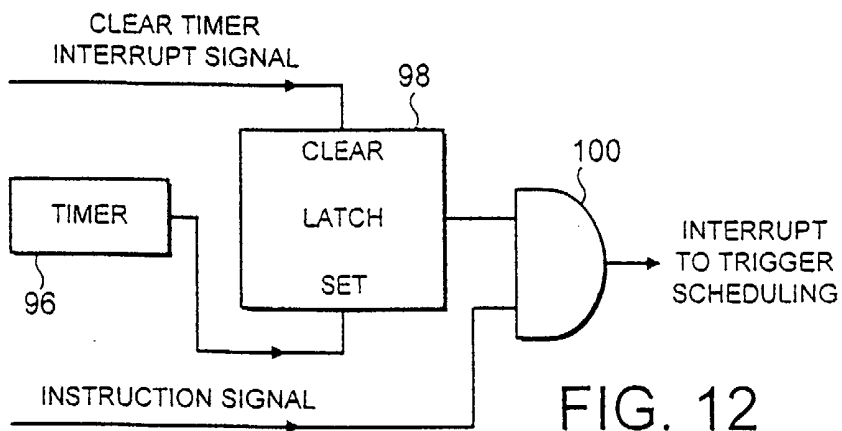

FIG. 11



SCHEDULING CONTROL WITHIN A SYSTEM HAVING MIXED HARDWARE
AND SOFTWARE BASED INSTRUCTION EXECUTION

5

This invention relates to the field of data processing systems. More particular, this invention relates to data processing systems having both a hardware based instruction execution unit and a software based instruction execution unit and in which it is desired to perform scheduling operations.

10

Within modern data processing systems the ability to reliably perform scheduling between tasks or threads is an important capability. Multitasking operating systems require processing resources to be shared between several different programs that may be simultaneously active and multithreaded computer programs similarly require processing resources to be shared between different active threads. It is known to control processing operations using a counter based approach whereby program instructions being executed are counted and a scheduling operation initiated each time a predetermined program instruction count level is reached. An alternative approach is to adopt timer based scheduling in which a scheduling operation is initiated at a regular time interval in a manner similar to servicing an interrupt request.

20

In order to provide support for execution of higher level computer program languages, it is known to use mixed hardware based execution units and software based execution units. Simple instructions within a hardware based execution unit may be executed under control of that hardware based execution unit, whereas more complex program instructions trigger the execution of a software routine, typically written in a low level directly executable program language, which interprets the complex instructions. Whilst such systems are able to provide comprehensive and yet relatively high speed execution of high level program instructions, they pose difficulties in also supporting scheduling.

30

A simple timer based scheduling approach may suffer from the disadvantage that scheduling operations may be inappropriately triggered at points part way through the software interpretation of a complex program instruction in a manner that could cause a loss of data integrity should an inappropriate context switch occur. Counter based scheduling systems suffer from the disadvantage of the need to provide for the exchange of counter

35

values between hardware executed program instructions and software executed program instructions. This represents a disadvantageous overhead.

Examples of known systems for translation between instruction sets and other background information may be found in the following: US-A-5,805,895; US-A-3,955,180; US-A-5,970,242; US-A-5,619,665; US-A-5,826,089; US-A-5,925,123; US-A-5,875,336; US-A-5,937,193; US-A-5,953,520; US-A-6,021,469; US-A-5,568,646; US-A-5,758,115; IBM Technical Disclosure Bulletin, March 1988, pp308-309, "System/370 Emulator Assist Processor For a Reduced Instruction Set Computer"; IBM Technical Disclosure Bulletin, July 10 1986, pp548-549, "Full Function Series/1 Instruction Set Emulator"; IBM Technical Disclosure Bulletin, March 1994, pp605-606, "Real-Time CISC Architecture HW Emulator On A RISC Processor"; IBM Technical Disclosure Bulletin, March 1998, p272, "Performance Improvement Using An EMULATION Control Block"; IBM Technical Disclosure Bulletin, January 1995, pp537-540, "Fast Instruction Decode For Code Emulation on Reduced 15 Instruction Set Computer/Cycles Systems"; IBM Technical Disclosure Bulletin, February 1993, pp231-234, "High Performance Dual Architecture Processor"; IBM Technical Disclosure Bulletin, August 1989, pp40-43, "System/370 I/O Channel Program Channel Command Word Prefetch"; IBM Technical Disclosure Bulletin, June 1985, pp305-306, "Fully Microcode-Controlled Emulation Architecture"; IBM Technical Disclosure Bulletin, 20 March 1972, pp3074-3076, "Op Code and Status Handling For Emulation"; IBM Technical Disclosure Bulletin, August 1982, pp954-956, "On-Chip Microcoding of a Microprocessor With Most Frequently Used Instructions of Large System and Primitives Suitable for Coding Remaining Instructions"; IBM Technical Disclosure Bulletin, April 1983, pp5576-5577, "Emulation Instruction"; the book ARM System Architecture by S Furber and the book 25 Computer Architecture: A Quantitative Approach by Hennessy and Patterson.

The ability to reliably and efficiently support scheduling within mixed hardware and software based instruction execution systems is strongly desirable.

30 Viewed from one aspect the present invention provides apparatus for processing data operable to execute operations specified in a stream of program instructions, said apparatus comprising:

a hardware based instruction execution unit operable to execute program instructions;
and

a software based instruction execution unit operable to execute program instructions;
wherein

program instructions to be executed are sent to said hardware based execution unit for execution;

5 program instructions received by said hardware based execution unit for which execution is not supported by said hardware based execution unit are forwarded to said software based execution unit for execution with control being returned to said hardware based execution unit for a next program instruction to be executed; and

10 said hardware based execution unit includes scheduling support logic operable to generate a scheduling signal for triggering a scheduling operation to be performed between program instructions irrespective of whether a preceding program instruction was executed by said hardware based execution unit or said software based execution unit.

The invention simplifies the provision of scheduling support by providing a system in
15 which program instructions are sent to the hardware based instruction execution unit and forwarded from there to the software based instruction execution unit if they cannot be dealt with by the hardware based instruction execution unit. In this way, by routing all the program instructions through the hardware based instruction execution unit, this unit is able to keep track of the execution of instructions and accordingly generate a scheduling signal for
20 triggering a scheduling operation irrespective of whether the preceding instructions have been executed by hardware or software.

In one preferred embodiment the scheduling support logic within the hardware based instruction execution unit includes a counter that can count program instructions executed by
25 both the hardware and the software based approaches and generate an appropriate scheduling signal to trigger a scheduling operation when a predetermined count value is reached.

Preferably the count value needed to trigger a scheduling operation may be user programmed to fine-tune the scheduling operation concerned, or in some embodiments
30 provide a debugging tool by combining a debugging operation with a scheduling operation in a manner that could, if desired, support single step debugging at one extreme.

In an alternative preferred embodiment a timer based approach may be used with the signal generated by a timer being logically combined ("qualified") with the scheduling signal

generated within the hardware based instruction execution unit so as to ensure that scheduling operations are started at safe points between the execution of program instructions.

5 The invention is particularly useful in embodiments in which the hardware based instruction execution unit is a hardware instruction translator and the software based instruction execution unit is a software interpreter. The use of hardware instruction translation in combination with software based instruction interpretation provides accelerated execution of high level program instructions whilst maintaining comprehensive support for the more complex operations that may be specified within such high level program
10 instructions.

The instruction translation and interpretation operations could be simple, but often require multiple lower level operations to be performed and in this context the accurate control of points at which scheduling operations may be triggered is particularly significant.
15

Whilst the program instruction language within which scheduling is being supported could take many different forms, the invention is particularly well suited to embodiments in which the program is a Java Virtual Machine instruction program involving a mix of Java bytecode hardware translation and Java bytecode software interpretation;
20

Embodiments of the invention will now be described, by way of example only, with reference to the accompanying drawings in which:

25 Figures 1 and 2 schematically represent example instruction pipeline arrangements;

Figure 3 illustrates in more detail a fetch stage arrangement;

30 Figure 4 schematically illustrates the reading of variable length non-native instructions from within buffered instruction words within the fetch stage;

Figure 5 schematically illustrates a data processing system for executing both processor core native instructions and instructions requiring translation;

Figure 6 schematically illustrates, for a sequence of example instructions and states the contents of the registers used for stack operand storage, the mapping states and the relationship between instructions requiring translation and native instructions;

5 Figure 7 schematically illustrates the execution of a non-native instruction as a sequence of native instructions;

Figure 8 is a flow diagram illustrating the way in which the instruction translator may operate in a manner that preserves interrupt latency for translated instructions;.

10

Figure 9 schematically illustrates the translation of Java bytecodes into ARM opcodes using hardware and software techniques;

Figure 10 schematically illustrates the flow of control between a hardware based translator, a software based interpreter and software based scheduling;

15

Figures 11 and 12 illustrate another way of controlling scheduling operations using a timer based approach; and

Figure 13 is a signal diagram illustrating the signals controlling the operation of the circuit of Figure 12.

20

Figure 1 shows a first example instruction pipeline 30 of a type suitable for use in an ARM processor based system. The instruction pipeline 30 includes a fetch stage 32, a native instruction (ARM/Thumb instructions) decode stage 34, an execute stage 36, a memory access stage 38 and a write back stage 40. The execute stage 36, the memory access stage 38 and the write back stage 40 are substantially conventional. Downstream of the fetch stage 32, and upstream of the native instruction decode stage 34, there is provided an instruction translator stage 42. The instruction translator stage 42 is a finite state machine that translates Java bytecode instructions of a variable length into native ARM instructions. The instruction translator stage 42 is capable of multi-step operation whereby a single Java bytecode instruction may generate a sequence of ARM instructions that are fed along the remainder of the instruction pipeline 30 to perform the operation specified by the Java bytecode instruction. Simple Java bytecode instructions may required only a single ARM instruction to perform their operation, whereas more complicated Java bytecode instructions, or in circumstances

30

where the surrounding system state so dictates, several ARM instructions may be needed to provide the operation specified by the Java bytecode instruction. This multi-step operation takes place downstream of the fetch stage 32 and accordingly power is not expended upon fetching multiple translated ARM instructions or Java bytecodes from a memory system. The
5 Java bytecode instructions are stored within the memory system in a conventional manner such that additional constraints are not provided upon the memory system in order to support the Java bytecode translation operation.

As illustrated, the instruction translator stage 42 is provided with a bypass path. When
10 not operating in an instruction translating mode, the instruction pipeline 30 may bypass the instruction translator stage 42 and operate in an essentially unaltered manner to provide decoding of native instructions.

In the instruction pipeline 30, the instruction translator stage 42 is illustrated as
15 generating translator output signals that fully represent corresponding ARM instructions and are passed via a multiplexer to the native instruction decoder 34. The instruction translator 42 also generates some extra control signals that may be passed to the native instruction decoder 34. Bit space constraints within the native instruction encoding may impose limitations upon the range of operands that may be specified by native instructions. These limitations are not
20 necessarily shared by the non-native instructions. Extra control signals are provided to pass additional instruction specifying signals derived from the non-native instructions that would not be possible to specify within native instructions stored within memory. As an example, a native instruction may only provide a relatively low number of bits for use as an immediate operand field within a native instruction, whereas the non-native instruction may allow an
25 extended range and this can be exploited by using the extra control signals to pass the extended portion of the immediate operand to the native instruction decoder 34 outside of the translated native instruction that is also passed to the native instruction decoder 34.

Figure 2 illustrates a further instruction pipeline 44. In this example, the system is
30 provided with two native instruction decoders 46, 48 as well as a non-native instruction decoder 50. The non-native instruction decoder 50 is constrained in the operations it can specify by the execute stage 52, the memory stage 54 and the write back stage 56 that are provided to support the native instructions. Accordingly, the non-native instruction decoder 50 must effectively translate the non-native instructions into native operations (which may be

a single native operation or a sequence of native operations) and then supply appropriate control signals to the execute stage 52 to carry out these one or more native operations. It will be appreciated that in this example the non-native instruction decoder does not produce signals that form a native instruction, but rather provides control signals that specify native instruction (or extended native instruction) operations. The control signals generated may not match the control signals generated by the native instruction decoders 46, 48.

In operation, an instruction fetched by the fetch stage 58 is selectively supplied to one of the instruction decoders 46, 48 or 50 in dependence upon the particular processing mode using the illustrated demultiplexer.

Figure 3 schematically illustrates the fetch stage of an instruction pipeline in more detail. Fetching logic 60 fetches fixed length instruction words from a memory system and supplies these to an instruction word buffer 62. The instruction word buffer 62 is a swing buffer having two sides such that it may store both a current instruction word and a next instruction word. Whenever the current instruction word has been fully decoded and decoding has progressed onto the next instruction word, then the fetch logic 60 serves to replace the previous current instruction word with the next instruction word to be fetched from memory, i.e. each side of the swing buffer will increment by two in an interleaved fashion the instruction words that they successively store.

In the example illustrated, the maximum instruction length of a Java bytecode instruction is three bytes. Accordingly, three multiplexers are provided that enable any three neighbouring bytes within either side of the word buffer 62 to be selected and supplied to the instruction translator 64. The word buffer 62 and the instruction translator 64 are also provided with a bypass path 66 for use when native instructions are being fetched and decoded.

It will be seen that each instruction word is fetched from memory once and stored within the word buffer 62. A single instruction word may have multiple Java bytecodes read from it as the instruction translator 64 performs the translation of Java bytecodes into ARM instructions. Variable length translated sequences of native instructions may be generated without requiring multiple memory system reads and without consuming memory resource or

imposing other constraints upon the memory system as the instruction translation operations are confined within the instruction pipeline.

5 A program counter value is associated with each Java bytecode currently being translated. This program counter value is passed along the stages of the pipeline such that each stage is able, if necessary, to use the information regarding the particular Java bytecode it is processing. The program counter value for a Java bytecode that translates into a sequence of a plurality of ARM instruction operations is not incremented until the final ARM instruction operation within that sequence starts to be executed. Keeping the program counter
10 value in a manner that continues to directly point to the instruction within the memory that is being executed advantageously simplifies other aspects of the system, such as debugging and branch target calculation.

Figure 4 schematically illustrates the reading of variable length Java bytecode
15 instructions from the instruction buffer 62. At the first stage a Java bytecode instruction having a length of one is read and decoded. The next stage is a Java bytecode instruction that is three bytes in length and spans between two adjacent instruction words that have been fetched from the memory. Both of these instruction words are present within the instruction buffer 62 and so instruction decoding and processing is not delayed by this spanning of a
20 variable length instruction between instruction words fetched. Once the three Java bytecodes have been read from the instruction buffer 62, the refill of the earlier fetched of the instruction words may commence as subsequent processing will continue with decoding of Java bytecodes from the following instruction word which is already present.

25 The final stage illustrated in Figure 4 illustrates a second three bytecode instruction being read. This again spans between instruction words. If the preceding instruction word has not yet completed its refill, then reading of the instruction may be delayed by a pipeline stall until the appropriate instruction word has been stored into the instruction buffer 62. In some embodiments the timings may be such that the pipeline never stalls due to this type of
30 behaviour. It will be appreciated that the particular example is a relatively infrequent occurrence as most Java bytecodes are shorter than the examples illustrated and accordingly two successive decodes that both span between instruction words is relatively uncommon. A valid signal may be associated with each of the instruction words within the instruction buffer

62 in a manner that is able to signal whether or not the instruction word has appropriately been refilled before a Java bytecode has been read from it.

Figure 5 shows a data processing system 102 including a processor core 104 and a register bank 106. An instruction translator 108 is provided within the instruction path to translate Java Virtual Machine instructions to native ARM instructions (or control signals corresponding thereto) that may then be supplied to the processor core 104. The instruction translator 108 may be bypassed when native ARM instructions are being fetched from the addressable memory. The addressable memory may be a memory system such as a cache memory with further off-chip RAM memory. Providing the instruction translator 108 downstream of the memory system, and particularly the cache memory, allows efficient use to be made of the storage capacity of the memory system since dense instructions that require translation may be stored within the memory system and only expanded into native instructions immediately prior to being passed to the processor core 104.

The register bank 106 in this example contains sixteen general purpose 32-bit registers, of which four are allocated for use in storing stack operands, i.e. the set of registers for storing stack operands is registers R0, R1, R2 and R3.

The set of registers may be empty, partly filled with stack operands or completely filled with stack operands. The particular register that currently holds the top of stack operand may be any of the registers within the set of registers. It will thus be appreciated that the instruction translator may be in any one of seventeen different mapping states corresponding to one state when all of the registers are empty and four groups of four states each corresponding to a respective different number of stack operands being held within the set of registers and with a different register holding the top of stack operand. Table 1 illustrates the seventeen different states of the state mapping for the instruction translator 108. It will be appreciated that with a different number of registers allocated for stack operand storage, or as a result of constraints that a particular processor core may have in the way it can manipulate data values held within registers, the mapping states can vary considerably depending upon the particular implementation and Table 1 is only given as an example of one particular implementation.

	R0 = EMPTY			
	R1 = EMPTY			
	R2 = EMPTY			
5	R3 = EMPTY			
	STATE 00100	STATE 01000	STATE 01100	STATE 10000
	R0 = TOS	R0 = TOS	R0 = TOS	R0 = TOS
10	R1 = EMPTY	R1 = EMPTY	R1 = EMPTY	R1 = TOS-3
	R2 = EMPTY	R2 = EMPTY	R2 = TOS-2	R2 = TOS-2
	R3 = EMPTY	R3 = TOS-1	R3 = TOS-1	R3 = TOS-1
	STATE 00101	STATE 01001	STATE 01101	STATE 10001
15	R0 = EMPTY	R0 = TOS-1	R0 = TOS-1	R0 = TOS-1
	R1 = TOS	R1 = TOS	R1 = TOS	R1 = TOS
	R2 = EMPTY	R2 = EMPTY	R2 = EMPTY	R2 = TOS-3
	R3 = EMPTY	R3 = EMPTY	R3 = TOS-2	R3 = TOS-2
20	STATE 00110	STATE 01010	STATE 01110	STATE 10010
	R0 = EMPTY	R0 = EMPTY	R0 = TOS-2	R0 = TOS-2
	R1 = EMPTY	R1 = TOS-1	R1 = TOS-1	R1 = TOS-1
25	R2 = TOS	R2 = TOS	R2 = TOS	R2 = TOS
	R3 = EMPTY	R3 = EMPTY	R3 = EMPTY	R3 = TOS-3
	STATE 00111	STATE 01011	STATE 01111	STATE 10011
30	R0 = EMPTY	R0 = EMPTY	R0 = EMPTY	R0 = TOS-3
	R1 = EMPTY	R1 = EMPTY	R1 = TOS-2	R1 = TOS-2
	R2 = EMPTY	R2 = TOS-1	R2 = TOS-1	R2 = TOS-1
	R3 = TOS	R3 = TOS	R3 = TOS	R3 = TOS
35	TABLE 1			

Within Table 1 it may be observed that the first three bits of the state value indicate the number of non-empty registers within the set of registers. The final two bits of the state value indicate the register number of the register holding the top of stack operand. In this way, the state value may be readily used to control the operation of a hardware translator or a software translator to take account of the currently occupancy of the set of registers and the current position of the top of stack operand.

As illustrated in Figure 5 a stream of Java bytecodes J1, J2, J3 is fed to the instruction translator 108 from the addressable memory system. The instruction translator 108 then outputs a stream of ARM instructions (or equivalent control signals, possibly extended) dependent upon the input Java bytecodes and the instantaneous mapping state of the instruction translator 8, as well as other variables. The example illustrated shows Java bytecode J1 being mapped to ARM instructions A¹₁ and A¹₂. Java bytecode J2 maps to

ARM instructions A²1, A²2 and A²3. Finally, Java bytecode J3 maps to ARM instruction A³1. Each of the Java bytecodes may require one or more stack operands as inputs and may produce one or more stack operands as an output. Given that the processor core 104 in this example is an ARM processor core having a load/store architecture whereby only data values held within registers may be manipulated, the instruction translator 108 is arranged to generate ARM instructions that, as necessary, fetch any required stack operands into the set of registers before they are manipulated or store to addressable memory any currently held stack operands within the set of registers to make room for result stack operands that may be generated. It will be appreciated that each Java bytecode may be considered as having an associated “require full” value indicating the number of stack operands that must be present within the set of registers prior to its execution together with a “require empty” value indicating the number of empty registers within the set of registers that must be available prior to execution of the ARM instructions representing the Java opcode.

Table 2 illustrates the relationship between initial mapping state values, require full values, final state values and associated ARM instructions. The initial state values and the final state values correspond to the mapping states illustrated in Table 1. The instruction translator 108 determines a require full value associated with the particular Java bytecode (opcode) it is translating. The instruction translator (108), in dependence upon the initial mapping state that it has, determines whether or not more stack operands need to be loaded into the set of registers prior to executing the Java bytecode. Table 1 shows the initial states together with tests applied to the require full value of the Java bytecode that are together applied to determine whether a stack operand needs to be loaded into the set of registers using an associated ARM instruction (an LDR instruction) as well as the final mapping state that will be adopted after such a stack cache load operation. In practice, if more than one stack operand needs to be loaded into the set of registers prior to execution of the Java bytecode, then multiple mapping state transitions will occur, each with an associated ARM instruction loading a stack operand into one of the registers of the set of registers. In different embodiments it may be possible to load multiple stack operands in a single state transition and accordingly make mapping state changes beyond those illustrated in Table 2.

INITIAL STATE	REQUIRE FULL	FINAL STATE	ACTIONS
00000	>0	00100	LDR R0, [Rstack, #-4]!
00100	>1	01000	LDR R3, [Rstack, #-4]!
01001	>2	01101	LDR R3, [Rstack, #-4]!

	01110	>3	10010	LDR R3, [Rstack, #-4]!
	01111	>3	10011	LDR R0, [Rstack, #-4]!
	01100	>3	10000	LDR R1, [Rstack, #-4]!
	01101	>3	10001	LDR R2, [Rstack, #-4]!
5	01010	>2	01110	LDR R0, [Rstack, #-4]!
	01011	>2	01111	LDR R1, [Rstack, #-4]!
	01000	>2	01100	LDR R2, [Rstack, #-4]!
	00110	>1	01010	LDR R1, [Rstack, #-4]!
	00111	>1	01011	LDR R2, [Rstack, #-4]!
10	00101	>1	01001	LDR R0, [Rstack, #-4]!

TABLE 2

As will be seen from Table 2, a new stack operand loaded into the set of registers storing stack operands will form a new top of stack operand and this will be loaded into a particular one of the registers within the set of registers depending upon the initial state.

Table 3 in a similar manner illustrates the relationship between initial state, require empty value, final state and an associated ARM instruction for emptying a register within the set of registers to move between the initial state and the final state if the require empty value of a particular Java bytecode indicates that it is necessary given the initial state before the Java bytecode is executed. The particular register values stored off to the addressable memory with an STR instruction will vary depending upon which of the registers is the current top of stack operand.

	INITIAL STATE	REQUIRE EMPTY	FINAL STATE	ACTIONS
	00100	>3	00000	STR R0, [Rstack], #4
30	01001	>2	00101	STR R0, [Rstack], #4
	01110	>1	01010	STR R0, [Rstack], #4
	10011	>0	01111	STR R0, [Rstack], #4
	10000	>0	01100	STR R1, [Rstack], #4
	10001	>0	01101	STR R2, [Rstack], #4
35	10010	>0	01110	STR R3, [Rstack], #4
	01111	>1	01011	STR R1, [Rstack], #4
	01100	>1	01000	STR R2, [Rstack], #4
	01101	>1	01001	STR R3, [Rstack], #4
	01010	>2	00110	STR R1, [Rstack], #4
40	01011	>2	00111	STR R2, [Rstack], #4
	01000	>2	00100	STR R3, [Rstack], #4
	00110	>3	00000	STR R2, [Rstack], #4
	00111	>3	00000	STR R3, [Rstack], #4
45	00101	>3	00000	STR R1, [Rstack], #4

TABLE 3

It will be appreciated that in the above described example system the require full and require empty conditions are mutually exclusive, that is to say only one of the require full or require empty conditions can be true at any given time for a particular Java bytecode which the instruction translator is attempting to translate. The instruction templates used by the instruction translator 108 together with the instructions it is chosen to support with the hardware instruction translator 108 are selected such that this mutually exclusive requirement may be met. If this requirement were not in place, then the situation could arise in which a particular Java bytecode required a number of input stack operands to be present within the set of registers that would not allow sufficient empty registers to be available after execution of the instruction representing the Java bytecode to allow the results of the execution to be held within the registers as required.

It will be appreciated that a given Java bytecode will have an overall nett stack action representing the balance between the number of stack operands consumed and the number of stack operands generated upon execution of that Java bytecode. Since the number of stack operands consumed is a requirement prior to execution and the number of stack operands generated is a requirement after execution, the require full and require empty values associated with each Java bytecode must be satisfied prior to execution of that bytecode even if the nett overall action would in itself be met. Table 4 illustrates the relationship between an initial state, an overall stack action, a final state and a change in register use and relative position of the top of stack operand (TOS). It may be that one or more of the state transitions illustrated in Table 2 or Table 3 need to be carried out prior to carrying out the state transitions illustrated in Table 4 in order to establish the preconditions for a given Java bytecode depending on the require full and require empty values of the Java bytecode.

25

	INITIAL STATE	STACK ACTION	FINAL STATE	ACTIONS
	00000	+1	00101	R1 <- TOS
30	00000	+2	01010	R1 <- TOS-1, R2 <- TOS
	00000	+3	01111	R1 <- TOS-2, R2 <- TOS-1, R3 <- TOS
	00000	+4	10000	R0 <- TOS, R1 <- TOS-3, R2 <- TOS-2, R3 <- TOS-1
	00100	+1	01001	R1 <- TOS
35	00100	+2	01110	R1 <- TOS-1, R2 <- TOS
	00100	+3	10011	R1 <- TOS-2, R2 <- TOS-1, R3 <- TOS
	00100	-1	00000	R0 <- EMPTY
	01001	+1	01110	R2 <- TOS
40	01001	+2	10011	R2 <- TOS-1, R3 <- TOS
	01001	-1	00100	R1 <- EMPTY

	01001	-2	00000	R0 <- EMPTY, R1 <- EMPTY	
	01110	+1	10011	R3 <- TOS	
	01110	-1	01001	R2 <- EMPTY	
5	01110	-2	00100	R1 <- EMPTY, R2 <- EMPTY	
	01110	-3	00000	R0 <- EMPTY, R1 <- EMPTY, R2 <- EMPTY	
	10011	-1	01110	R3 <- EMPTY	
	10011	-2	01001	R2 <- EMPTY, R3 <- EMPTY	
10	10011	-3	00100	R1 <- EMPTY, R2 <- EMPTY, R3 <- EMPTY	
	10011	-4	00000	R0 <- EMPTY, R1 <- EMPTY, R2 <- EMPTY,	R3 <- EMPTY
	10000	-1	01111	R0 <- EMPTY	
15	10000	-2	01010	R0 <- EMPTY, R3 <- EMPTY	
	10000	-3	00101	R0 <- EMPTY, R2 <- EMPTY, R3 <- EMPTY	
	10000	-4	00000	R0 <- EMPTY, R1 <- EMPTY, R2 <- EMPTY,	R3 <- EMPTY

	10001	-1	01100	R1 <- EMPTY
	10001	-2	01011	R0 <- EMPTY, R1 <- EMPTY
	10001	-3	00110	R0 <- EMPTY, R1 <- EMPTY, R3 <- EMPTY
5	10001	-4	00000	R0 <- EMPTY, R1 <- EMPTY, R2 <- EMPTY, R3 <- EMPTY
	10010	-1	01101	R2 <- EMPTY
	10010	-2	01000	R1 <- EMPTY, R2 <- EMPTY
10	10010	-3	00111	R0 <- EMPTY, R1 <- EMPTY, R2 <- EMPTY
	10010	-4	00000	R0 <- EMPTY, R1 <- EMPTY, R2 <- EMPTY, R3 <- EMPTY
	01111	+1	10000	R0 <- TOS
15	01111	-1	01010	R3 <- EMPTY
	01111	-2	00101	R2 <- EMPTY, R3 <- EMPTY
	01111	-3	00000	R1 <- EMPTY, R2 <- EMPTY, R3 <- EMPTY
	01100	+1	10001	R1 <- TOS
20	01100	-1	01011	R0 <- EMPTY
	01100	-2	00110	R0 <- EMPTY, R3 <- EMPTY
	01100	-3	00000	R0 <- EMPTY, R2 <- EMPTY, R3 <- EMPTY
	01101	+1	10010	R2 <- TOS
25	01101	-1	01000	R1 <- EMPTY
	01101	-2	00111	R0 <- EMPTY, R1 <- EMPTY
	01101	-3	00000	R0 <- EMPTY, R1 <- EMPTY, R3 <- EMPTY
	01010	+1	01111	R3 <- TOS
30	01010	+2	10000	R3 <- TOS-1, R0 <- TOS
	01010	-1	00101	R2 <- EMPTY
	01010	-2	00000	R1 <- EMPTY, R2 <- EMPTY
	01011	+1	01100	R0 <- TOS
35	01011	+2	10001	R0 <- TOS-1, R1 <- TOS
	01011	-1	00110	R3 <- EMPTY
	01011	-2	00000	R2 <- EMPTY, R3 <- EMPTY
	01000	+1	01101	R1 <- TOS
40	01000	+2	10010	R1 <- TOS-1, R2 <- TOS
	01000	-1	00111	R0 <- EMPTY
	01000	-2	00000	R0 <- EMPTY, R3 <- EMPTY
	00110	+1	01011	R3 <- TOS
45	00110	+2	01100	R0 <- TOS, R3 <- TOS-1
	00110	+3	10001	R1 <- TOS, R0 <- TOS-1, R3 <- TOS-2
	00110	-1	00000	R2 <- EMPTY
	00111	+1	01000	R0 <- TOS
50	00111	+2	01101	R0 <- TOS-1, R1 <- TOS
	00111	+3	10010	R0 <- TOS-2, R1 <- TOS-1, R2 <- TOS
	00111	-1	00000	R3 <- EMPTY
	00101	+1	01010	R2 <- TOS
55	00101	+2	01111	R2 <- TOS-1, R3 <- TOS
	00101	+3	10000	R2 <- TOS-2, R3 <- TOS-1, R1 <- TOS
	00101	-1	00000	R1 <- EMPTY

TABLE 4

It will be appreciated that the relationships between states and conditions illustrated in Table 2, Table 3 and Table 4 could be combined into a single state transition table or state diagram, but they have been shown separately above to aid clarity.

5 The relationships between the different states, conditions, and nett actions may be used to define a hardware state machine (in the form of a finite state machine) for controlling this aspect of the operation of the instruction translator 108. Alternatively, these relationships could be modelled by software or a combination of hardware and software.

10 There follows below an example of a subset of the possible Java bytecodes that indicates for each Java bytecode of the subset the associated require full, require empty and stack action values for that bytecode which may be used in conjunction with Tables 2, 3 and 4.

```

15 --- iconst_0
    Operation:      Push int constant
    Stack:          ... =>
20                ..., 0
                    Require-Full = 0
                    Require-Empty = 1
                    Stack-Action = +1
25 --- iadd
    Operation:      Add int
30 Stack:          ..., value1, value2 =>
                    ..., result
                    Require-Full = 2
                    Require-Empty = 0
35 Stack-Action = -1
    --- lload_0
    Operation:      Load long from local variable
40 Stack:          ... =>
                    ..., value.word1, value.word2
                    Require-Full = 0
45 Require-Empty = 2
                    Stack-Action = +2
    --- lastore
50 Operation:      Store into long array

```

```

Stack:      ..., arrayref, index, value.word1, value.word2 =>
            ...

5           Require-Full = 4
            Require-Empty = 0
            Stack-Action = -4

--- land

10          Operation      Boolean AND long

Stack:      ..., value1.word1, value1.word2, value2.word1,
value2.word2 =>
15          ..., result.word1, result.word2

            Require-Full = 4
            Require-Empty = 0
            Stack-Action = -2

20          --- iastore

            Operation:     Store into int array

25          Stack:        ..., arrayref, index, value =>
            ...

            Require-Full = 3
            Require-Empty = 0
            Stack-Action = -3

30          --- ineg

            Operation:     Negate int

35          Stack:        ..., value =>
            ..., result

            Require-Full = 1
            Require-Empty = 0
            Stack-Action = 0

40

```

There also follows example instruction templates for each of the Java bytecode

45 instructions set out above. The instructions shown are the ARM instructions which implement the required behaviour of each of the Java bytecodes. The register field “TOS-3”, “TOS-2”, “TOS-1”, “TOS”, “TOS+1” and “TOS+2” may be replaced with the appropriate register specifier as read from Table 1 depending upon the mapping state currently adopted. The denotation “TOS+n” indicates the Nth register above the register currently storing the top

50 of stack operand starting from the register storing the top of stack operand and counting upwards in register value until reaching the end of the set of registers at which point a wrap is made to the first register within the set of registers.

```

iconst_0      MOV    tos+1, #0
lload_0       LDR    tos+2, [vars, #4]
              LDR    tos+1, [vars, #0]
5
iastore       LDR    Rtmp2, [tos-2, #4]
              LDR    Rtmp1, [tos-2, #0]
              CMP    tos-1, Rtmp2, LSR #5
              BLXCS  Rexc
10            STR    tos, [Rtmp1, tos-1, LSL #2]

lastore       LDR    Rtmp2, [tos-3, #4]
              LDR    Rtmp1, [tos-3, #0]
              CMP    tos-2, Rtmp2, LSR #5
15            BLXCS  Rexc
              STR    tos-1, [Rtmp1, tos-2, LSL #3]!
              STR    tos, [Rtmp1, #4]

iadd          ADD    tos-1, tos-1, tos
20
ineg          RSB    tos, tos, #0

land         AND    tos-2, tos-2, tos
              AND    tos-3, tos-3, tos-1
25

```

An example execution sequence is illustrated below of a single Java bytecode executed by a hardware translation unit 108 in accordance with the techniques described above. The execution sequence is shown in terms of an initial state progressing through a sequence of states dependent upon the instructions being executed, generating a sequence of ARM instructions as a result of the actions being performed on each state transition, the whole having the effect of translating a Java bytecode to a sequence of ARM instructions.

```

Initial state:      00000
Instruction:        iadd (Require-Full=2, Require-Empty=0, Stack-Action=-
35 1)
Condition:         Require-Full>0
State Transition:  00000    >0    00100
ARM Instruction(s):
                    LDR R0, [Rstack, #-4]!
40
Next state:        00100
Instruction:        iadd (Require-Full=2, Require-Empty=0, Stack-Action=-
1)
Condition:         Requite-Full>1
State Transition:  00100    >1    01000
45 ARM Instructions(s):
                    LDR R3, [Rstack, #-4]!

Next state:        01000
Instruction:        iadd (Require-Full=2, Require-Empty=0, Stack-Action=-
50 1)
Condition:         Stack-Action=-1
State Transition:  01000    -1    00111
Instruction template:
                    ADD    tos-1, tos-1, tos
ARM Instructions(s) (after substitution):

```

ADD R3, R3, R0

Next state: 00111

5 Figure 6 illustrates in a different way the execution of a number of further Java
 bytecode instructions. The top portion of Figure 6 illustrates the sequence of ARM
 instructions and changes of mapping states and register contents that occur upon execution of
 an iadd Java bytecode instruction. The initial mapping state is 00000 corresponding to all of
 the registers within the set of registers being empty. The first two ARM instructions
 10 generated serve to POP two stack operands into the registers storing stack operands with the
 top of stack “TOS” register being R0. The third ARM instruction actually performs the add
 operation and writes the result into register R3 (which now becomes the top of stack operand)
 whilst consuming the stack operand that was previously held within register R1, thus
 producing an overall stack action of -1.

15

Processing then proceeds to execution of two Java bytecodes each representing a long
 load of two stack operands. The require empty condition of 2 for the first Java bytecode is
 immediately met and accordingly two ARM LDR instructions may be issued and executed.
 The mapping state after execution of the first long load Java bytecode is 01101. In this state
 20 the set of registers contains only a single empty register. The next Java bytecode long load
 instruction has a require empty value of 2 that is not met and accordingly the first action
 required is a PUSH of a stack operand to the addressable memory using an ARM STR
 instruction. This frees up a register within the set of registers for use by a new stack operand
 which may then be loaded as part of the two following LDR instructions. As previously
 25 mentioned, the instruction translation may be achieved by hardware, software, or a
 combination of the two. Given below is a subsection of an example software interpreter
 generated in accordance with the above described techniques.

30	Interpret	LDRB	Rtmp, [Rjpc, #1]!
		LDR	pc, [pc, Rtmp, lsl #2]
		DCD	0
		...	
		DCD	do_iconst_0 ; Opcode 0x03
		...	
35		DCD	do_lload_0 ; Opcode 0x1e
		...	
		DCD	do_iastore ; Opcode 0x4f
		DCD	do_lastore ; Opcode 0x50
		...	
40		DCD	do_iadd ; Opcode 0x60
		...	

```

DCD    do_ineg      ; Opcode 0x74
...
DCD    do_land     ; Opcode 0x7f
...
5  do_iconst_0    MOV    R0, #0
STR    R0, [Rstack], #4
B      Interpret
do_lload_0      LDMIA  Rvars, {R0, R1}
STMIA  Rstack!, {R0, R1}
10 do_iastore     B      Interpret
LDMDB  Rstack!, {R0, R1, R2}
LDR    Rtmp2, [r0, #4]
LDR    Rtmp1, [r0, #0]
CMP    R1, Rtmp2, LSR #5
15 BCS    ArrayBoundException
STR    R2, [Rtmp1, R1, LSL #2]
B      Interpret
do_lastore     LDMDB  Rstack!, {R0, R1, R2, R3}
LDR    Rtmp2, [r0, #4]
20 LDR    Rtmp1, [r0, #0]
CMP    R1, Rtmp2, LSR #5
BCS    ArrayBoundException
STR    R2, [Rtmp1, R1, LSL #3]!
STR    R3, [Rtmp1, #4]
25 B      Interpret
do_iadd       LDMDB  Rstack!, {r0, r1}
ADD    r0, r0, r1
STR    r0, [Rstack], #4
B      Interpret
30 do_ineg      LDR    r0, [Rstack, #-4]!
RSB    tos, tos, #0
STR    r0, [Rstack], #4
B      Interpret
do_land      LDMDB  Rstack!, {r0, r1, r2, r3}
35 AND    r1, r1, r3
AND    r0, r0, r2
STMIA  Rstack!, {r0, r1}
B      Interpret
40 State_00000_Interpret  LDRB  Rtmp, [Rjpc, #1]!
LDR    pc, [pc, Rtmp, lsl #2]
DCD    0
...
45 DCD    State_00000_do_iconst_0 ; Opcode 0x03
...
DCD    State_00000_do_lload_0 ; Opcode 0x1e
...
DCD    State_00000_do_iastore ; Opcode 0x4f
DCD    State_00000_do_lastore ; Opcode 0x50
50 ...
DCD    State_00000_do_iadd ; Opcode 0x60
...
DCD    State_00000_do_ineg ; Opcode 0x74
...
55 DCD    State_00000_do_land ; Opcode 0x7f
...
State_00000_do_iconst_0 MOV    R1, #0
B      State_00101_Interpret
State_00000_do_lload_0 LDMIA  Rvars, {R1, R2}
60 B      State_01010_Interpret
State_00000_do_iastore LDMDB  Rstack!, {R0, R1, R2}

```

```

LDR Rtmp2, [r0, #4]
LDR Rtmp1, [r0, #0]
CMP R1, Rtmp2, LSR #5
BCS ArrayBoundException
5 STR R2, [Rtmp1, R1, LSL #2]
B State_00000_Interpret
State_00000_do_lastore LDMDB Rstack!, {R0, R1, R2, R3}
LDR Rtmp2, [r0, #4]
LDR Rtmp1, [r0, #0]
10 CMP R1, Rtmp2, LSR #5
BCS ArrayBoundException
STR R2, [Rtmp1, R1, LSL #3]!
STR R3, [Rtmp1, #4]
B State_00000_Interpret
15 State_00000_do_iadd LDMDB Rstack!, {R1, R2}
ADD r1, r1, r2
B State_00101_Interpret
State_00000_do_ineg LDR r1, [Rstack, #-4]!
RSB r1, r1, #0
20 B State_00101_Interpret
State_00000_do_land LDR r0, [Rstack, #-4]!
LDMDB Rstack!, {r1, r2, r3}
AND r2, r2, r0
AND r1, r1, r3
25 B State_01010_Interpret

State_00100_Interpret LDRB Rtmp, [Rjpc, #1]!
LDR pc, [pc, Rtmp, lsl #2]
DCD 0
30 ...
DCD State_00100_do_iconst_0 ; Opcode 0x03
...
DCD State_00100_do_lload_0 ; Opcode 0x1e
...
35 DCD State_00100_do_iastore ; Opcode 0x4f
DCD State_00100_do_lastore ; Opcode 0x50
...
DCD State_00100_do_iadd ; Opcode 0x60
...
40 DCD State_00100_do_ineg ; Opcode 0x74
...
DCD State_00100_do_land ; Opcode 0x7f
...

45 State_00100_do_iconst_0 MOV R1, #0
B State_01001_Interpret
State_00100_do_lload_0 LDMIA Rvars, {r1, R2}
B State_01110_Interpret
State_00100_do_iastore LDMDB Rstack!, {r2, r3}
LDR Rtmp2, [r2, #4]
50 LDR Rtmp1, [r2, #0]
CMP R3, Rtmp2, LSR #5
BCS ArrayBoundException
STR R0, [Rtmp1, R3, lsl #2]
B State_00000_Interpret
55 State_00100_do_lastore LDMDB Rstack!, {r1, r2, r3}
LDR Rtmp2, [r1, #4]
LDR Rtmp1, [r1, #0]
CMP r2, Rtmp2, LSR #5
BCS ArrayBoundException
60 STR r3, [Rtmp1, r2, lsl #3]!
STR r0, [Rtmp1, #4]

```

```

State_00100_do_iadd      B      State_00000_Interpret
                        LDR      r3, [Rstack, #-4]!
                        ADD      r3, r3, r0
5  State_00100_do_ineg    B      State_00111_Interpret
                        RSB      r0, r0, #0
State_00100_do_land      B      State_00100_Interpret
                        LDMDB    Rstack!, {r1, r2, r3}
                        AND      r2, r2, r0
10                      AND      r1, r1, r3
                        B      State_01010_Interpret

State_01000_Interpret    LDRB    Rtmp, [Rjpc, #1]!
                        LDR      pc, [pc, Rtmp, lsl #2]
15                      DCD      0
                        ...
                        DCD      State_01000_do_iconst_0 ; Opcode 0x03
                        ...
                        DCD      State_01000_do_lload_0 ; Opcode 0x1e
20                      ...
                        DCD      State_01000_do_iastore ; Opcode 0x4f
                        DCD      State_01000_do_lastore ; Opcode 0x50
                        ...
                        DCD      State_01000_do_iadd ; Opcode 0x60
25                      ...
                        DCD      State_01000_do_ineg ; Opcode 0x74
                        ...
                        DCD      State_01000_do_land ; Opcode 0x7f
                        ...

State_01000_do_iconst_0 MOV      R1, #0
30                      B      State_01101_Interpret
State_01000_do_lload_0  LDMIA   Rvars, {r1, r2}
                        B      State_10010_Interpret
State_01000_do_iastore  LDR      r1, [Rstack, #-4]!
35                      LDR      Rtmp2, [R3, #4]
                        LDR      Rtmp1, [R3, #0]
                        CMP      r0, Rtmp2, LSR #5
                        BCS      ArrayBoundException
                        STR      r1, [Rtmp1, r0, lsl #2]
40                      B      State_00000_Interpret
State_01000_do_lastore  LDMDB    Rstack!, {r1, r2}
                        LDR      Rtmp2, {r3, #4}
                        LDR      Rtmp1, {R3, #0}
45                      CMP      r0, Rtmp2, LSR #5
                        BCS      ArrayBoundException
                        STR      r1, [Rtmp1, r0, lsl #3]!
                        STR      r2, [Rtmp1, #4]
                        B      State_00000_Interpret
State_01000_do_iadd     ADD      r3, r3, r0
50                      B      State_00111_Interpret
State_01000_do_ineg     RSB      r0, r0, #0
                        B      State_01000_Interpret
State_01000_do_land     LDMDB    Rstack!, {r1, r2}
                        AND      R0, R0, R2
55                      AND      R3, R3, R1
                        B      State_01000_Interpret

State_01100_Interpret   ...
State_10000_Interpret   ...
State_00101_Interpret   ...
60                      State_01001_Interpret ...
State_01101_Interpret   ...

```

```

State_10001_Interpret ...
State_00110_Interpret ...
state_01010_Interpret ...
State_01110_Interpret ...
5 State_10010_Interpret ...
State_00111_Interpret ...
State_01011_Interpret ...
state_01111_Interpret ...
State_10011_Interpret ...

```

10

Figure 7 illustrates a Java bytecode instruction “laload” which has the function of reading two words of data from within a data array specified by two words of data starting at the top of stack position. The two words read from the data array then replace the two words that specified their position and to form the topmost stack entries.

15

In order that the “laload” instruction has sufficient register space for the temporary storage of the stack operands being fetched from the array without overwriting the input stack operands that specify the array and position within the array of the data, the Java bytecode instruction is specified as having a require empty value of 2, i.e. two of the registers within the register bank dedicated to stack operand storage must be emptied prior to executing the ARM instructions emulating the “laload” instruction. If there are not two empty registers when this Java bytecode is encountered, then store operations (STRs) may be performed to PUSH stack operands currently held within the registers out to memory so as to make space for the temporary storage necessary and meet the require empty value for the instruction.

25

The instruction also has a require full value of 2 as the position of the data is specified by an array location and an index within that array as two separate stack operands. The drawing illustrates the first state as already meeting the require full and require empty conditions and having a mapping state of “01001”. The “laload” instruction is broken down into three ARM instructions. The first of these loads the array reference into a spare working register outside of the set of registers acting as a register cache of stack operands. The second instruction then uses this array reference in conjunction with an index value within the array to access a first array word that is written into one of the empty registers dedicated to stack operand storage.

35

It is significant to note that after the execution of the first two ARM instructions, the mapping state of the system is not changed and the top of stack pointer remains where it started with the registers specified as empty still being so specified.

The final instruction within the sequence of ARM instructions loads the second array word into the set of registers for storing stack operands. As this is the final instruction, if an interrupt does occur during it, then it will not be serviced until after the instruction completes and so it is safe to change the input state with this instruction by a change to the mapping state of the registers storing stack operands. In this example, the mapping state changes to “01011” which places the new top of stack pointer at the second array word and indicates that the input variables of the array reference and index value are now empty registers, i.e. marking the registers as empty is equivalent to removing the values they held from the stack.

It will be noted that whilst the overall stack action of the “laload” instruction has not changed the number of stack operands held within the registers, a mapping state swap has nevertheless occurred. The change of mapping state performed upon execution of the final operation is hardwired into the instruction translator as a function of the Java bytecode being translated and is indicated by the “swap” parameter shown as a characteristic of the “laload” instruction.

Whilst the example of this drawing is one specific instruction, it will be appreciated that the principles set out may be extended to many different Java bytecode instructions that are emulated as ARM instructions or other types of instruction.

Figure 8 is a flow diagram schematically illustrating the above technique. At step 10 a Java bytecode is fetched from memory. At step 12 the require full and require empty values for that Java bytecode are examined. If either of the require empty or require full conditions are not met, then respective PUSH and POP operations of stack operands (possibly multiple stack operands) may be performed with steps 14 and 16. It is will be noted that this particular system does not allow the require empty and require full conditions to be simultaneously unmet. Multiple passes through steps 14 and 16 may be required until the condition of step 12 is met.

At step 18, the first ARM instruction specified within the translation template for the Java bytecode concerned is selected. At step 20, a check is made as to whether or not the selected ARM instruction is the final instruction to be executed in the emulation of the Java bytecode fetched at step 10. If the ARM instruction being executed is the final instruction,

then step 21 serves to update the program counter value to point to the next Java bytecode in the sequence of instructions to be executed. It will be understood that if the ARM instruction is the final instruction, then it will complete its execution irrespective of whether or not an interrupt now occurs and accordingly it is safe to update the program counter value to the next
 5 Java bytecode and restart execution from that point as the state of the system will have reached that matching normal, uninterrupted, full execution of the Java bytecode. If the test at step 20 indicates that the final bytecode has not been reached, then updating of the program counter value is bypassed.

10 Step 22 executes the current ARM instruction. At step 24 a test is made as to whether or not there are any more ARM instructions that require executing as part of the template. If there are more ARM instructions, then the next of these is selected at step 26 and processing is returned to step 20. If there are no more instructions, then processing proceeds to step 28 at which any mapping change/swap specified for the Java bytecode concerned is performed in
 15 order to reflect the desired top of stack location and full/empty status of the various registers holding stack operands.

Figure 8 also schematically illustrates the points at which an interrupt if asserted is serviced and then processing restarted after an interrupt. An interrupt starts to be serviced
 20 after the execution of an ARM instruction currently in progress at step 22 with whatever is the current program counter value being stored as a return point with the bytecode sequence. If the current ARM instruction executing is the final instruction within the template sequence, then step 21 will have just updated the program counter value and accordingly this will point to the next Java bytecode (or ARM instruction should an instruction set switch have just been
 25 initiated). If the currently executing ARM instruction is anything other than the final instruction in the sequence, then the program counter value will still be the same as that indicated at the start of the execution of the Java bytecode concerned and accordingly when a return is made, the whole Java bytecode will be re-executed.

30 Figure 9 illustrates a Java bytecode translation unit 68 that receives a stream of Java bytecodes and outputs a translated stream of ARM instructions (or corresponding control signals) to control the action of a processor core. As described previously, the Java bytecode translator 68 translates simple Java bytecodes using instruction templates into ARM instructions or sequences of ARM instructions. When each Java bytecode has been executed, then a counter

value within scheduling control logic 70 is decremented. When this counter value reaches 0, then the Java bytecode translation unit 68 issues an ARM instruction branching to scheduling code that manages scheduling between threads or tasks as appropriate.

5 Whilst simple Java bytecodes are handled by the Java bytecode translation unit 68 itself providing high speed hardware based execution of these bytecodes, bytecodes requiring more complex processing operations are sent to a software interpreter provided in the form of a collection of interpretation routines (examples of a selection of such routines are given earlier in this description). More specifically, the Java bytecode translation unit 68 can determine that the
10 bytecode it has received is not one which is supported by hardware translation and accordingly a branch can be made to an address dependent upon that Java bytecode where a software routine for interpreting that bytecode is found or referenced. This mechanism can also be employed when the scheduling logic 70 indicates that a scheduling operation is needed to yield a branch to the scheduling code.

15 Figure 10 illustrates the operation of the embodiment of Figure 9 in more detail and the split of tasks between hardware and software. All Java bytecodes are received by the Java bytecode translation unit 68 and cause the counter to be decremented at step 72. At step 74 a check is made as to whether or not the counter value has reached 0. If the counter value has
20 reached 0 (counting down from either a predetermined value hardwired into the system or a value that may be user controlled/programmed), then a branch is made to scheduling code at step 76. Once the scheduling code has completed at step 76, control is returned to the hardware and processing proceeds to step 72, where the next Java bytecode is fetched and the counter again decremented. Since the counter reached 0, then it will now roll round to a new, non-zero value.
25 Alternatively, a new value may be forced into the counter as part of the exiting of the scheduling process at step 76.

 If the test at step 74 indicated that the counter did not equal 0, then step 78 fetches the Java bytecode. At step 80 a determination is made as to whether the fetched bytecode is a simple
30 bytecode that may be executed by hardware translation at step 82 or requires more complex processing and accordingly should be passed out for software interpretation at step 84. If processing is passed out to software interpretation, then once this has completed control is returned to the hardware where step 72 decrements the counter again to take account of the fetching of the next Java bytecode.

Figure 11 illustrates an alternative control arrangement. At the start of processing at step 86 an instruction signal (scheduling signal) is deasserted. At step 88, a fetched Java bytecode is examined to see if it is a simple bytecode for which hardware translation is supported. If hardware translation is not supported, then control is passed out to the interpreting software at step 90 which then executes a ARM instruction routine to interpret the Java bytecode. If the bytecode is a simple one for which hardware translation is supported, then processing proceeds to step 92 at which one or more ARM instructions are issued in sequence by the Java bytecode translation unit 68 acting as a form of multi-cycle finite state machine. Once the Java bytecode has been properly executed either at step 90 or at step 92, then processing proceeds to step 94 at which the instruction signal is asserted for a short period prior to being deasserted at step 86. The assertion of the instruction signal indicates to external circuitry that an appropriate safe point has been reached at which a timer based scheduling interrupt could take place without risking a loss of data integrity due to the partial execution of an interpreted or translated instruction.

15

Figure 12 illustrates example circuitry that may be used to respond to the instruction signal generated in Figure 11. A timer 96 periodically generates a timer signal after expiry of a given time period. This timer signal is stored within a latch 98 until it is cleared by a clear timer interrupt signal. The output of the latch 98 is logically combined by an AND gate 100 with the instruction signal asserted at step 94. When the latch is set and the instruction signal is asserted, then an interrupt is generated as the output of the AND gate 100 and is used to trigger an interrupt that performs scheduling operations using the interrupt processing mechanisms provided within the system for standard interrupt processing. Once the interrupt signal has been generated, this in turn triggers the production of a clear timer interrupt signal that clears the latch 98 until the next timer output pulse occurs.

20
25

Figure 13 is a signal diagram illustrating the operation of the circuit of Figure 12. The processor core clock signals occur at a regular frequency. The timer 96 generates timer signals at predetermined periods to indicate that, when safe, a scheduling operation should be initiated. The timer signals are latched. Instruction signals are generated at times spaced apart by intervals that depend upon how quickly a particular Java bytecode was executed. A simple Java bytecode may execute in a single processor core clock cycle, or more typically two or three, whereas a complex Java bytecode providing a high level management type function may take several hundred processor clock cycles before its execution is completed by the software interpreter. In

30

either case, a pending asserted latched timer signal is not acted upon to trigger a scheduling operation until the instruction signal issues indicating that it is safe for the scheduling operation to commence. The simultaneous occurrence of a latched timer signal and the instruction signal triggers the generation of an interrupt signal followed immediately thereafter by a clear signal that clears the latch 98.

5

CLAIMS

1. Apparatus for processing data operable to execute operations specified in a stream of
5 program instructions, said apparatus comprising:
a hardware based instruction execution unit operable to execute program instructions;
and
a software based instruction execution unit operable to execute program instructions;
wherein
10 program instructions to be executed are sent to said hardware based execution unit for
execution;
program instructions received by said hardware based execution unit for which
execution is not supported by said hardware based execution unit are forwarded to said
software based execution unit for execution with control being returned to said hardware
15 based execution unit for a next program instruction to be executed; and
said hardware based execution unit includes scheduling support logic operable to
generate a scheduling signal for triggering a scheduling operation to be performed between
program instructions irrespective of whether a preceding program instruction was executed by
said hardware based execution unit or said software based execution unit.
20
2. Apparatus as claimed in claim 1, wherein said scheduling support logic includes a
counter with a value that is changed in response to a program instruction sent to said hardware
based execution unit.
- 25 3. Apparatus as claimed in claim 2, wherein said counter triggers generation of said
scheduling signal when a predetermined count value is reached.
4. Apparatus as claimed in claim 3, wherein said counter may be programmed to start
from a user programmable start value.
30
5. Apparatus as claimed in claim 3, wherein said counter counts up to said predetermined
value.

6. Apparatus as claimed in claim 3, wherein said counter counts down to said predetermined value.
7. Apparatus as claimed in claim 1, wherein a debug operation is triggered by said scheduling signal.
8. Apparatus as claimed in claim 1, further comprising timer logic operable to generate a timer signal indicative of a time since a last scheduling operation.
9. Apparatus as claimed in claim 8, wherein said scheduling signal is combined with said timer signal to trigger said scheduling operation.
10. Apparatus as claimed in claim 8, wherein a scheduling operation is triggered upon generation of said scheduling signal after said timer signal has reached a predetermined value indicating a predetermined period time since a last scheduling operation has expired.
11. Apparatus as claimed in claim 1, further comprising a processor core operable to execute operations as specified by instructions of a first instruction set.
12. Apparatus as claimed in claim 11, where said hardware based instruction execution unit includes an instruction translator operable to translate instructions of a second instruction set into translator output signals corresponding to instructions of said first instruction set.
13. Apparatus as claimed in claim 12, wherein
at least one instruction of said second instruction set specifies a multi-step operation that requires a plurality of operations that may be specified by instructions of said first instruction set in order to be performed by said processor core; and
said instruction translator is operable to generate a sequence of translator output signals to control said processor core to perform said multi-step operation.
14. Apparatus as claimed in claim 1, wherein said software based execution unit is a software based interpreter.

15. Apparatus as claimed in claim 1, wherein said program instructions are Java Virtual Machine instructions.

16. A method of processing data by executing operations specified in a stream of program instructions, said method comprising the steps of:

5 executing program instructions with a hardware based instruction execution unit; and
executing program instructions with a software based instruction execution unit;

wherein

10 program instructions to be executed are sent to said hardware based execution unit for
execution;

program instructions received by said hardware based execution unit for which
execution is not supported by said hardware based execution unit are forwarded to said
software based execution unit for execution with control being returned to said hardware
based execution unit for a next program instruction to be executed; and

15 said hardware based execution unit generates a scheduling signal for triggering a
scheduling operation to be performed between program instructions irrespective of whether a
preceding program instruction was executed by said hardware based execution unit or said
software based execution unit.



INVESTOR IN PEOPLE

Application No: GB 0024399.8
Claims searched: all

32

Examiner: Russell Maurice
Date of search: 30 August 2001

Patents Act 1977 Search Report under Section 17

Databases searched:

UK Patent Office collections, including GB, EP, WO & US patent specifications, in:

UK Cl (Ed.S): G4A (AFP APM, APX)

Int Cl (Ed.7): G06F (9/445, 9/30, 9/38, 9/455)

Other: Online WPI, EPODOC, PAJ

Documents considered to be relevant:

Category	Identity of document and relevant passage	Relevant to claims
A, E	EP 1102164 A2 Nec (see abstract and abstract fig.)	-
A	WO 99/61982 A1 AMD (see abstract and abstract fig.)	-
A	US 5953741 A Levy (see abstract and abstract fig.)	-

X	Document indicating lack of novelty or inventive step	A	Document indicating technological background and/or state of the art.
Y	Document indicating lack of inventive step if combined with one or more other documents of same category.	P	Document published on or after the declared priority date but before the filing date of this invention.
&	Member of the same patent family	E	Patent document published on or after, but with priority date earlier than, the filing date of this application.