

가 가

가

2

, , , , ,

1a 1c

2

3 3a 3c

2

4

2

4a 4

4b 4

5

3

6a, 6b, 6c 5

7a, 7b, 7c

, ,

*

*

1: 3:

5: 8:

10: 15:

17: 18: 가

23: 31:

가

(jam)

(arc) 23

가

가

1 - 2 - (two - part)

1a

1c

1b

1a

1c

가

(grip)

1a

(2)

(1)가

(3)

가

(5)가

가

(6)

가

(6)

(Allen wrench)

(3a)

가

(6)

가

(6a)

가

separate body) (7)

(3)

(3)

(1)

(2)

(8)가

(1) , 가

(6)

(8)가

1b

(5)
(15a)

(15)

(10)
(17)

가

(5)

가

가

(18)

(5)

(6, 17)가

가

1c

(21

22)

(

)

(22a)

(21, 22)

(21, 22) 가 ,
(23)가 가
(23) 5,346,493 5,
257,993 가
가
2 (31) 1 (31)
(32) (33) , 1a
(32) 가 (33)
34 (35) (36a, 36b,
36c, 36d) , (37
a, 37b) 2 가 (36a, 36b .. 36d) (36
a, 36c) 가 (38) 가 , (40) (3a
3c).

2 (31) , 3c (40)
(40) (40) (35) 3
(40) (42) (41)
(33) (43a, 43a) (46a, 46b 46c, 46d)
(36a 36d) (36a 36d) (41) (46a 46d)
(40) (33)
(4) (32)
(42) ()가 (34)
() (31) (40)
(5)(1a 1c) (34) 20%
- (anchoring)
2 3 가

(50)가 4 (53)
 (55) (60) (40)
 55) 가 (62a, 62b) (62
 a, 62b) (55) 가
 (55) 가
 (33, 53) (35, 52)
 ,가
 4 가 (50) 가 (54) (52) (54)
 4) (binding fit) (53)가 (7) ()가 (5
 1a (53a) (swaging: (型鐵)
 (53) (52) 가
 4a (60) 1
 (62a, 62b)
 (36)
 4b " RS" 가 가
 가 (twist - on cap)
 5 (100) (100)
 (152) (153) (1
 53) (140) 가 가
 가 가
 (140) 가 (145) 가

5

(140) (146) (가) (가) (158) (140)

6a 6b - (140) (153)

6a (140) 6b 5 (153) (158) (140) (146) (153) (146) (158) (159) (149) (140) (가) 6a 6b (ridge)(149a, 159a) (149b, 159b) (6c). (가) (가)

5 6a 가 (flats)(144) 가 (14) 4) (가) (가) (146, 158)

7a 7c (가) (가) (가) 7a 7c (가)

(146) (158) (가) (가) (146) (158) (가) (가) (가)

7a 7c (가) (158) (158, 146) (159, 149)

(158a)가

가

(158a)

(146a)

가

7a 7c

가

(164)

(

)

가

(146, 158)

가

가가

(57)

1.

,

,

가

,

,

가

,

,

가

가

2.

1

,

가

,

3.

1

,

4.

2

,

5.

- 1 , , . ,
- 6.
- 1 , , . ,
- 7.
- , 가 ,
- 가 , - ,
- 8.
- 7 , , -
- 9.
- 8 , , .
- 10.
- 7 , , .
- 11.
- 7 , , .
- 12.
- 7 , , 가 , ,
- 13.
- 7 , , 가 , -
- 14.

21.

19

1a

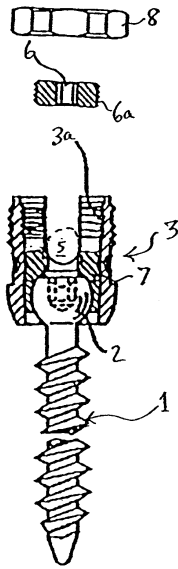

1b

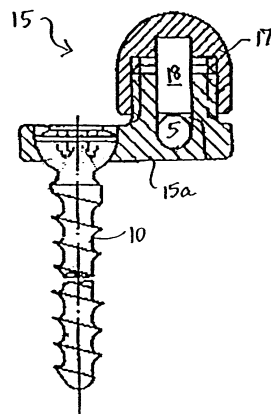

1c



2

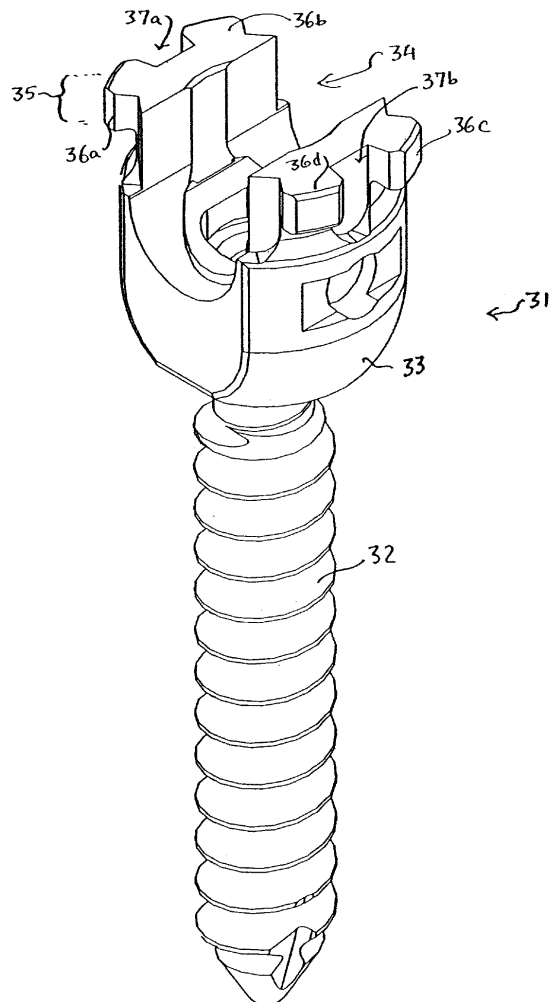

3

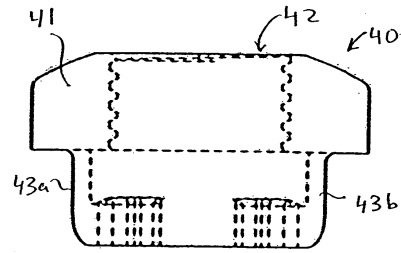

3a

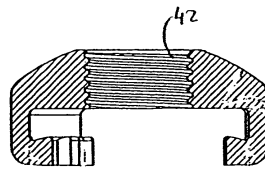

3b

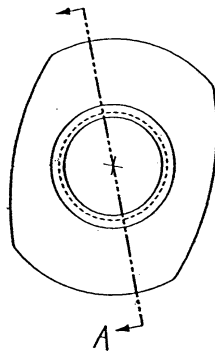

3c

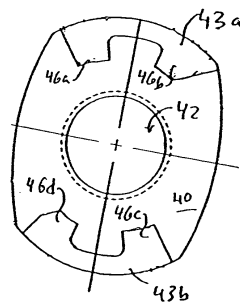

4

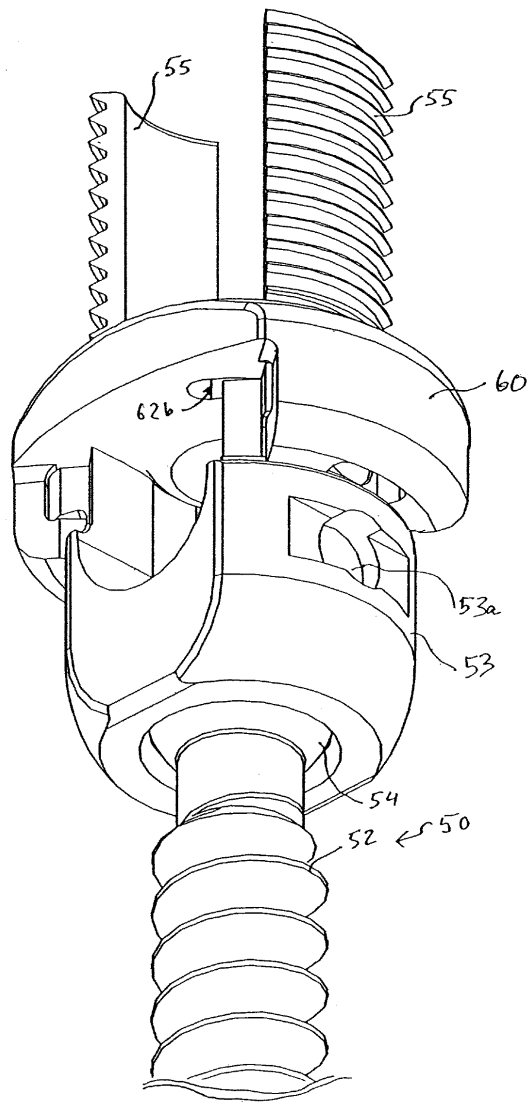

4a

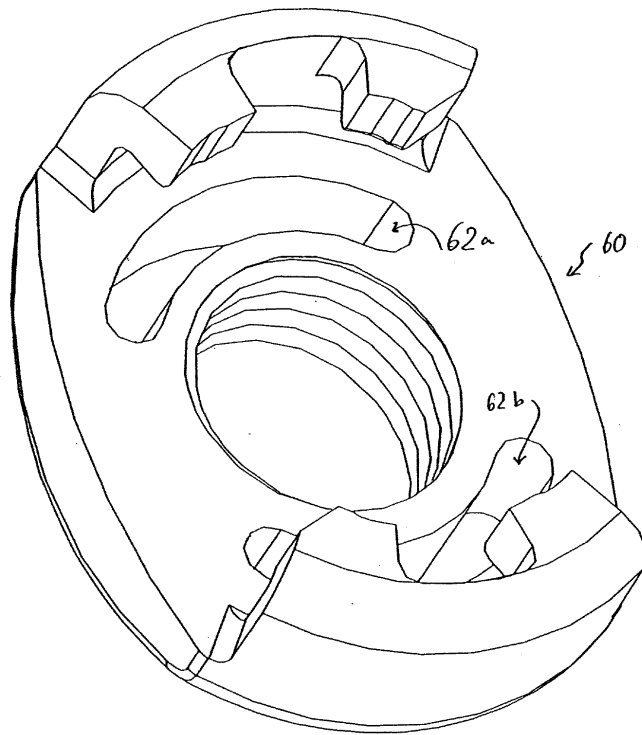

4b

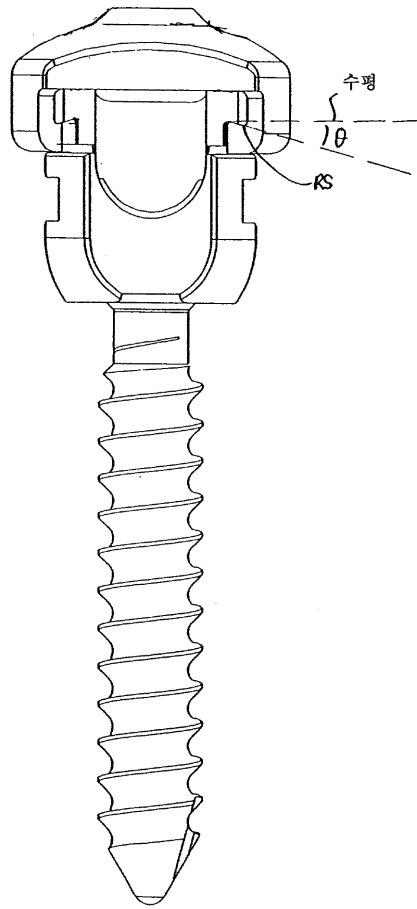

5

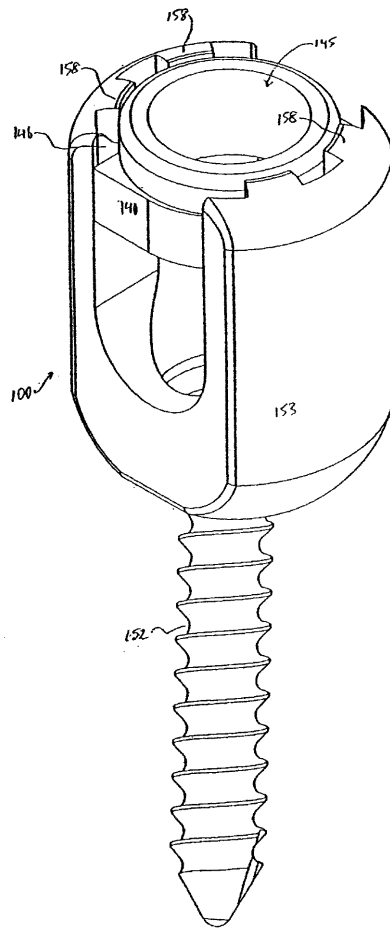

6a

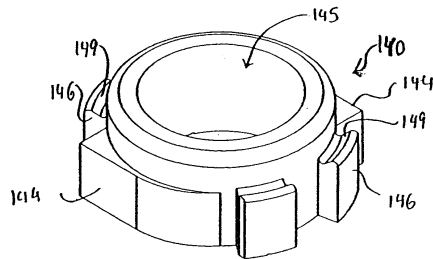

7b

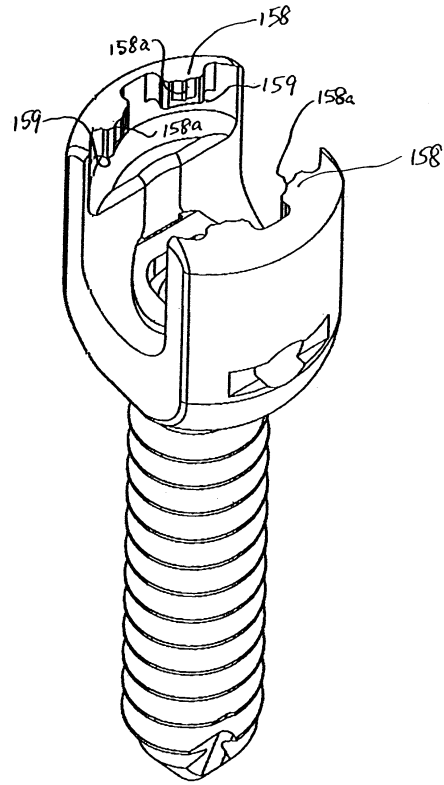

7c

