



US 20080125897A1

(19) **United States**
(12) **Patent Application Publication**
DiGianfilippo et al.

(10) **Pub. No.: US 2008/0125897 A1**
(43) **Pub. Date: May 29, 2008**

(54) **METHOD FOR TRANSFERRING DATA TO A PHARMACEUTICAL COMPOUNDING SYSTEM**

2003, now Pat. No. 7,343,224, Continuation-in-part of application No. 10/335,552, filed on Dec. 31, 2002, now Pat. No. 7,194,336.

(75) Inventors: **Aleandro DiGianfilippo**,
Scottsdale, AZ (US); **Richard S. Pierce**,
Glendale, AZ (US); **Michael Golebiowski**,
West Lafayette, IN (US)

Publication Classification

(51) **Int. Cl.**
G06F 17/00 (2006.01)
(52) **U.S. Cl.** **700/110; 700/239**

Correspondence Address:
RATNERPRESTIA
P O BOX 980
VALLEY FORGE, PA 19482-0980

(57) **ABSTRACT**

A method for use with a data entry system for providing input data to a pharmaceutical compounding device having an associated plurality of source solutions is provided. A first label comprising first indicia defining a desired pharmaceutical compound is generated. The first indicia is then provided to the pharmaceutical compounding device as an input. The pharmaceutical compounding device then prepares a pharmaceutical compound based on the first indicia and generates a second label comprising second indicia indicative of at least the contents of pharmaceutical compound. The first indicia and second indicia are provided to a comparison device where the contents of the actual pharmaceutical compound as indicated by the second indicia are compared to the desired pharmaceutical compound as indicated by the first indicia.

(73) Assignee: **B. BRAUN MEDICAL INC.**,
Bethlehem, PA (US)

(21) Appl. No.: **11/935,546**

(22) Filed: **Nov. 6, 2007**

Related U.S. Application Data

(63) Continuation of application No. 11/003,232, filed on Dec. 3, 2004, now Pat. No. 7,317,967, Continuation-in-part of application No. 10/728,560, filed on Dec. 5,

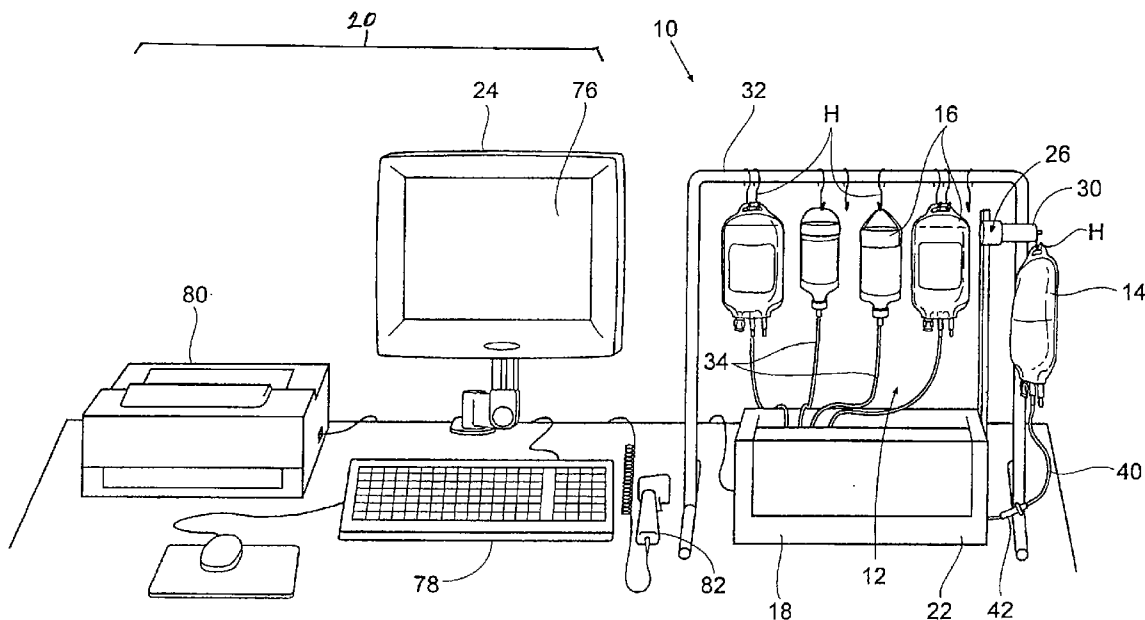

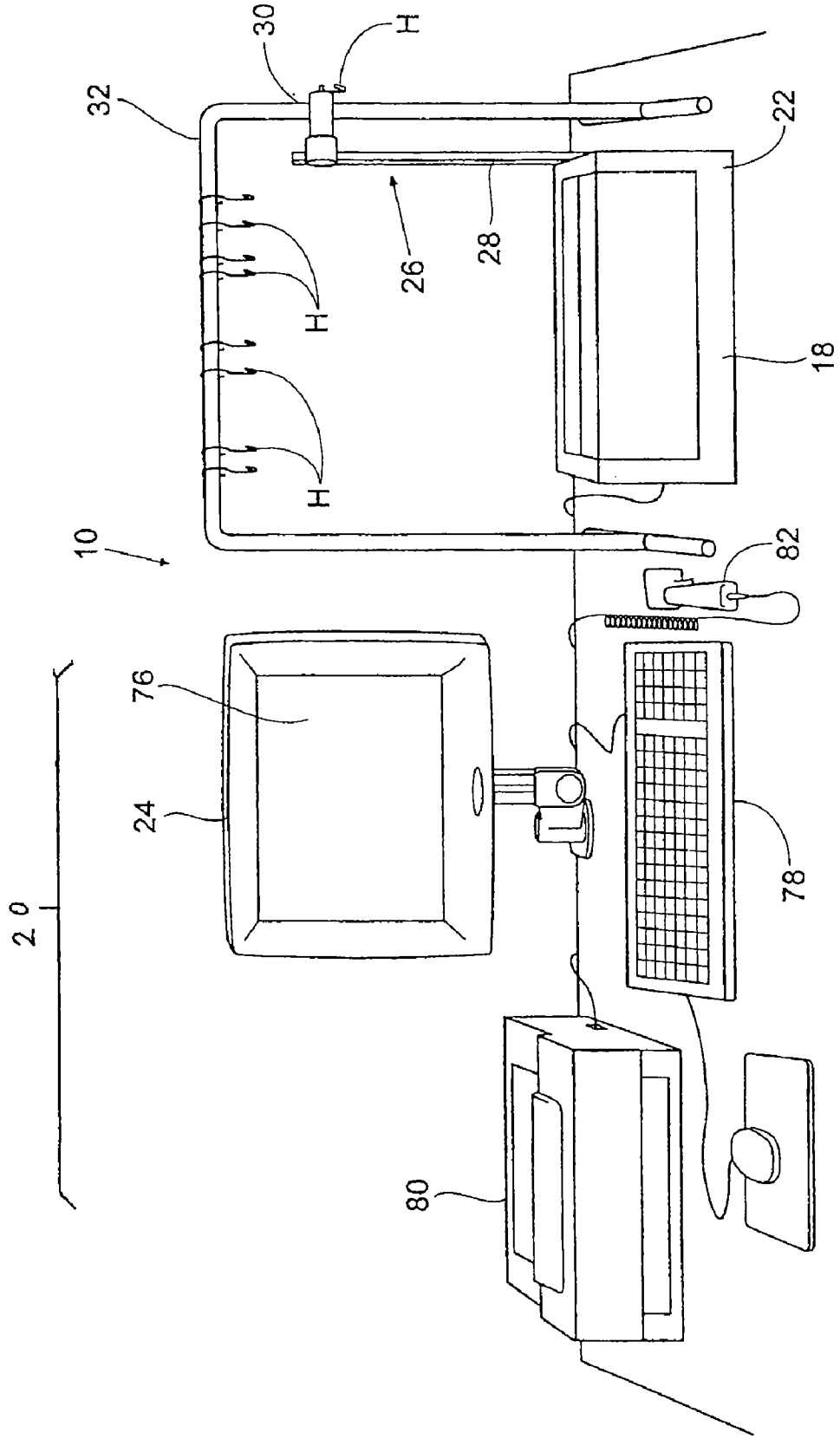

FIG. 1

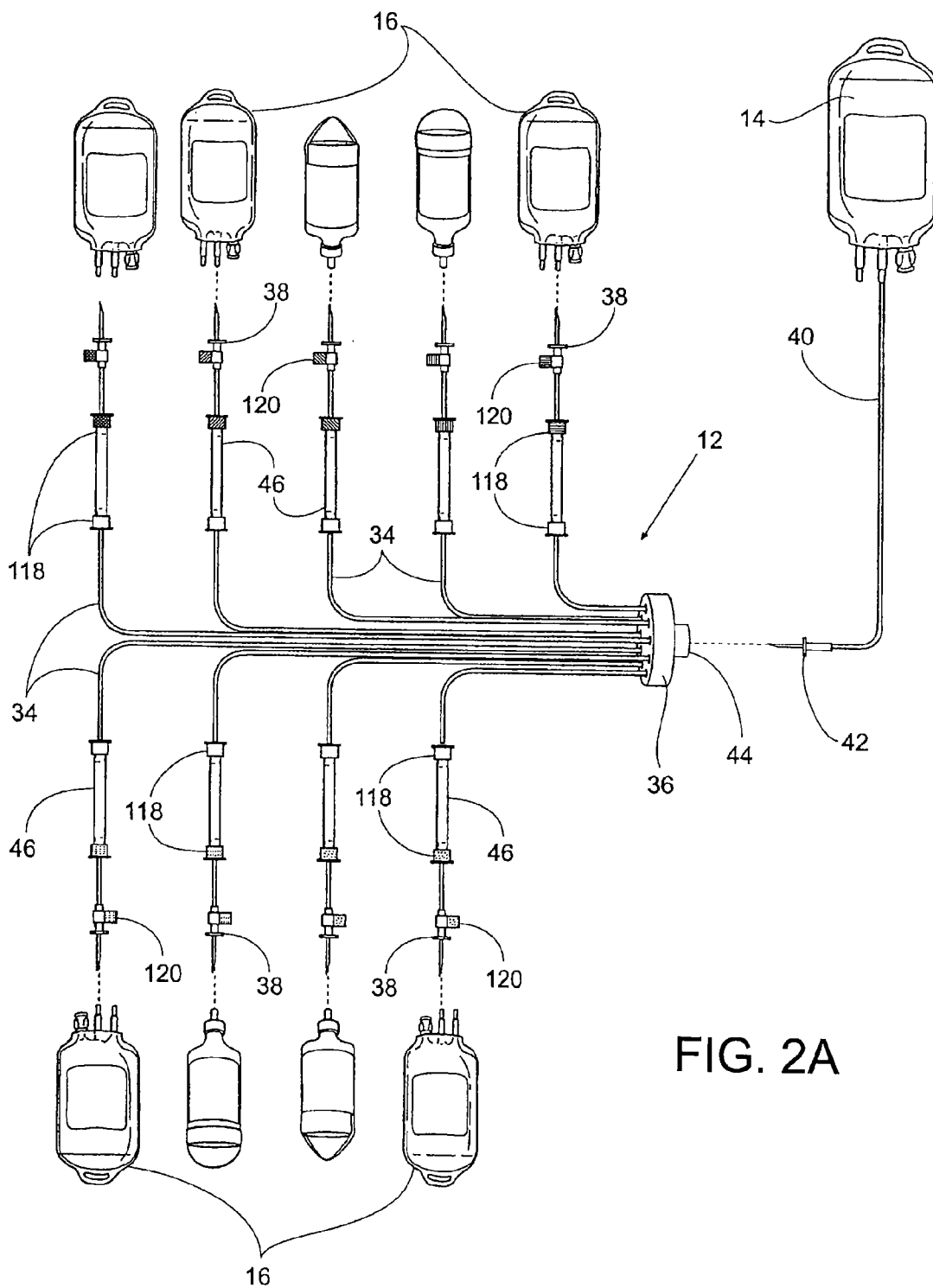

FIG. 2A

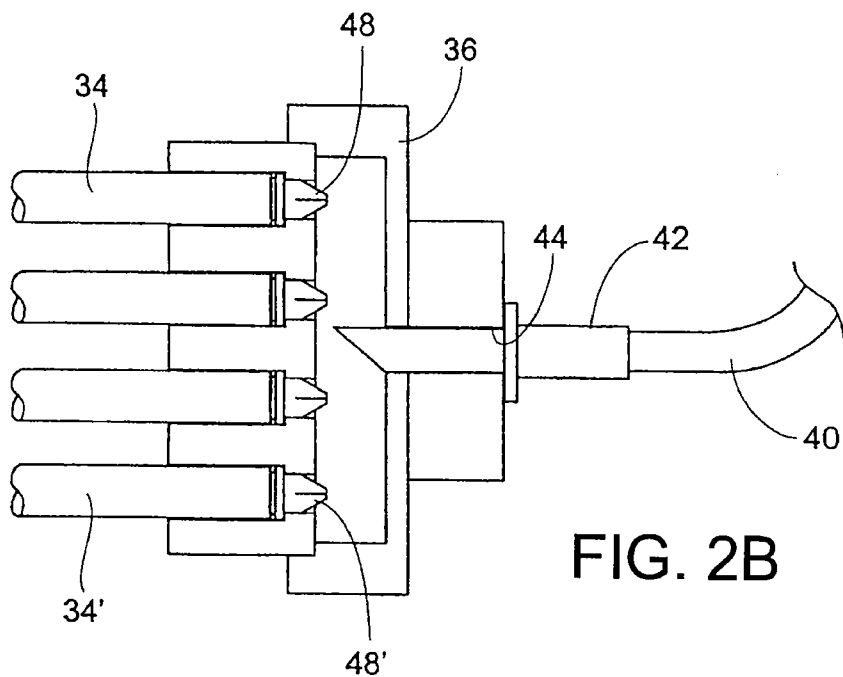

FIG. 2B

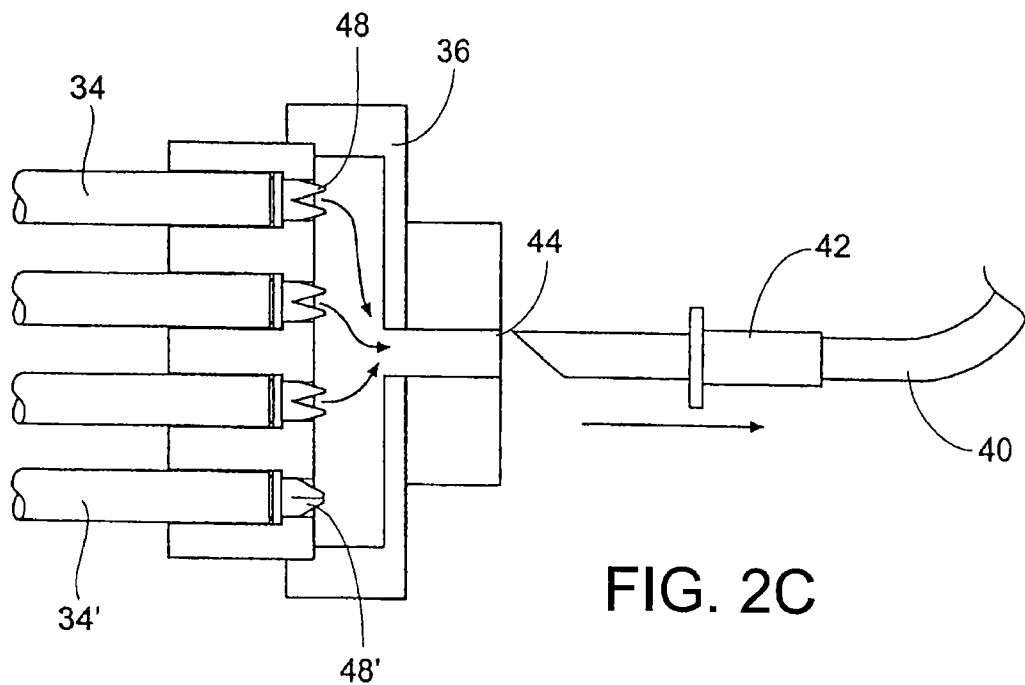

FIG. 2C

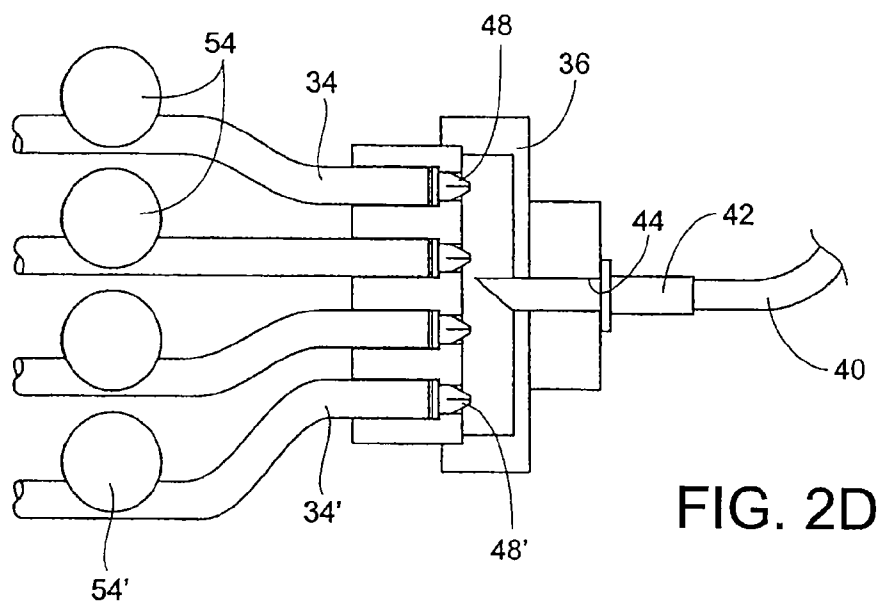

FIG. 2D

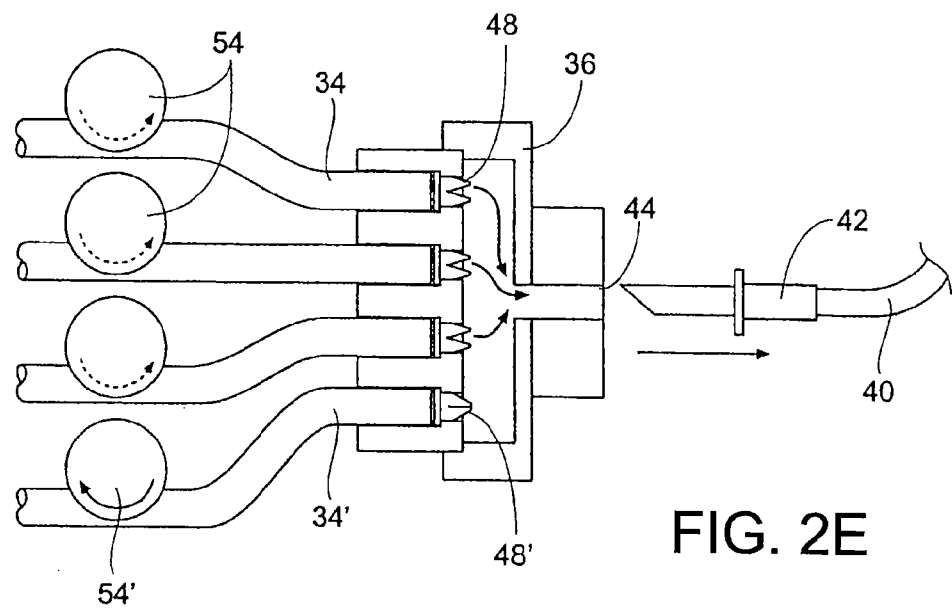

FIG. 2E

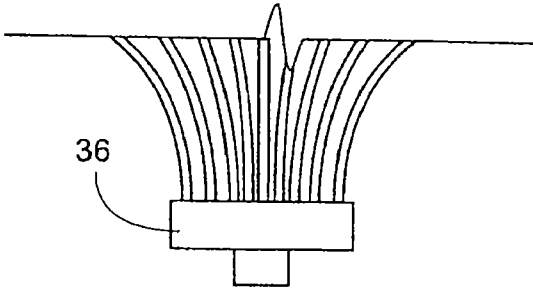
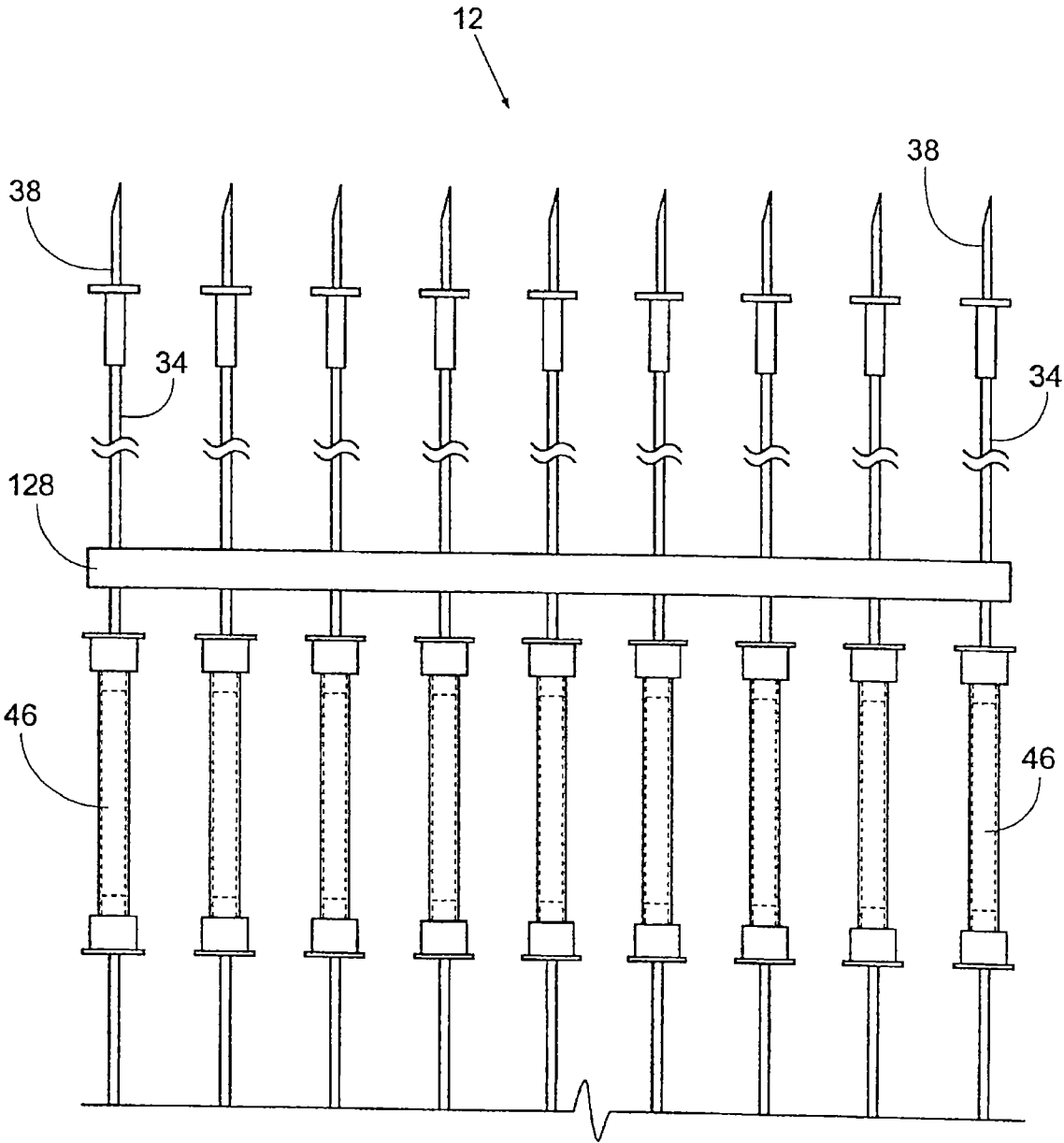

FIG. 2F

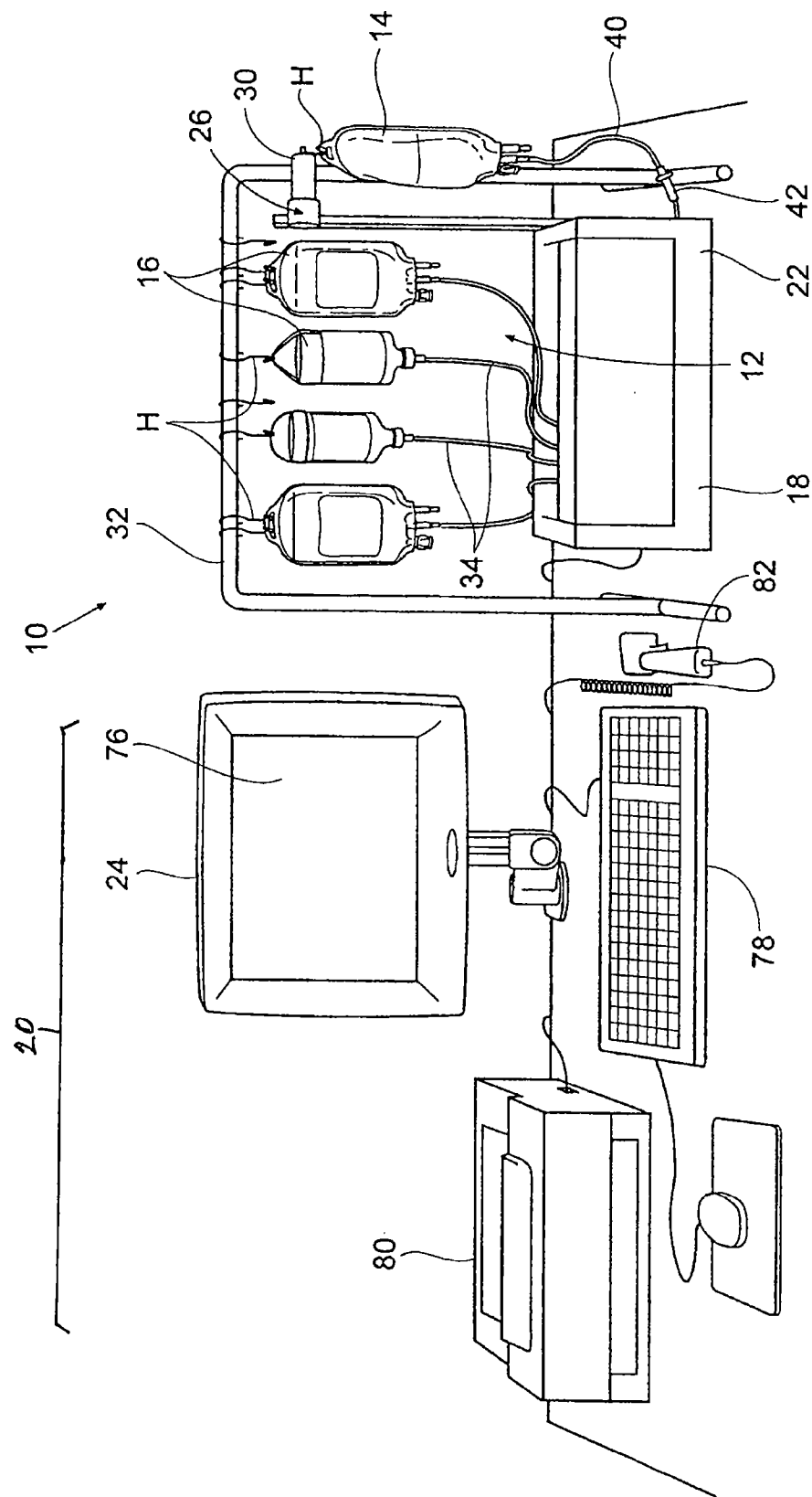

FIG. 3

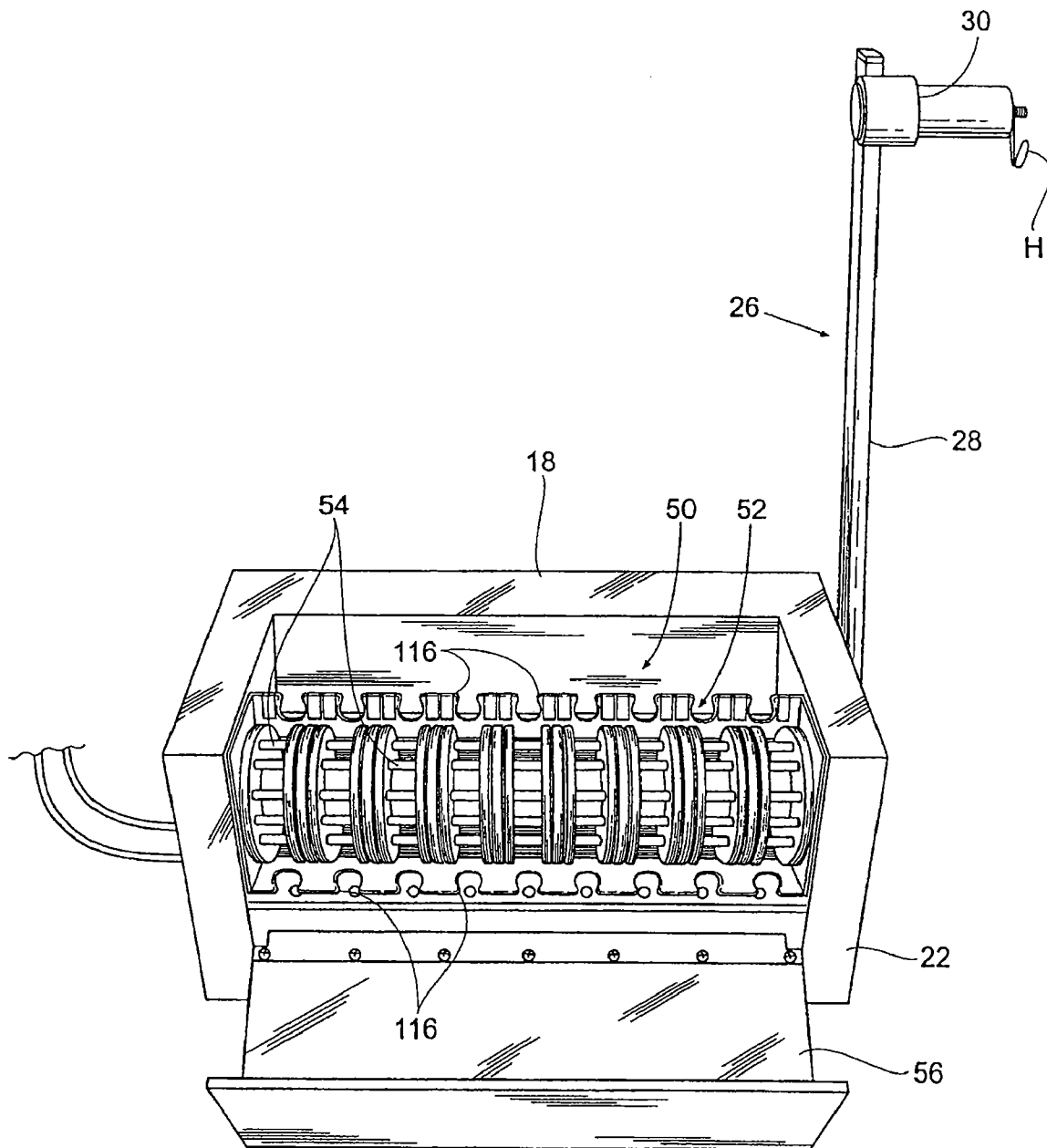

FIG. 4

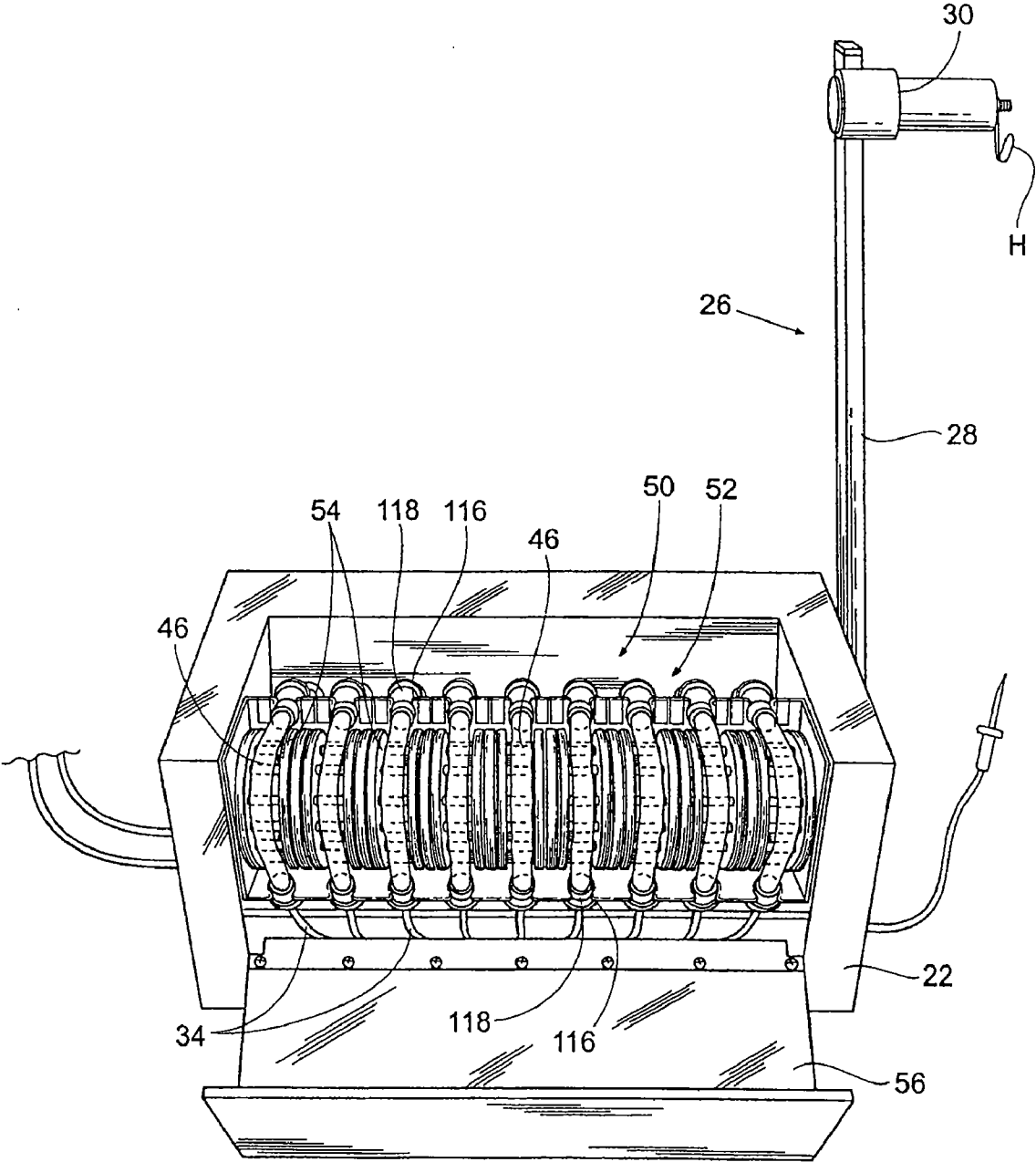

FIG. 5

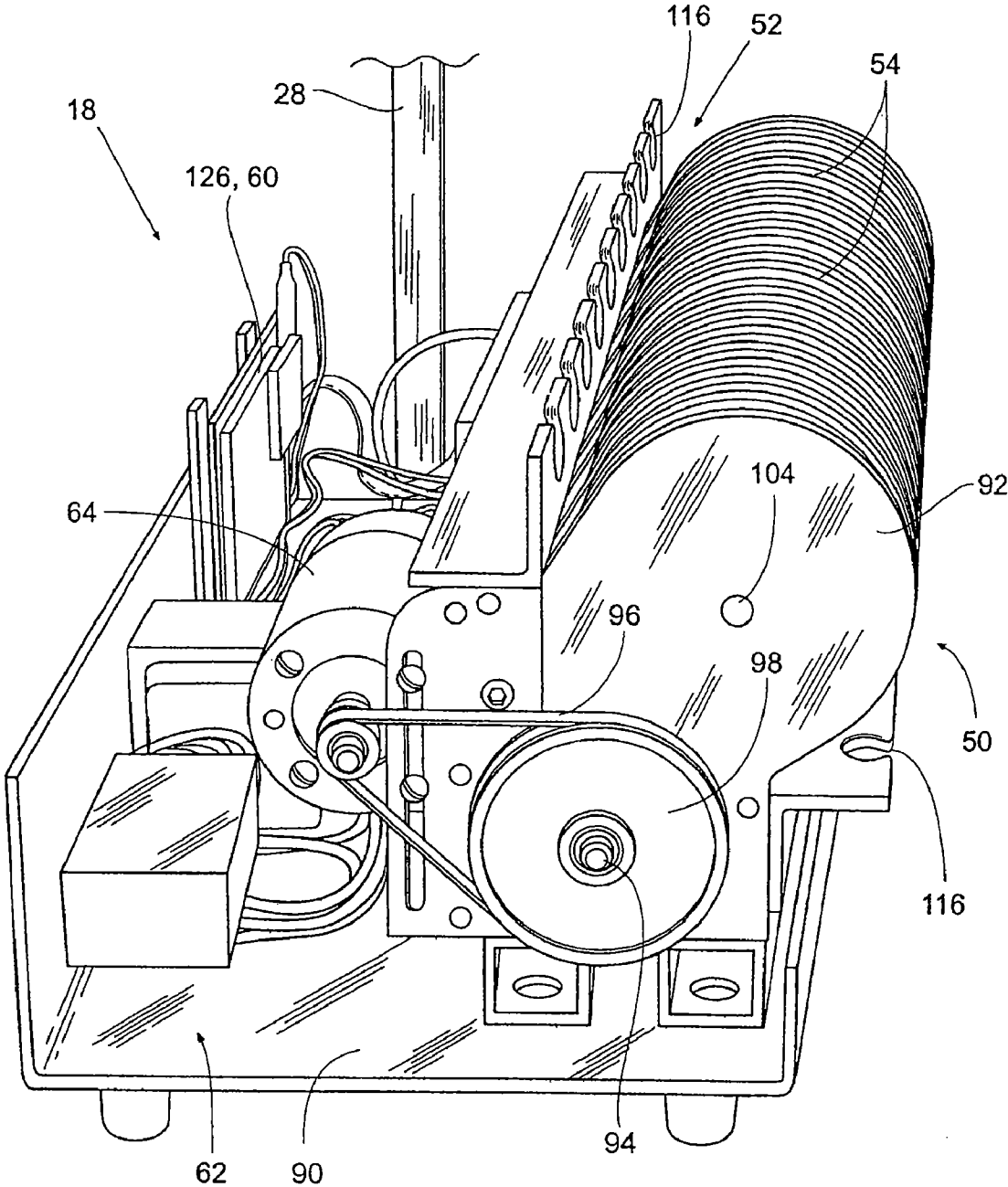

FIG. 6A

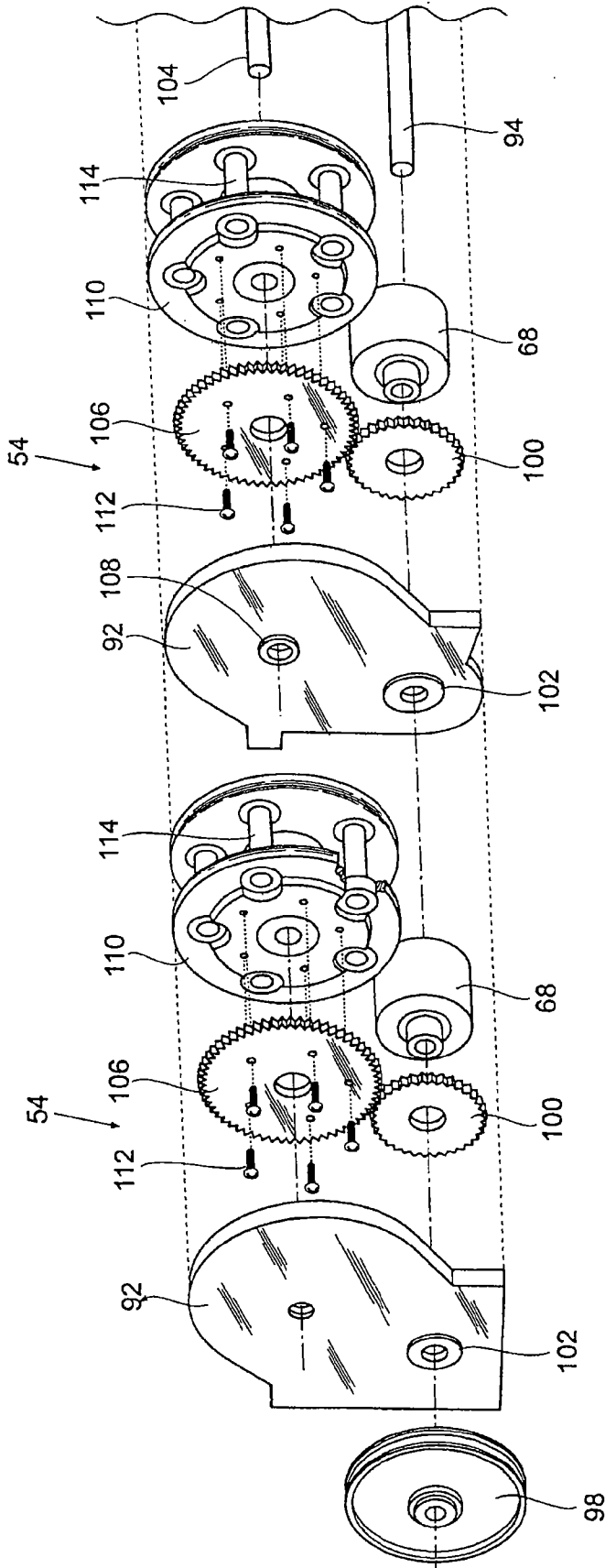

FIG. 6B

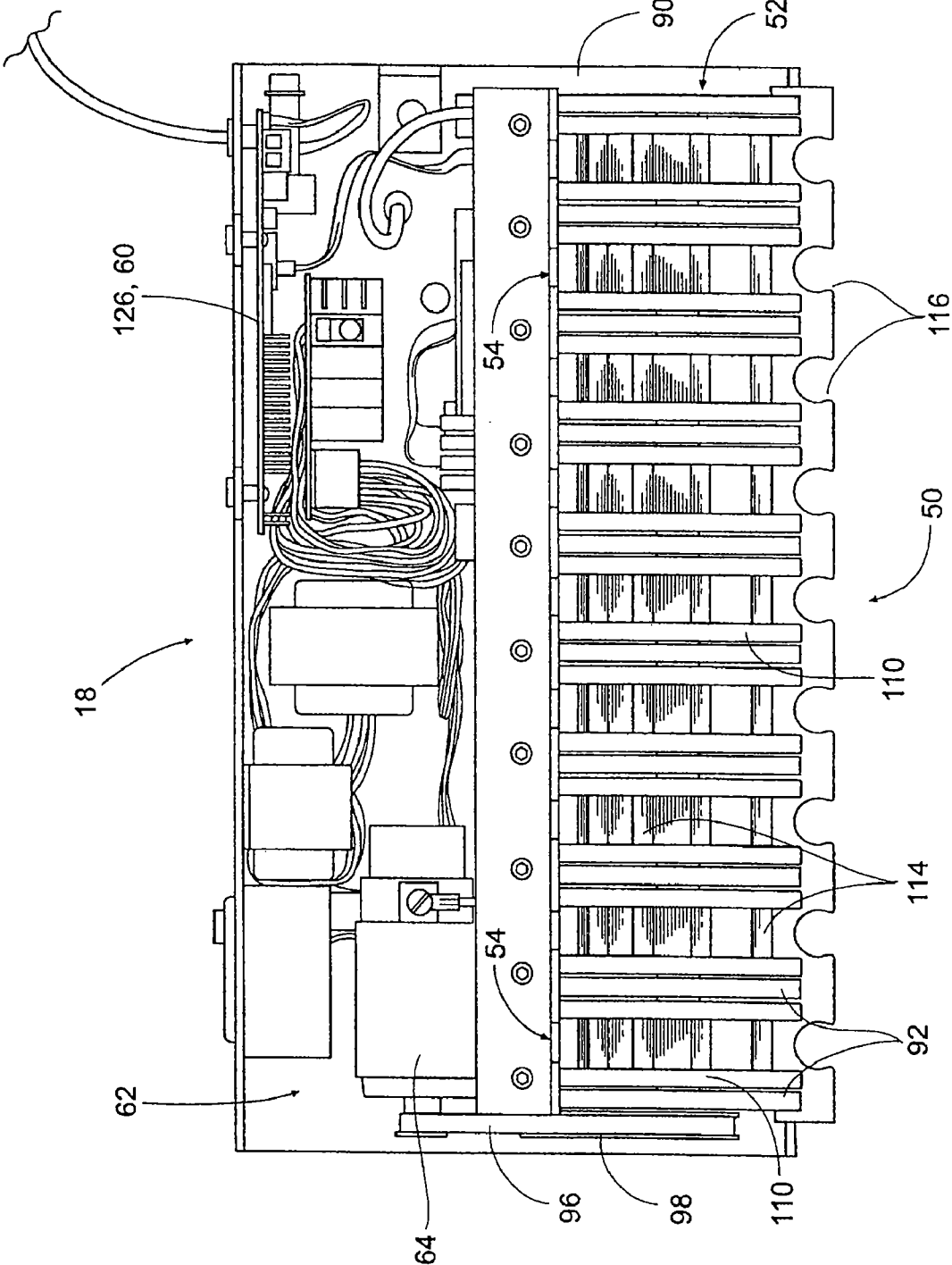

FIG. 7

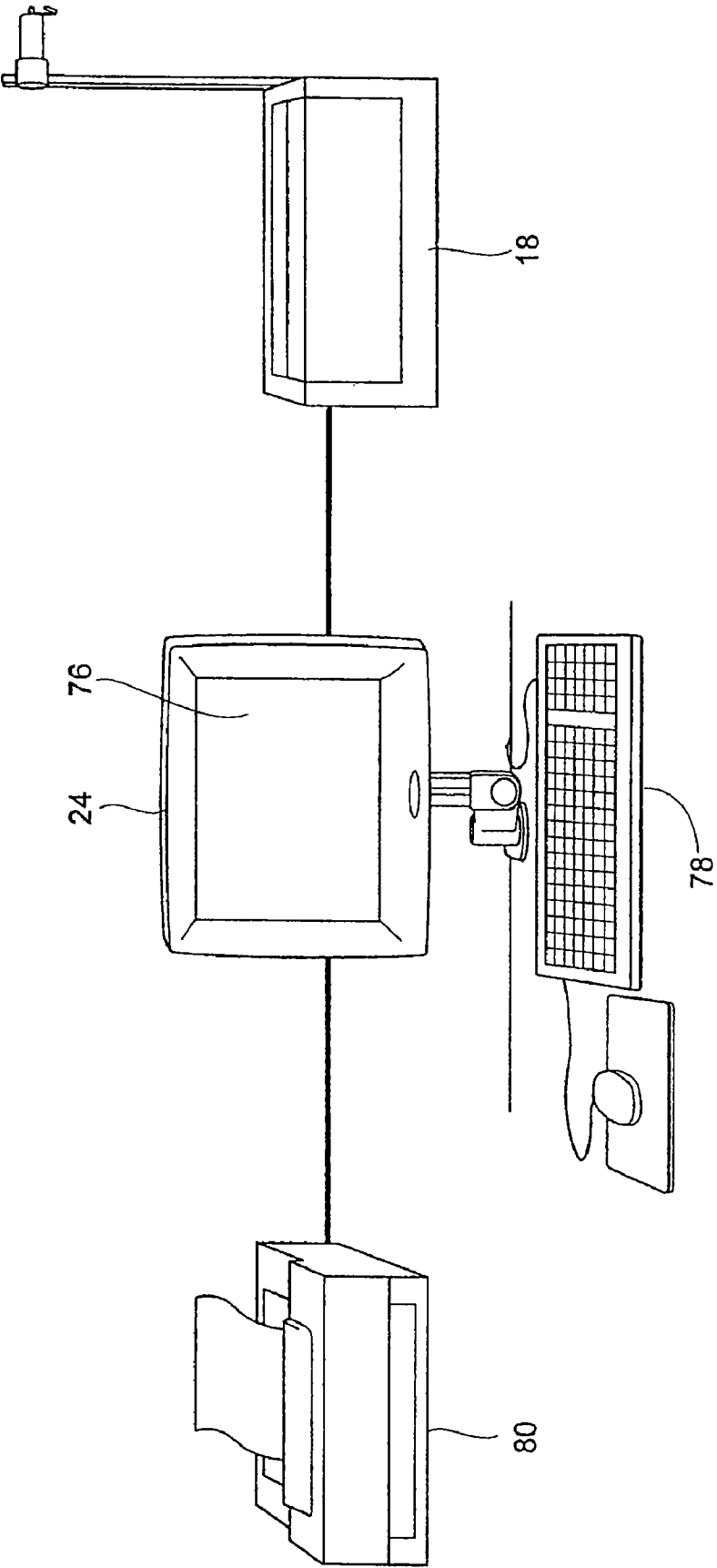

FIG. 8A

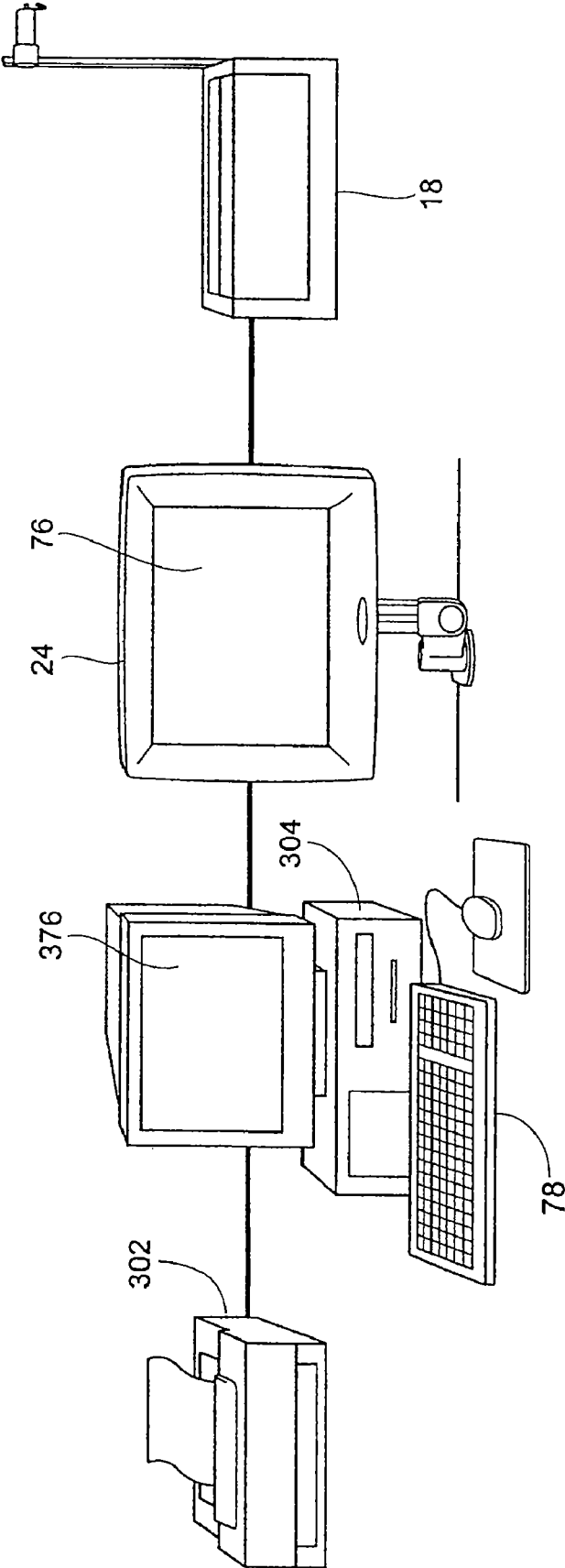

FIG. 8B

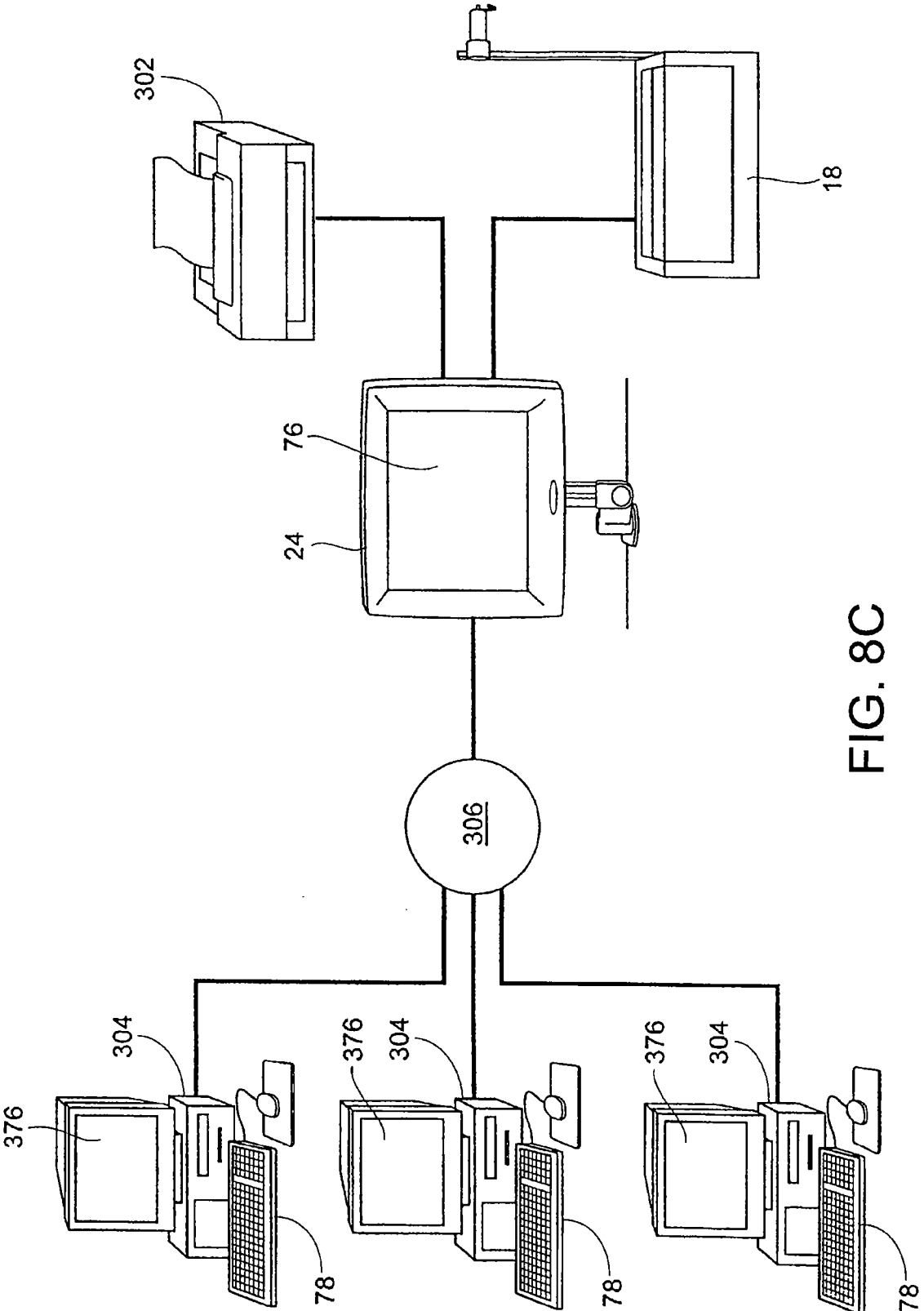

FIG. 8C

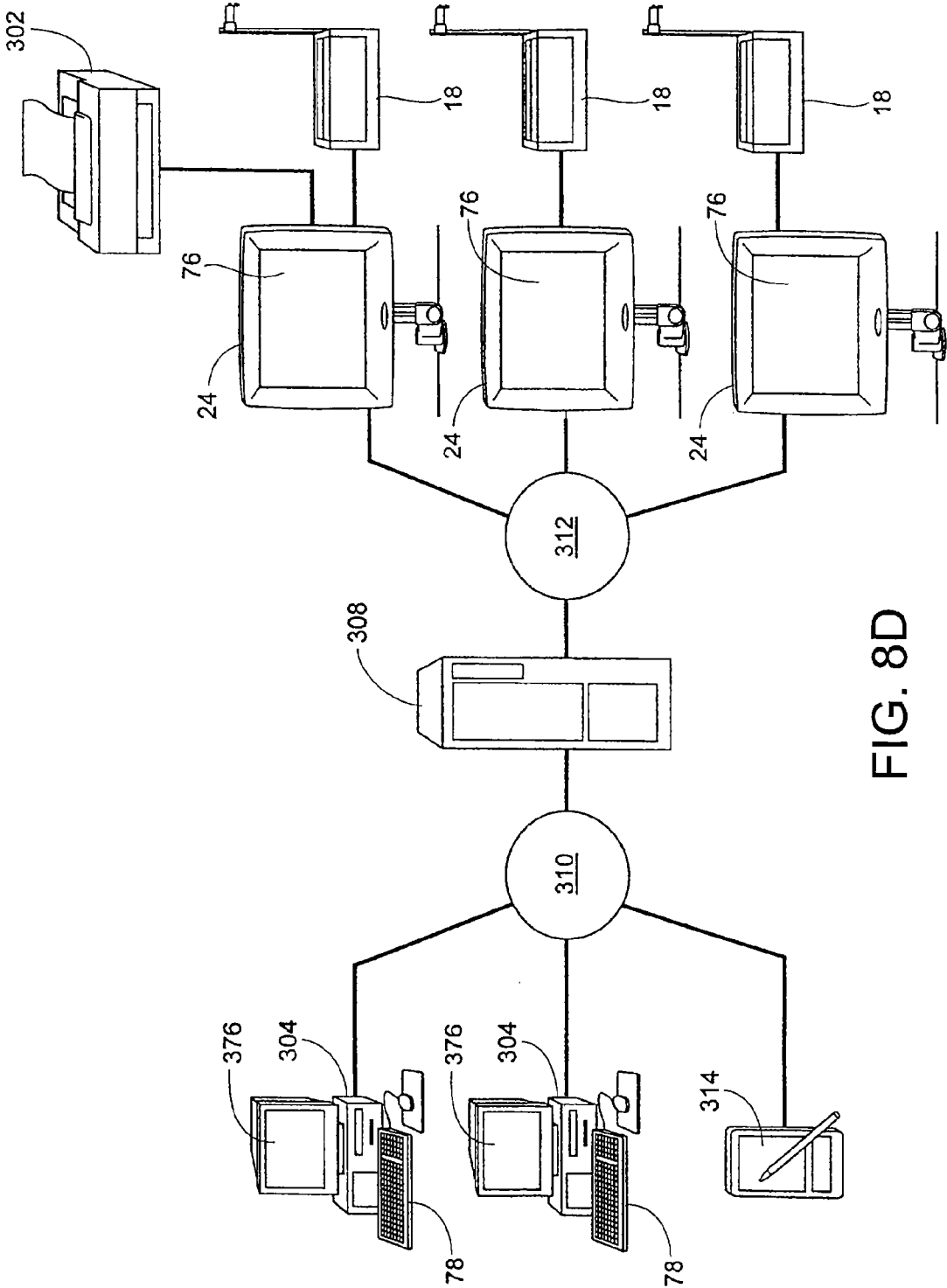

FIG. 8D

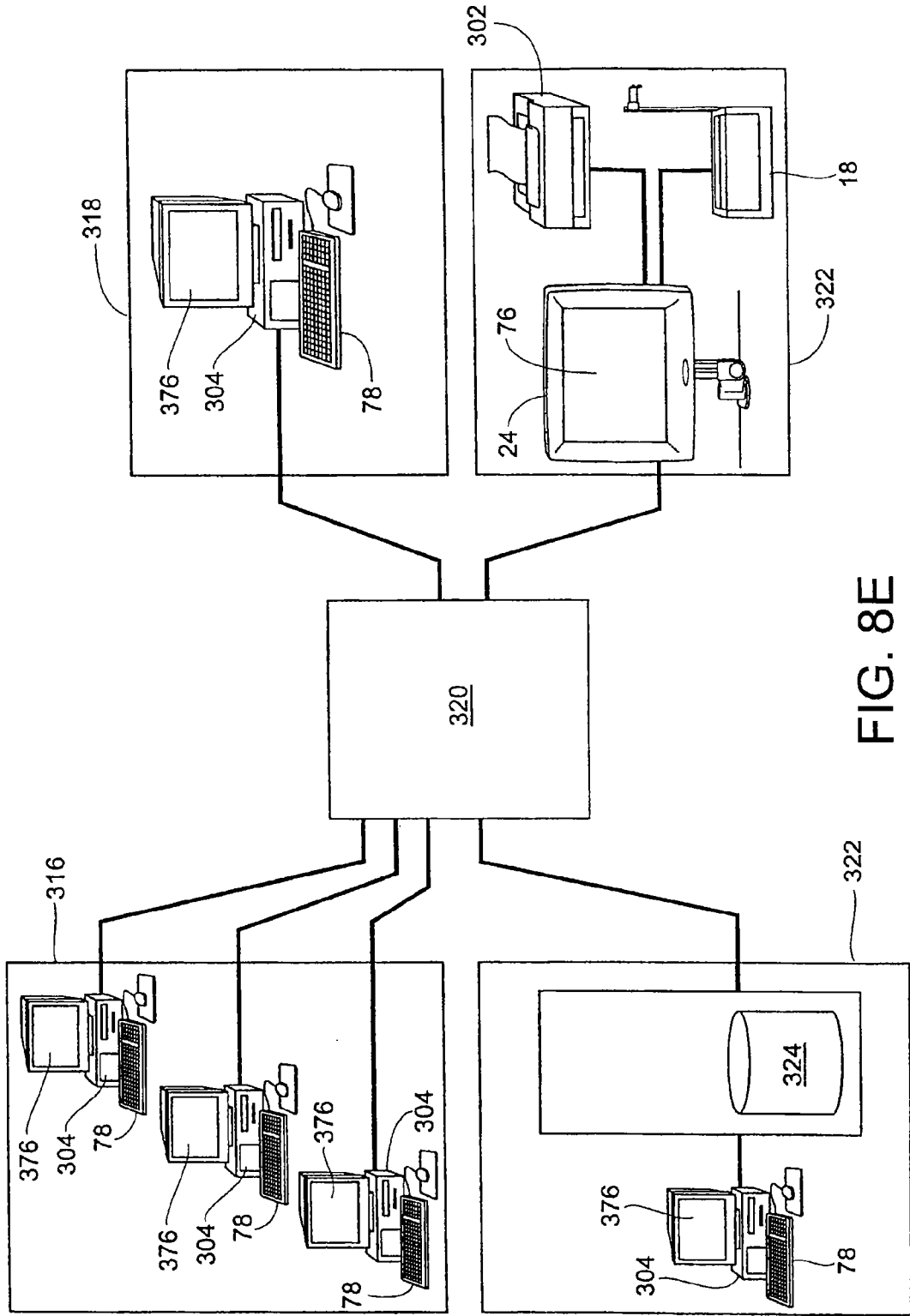

FIG. 8E

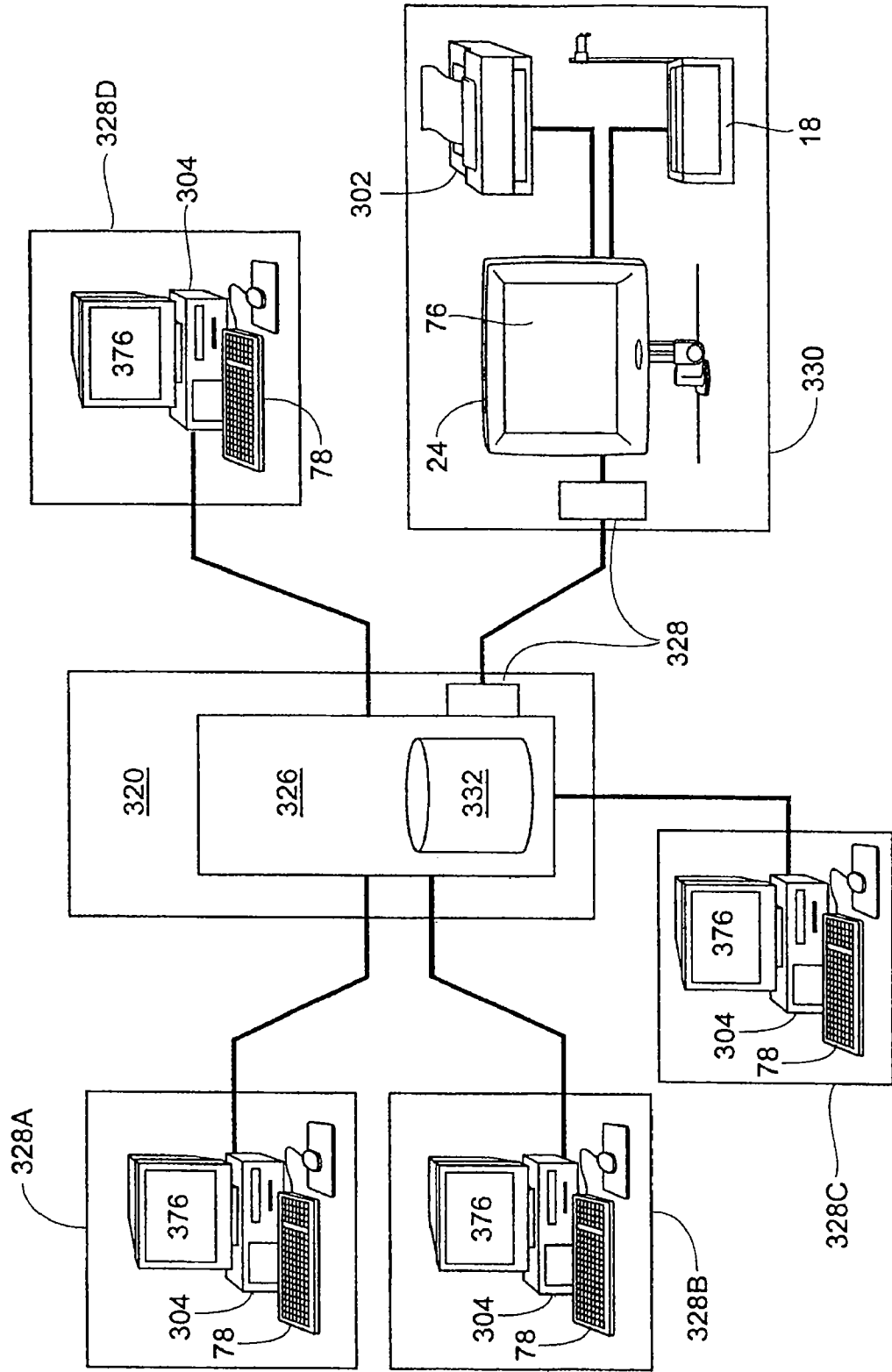

FIG. 8F

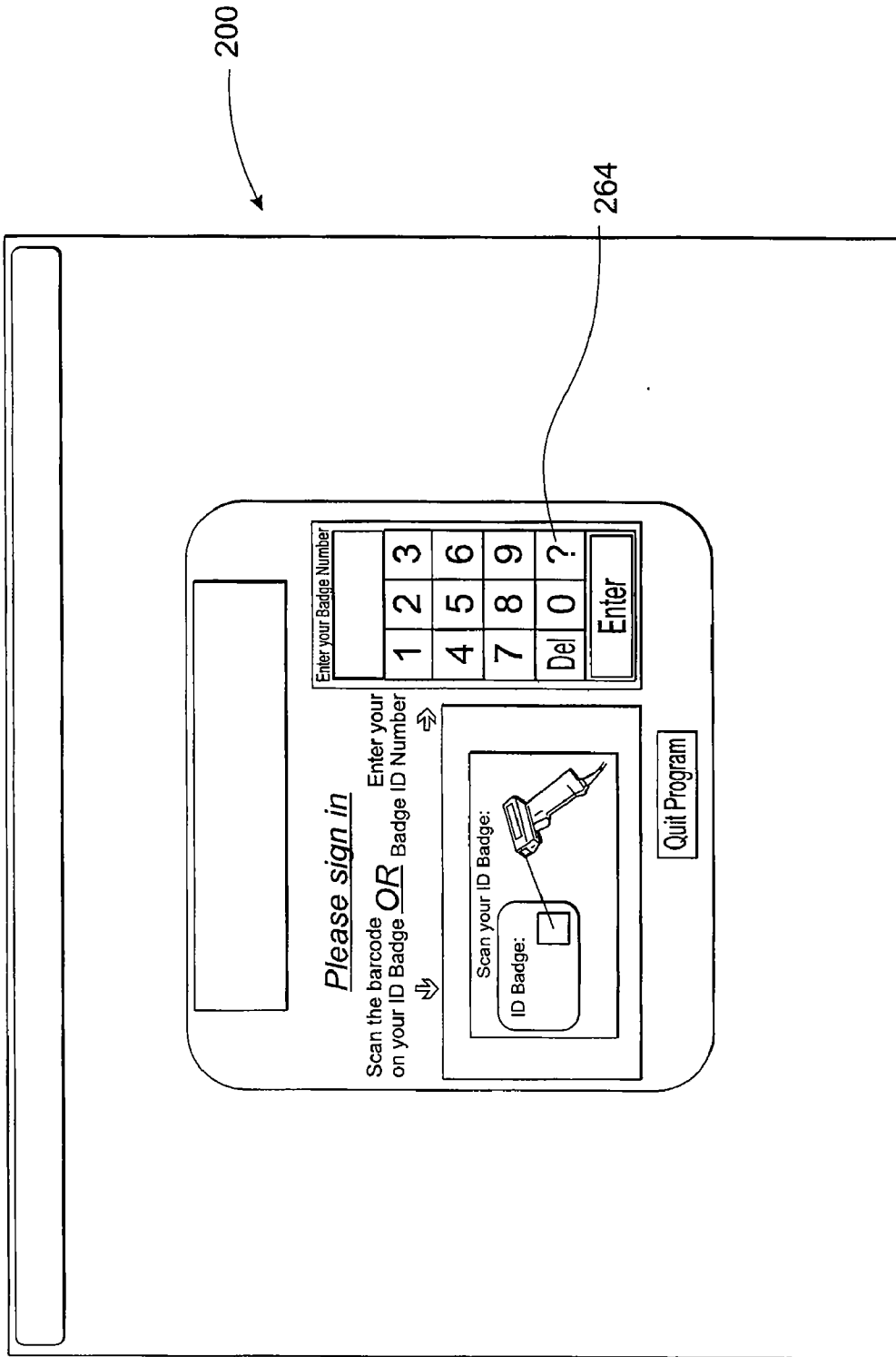

FIG. 9A

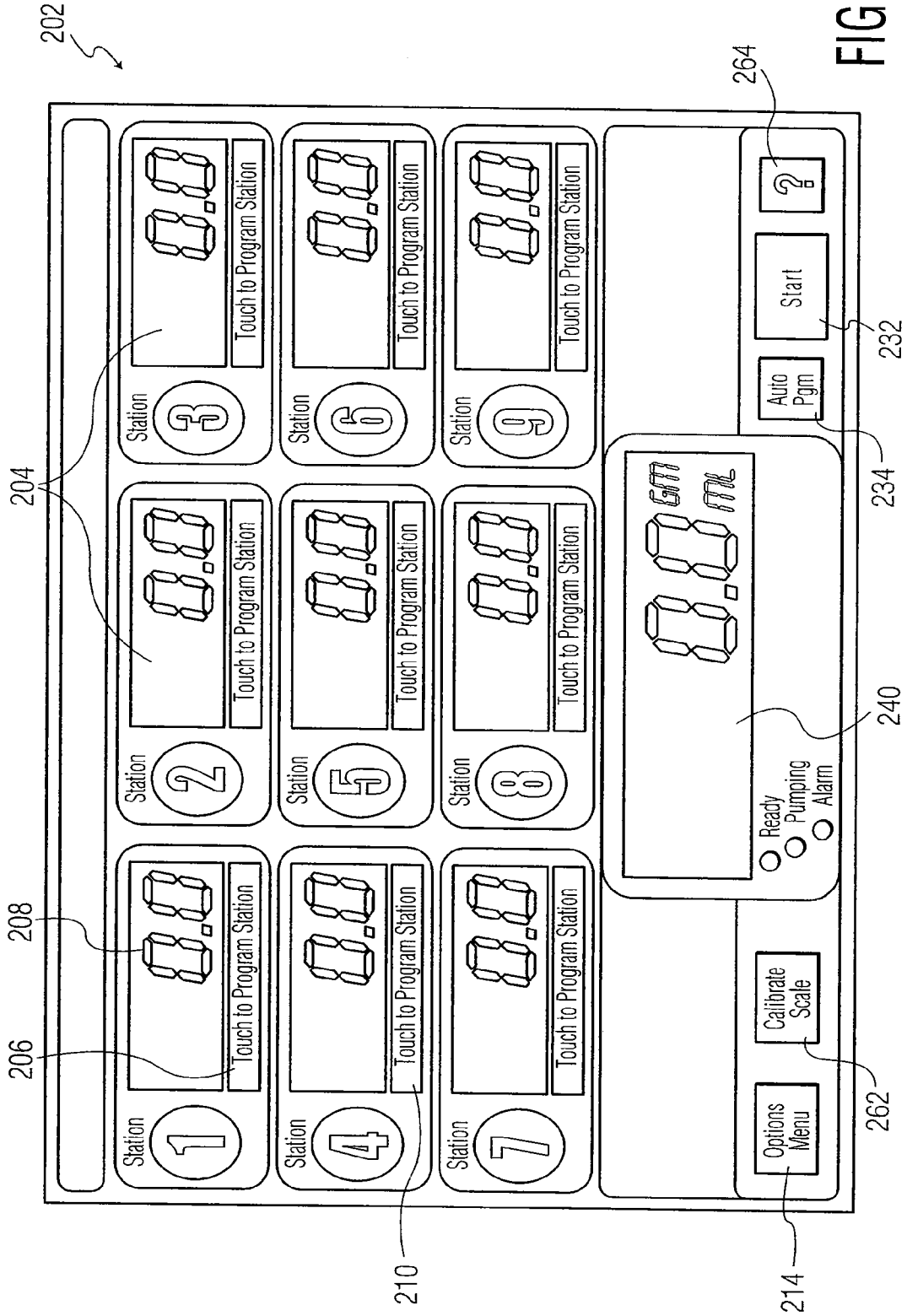

FIG. 9B

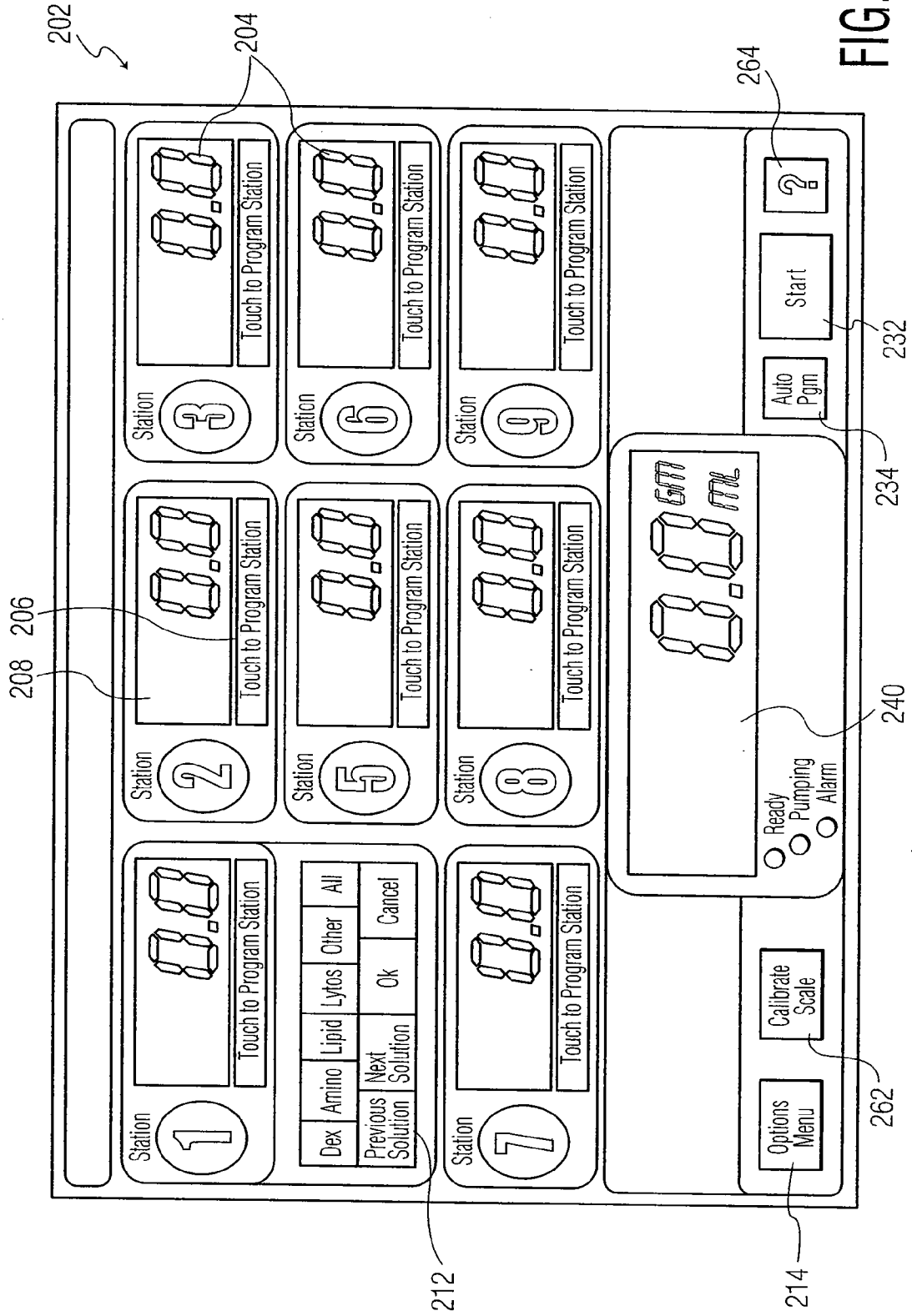

FIG. 9C

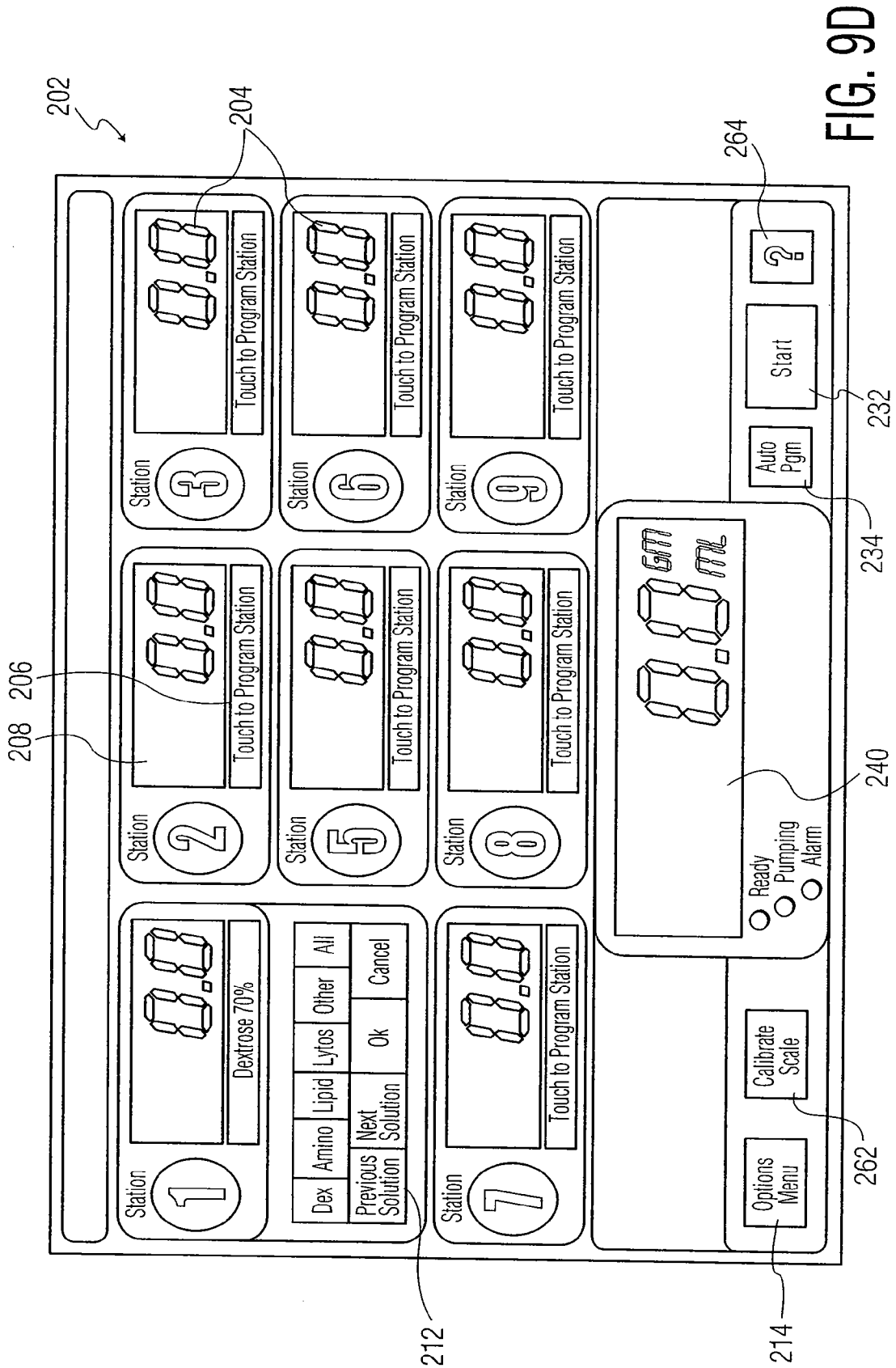

FIG. 9D

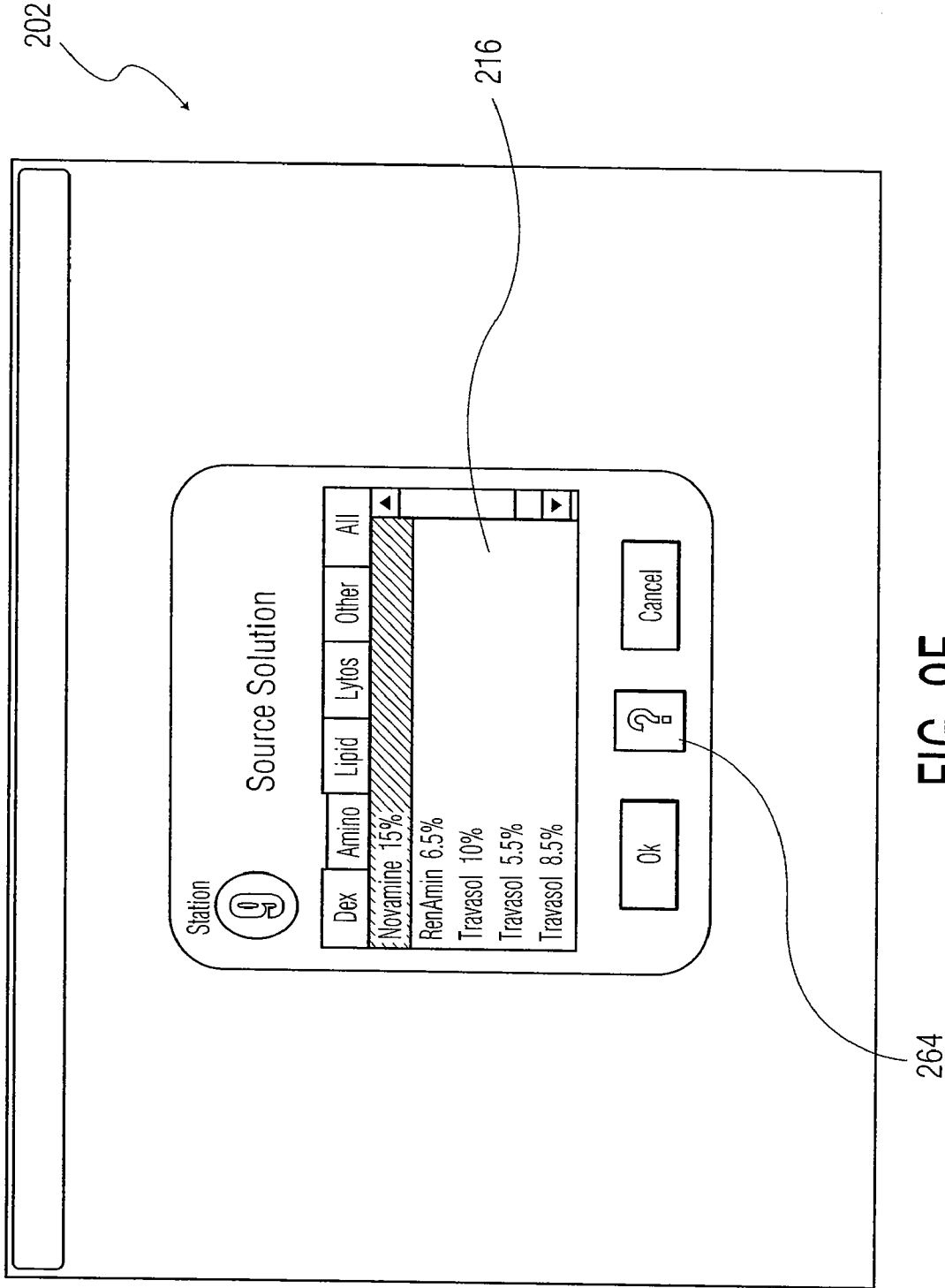

FIG. 9E

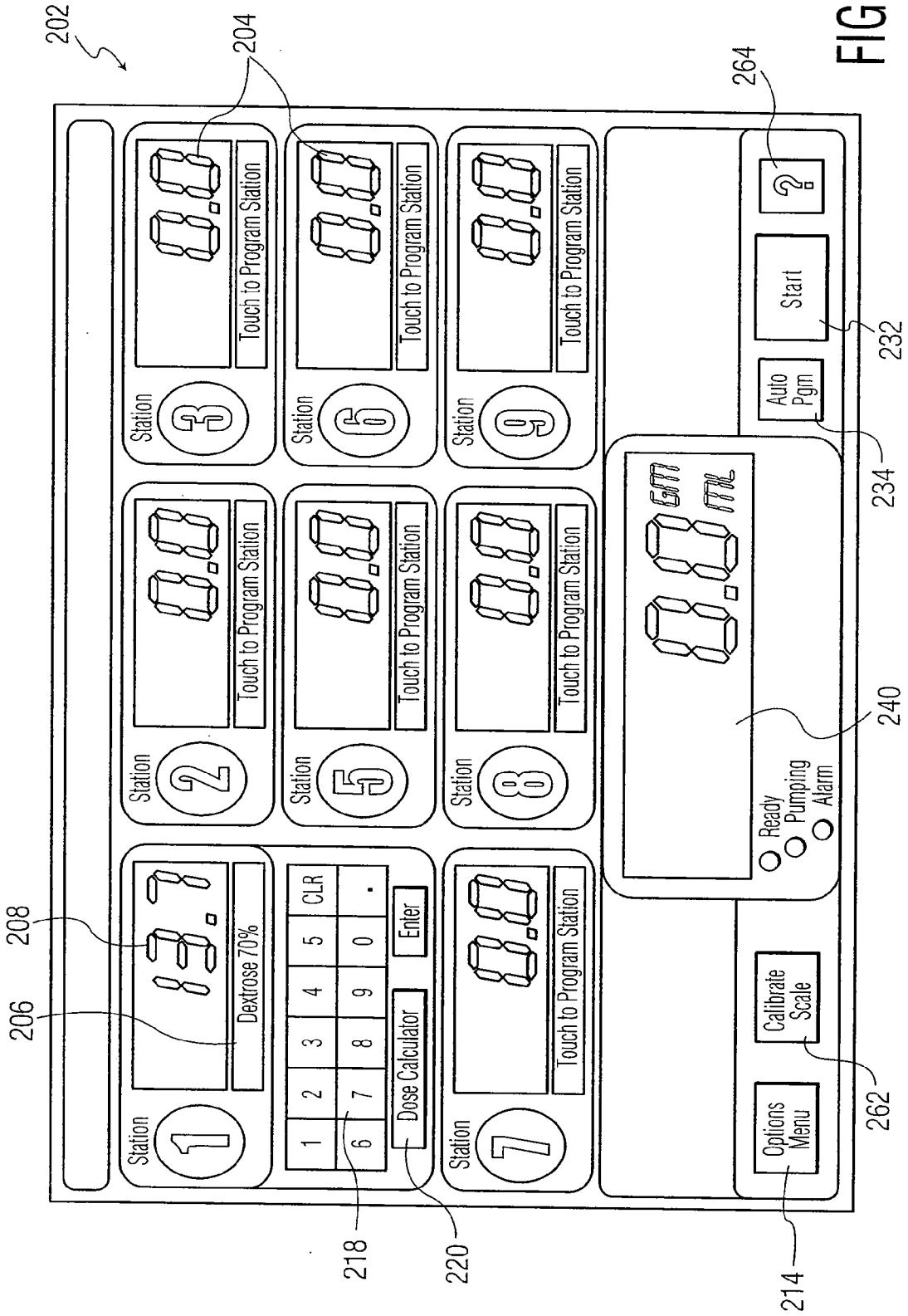

FIG. 9F

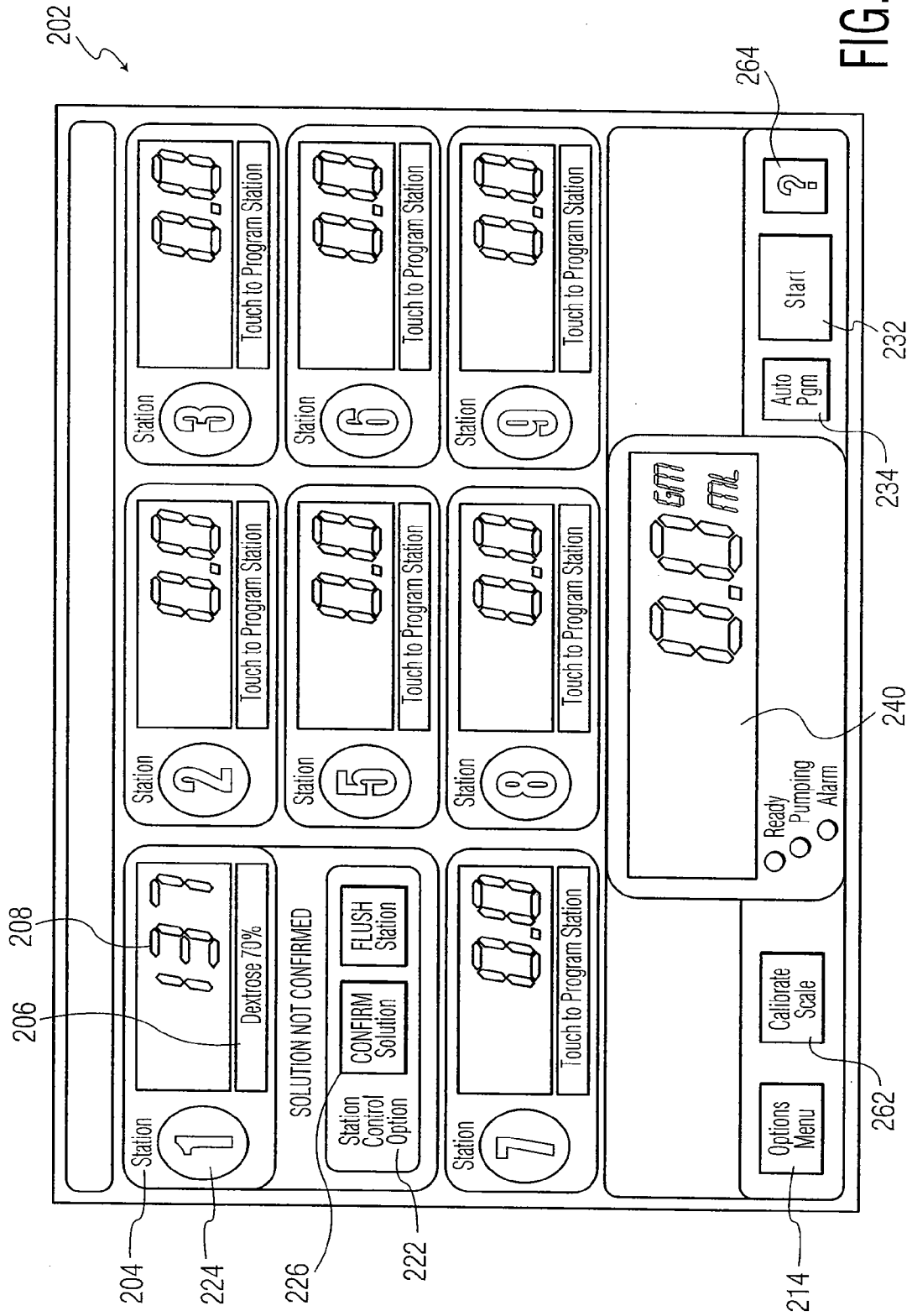

FIG. 9G

902

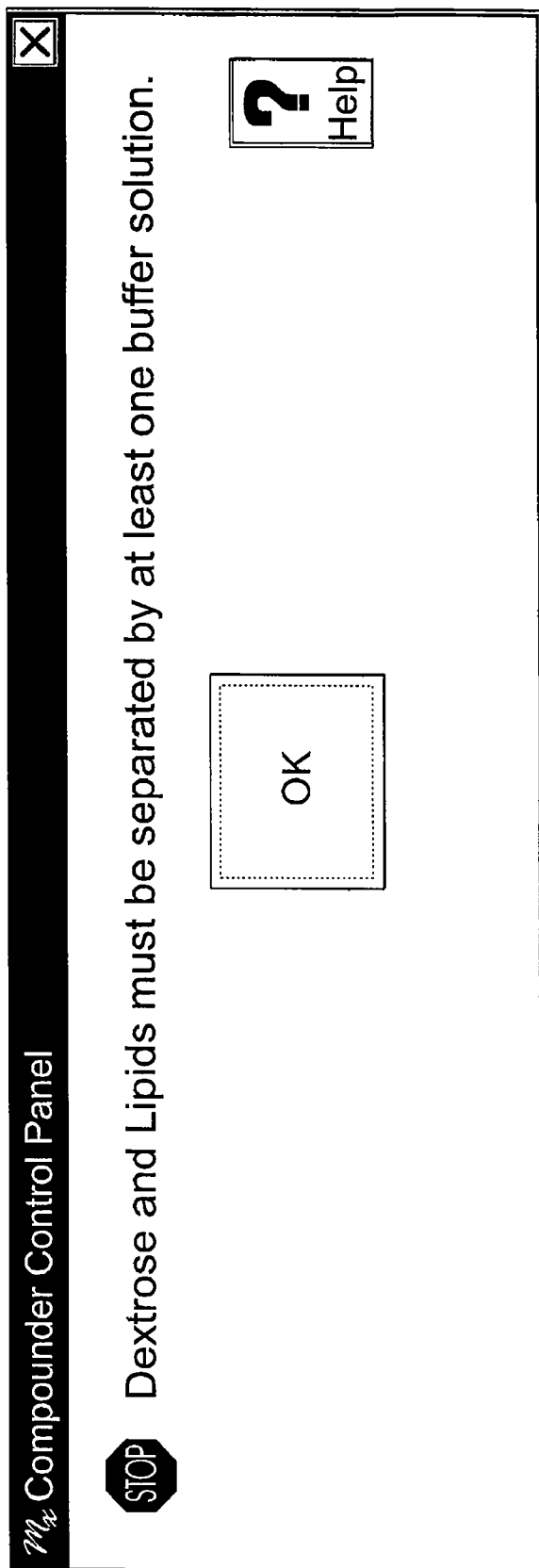

FIG. 9G(1)

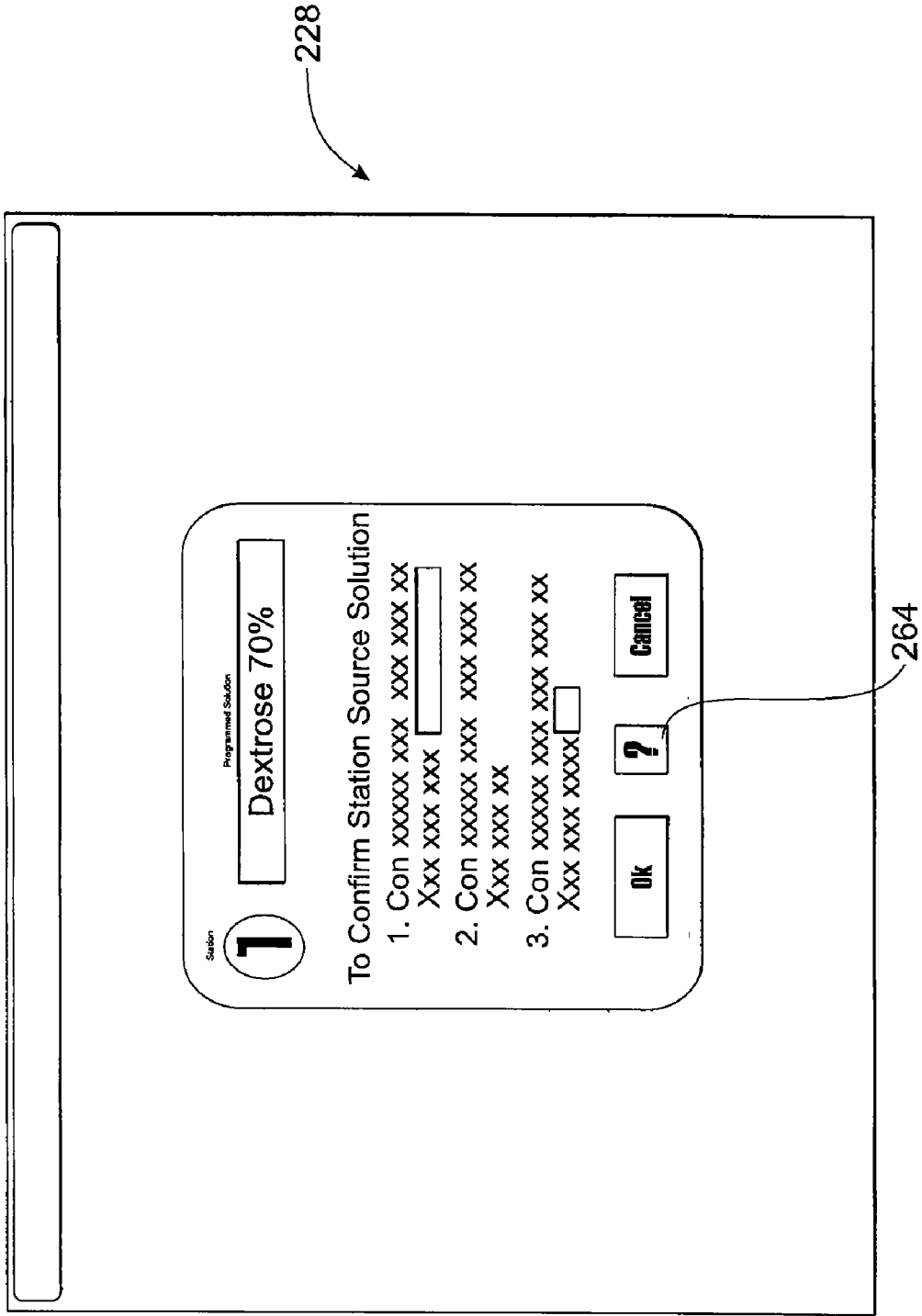

FIG. 9H

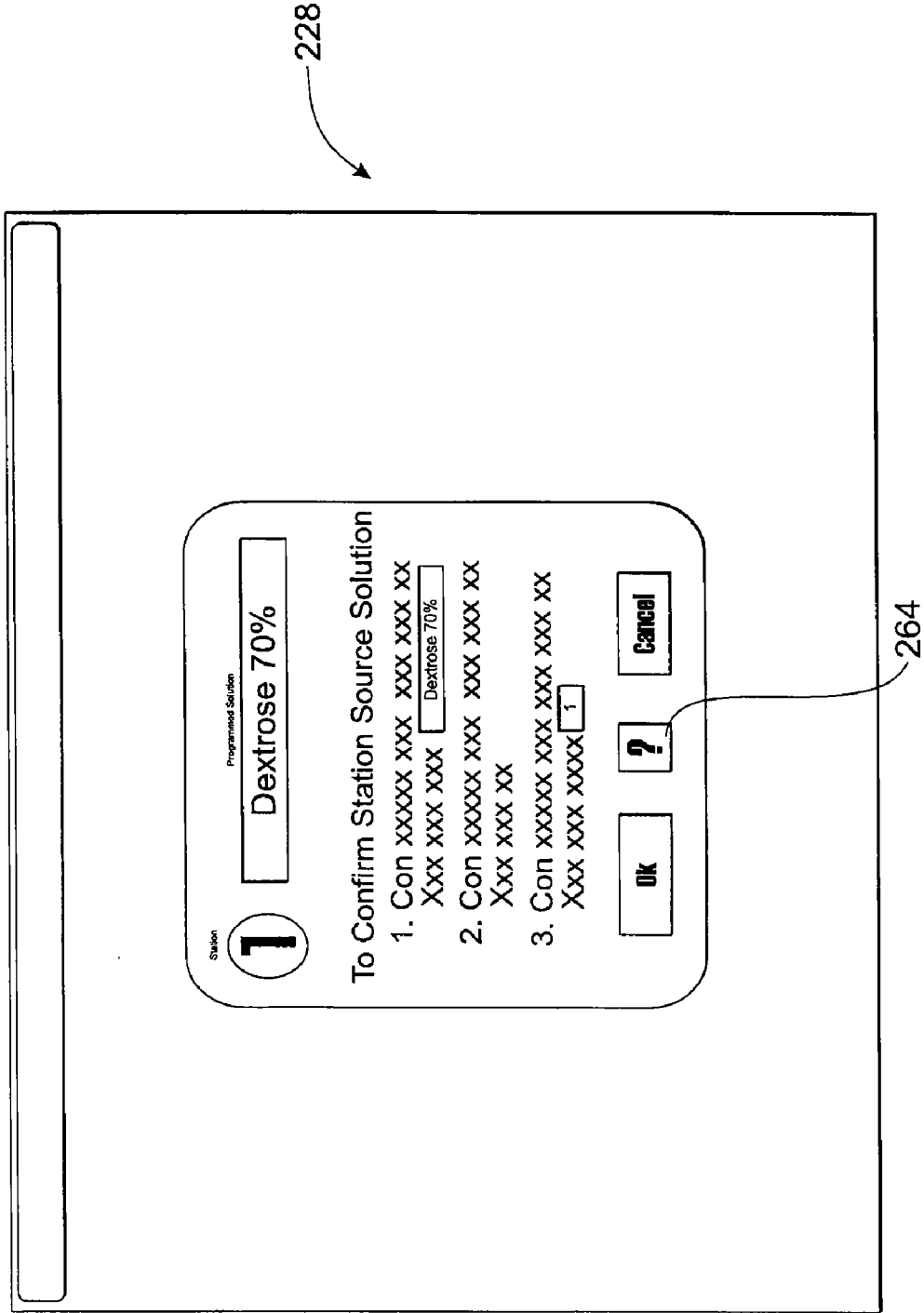

FIG. 9I(1)

900

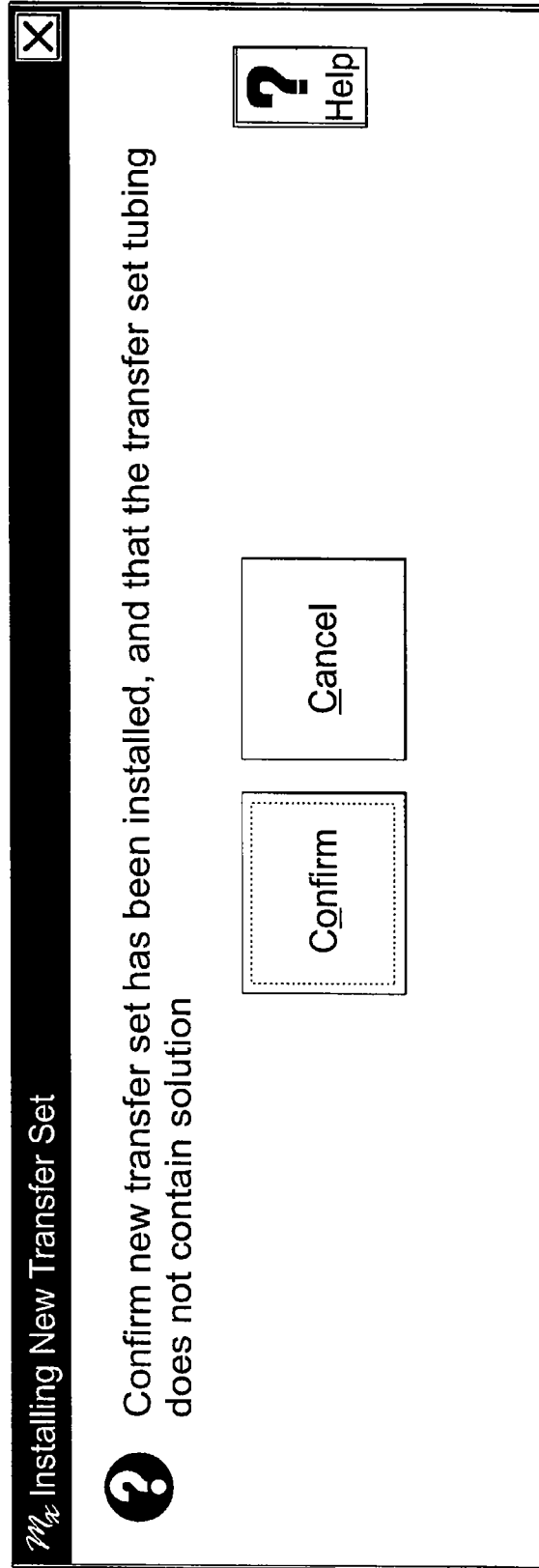

FIG. 9I(2)

904

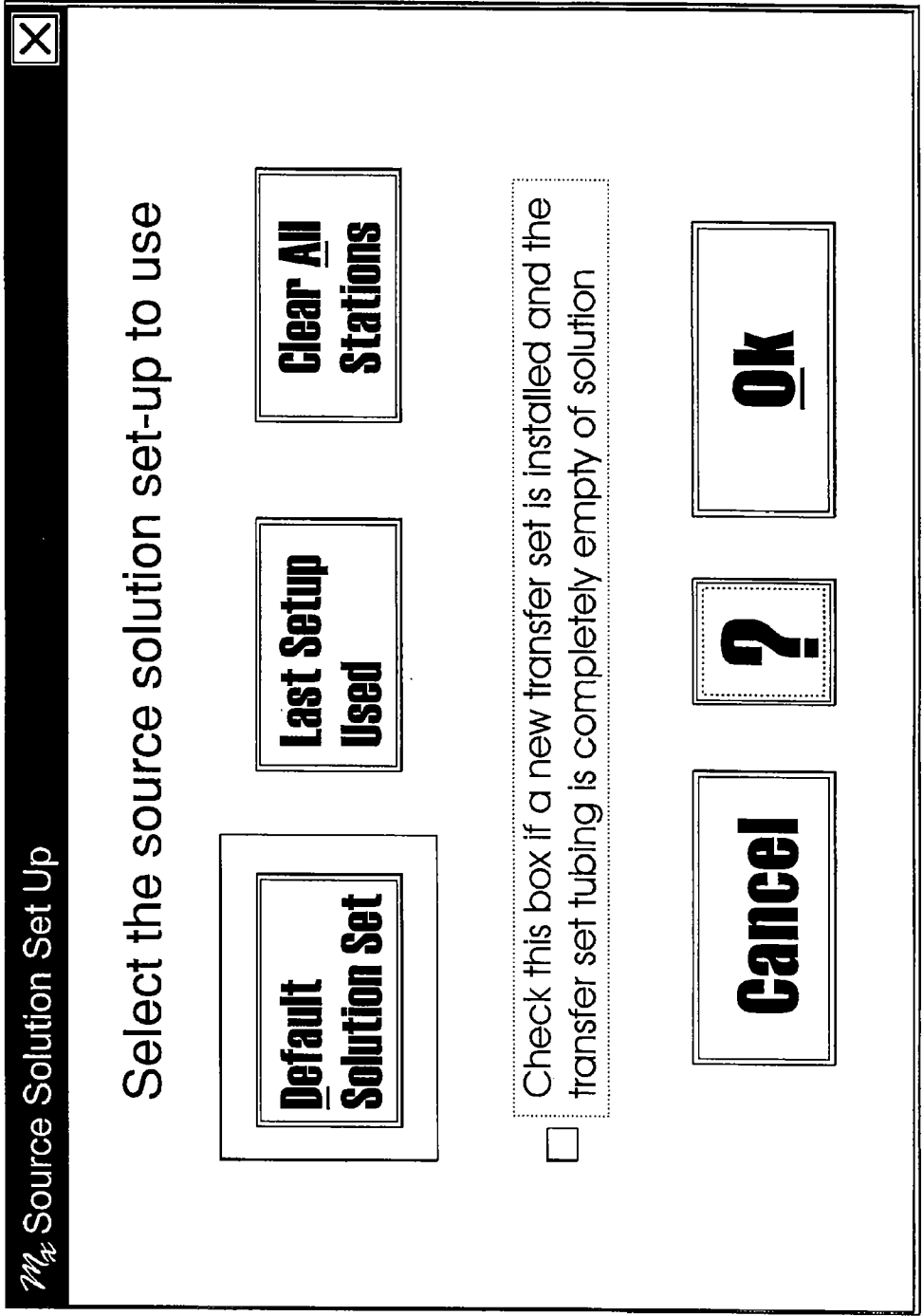

FIG. 9I(3)

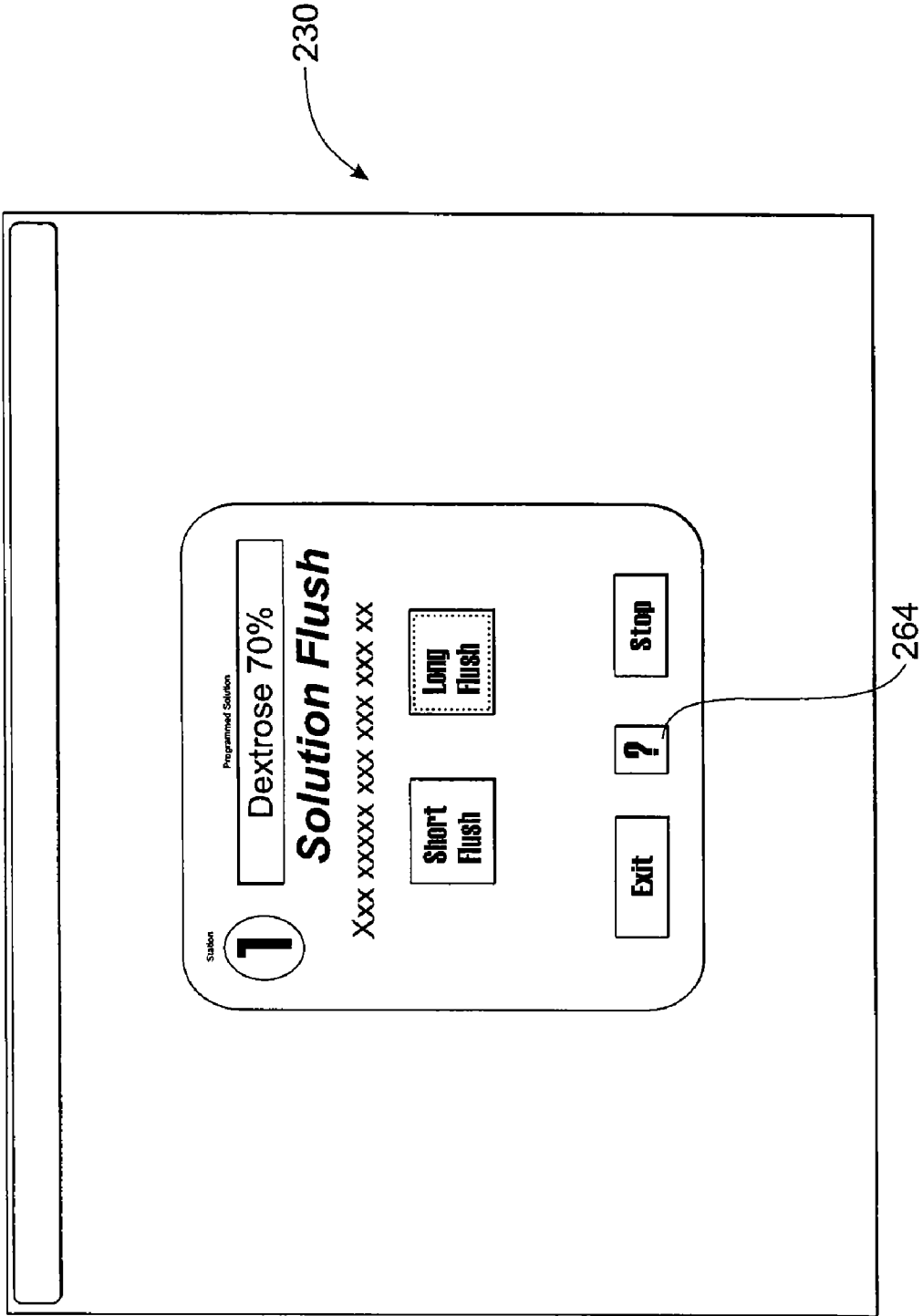

FIG. 9J

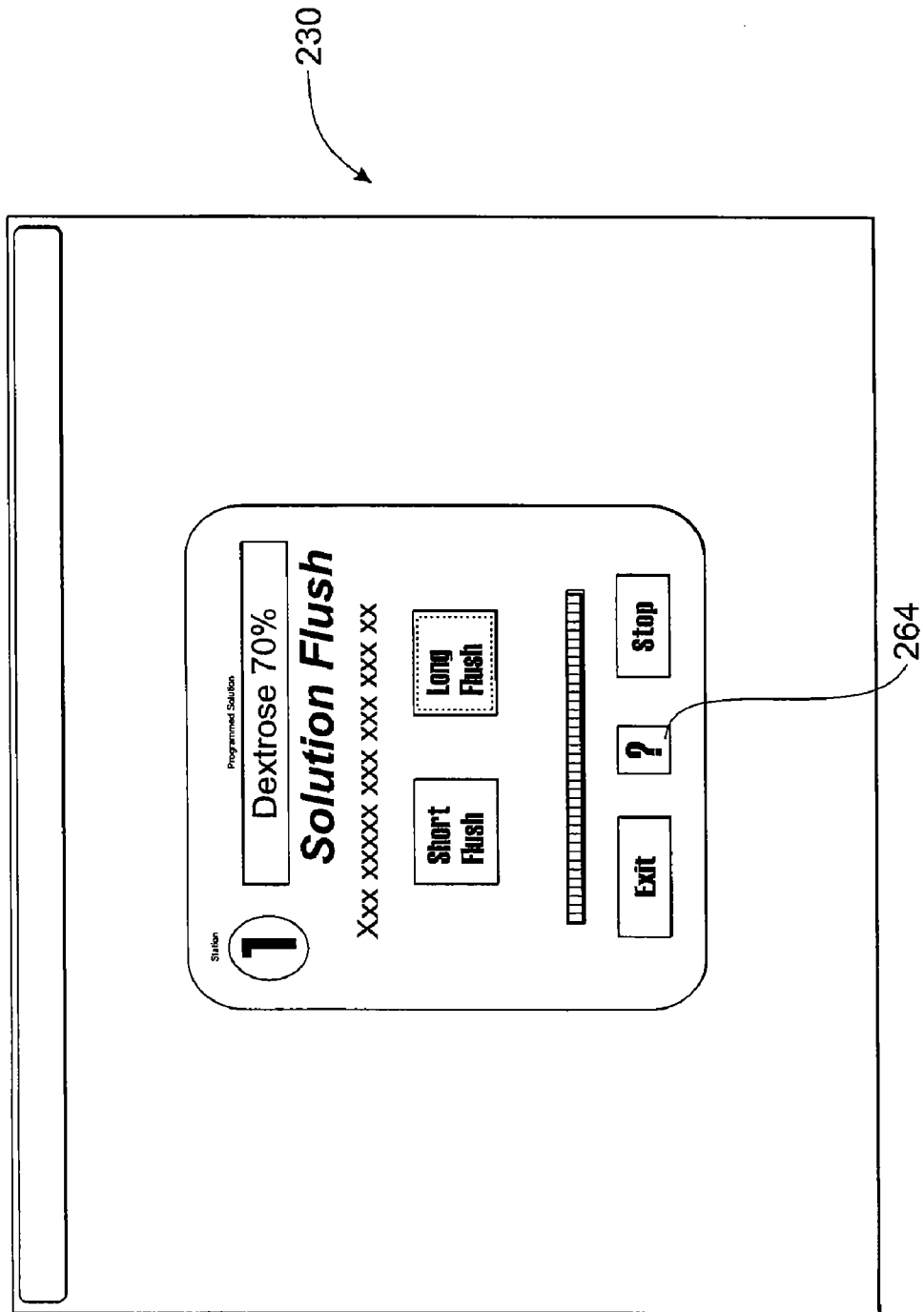

FIG. 9K

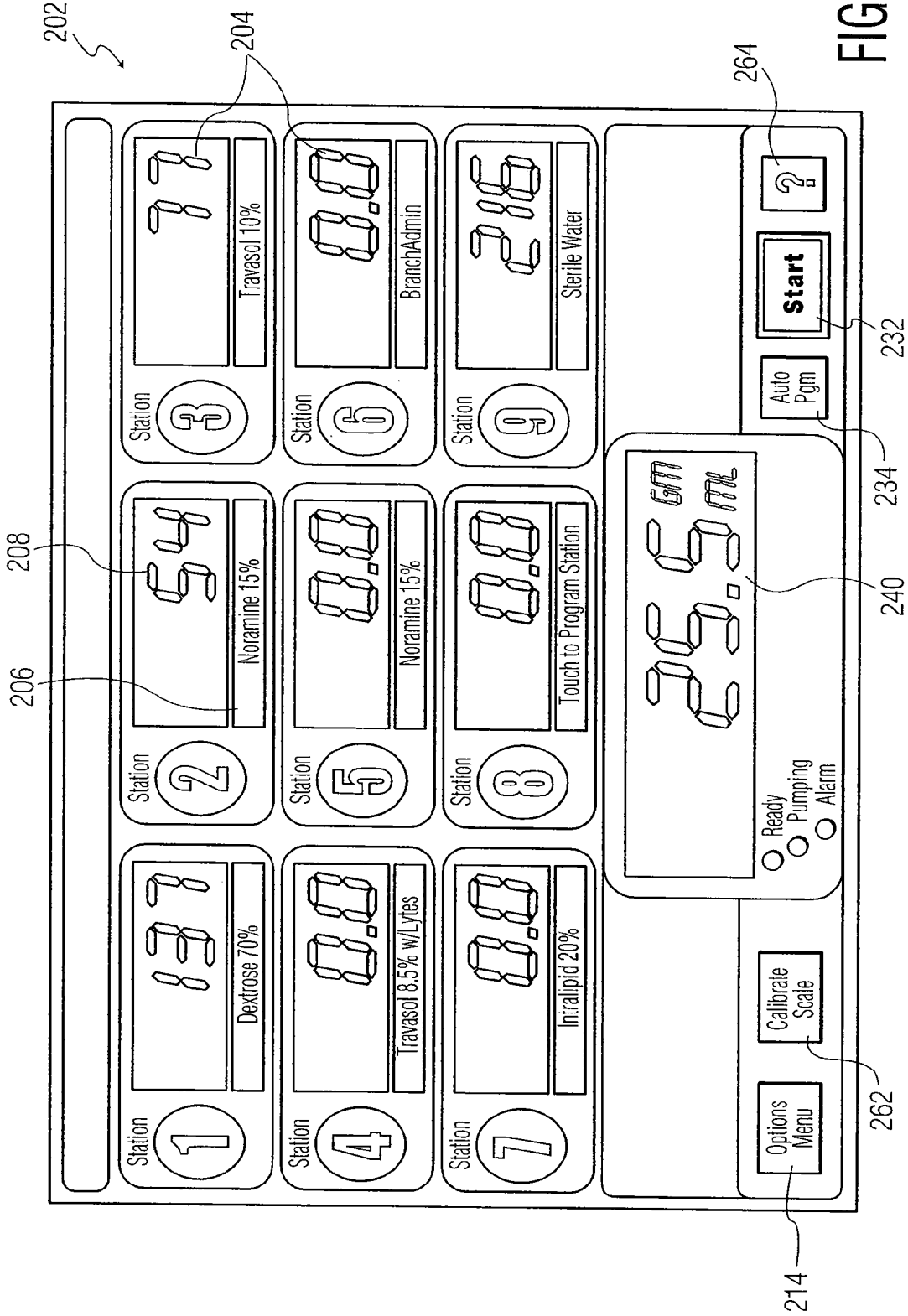

FIG. 9L

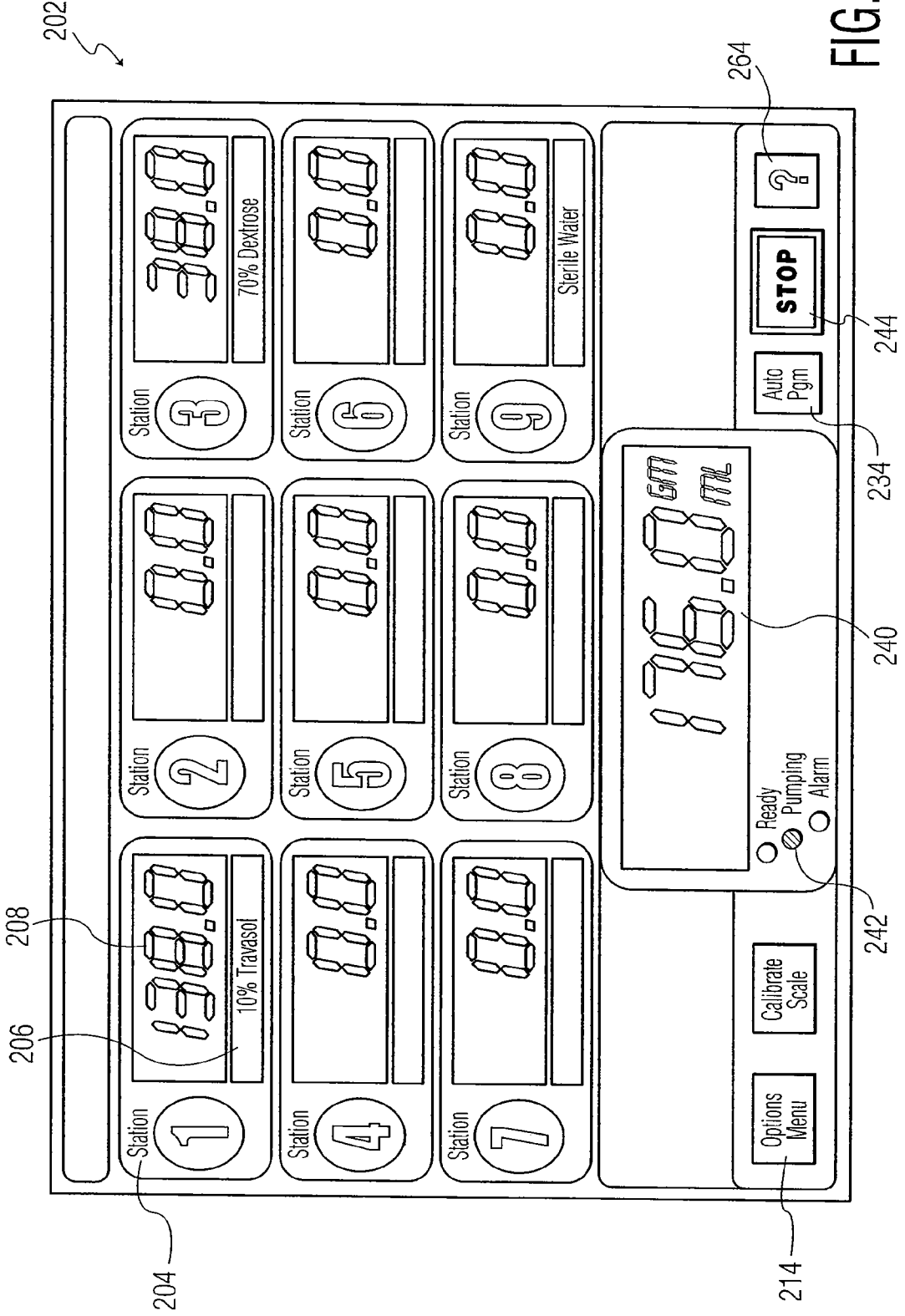

FIG. 9M

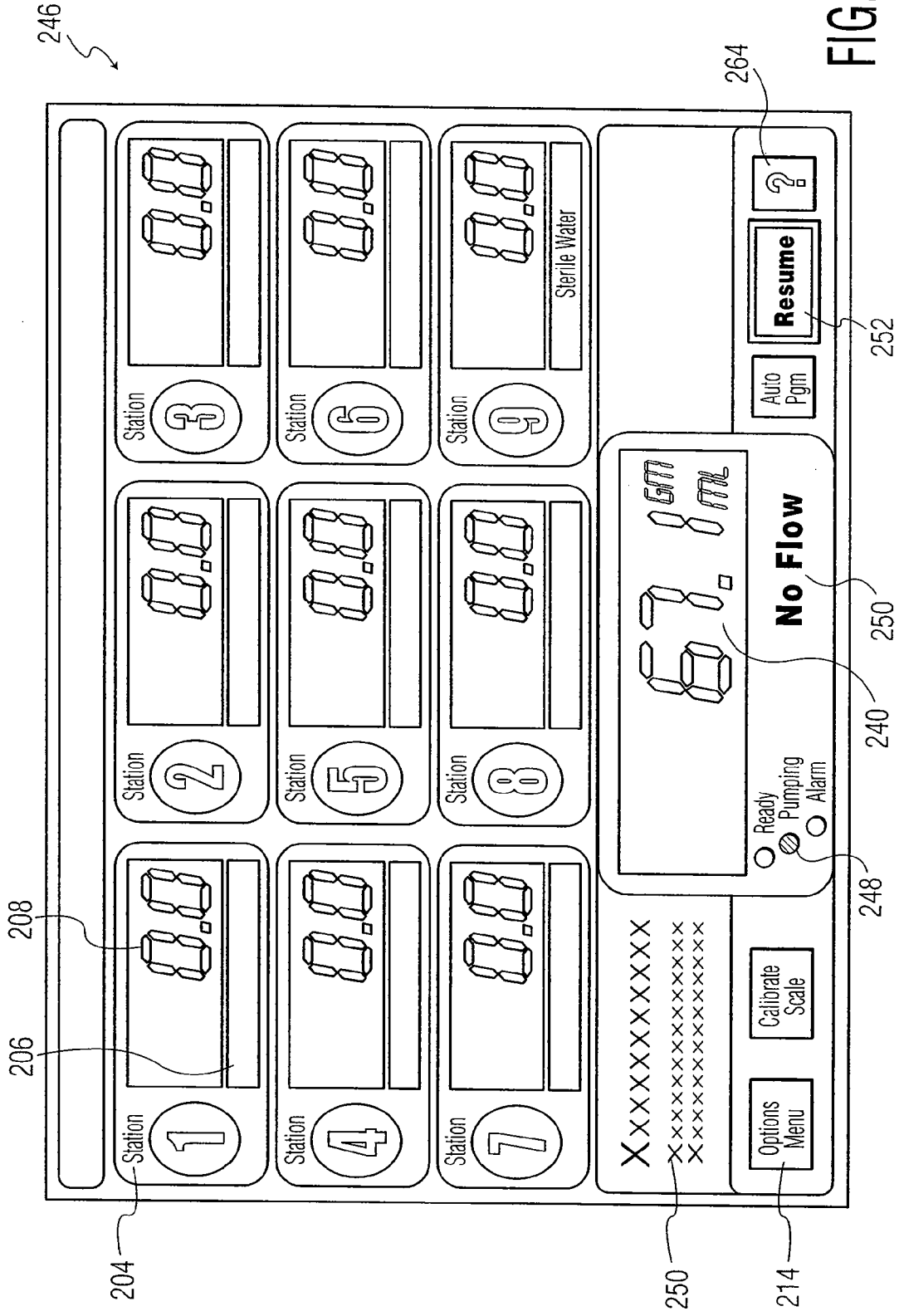

FIG. 9N

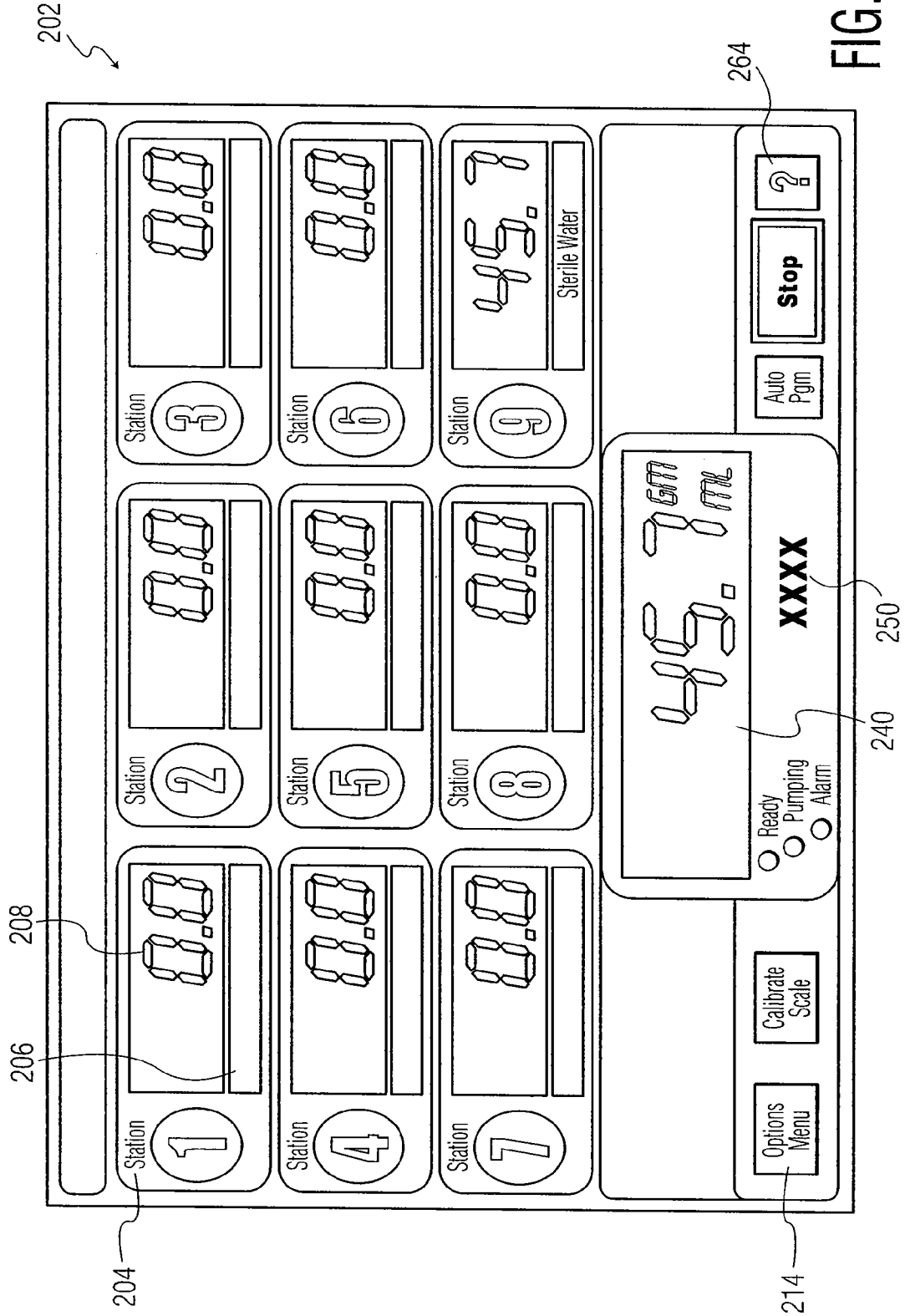

FIG. 90

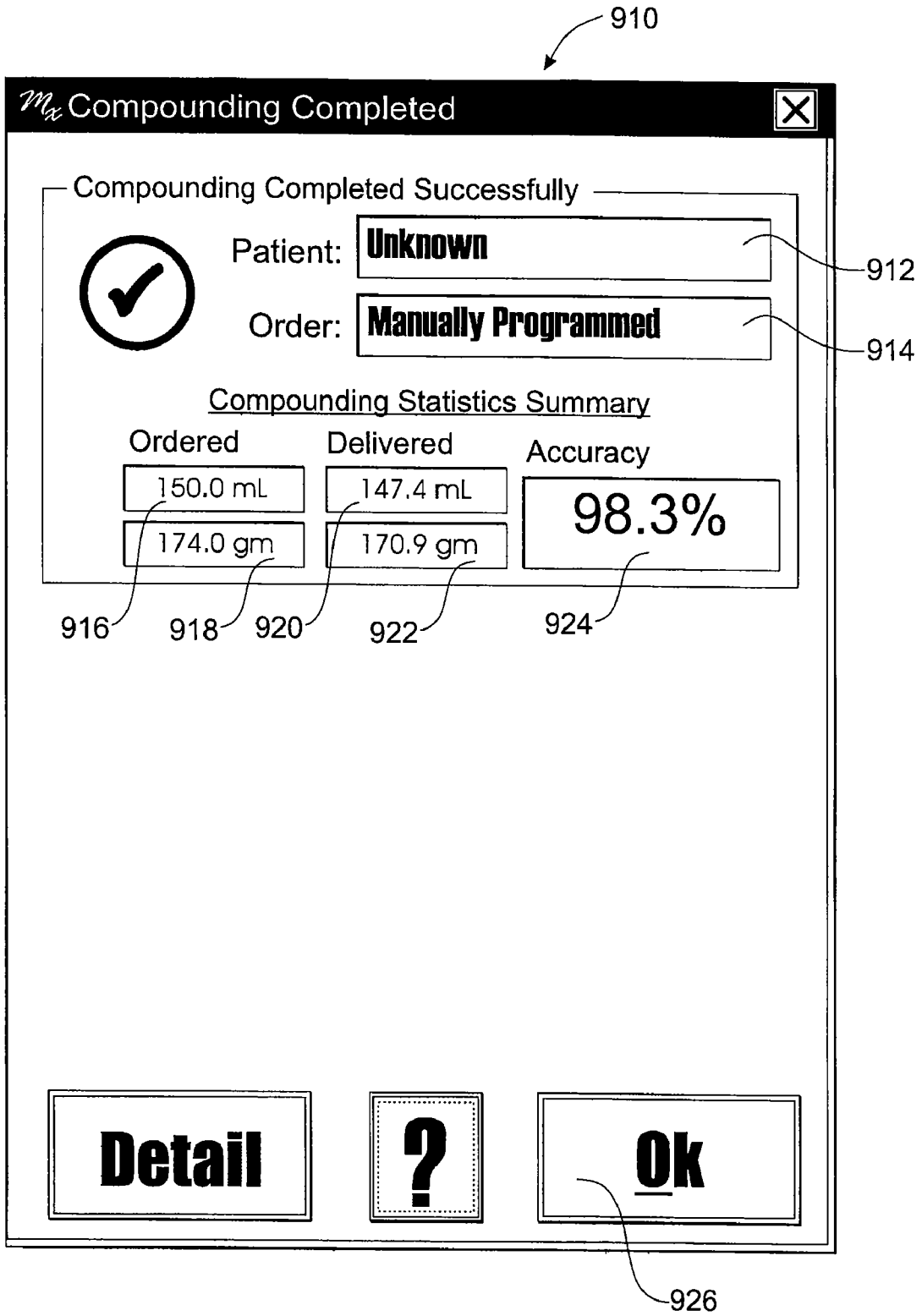

FIG. 90 (1)

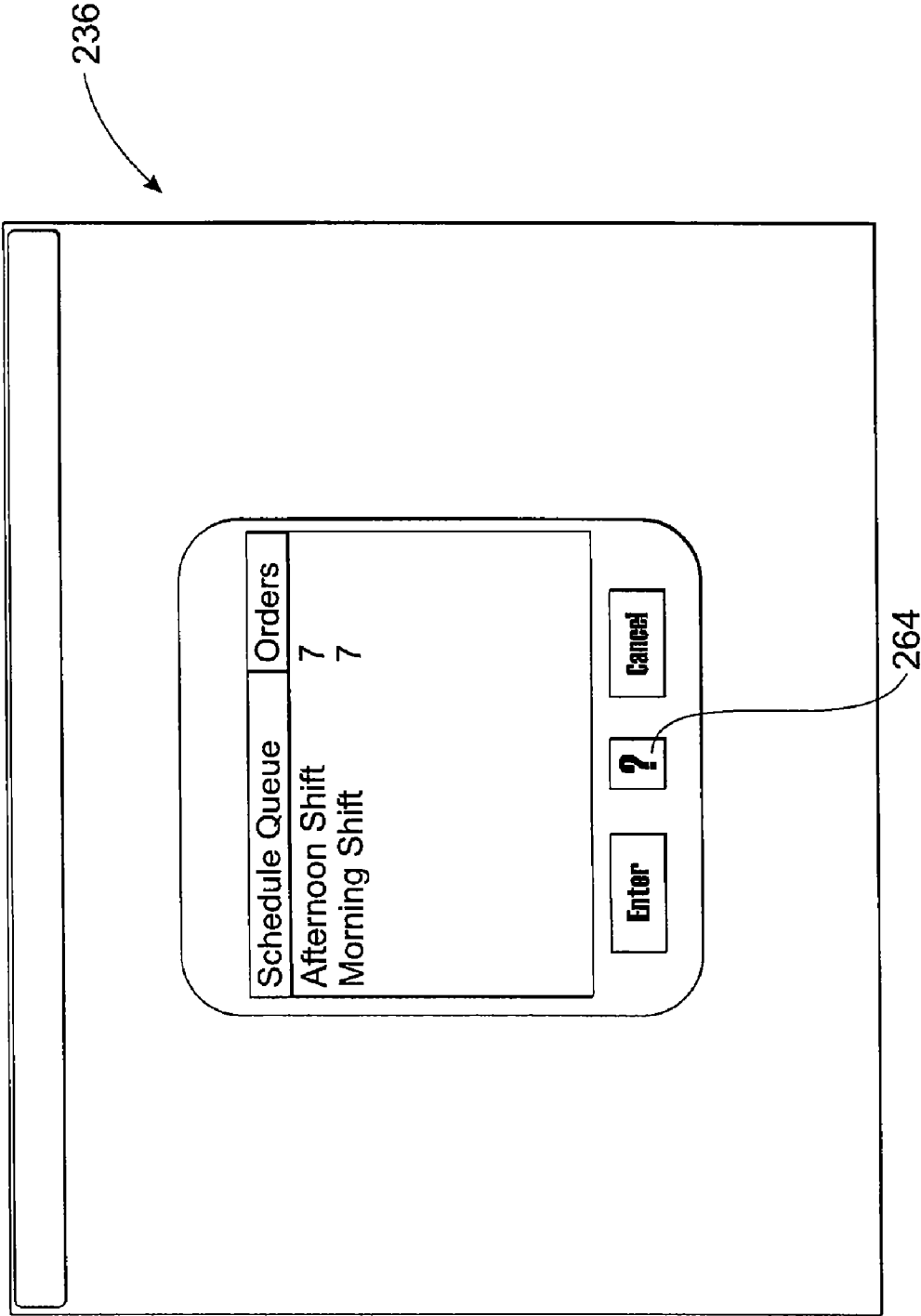

FIG. 9P

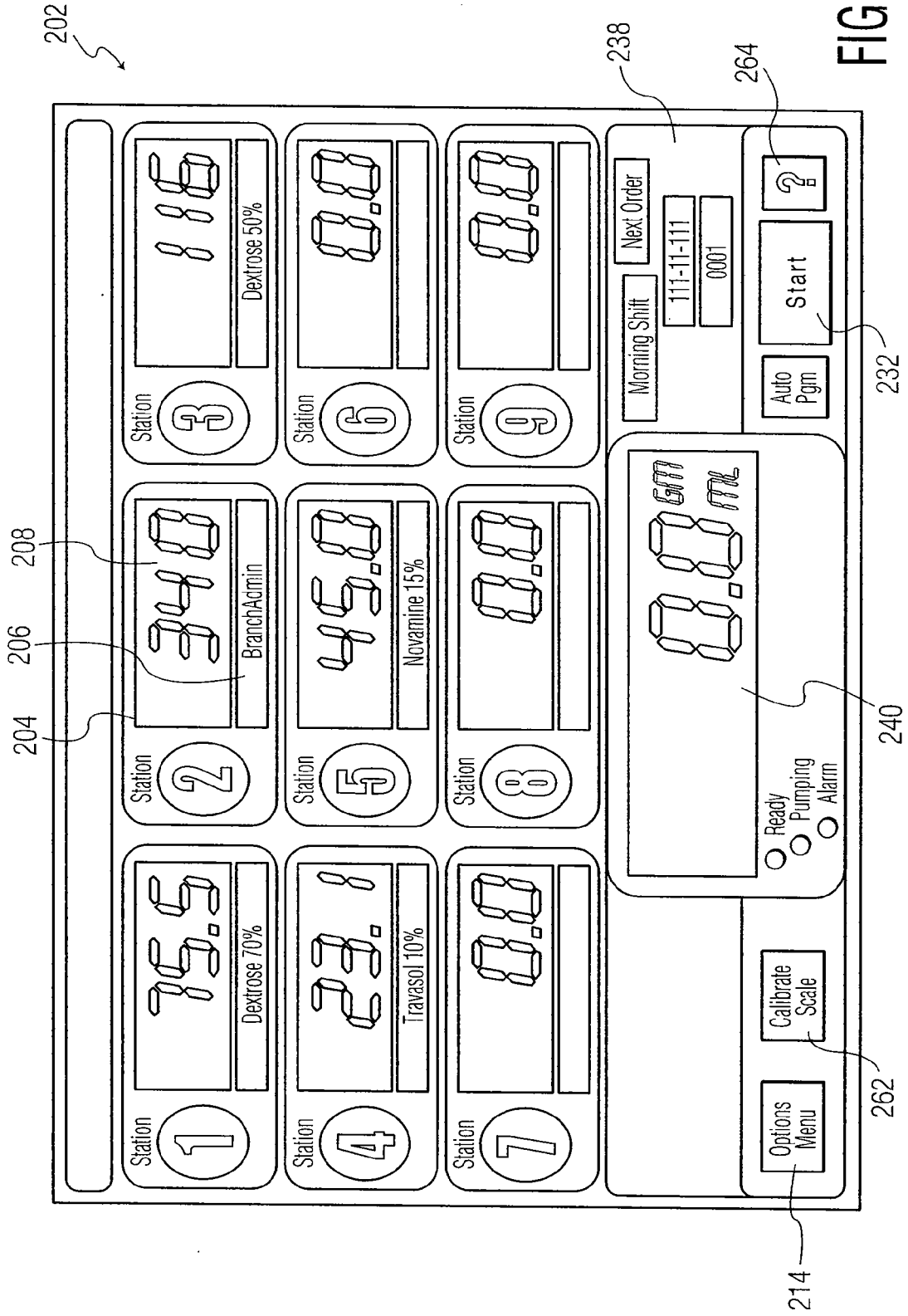

FIG. 90

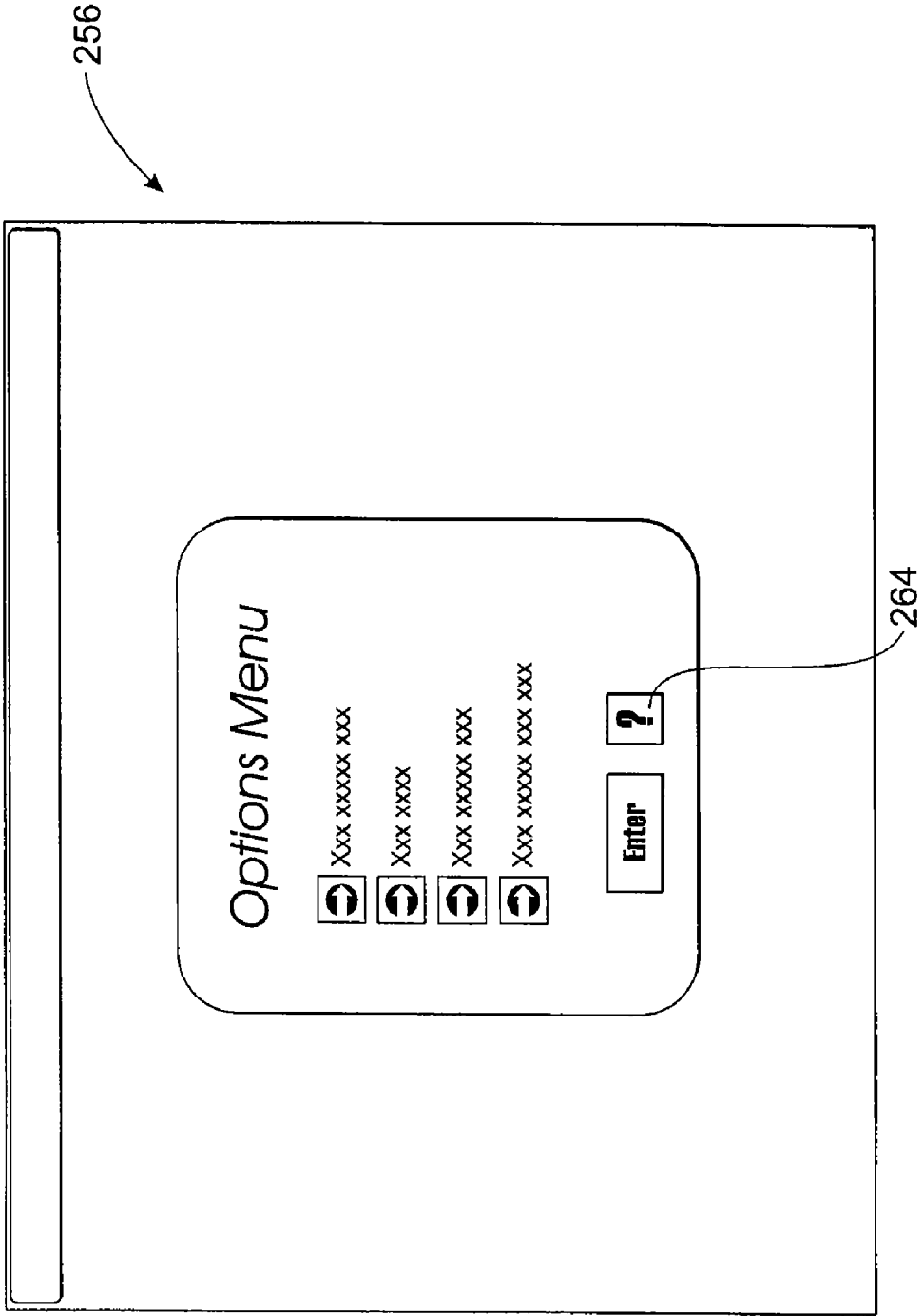

FIG. 9R

258

Date				
Search				
?				
Load This Order				
Exit				

Time	Type	Patient & Order #
12/11/2001 10:57:39 AM	Auto Pgm	123-45-6789 #12345
12/11/2001 10:53:49 AM	Manual	#002
12/11/2001 10:43:19 AM	Manual	#001

Order ID: Manual order 6001					
Start Time: 11/12/2001 11:22:31 AM → Completed Successfully					
ID	Solution	SPG	Sin	Dose	Actual Delivered
#00	Sterile Water	1.00	1	9999.9 mL	9999.9 mL
#00	Sterile Water	1.00	2	9999.9 mL	9999.9 mL
#00	Sterile Water	1.00	3	9999.9 mL	9999.9 mL
#00	Sterile Water	1.00	4	9999.9 mL	9999.9 mL
#00	Sterile Water	1.00	5	9999.9 mL	9999.9 mL
#00	Sterile Water	1.00	6	9999.9 mL	9999.9 mL
#00	Sterile Water	1.00	7	9999.9 mL	9999.9 mL
#00	Sterile Water	1.00	8	9999.9 mL	9999.9 mL
#00	Sterile Water	1.00	9	9999.9 mL	9999.9 mL
TOTALS				ALL	9999.9 mL

264

FIG. 9S

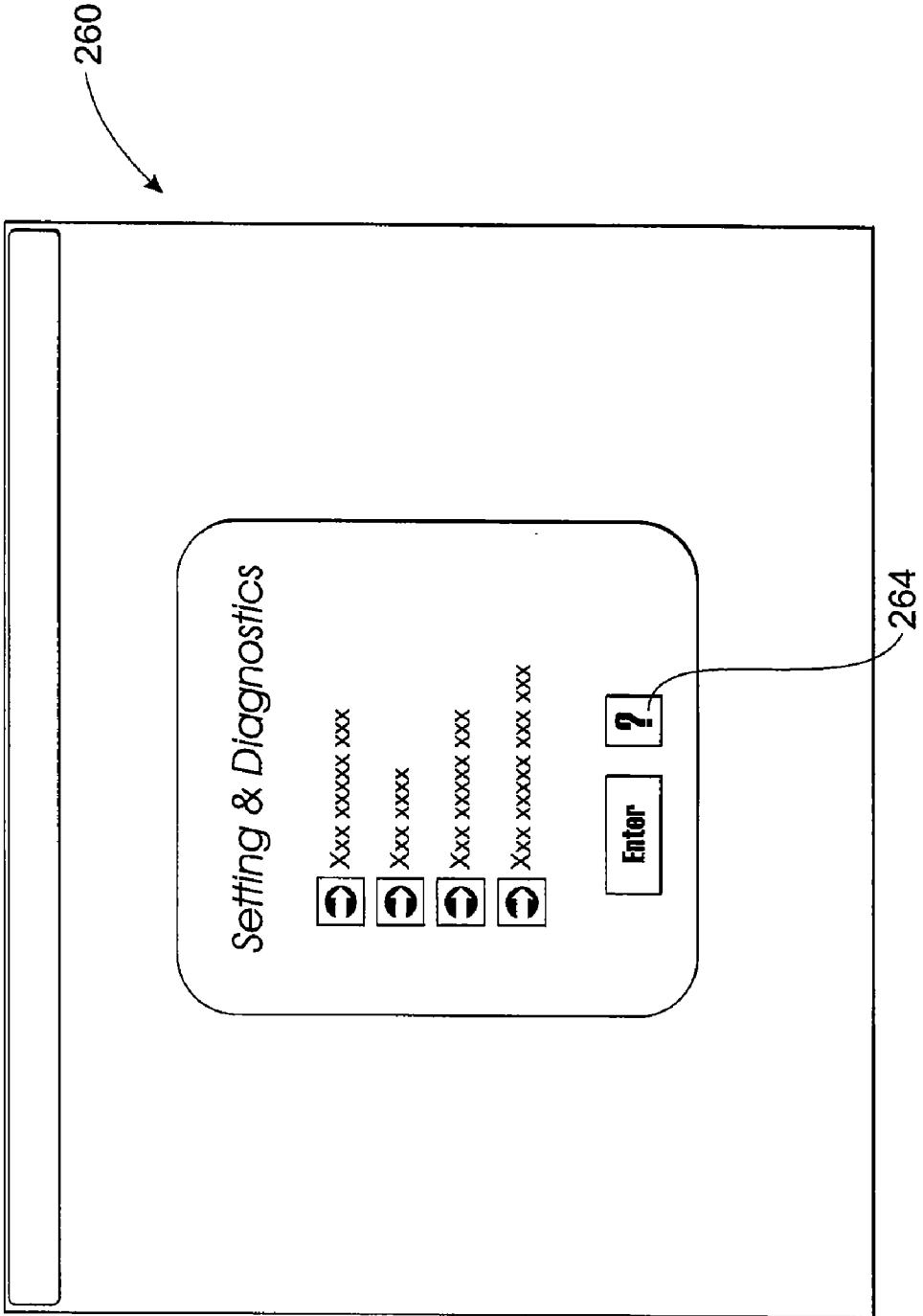

FIG. 9T

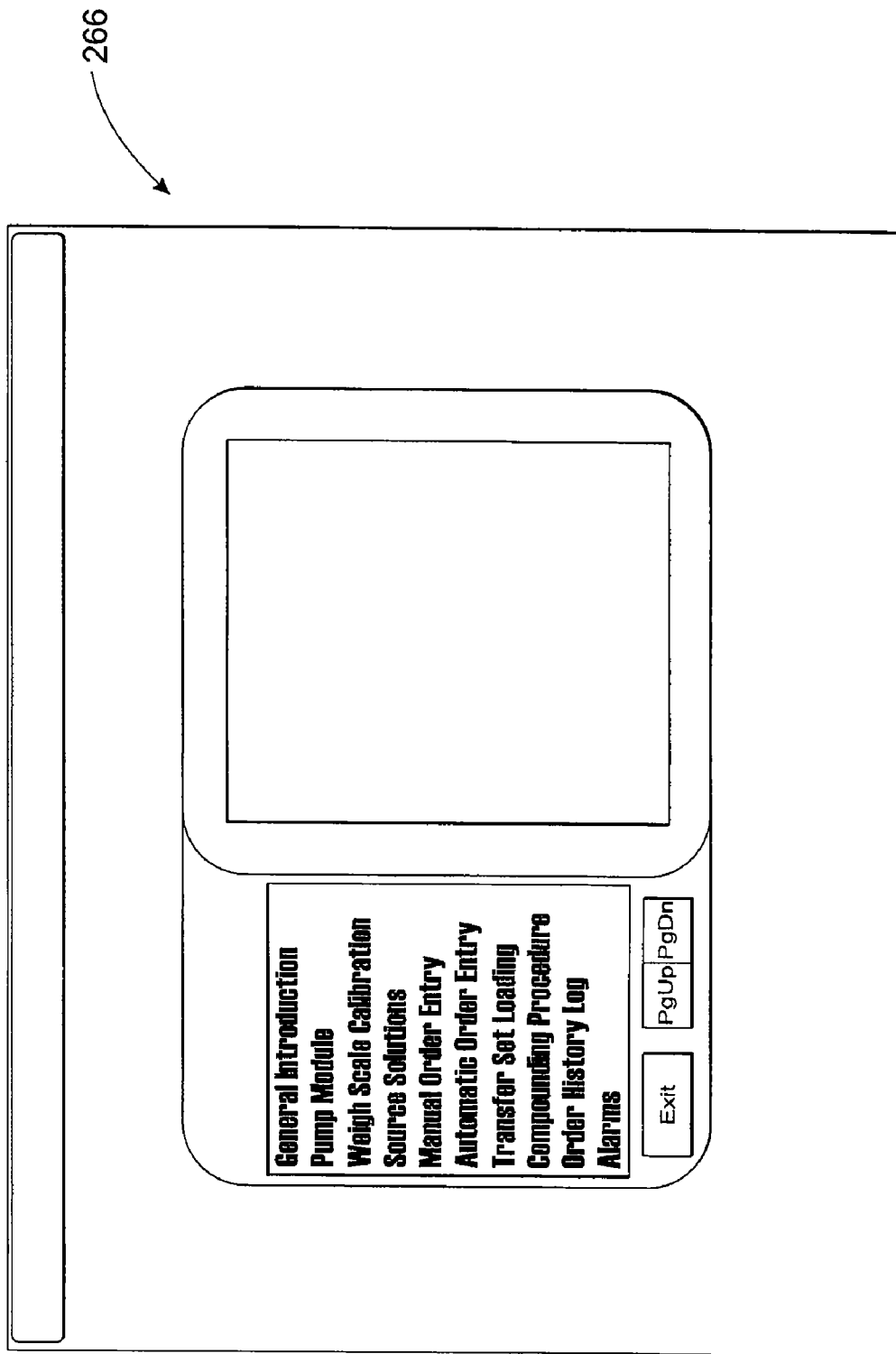

FIG. 9U

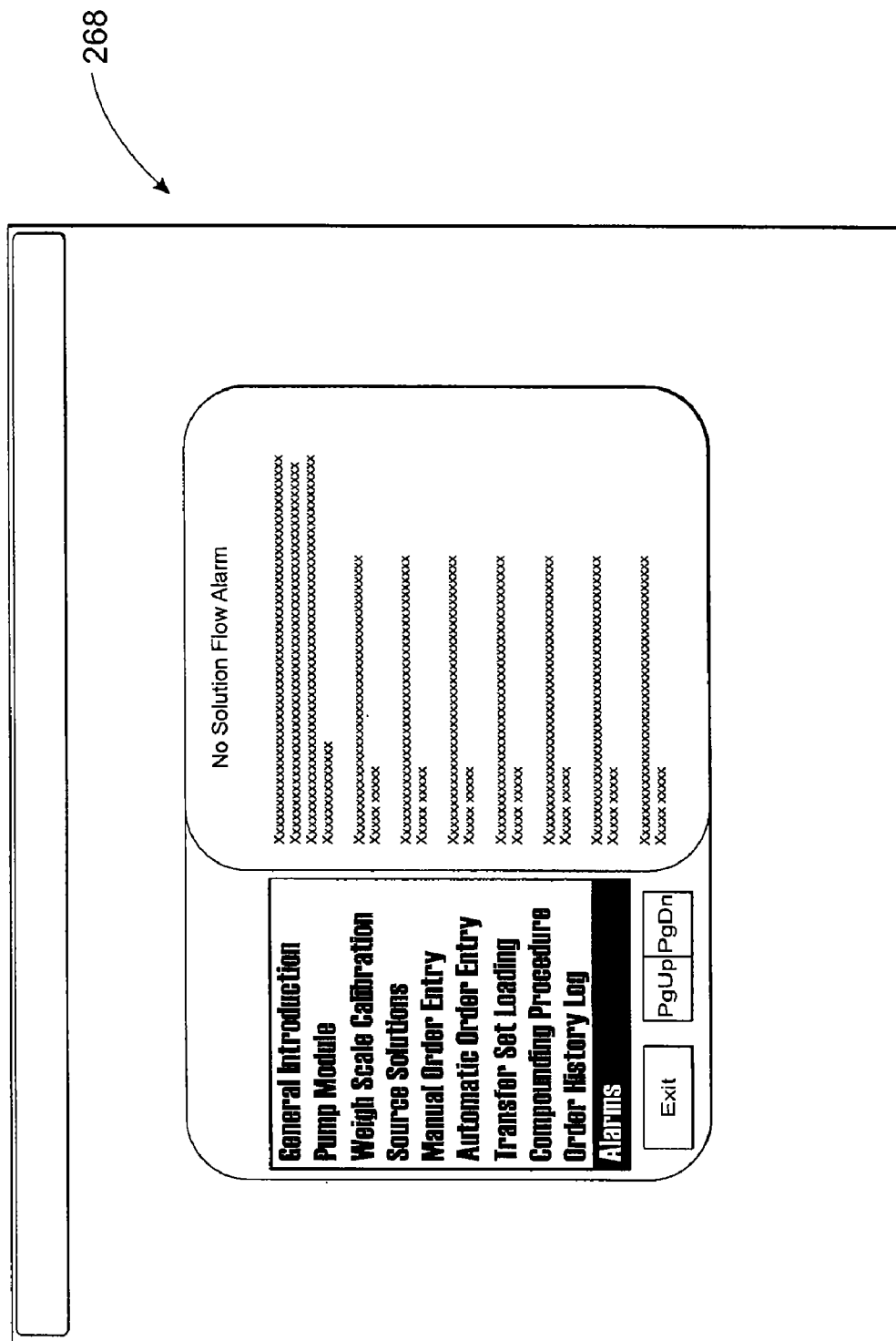

FIG. 9V

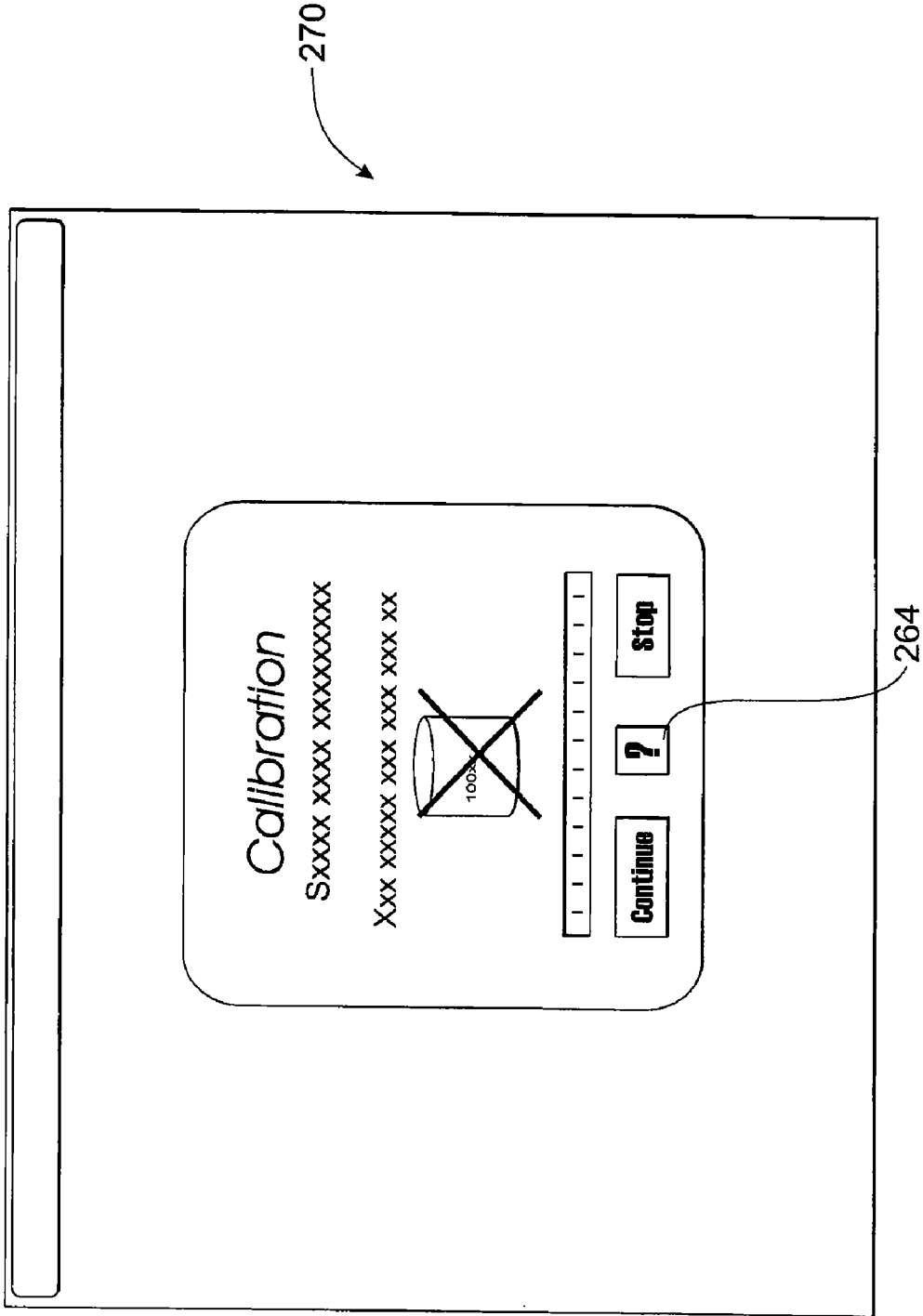

FIG. 9W

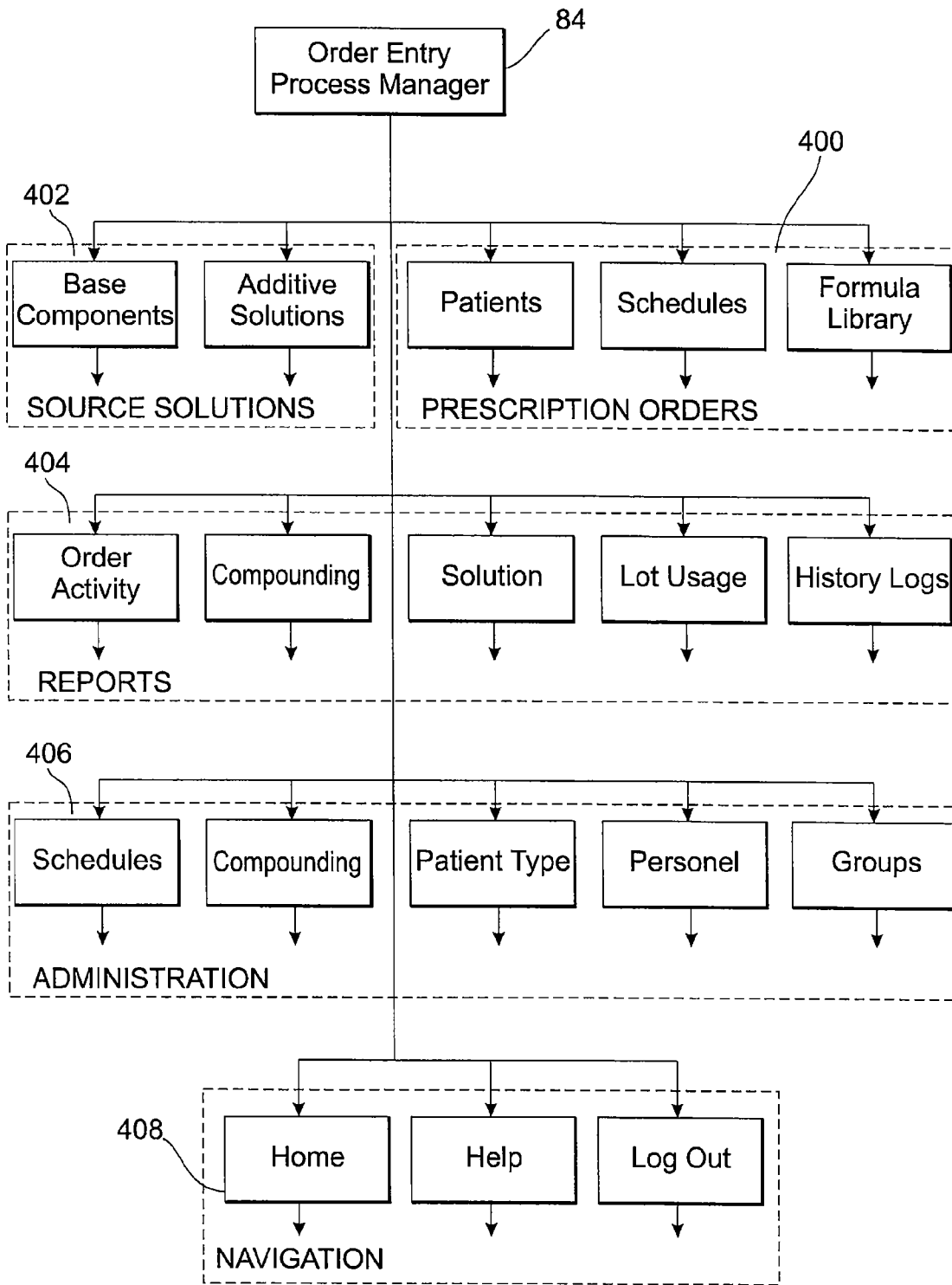
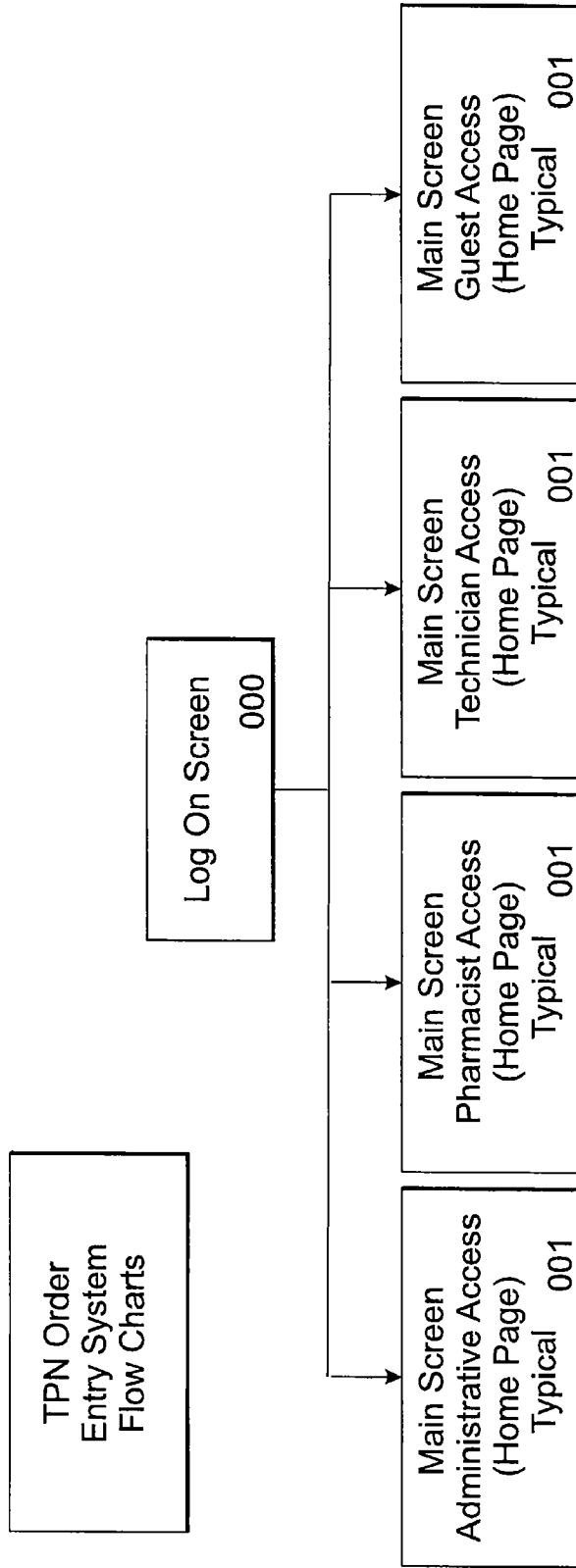

FIG. 10A(1)



Notes: Above access levels are "typical". Access to system functionality is a direct function of the individual's Granted access options.

Access titles (e.g., Administrative, Pharmacist, etc.) are not fixed and are instead examples of the type of levels that can be set up by the user.

Screen numbers are three digit code located in lower right corner of each flow chart box.

FIG. 10A(2)

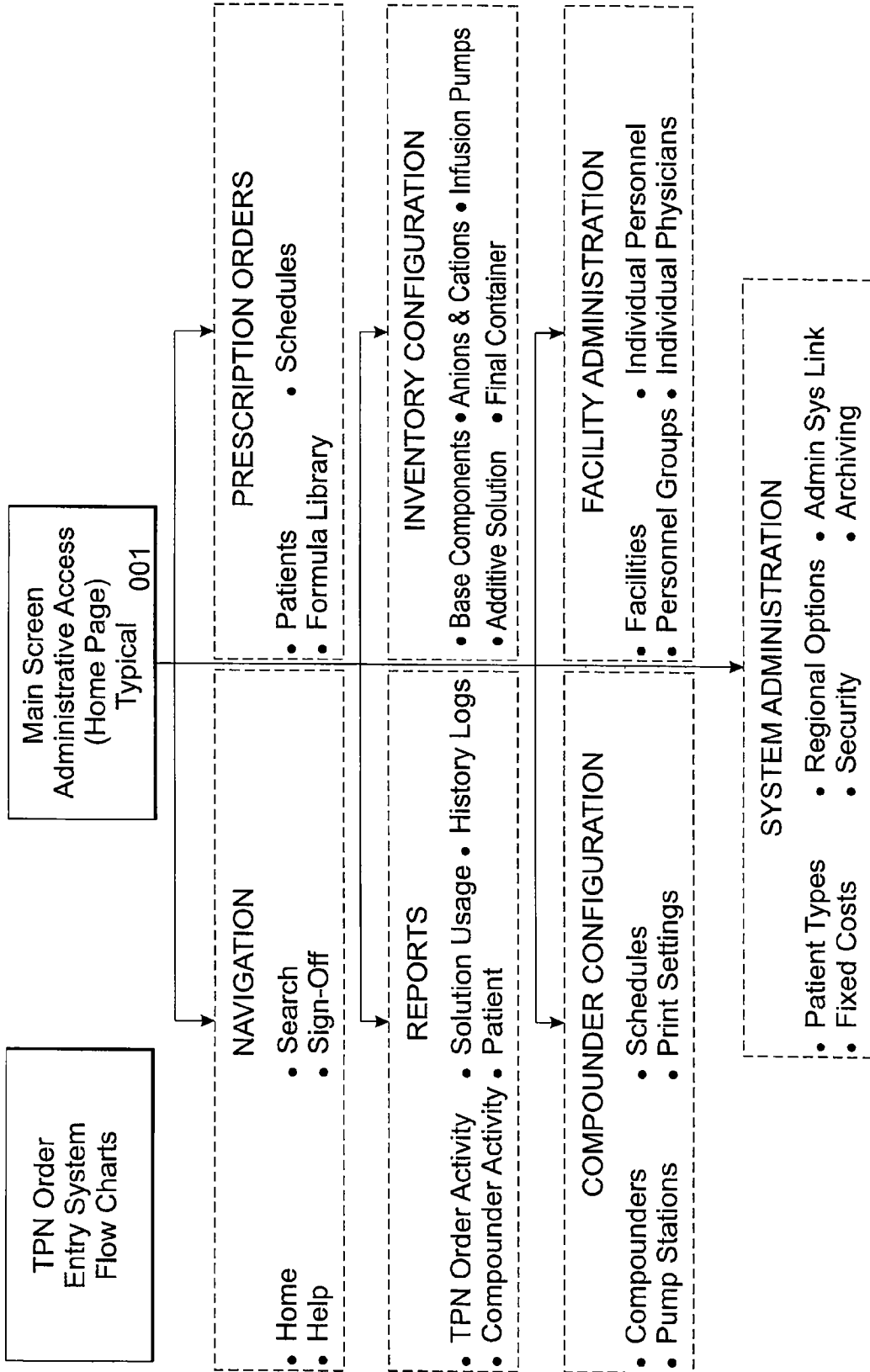

FIG. 10A(3)

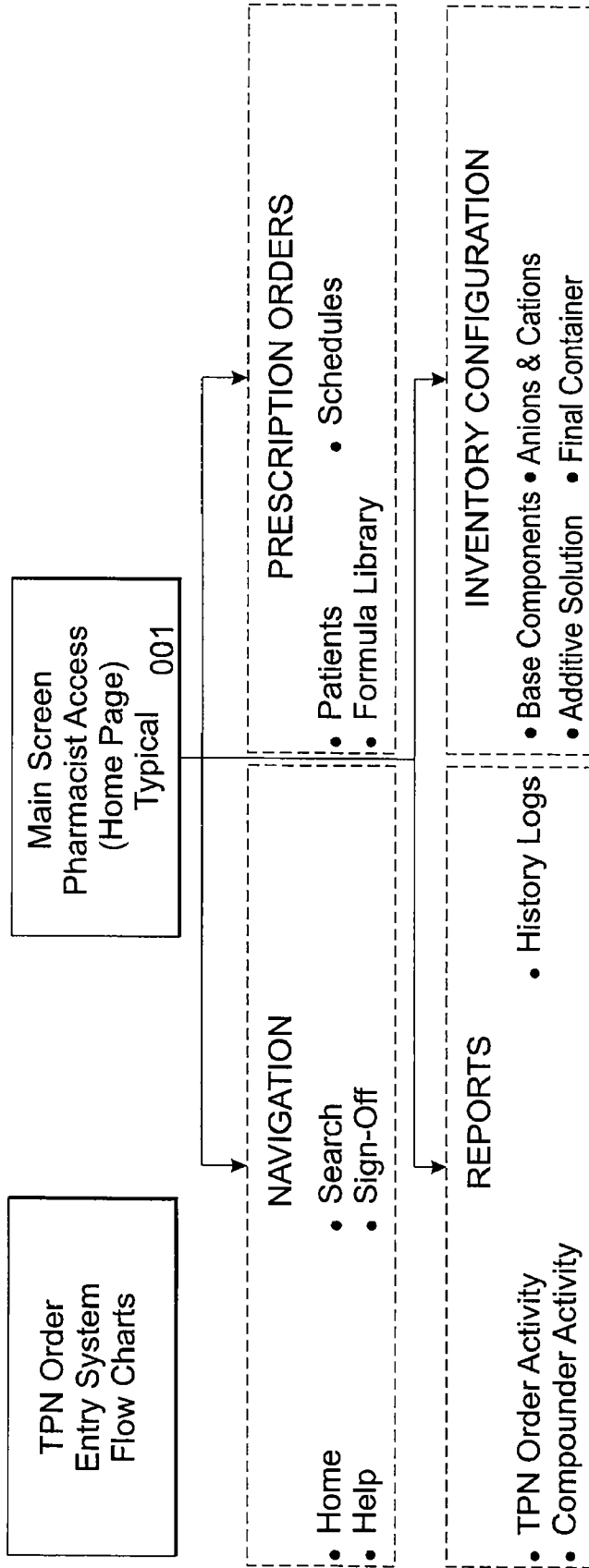

FIG. 10A(4)



FIG. 10A(5)

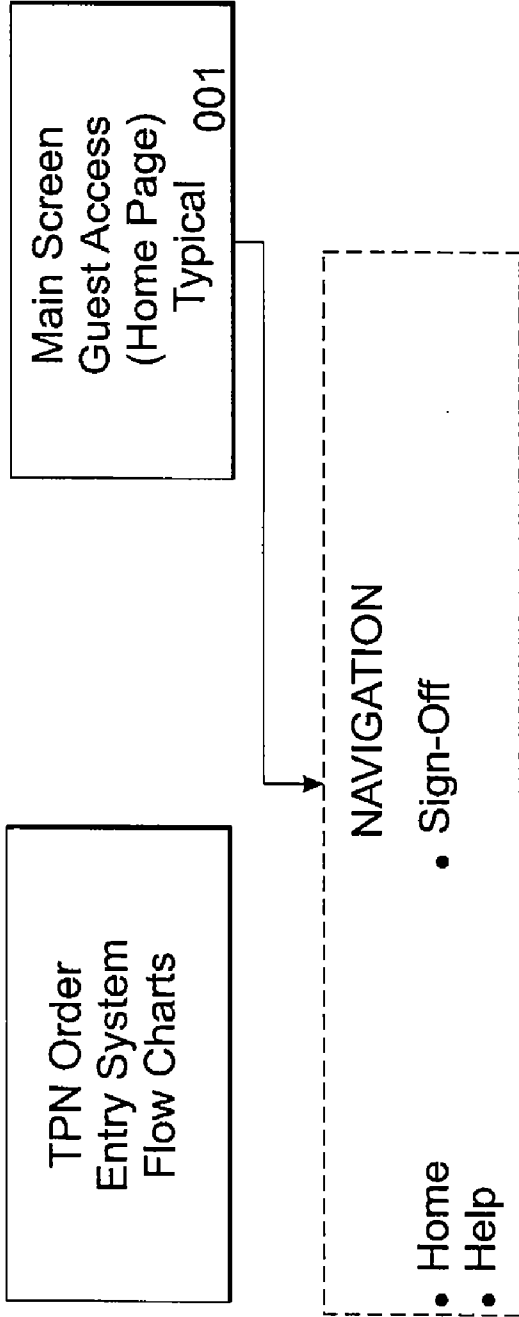

FIG. 10A(6)

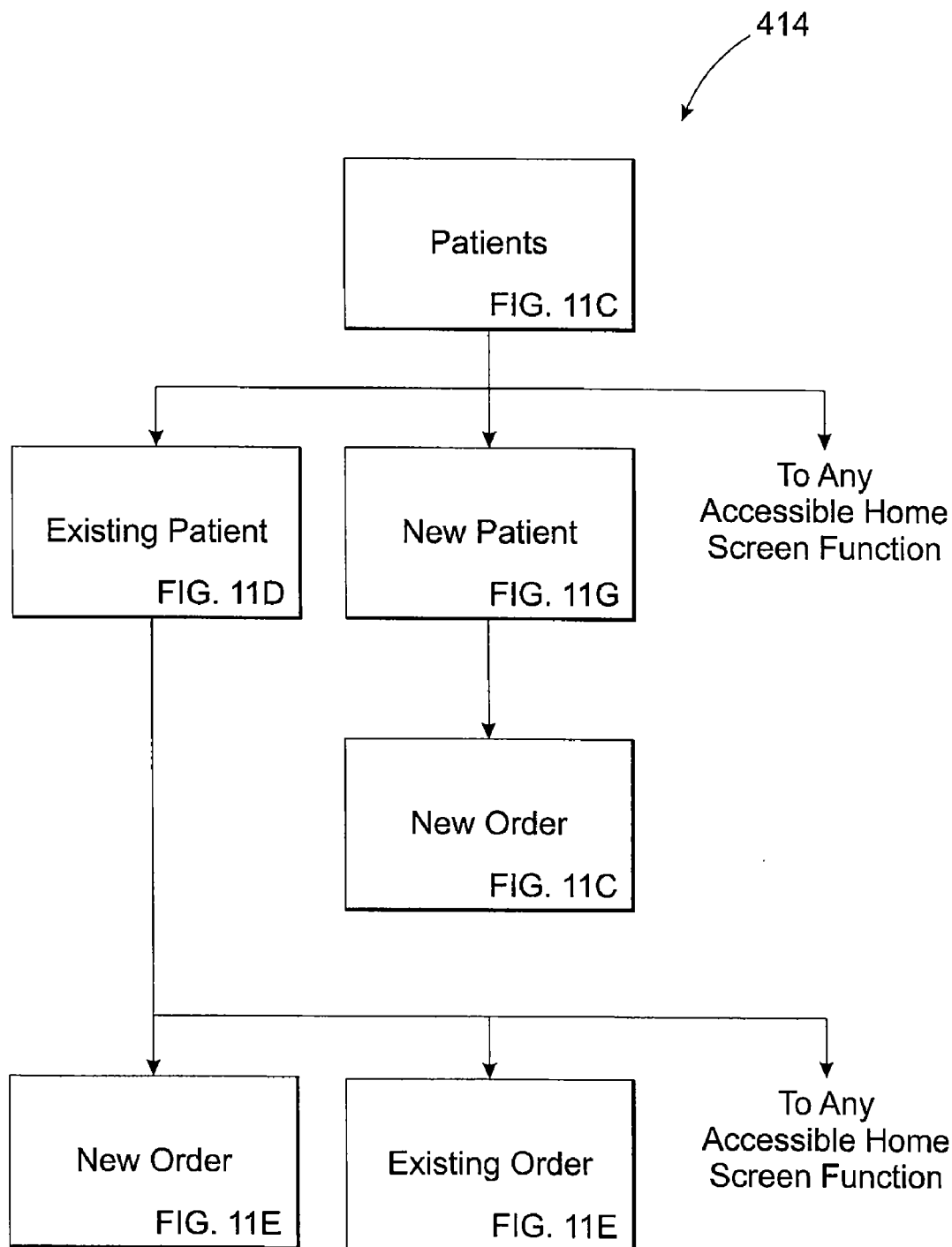

FIG. 10B

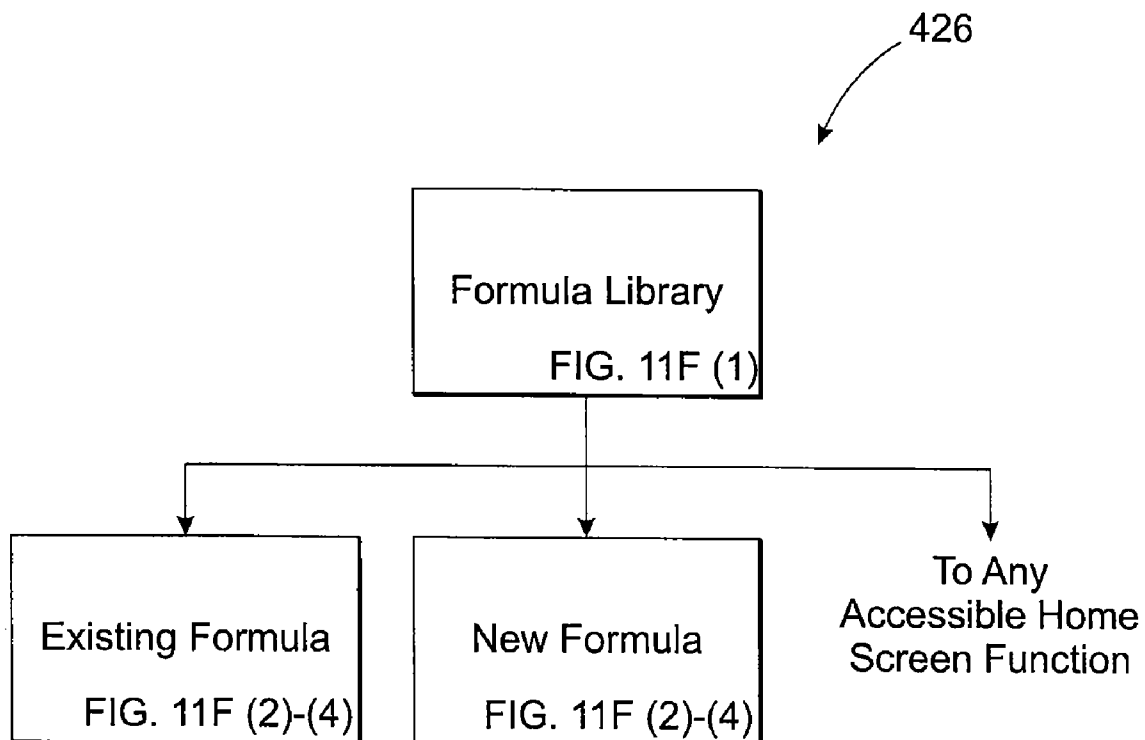

FIG. 10C

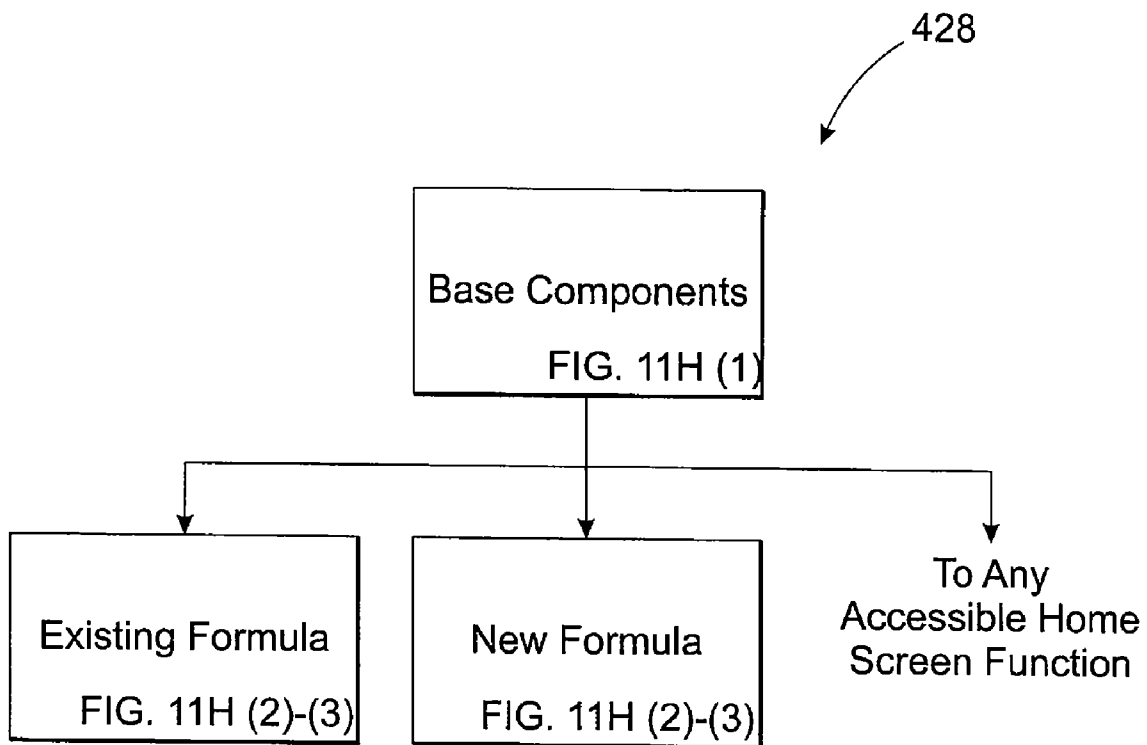

FIG. 10D

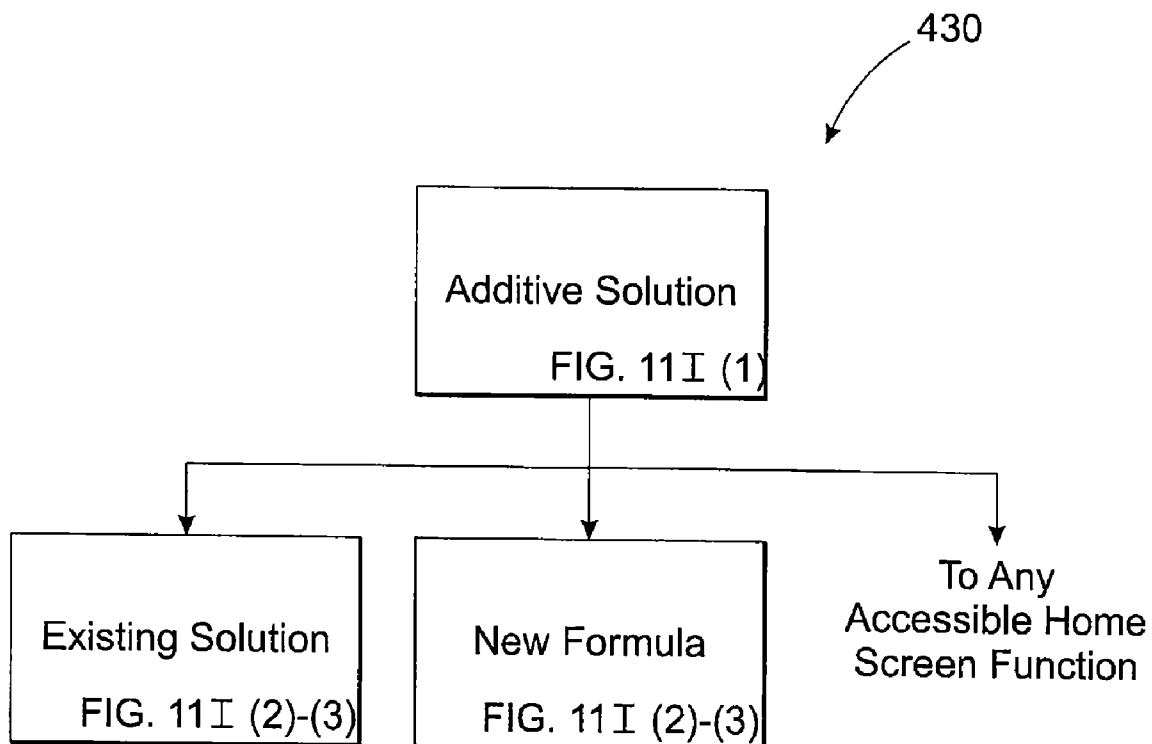

FIG. 10E

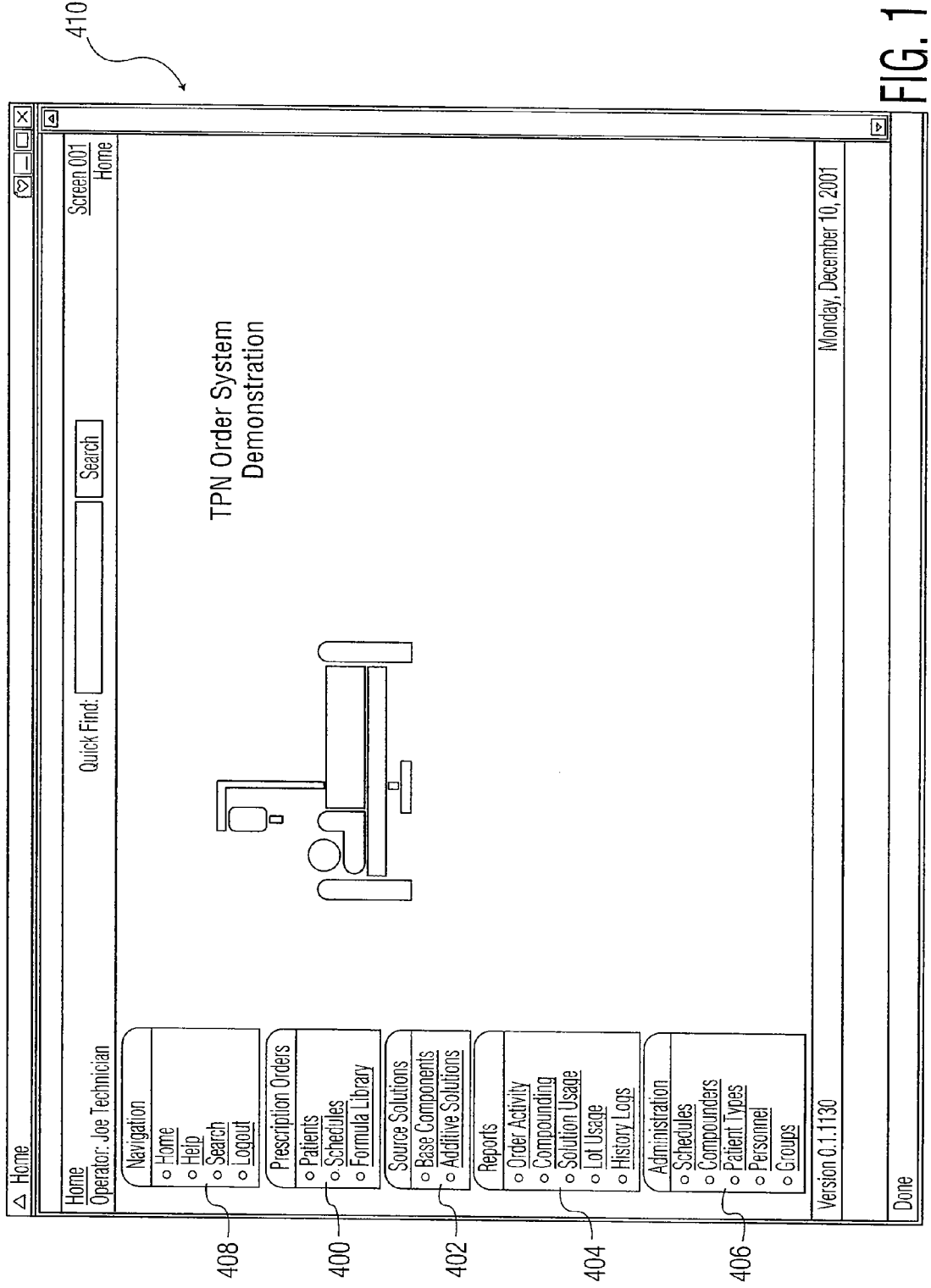

FIG. 11A

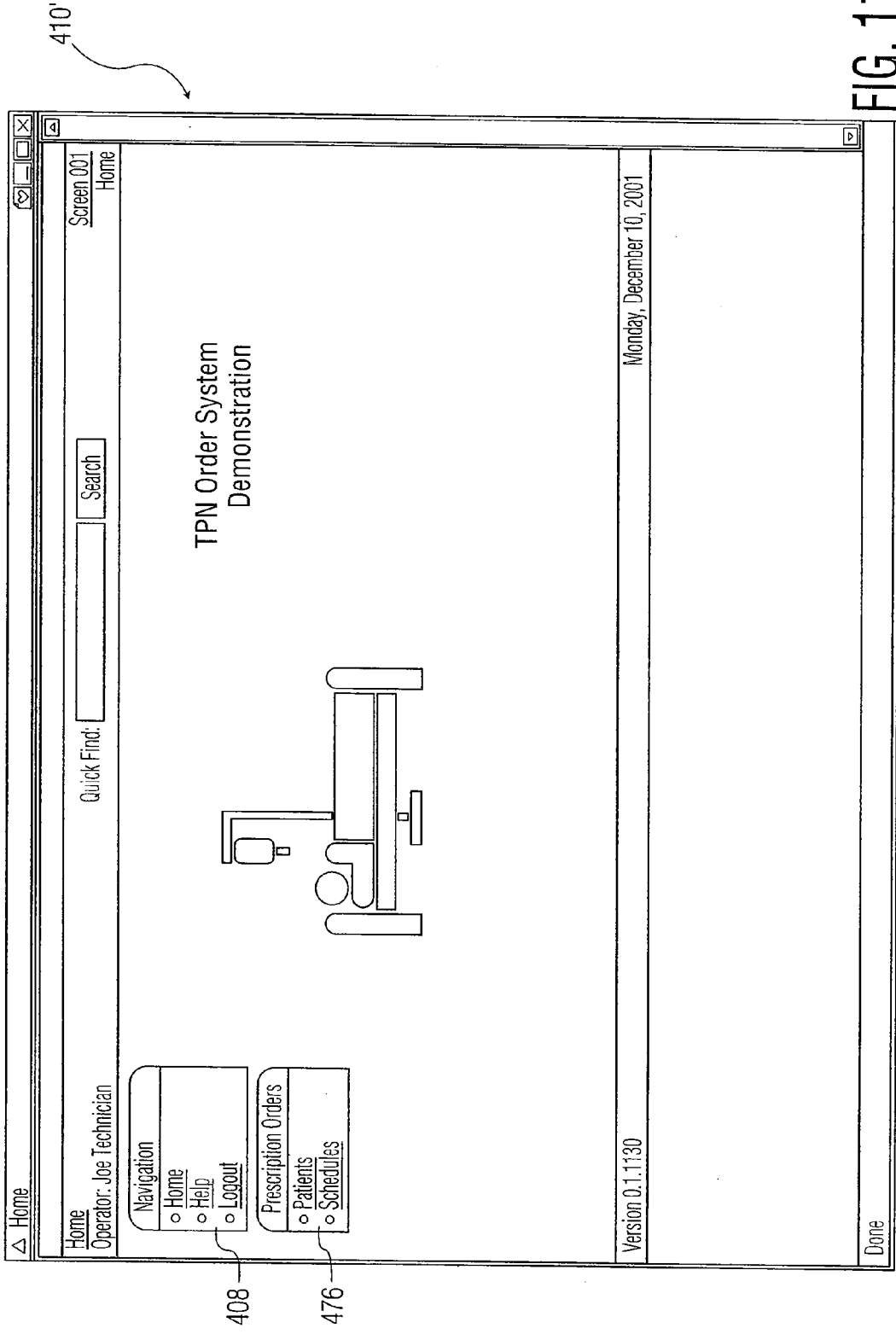

FIG. 11B

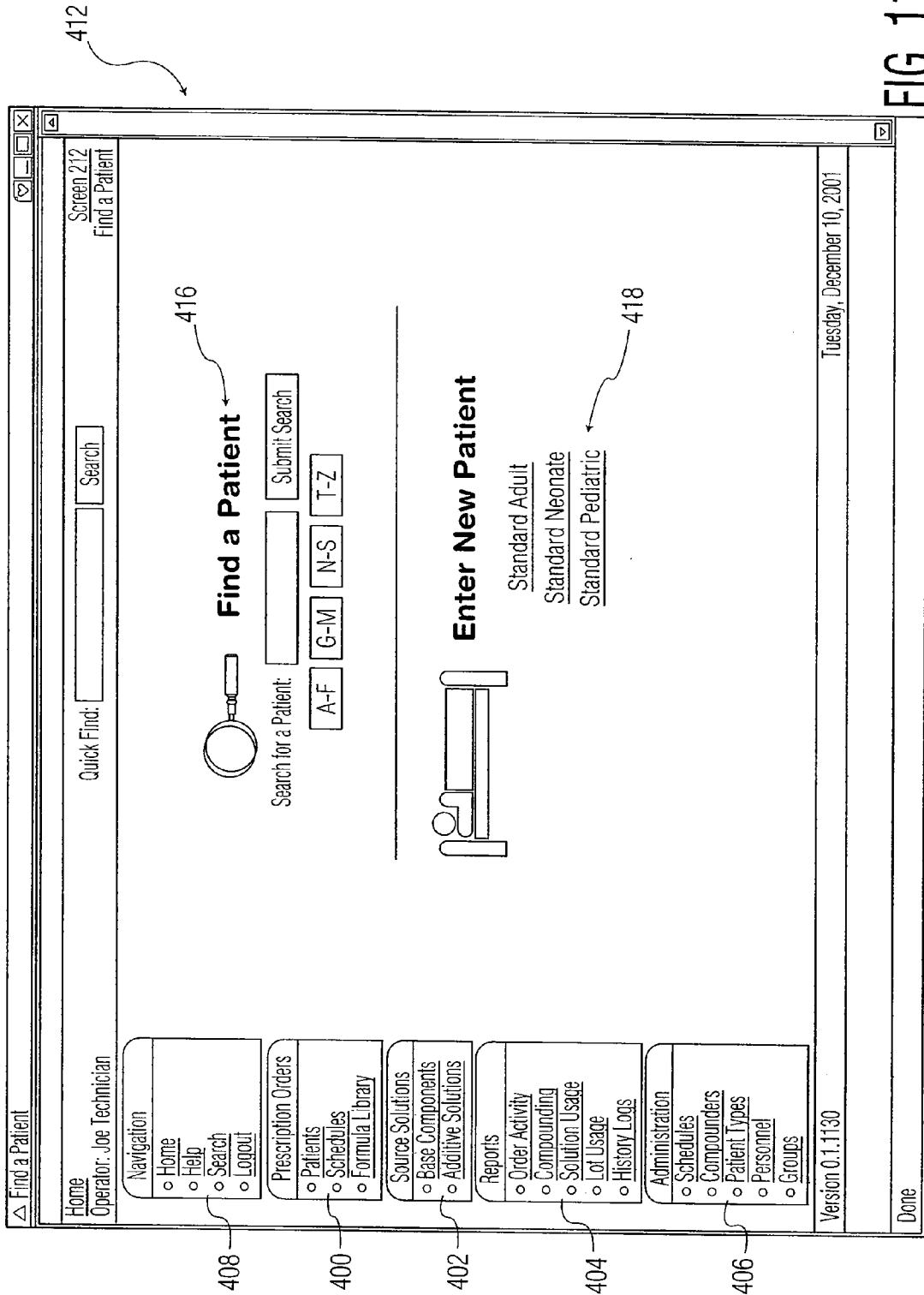

FIG. 11C

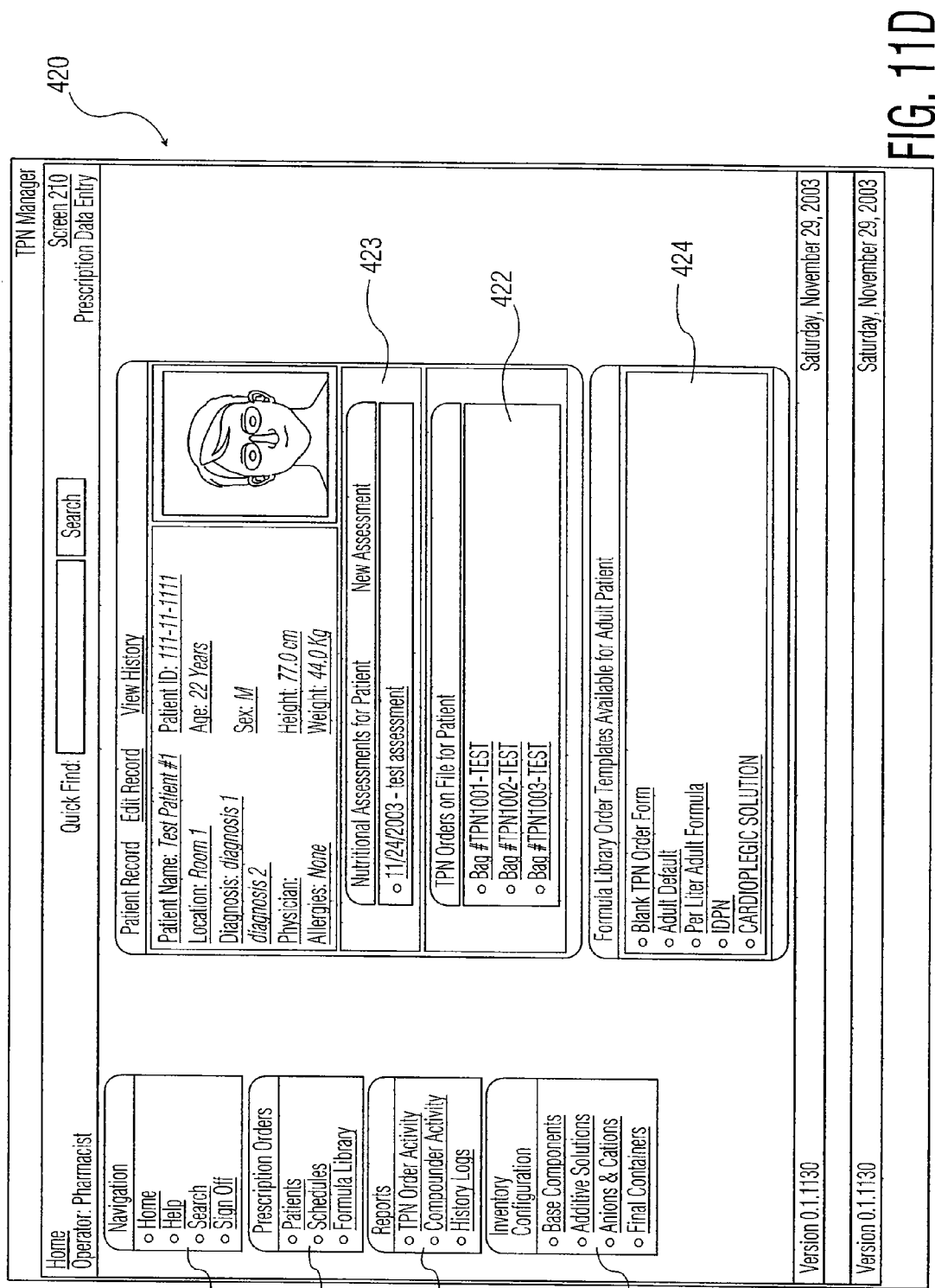



FIG. 11D

△ TPN Order Entry
Screen 3.10
TPN Order Entry

Home
Operator: Joe Technician
Data Entry



TPN Order Entry

Edit Patient Record



Patient Information

Patient Name: <i>Test Patient #1</i>	Patient ID: <i>111-11-1111</i>
Location: <i>Room 222, Bed 1</i>	Age: <i>22 Years</i>
Diagnosis: <i>Fever</i>	Sex: <i>Male</i>
Physician: <i>Dr. Smith</i>	Height: <i>86.0 cm</i>
Allergies: <i>None</i>	Weight: <i>34.0 Kg</i>

I.V. Container Information

Prescription Order

Order Number: <input type="text" value="Container 1"/>	Bag No: <input type="text" value="0001"/>	Order History: <i>12/09/2001 13:02:28 (rsp) Changed TPN Order</i>
Intusion Volume: <input type="text" value="2000"/> mL or <input type="checkbox"/> Minimum Possible	Intusion Ratio: <input type="text" value="125.00"/> mL / Hour	Intusion Period: <input type="text" value="9:20"/> Hours
Overfill Volume: <input type="text" value="0"/> mL	Delivery Date: <input type="text" value="06/26/2001"/>	Delivery Time: <input type="text" value="8:00 AM"/>

Container Label Notes: final notes

Worksheet Label Notes: worksheet notes

Done

FIG. 11E(1)

436

TPN Order Entry

Base Components

Instructions	Base Component	Order Dose	mL	Edit
	Dextrose 70%	222.00 mL	75.5	change
	BranchAmin	93.10 mL	186.2	change
	Dextrose 50%	5.00 %	200.0	change
	Travasol 10%	106.90 mL	213.8	change
	Intralipid 10% PF 250 mL	250.0 mL Pre-Filled Container	250.0	change

Add Solution to Order

Branched Chain Calculator

Solution Order Dose mL Per

Pre-Fill Container: Piggyback Final Container

Click to Submit Base Component Changes or Additions

Additives

Instructions	Additive Solution	Order Dose	mL	Edit
	Potassium Chloride	20.00 mL	40.0	change
	Sodium Acetate	30.00 mL	10.2	change
	Zinc	0.50 mL	0.2	change
	Heparin	1000.00 unit	34.0	change
	Aminophylline	1.00 mL	30.8	change
	Sodium Chloride	15.00 mEq	60.0	change

Click to Submit Base Component Changes or Additions

Done

440

442

FIG. 11E(2)

436

440

444

TPN Order Entry

Additives

Instructions	Additive Solution	Order Dose	mL	Edit
	Potassium Chloride	20.00 mL /Lier	40.0	change
	Sodium Acetate	30.00 mL /100Kg	10.2	change
	Zinc	0.50 mL /100Kg	0.2	change
	Heparin	1000.00 unit /Kg-I	34.0	change
	Aminophylline	1.00 mL /Lb-I	30.8	change
	Sodium Chloride	15.00 mEq /500ml	60.0	change

Add Solution to Order

Solution Order Dose Per

Click to Submit Additive Changes or Additions

Nutritional Summary

<p><u>Nutritional Content Summary</u></p> <p>4.18 gm Nitrogen 118.195 Kcal Protein 522.445 Kcal Dextrose 275.000 Kcal Lipid 915.640 Kcal Total Total Volume 2000.0 mL</p>	<p><u>Electrolyte Content Summary</u></p> <p>0 mEq NA+ 0 mEq K+ 0 mEq CA++ 0 mEq MG++ 0 mEq CL- 0 mMol PO4-- 0 mEq AC- Osmolarity 14117.4</p>
--	--

Order Status

Done

FIG. 11E(3)

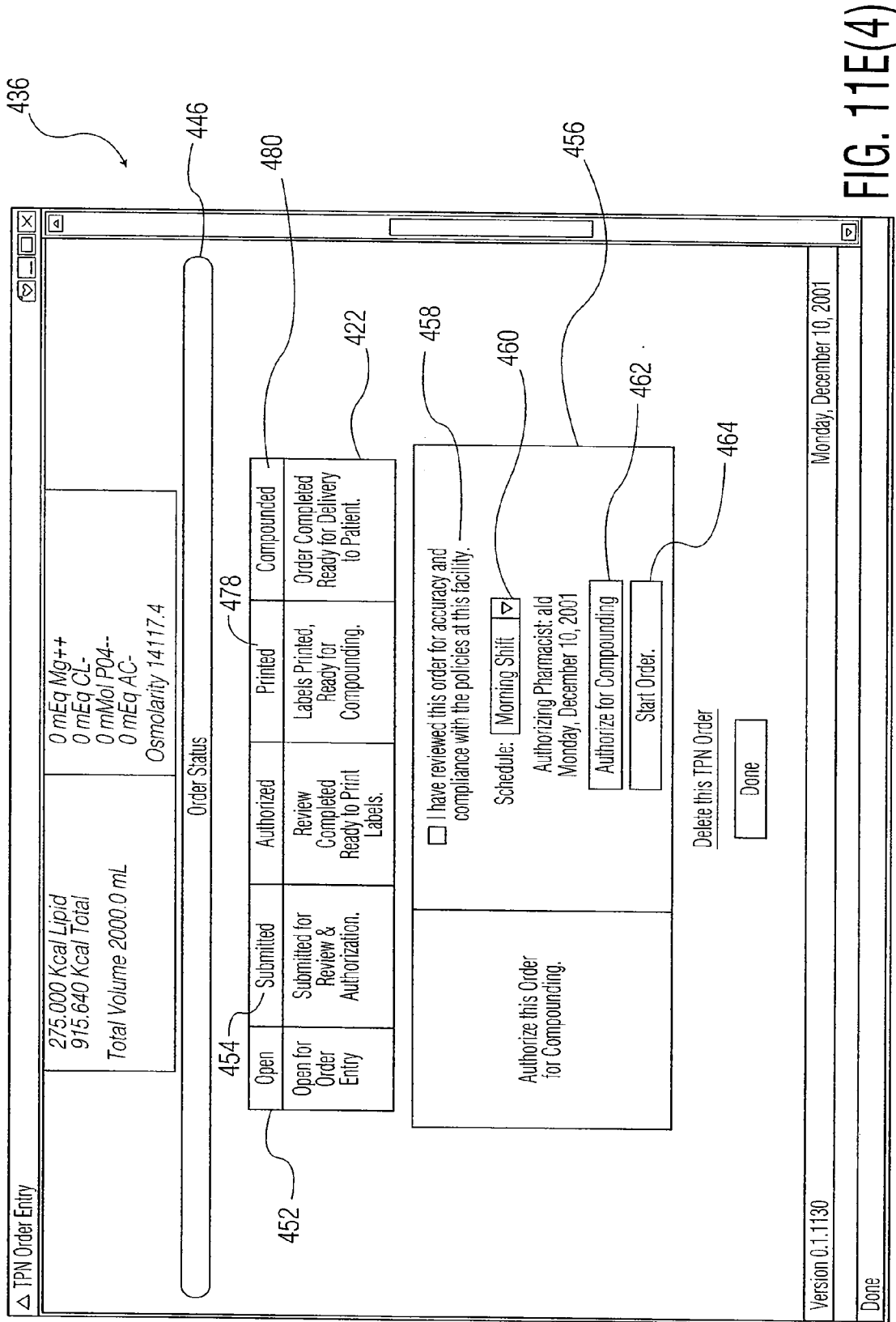

FIG. 11E(4)

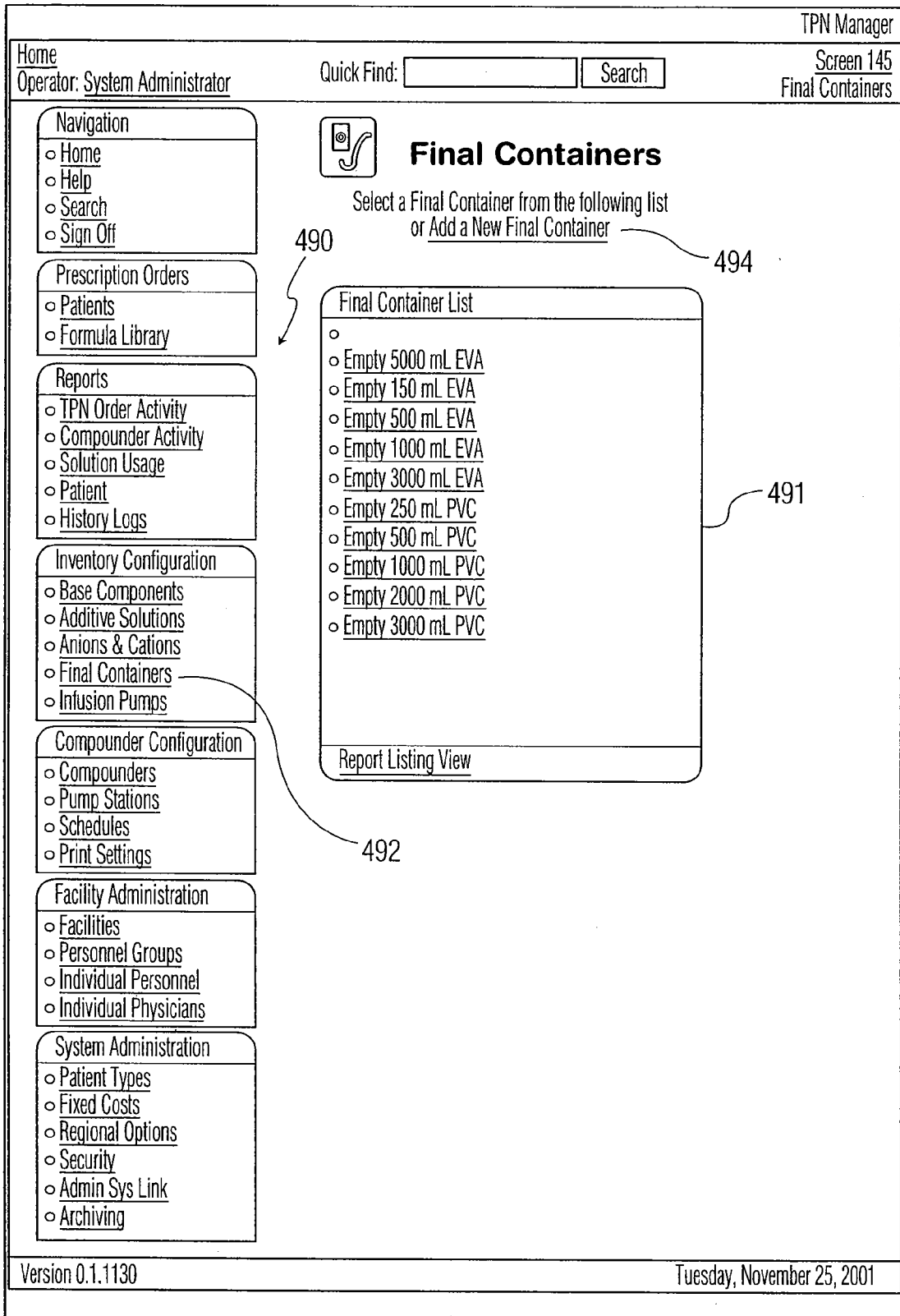

FIG. 11E(5)



TPN Manager

Screen 145
Final Container Inventory

Data Entry

Home Operator: System Administrator

Final Container Inventory

History: Created 11/24/2003

Record Status: Enabled Disabled

Container Description: Empty 3000 mL EVA

Rated Size: mL

Maximum Capacity: mL

Nominal Empty Weight: gm

Max Under Nominal Weight: gm

Max Over Nominal Weight: gm

Unit Cost: \$

Save changes to this Record.

Delete this Record.

Exit without saving changes.

Version 0.1.1130

Tuesday, November 25, 2001

Version 0.1.1130

Tuesday, November 25, 2001

493

FIG. 11E(6)

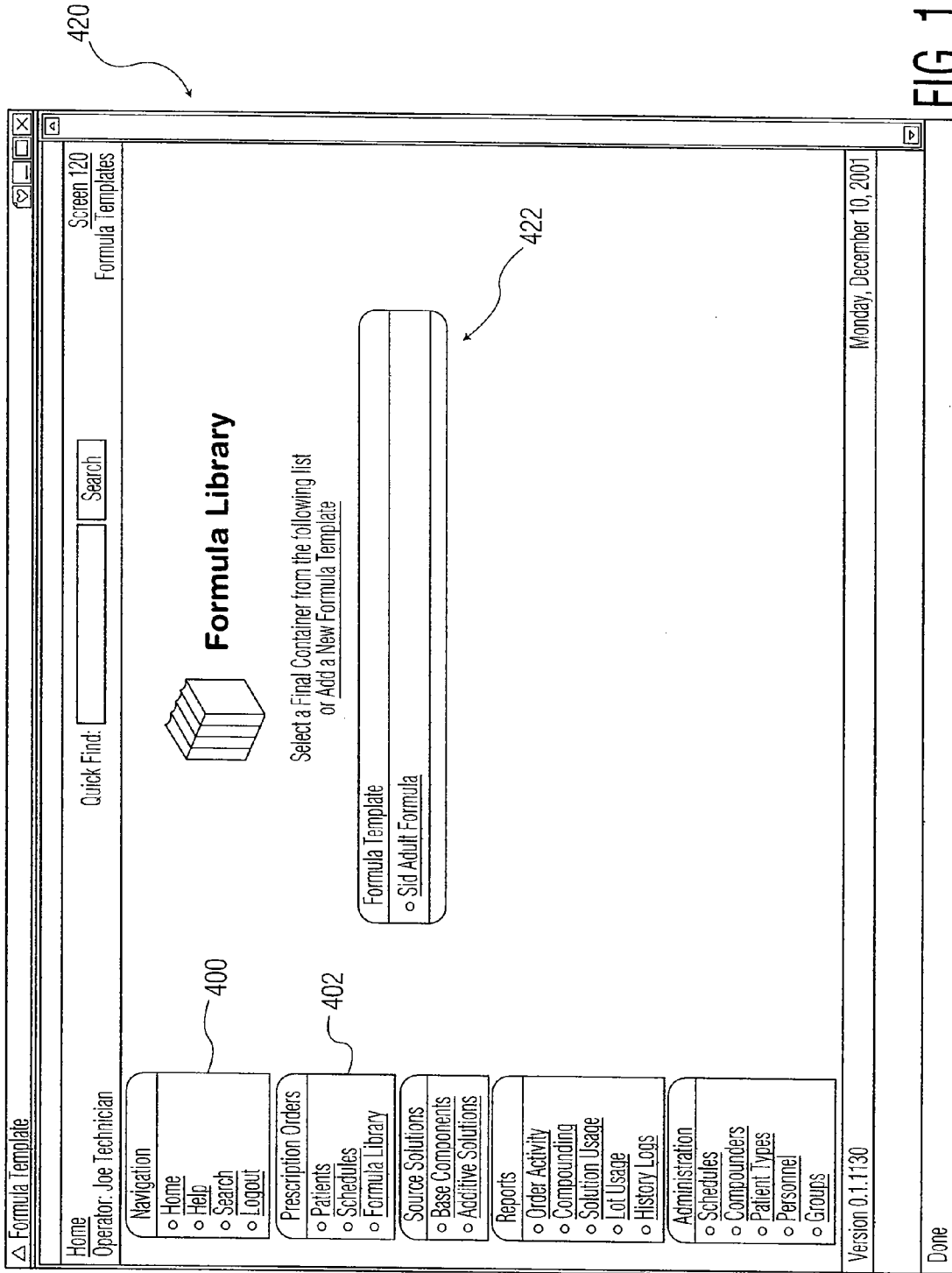



FIG. 11F(1)

434

△ TPN Order Template
Screen 310
TPN Order Template

Home
Data Entry

Operator: Joe Technician



TPN Order Template

Order Formula Template

Formula Template Name:

Formula description and/or special instructions for formula data entry:

Order Number: <input style="width: 80%;" type="text"/>	Order History: <i>(unknown)</i>
Infusion Volume: <input style="width: 80%;" type="text" value="1000"/> mL or <input checked="" type="checkbox"/> Minimum Possible	Infusion Ratio: <input style="width: 80%;" type="text" value="125.00"/> mL / Hour Infusion Period: <input style="width: 80%;" type="text" value="9:20"/> Hours
Overfill Volume: <input style="width: 80%;" type="text" value="0"/> mL	

Container Label Notes:

Worksheet Label Notes:

Done

FIG. 11F(2)

434

△ TPN Order Template
⌵

Base Component	Order Dose	Data Entry Instructions	Edit
Branch Admin	25.00mL /500mL	Instructions	change
Dextrose 70% PF 500mL	0.00 mL		change
Add Solution to Template			
Branched Chain Calculator			
Solution	Order Dose	Per	Submit
<input type="text"/>	<input type="text"/>	<input type="text"/>	
Data Entry Instructions (optional)			
<input type="text"/>			

Additive Solution	Order Dose	Data Entry Instructions	Edit
Sodium Chloride	15.00 mEq /500mL	Instructions	change
Add Solution to Template			
Solution	Order Dose	Per	Submit
<input type="text"/>	<input type="text"/>	<input type="text"/>	
Data Entry Instructions (optional)			
<input type="text"/>			

Nutritional Content Summary 0.12 gm Nitrogen	Electrolyte Content Summary 0 mEq NA +
---	---

Done

FIG. 11F(3)

434

TPN Order Template
Tuesday, December 11, 2001

Additive Solution	Order Dose	Data Entry Instructions	Edit
Sodium Chloride	15.00 mEq /500mL	Instructions	change

Add Solution to Template

Solution

Data Entry Instructions (optional)

Order Dose

Per

<p><u>Nutritional Content Summary</u></p> <p>0.12 gm Nitrogen 4.461 Kcal Protein 1195.000 Kcal Dextrose 0.000 Kcal Lipid 1199.461 Kcal Total</p> <p>Total Volume 543.5 mL</p>	<p><u>Electrolyte Content Summary</u></p> <p>0 mEq NA + 0 mEq K + 0 mEq CA ++ 0 mEq Mg ++ 0 mEq CL - 0 mMol PO4 -- 0 mEq AC -</p> <p>Osmolarity 120.0</p>
---	---

Version 0.1.1130
Done

FIG. 11F(4)

448

The screenshot shows a software window titled "Patient Information" with a menu bar containing "Home", "Operator: Joe Technician", "Data Entry", and "Screen 211 Patient Information". The main area contains a "Patient Information" section with a "History: New Record" label. Below this are several input fields: "Patient ID:" (text box), "Name:" (text box), "Patient Type:" (radio buttons for Adult, Pediatric, Neonate), "Sex:" (radio buttons for Male, Female), "Age:" (text box with radio buttons for Years, Months, Days), "Height:" (text box with radio buttons for Inches, cm), "Weight:" (text box with radio buttons for Lbs, Kg), "Location:" (text box), "Physician:" (text box), "Diagnosis:" (text box), "Allergies:" (text box), and "Notes:" (text box). At the bottom right, there is a section for "Authorized Personnel:" with four checkboxes: "Administrative Staff", "Pharmacy Staff", "Pharmacy Technician", and "Superuser". A "Done" button is located at the bottom right corner of the window.

History: New Record
Patient ID:
Name:
Patient Type: Adult Pediatric Neonate
Sex: Male Female
Age: Years Months Days
Height: Inches cm
Weight: Lbs Kg
Location:
Physician:
Diagnosis:
Allergies:
Notes:
Authorized Personnel:
 Administrative Staff
 Pharmacy Staff
 Pharmacy Technician
 Superuser

Done

FIG. 11G(1)

448

450

△ Patient Information

Age: Years Months Days

Height: 0.0 Inches cm

Weight: 0.0 Lbs Kg

Location:

Physician:

Diagnosis:

Allergies:

Notes:

Authorized Personnel:

- Administrative Staff
- Pharmacy Staff
- Pharmacy Technician
- Superuser

Photo: Photo Not Available Browse

Save changes to this Patient record.

Exit without saving changes.

Version 0.1.1130

Monday, December 10, 2001

Done

FIG. 11G(2)

482

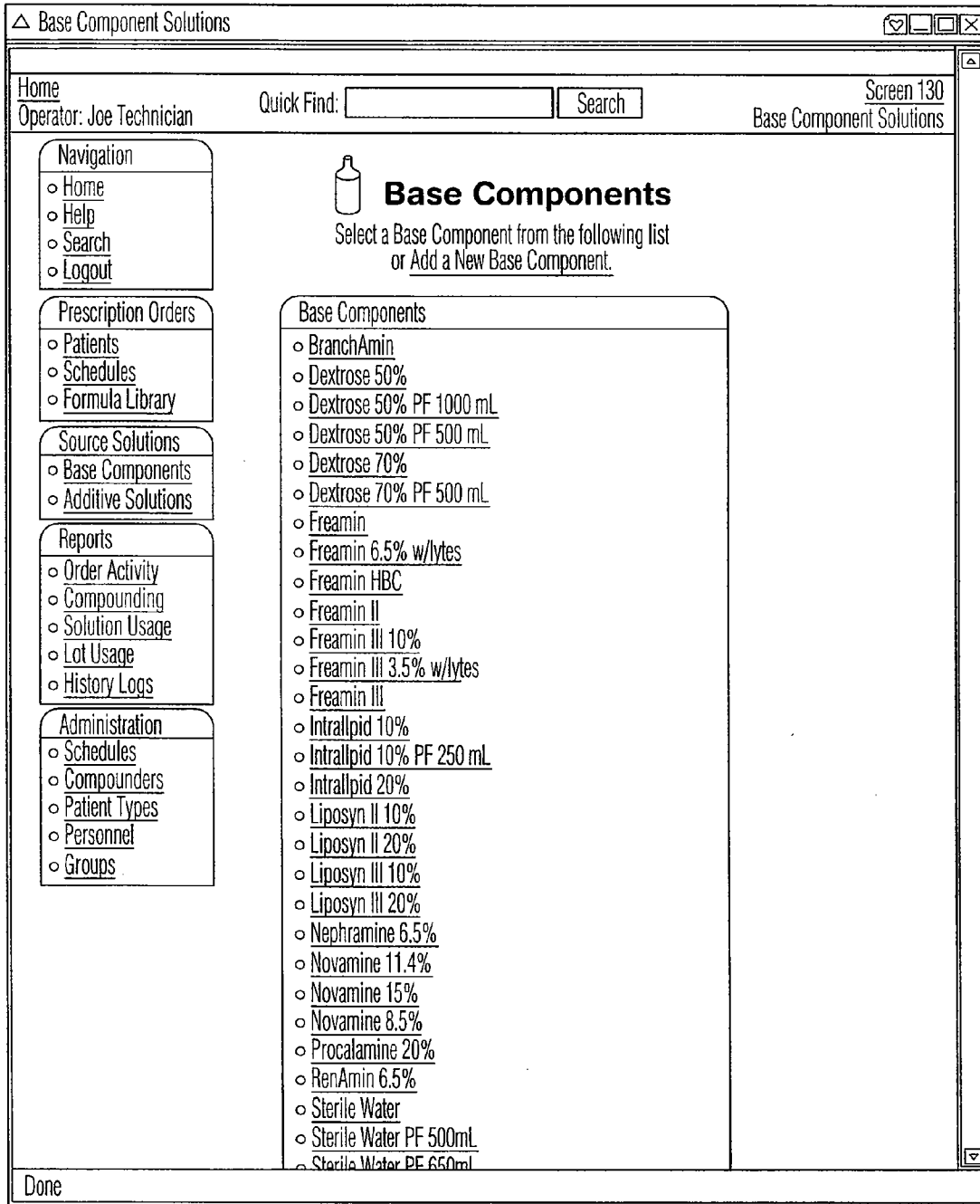
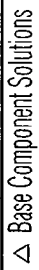



FIG. 11H(1)

484

Base Component Solutions
Screen 130
Base Component Solutions

Home
Data Entry

Operator: Joe Technician

Base Component: Solution Inventory

History: Created 09/26/2001

Record Status: Enabled Disabled

Special Designation: Quiesc

Solution Name:

Print on Label As:

Solution Family:

Concentration:

Specific Gravity:

Cost per 100 mL: \$

Special Container: Pre-Filled Amt: mL Capacity: mL

Special Designation: Branched Chain Amino Acid

Pump Station: 1st Choice:

Notes: 2nd Choice:

3rd Choice:

NDC Numbers:

Electrolyte Content:

Done

FIG. 11H(2)

484

△ Base Component Solutions
x

<p>Electrolyte Content:</p> <table style="width: 100%; border-collapse: collapse;"> <tr><td style="width: 50%;">Na⁺</td><td style="width: 50%; text-align: right;">mmol/mL</td></tr> <tr><td>K⁺</td><td style="text-align: right;">mmol/mL</td></tr> <tr><td>Ca⁺⁺</td><td style="text-align: right;">mmol/mL</td></tr> <tr><td>Mg⁺⁺</td><td style="text-align: right;">mmol/mL</td></tr> <tr><td>PO4⁺</td><td style="text-align: right;">mmol/mL</td></tr> <tr><td>Cl⁻</td><td style="text-align: right;">mmol/mL</td></tr> <tr><td>AC⁻</td><td style="text-align: right;">mmol/mL</td></tr> </table>	Na ⁺	mmol/mL	K ⁺	mmol/mL	Ca ⁺⁺	mmol/mL	Mg ⁺⁺	mmol/mL	PO4 ⁺	mmol/mL	Cl ⁻	mmol/mL	AC ⁻	mmol/mL	<p>Electrolyte Content:</p> <table style="width: 100%; border-collapse: collapse;"> <tr><td style="width: 50%;">Mass Concentration</td><td style="width: 50%; text-align: right;">g/100 mL</td></tr> <tr><td>Nitrogen Content</td><td style="text-align: right;">g/100 mL</td></tr> <tr><td>Protein Calories</td><td style="text-align: right;">Kcal/L</td></tr> <tr><td>Dextrose Calories</td><td style="text-align: right;">Kcal/L</td></tr> <tr><td>Fat Calories</td><td style="text-align: right;">Kcal/L</td></tr> <tr><td>Total BCAA</td><td style="text-align: right;">mg/100 mL</td></tr> <tr><td>Total Non-BCAA</td><td style="text-align: right;">mg/100 mL</td></tr> </table>	Mass Concentration	g/100 mL	Nitrogen Content	g/100 mL	Protein Calories	Kcal/L	Dextrose Calories	Kcal/L	Fat Calories	Kcal/L	Total BCAA	mg/100 mL	Total Non-BCAA	mg/100 mL
Na ⁺	mmol/mL																												
K ⁺	mmol/mL																												
Ca ⁺⁺	mmol/mL																												
Mg ⁺⁺	mmol/mL																												
PO4 ⁺	mmol/mL																												
Cl ⁻	mmol/mL																												
AC ⁻	mmol/mL																												
Mass Concentration	g/100 mL																												
Nitrogen Content	g/100 mL																												
Protein Calories	Kcal/L																												
Dextrose Calories	Kcal/L																												
Fat Calories	Kcal/L																												
Total BCAA	mg/100 mL																												
Total Non-BCAA	mg/100 mL																												

Notes:

Update

Delete

Cancel

Save changes to this Base Component.
Delete this Base Component.
Exit without saving changes.

Version 0.1.1130
Monday, December 10, 2001

Done

FIG. 11H(3)

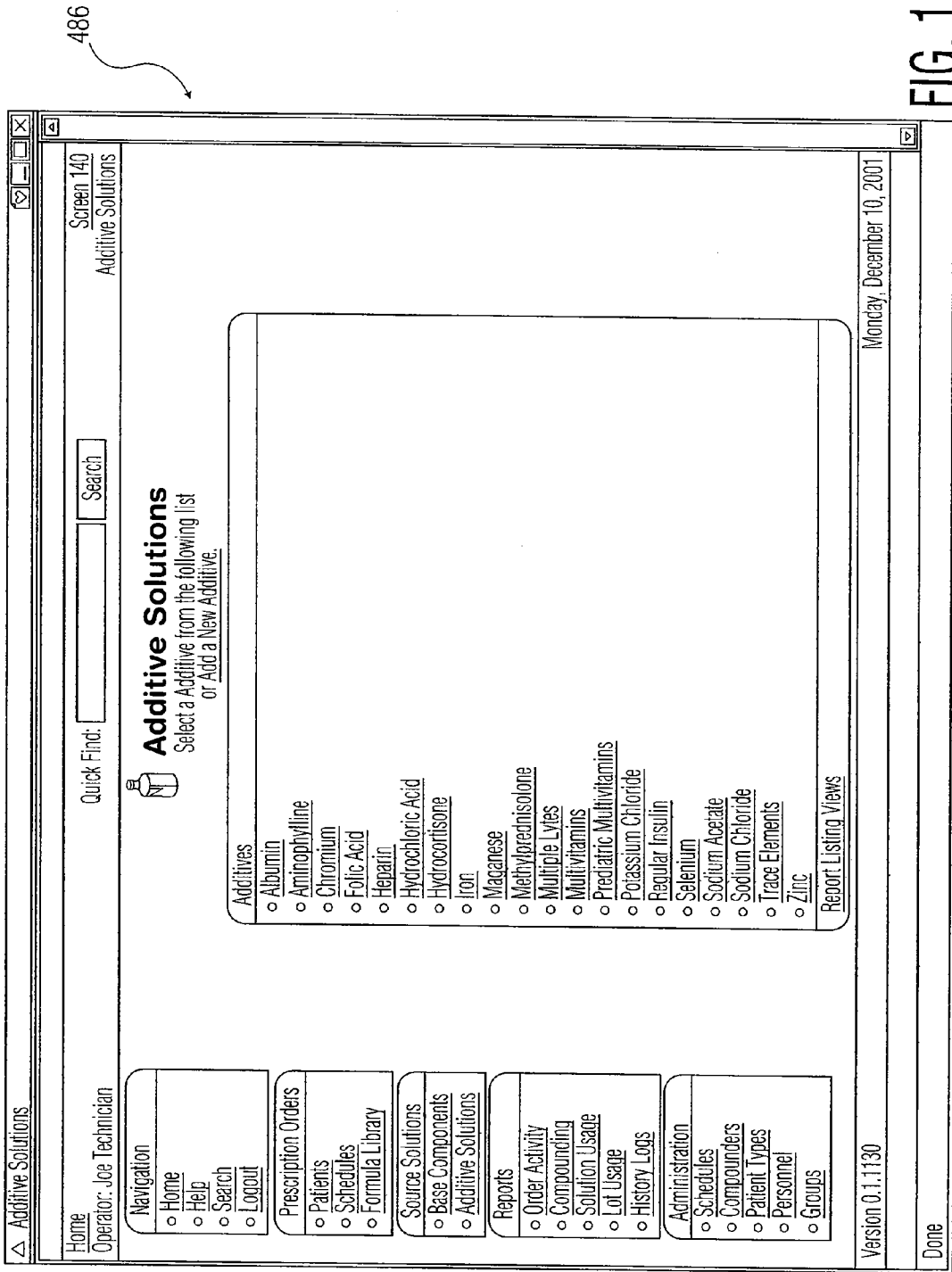

486

FIG. 11I(1)

486

△ Additive Solution Inventory
Screen 141
×

Home
Data Entry
×

Operator: Joe Technician
Additive Solution Inventory
×

Additive Solution Inventory

History: Created 09/09/2001

Record Status: Enabled Disabled

Automatic Selection: Allow Disallow

Solution Name:

Print on Label As:

Use of Patient Type: Adult Pediatric Neonate

Concentration: mEq/mL

Specific Gravity:

Pump Station: 1st Choice:

2nd Choice:

3rd Choice:

NDC Numbers:

Cost per 100 mL: \$

Rinse After Dispensing: Yes No Automatic

Electrolyte Content: Na⁺ mmol/mL

Done

FIG. 11I(2)

486

Additive Solution Inventory
[X] [Min] [Max]

Pump Station: 1st Choice:
 2nd Choice:
 3rd Choice:

NDC Numbers:

Cost per 100 mL: \$

Rinse After Dispensing: Yes No Automatic

Electrolyte Content:

Na ⁺	<input type="text" value="3.00"/>	mmol/mL
K ⁺	<input type="text" value="0.00"/>	mmol/mL
Ca ⁺⁺	<input type="text" value="0.00"/>	mmol/mL
Mg ⁺⁺	<input type="text" value="0.00"/>	mmol/mL
PO ₄ ⁺	<input type="text" value="0.00"/>	mmol/mL
CL ⁻	<input type="text" value="0.00"/>	mmol/mL
AC ⁻	<input type="text" value="1.50"/>	mmol/mL

Notes:

Save changes to this Additive.
 Delete this Additive.
 Exit without saving changes.

Version 0.1.1130 Tuesday, December 11, 2001

Done

FIG. 11I(3)

500 ↘

TPN Manager	
Home	Data Entry
Operator: <u>System Administrator</u>	<u>Screen 162</u> Checklist
 Daily Checklist	
For Compounder: "Cmp-A"	
add a new checklist item	
<u>View checklist reports for this compounder</u>	
Done	Return to Menu.
Copy	Copies this checklist to a different compounder.
Version 0.1.1130	
Tuesday, November 25, 2001	

FIG. 11J(1)

500 ↗

<p>Home Operator: <u>System Administrator</u></p>	<p>Data Entry</p>	<p>TPN Manager <u>Screen 162</u> Prescription Data Entry</p>	
<div style="display: flex; align-items: center; justify-content: center;"> <h2 style="margin: 0;">Daily Checklist</h2> </div>			
<p>For Compounder: "Cmp-A"</p>			
1. Disinfect Laminar Flow Hood Work Surfaces	edit	move up	move down
2. Install New Transfer Set	edit	move up	move down
add a new checklist item			
view checklist reports for this compounder			
<div style="display: flex; justify-content: space-around; margin-top: 10px;"> <input type="button" value="Done"/> <input type="button" value="Copy"/> </div> <p style="margin-top: 5px; text-align: center;">Return to Menu. Copies this checklist to a different compounder.</p>			
<p style="font-size: small; margin-top: 10px;">Version 0.1.1130 Tuesday, November 25, 2001</p>			

FIG. 11J(2)

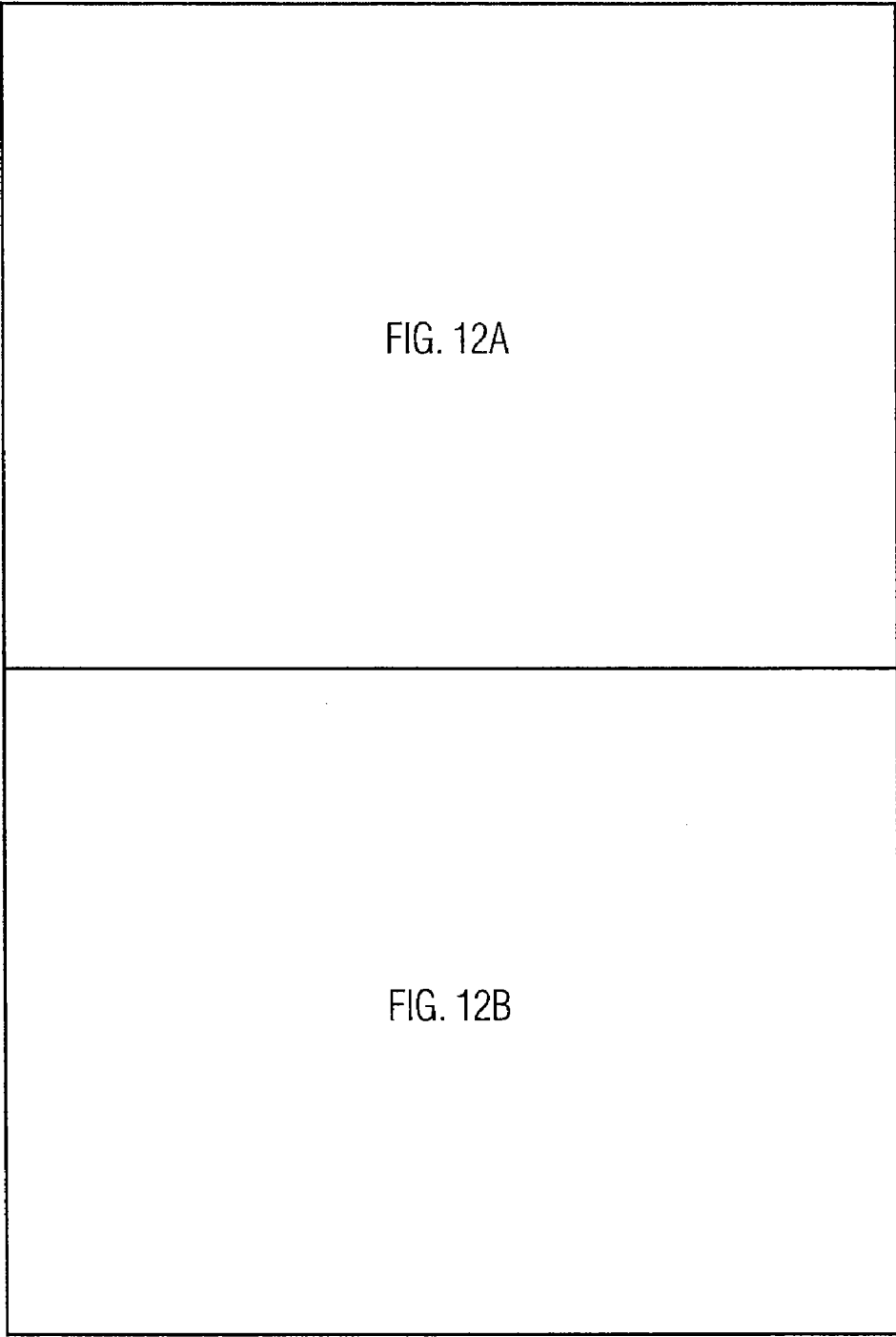

FIG. 12

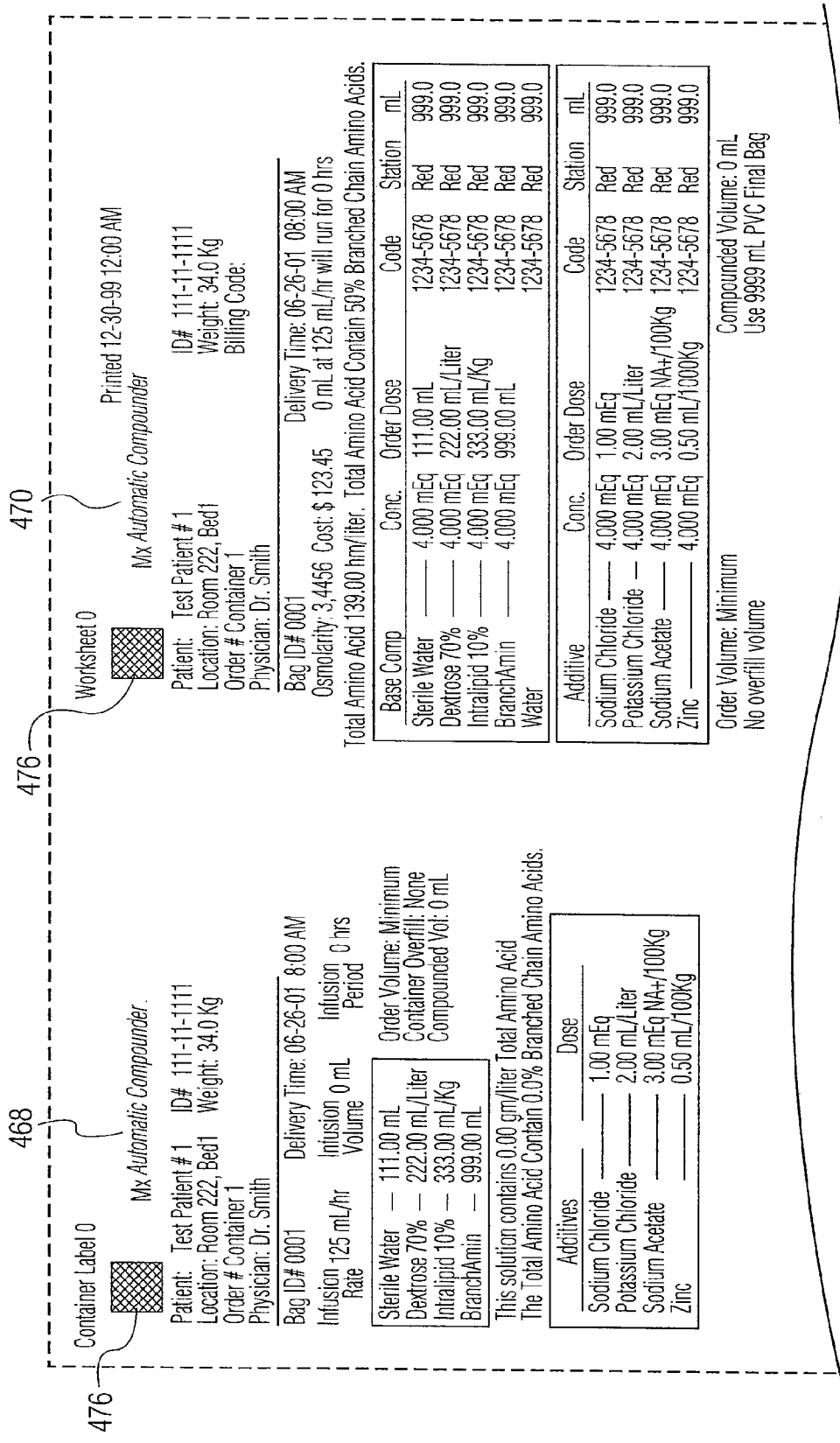

FIG. 12A

Prepared by _____ Unknown

Final Notes: _____ at _____

Expires: Unknown Intended to Use with Piggyback: Intralipid 10%

Piggyback Container Label 0

Mx Automatic Compounder

Patient: Test Patient # 1 ID# 111-11-1111 Weight: 34.0 Kg
 Location: Room 222, Bed1
 Order # Container 1
 Physician: Dr. Smith

Bag ID# 0001 Delivery Time: 06-26-01 08:00 AM

Infusion Rate 125 mL/hr Infusion Volume 0 mL Infusion Period 0 hrs

Piggyback Container

Intralipid 10% — 333.00 mL/Kg

Osmolarity: 3.4567

Electrolytes Contained in Piggyback

NA+	3.02 mEq/liter
Cl-	2.00 mEq/liter
AC-	0.51 mEq/liter

Electrolytes Total

NA+	3.02 mEq/liter
K+	0.00 mEq/liter
CA++	0.00 mEq/liter
MG++	0.00 mEq/liter
PO4-	0.00 mEq/liter
CL-	2.00 mEq/liter
AC-	0.51 mEq/liter

Prepared by _____ Unknown

worksheet notes

Net Contents Wgt: 0.0 gm Estimated Final Container Total Wgt: 9999 gm
 Base Components: 9999 gm Additives: 9999 gm Retractive Index: 0.0000
 Compounded by _____ Manual Adds by _____ Checked by _____
 Nutrition Information 0

Mx Automatic Compounder

Patient: Test Patient # 1 ID# 111-11-1111 Weight: 34.0 Kg
 Location: Room 222, Bed1
 Order # Container 1
 Physician: Dr. Smith

Bag ID# 0001 No Overfill Volume
 Order Volume: Minimum Compounded Vol.: 0 mL

0 mL at 125 mL/hr will run for 0 hrs Osmolarity: 3.4567

This solution contains 0.00 gm/liter Total Amino Acid
 The Total Amino Acid Contain 0.0% Branched Chain Amino Acids.

Nutritional Content	%Total	%NPC
Nitrogen	0.00 gm/liter	
Protein	0.00 Kcal/liter	0%
Dextrose	0.00 Kcal/liter	0%
Lipid	0.00 Kcal/liter	0%
Total	0.00 Kcal/liter	100%
Net Protein	0.00 Kcal/liter	100%

Nutritional Ratios	
Total Kcals /Nitrogen	N/A
Protein Kcals /Nitrogen	N/A
Non-Protein Kcals /Nitrogen	N/A
Protein Kcals / Non-Protein Kcals	N/A
Lipid Kcals / Total Kcals	N/A

FIG. 12B

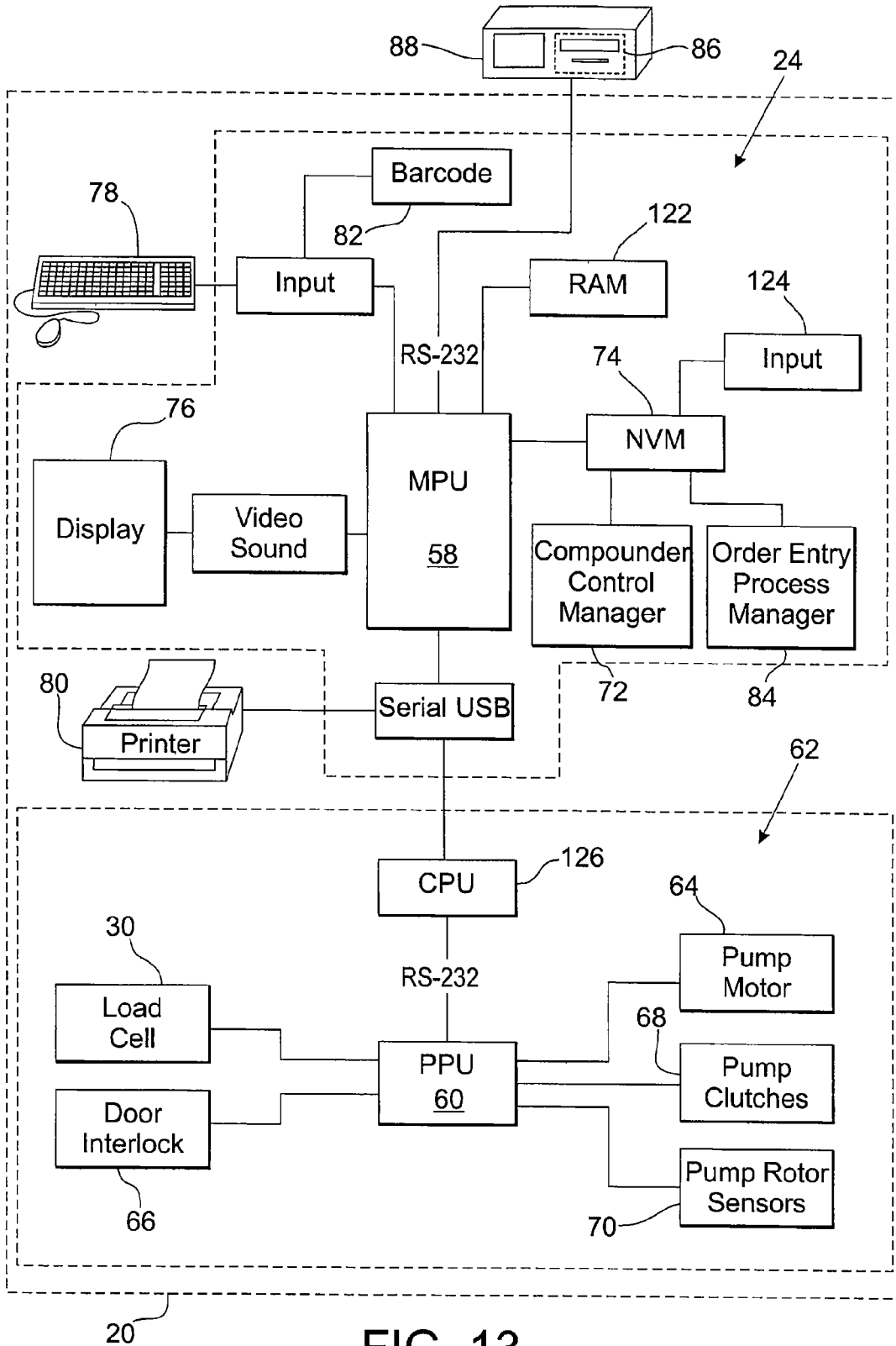

FIG. 13

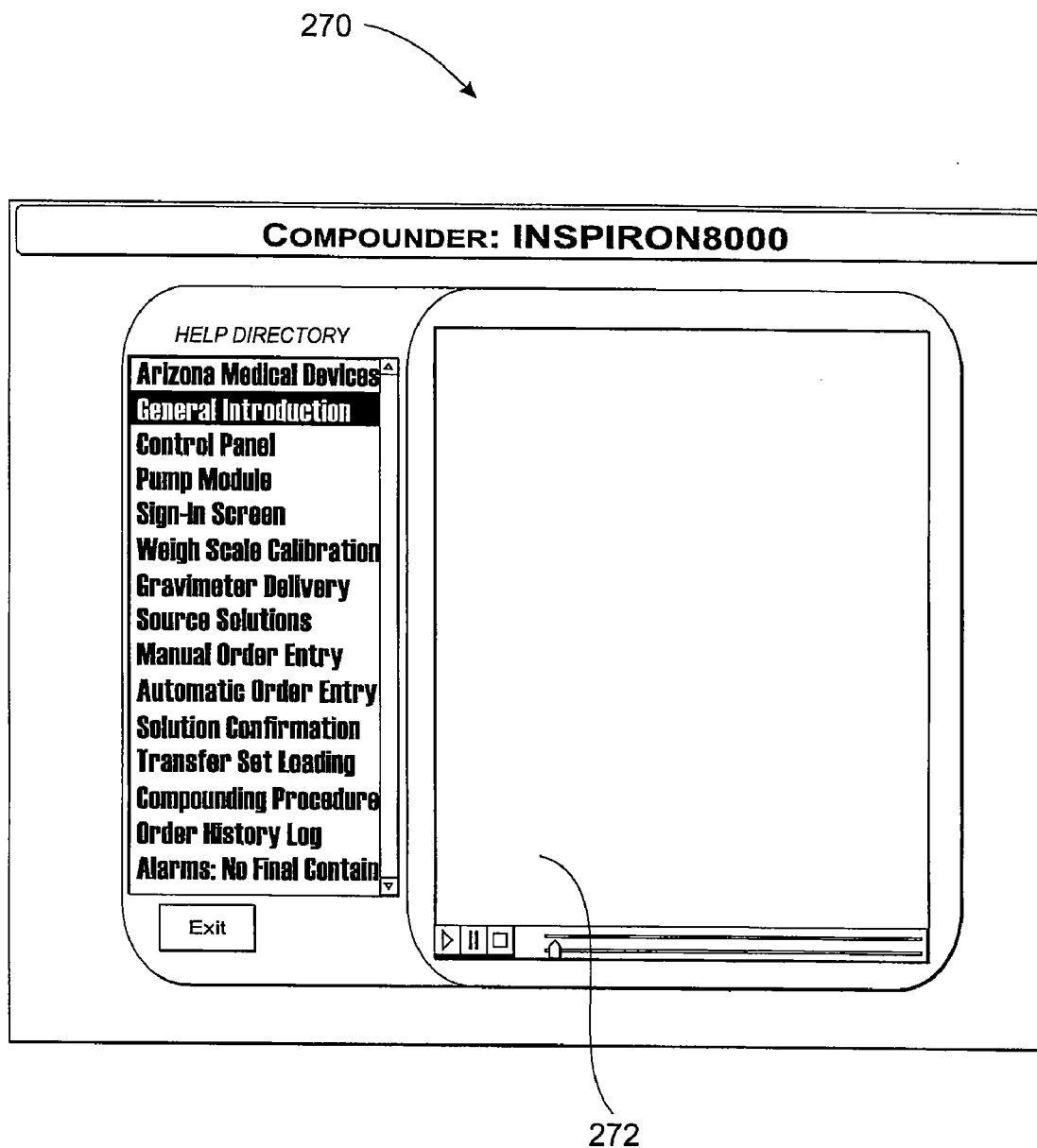

FIG. 14A

272

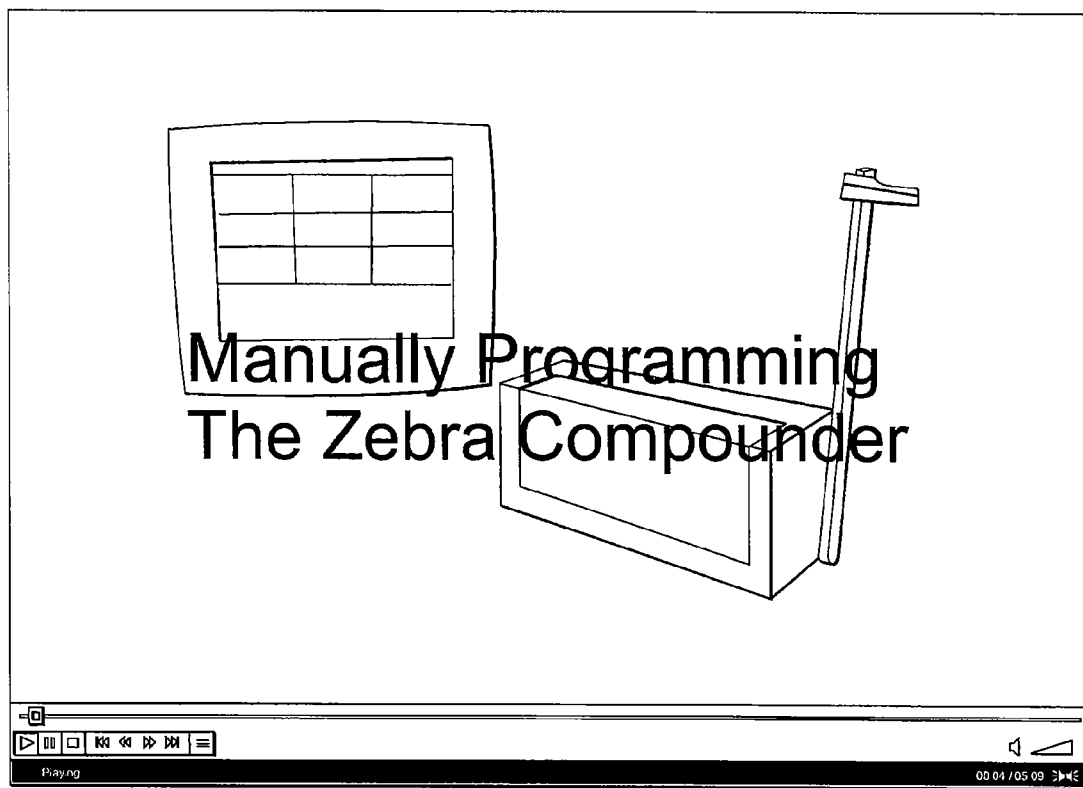

FIG. 14B (1)

272

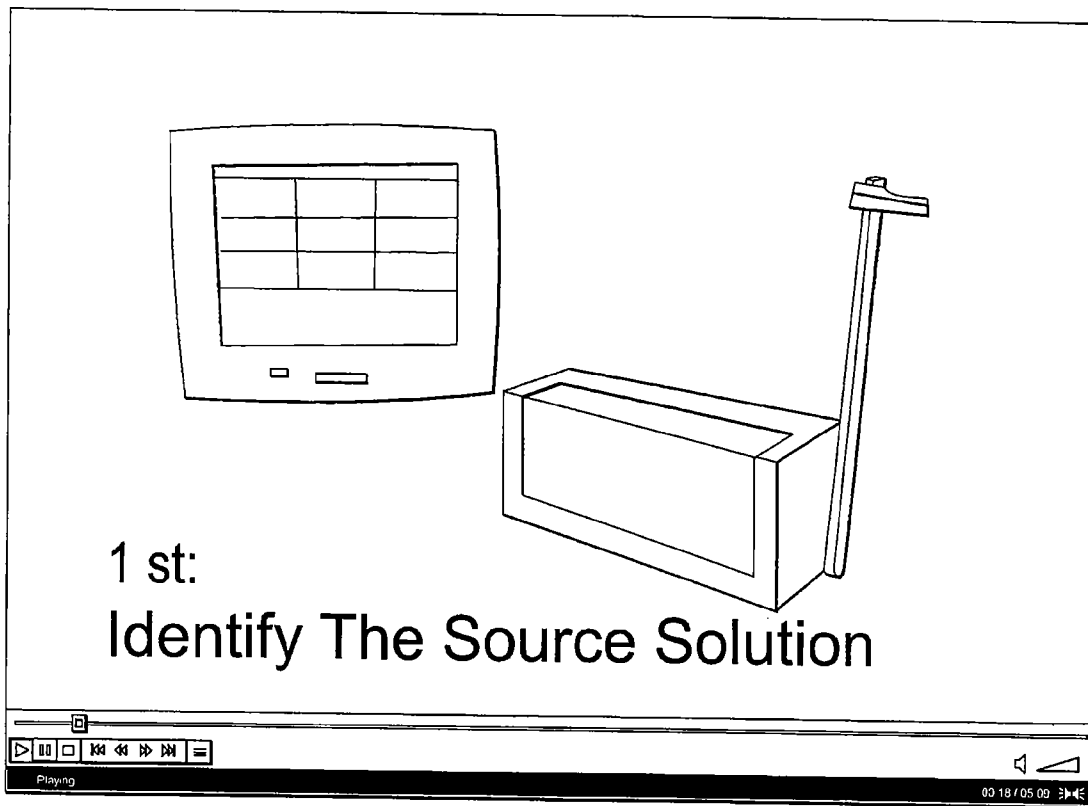

FIG. 14B (2)

272

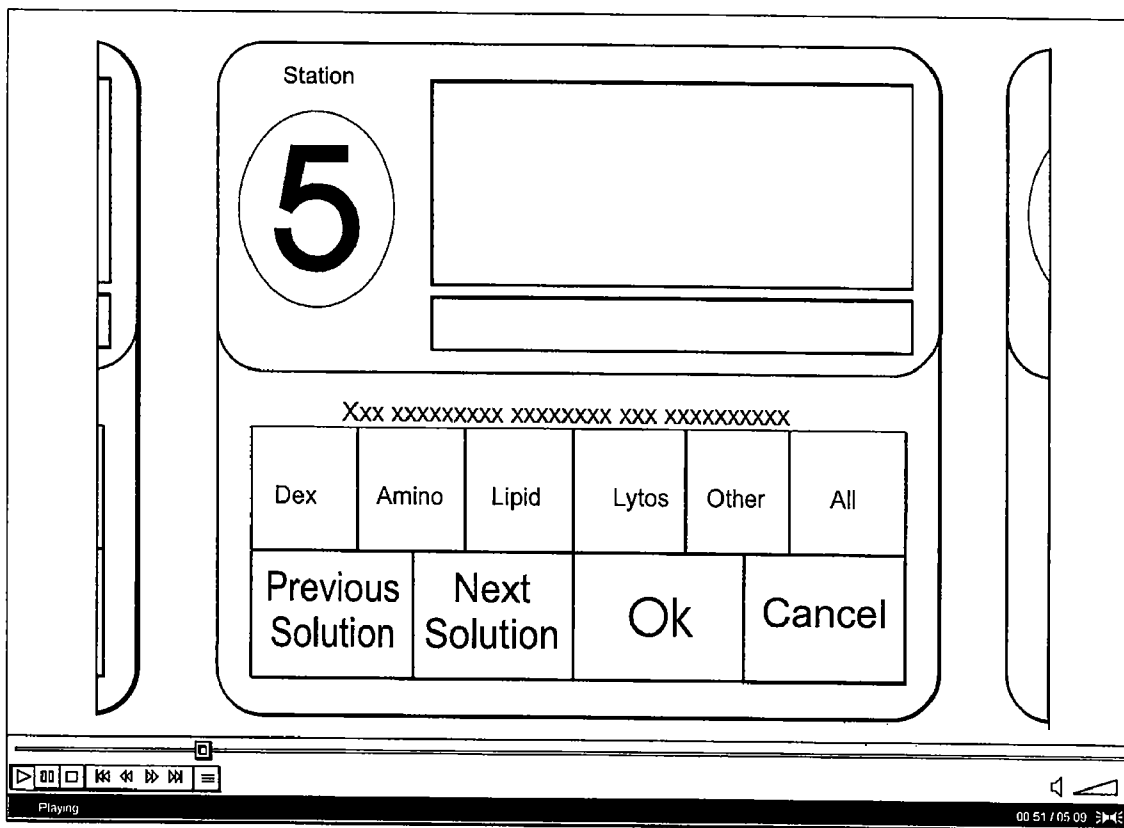

FIG. 14B (3)

272

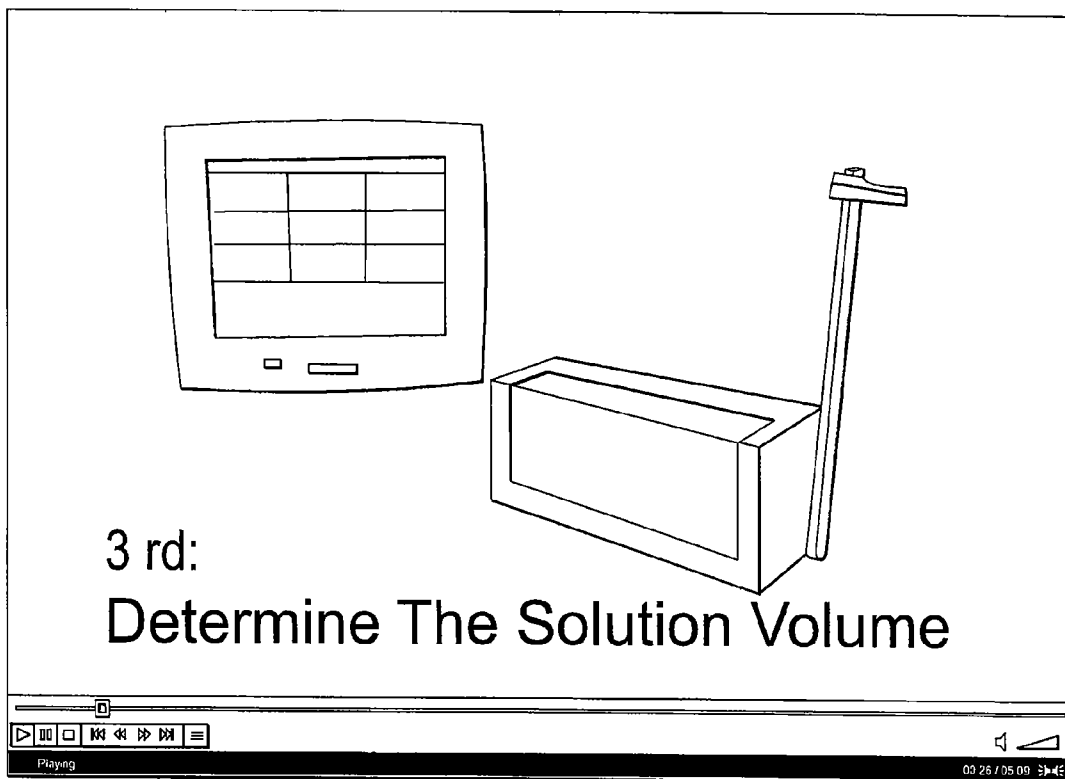

FIG. 14B (4)

272

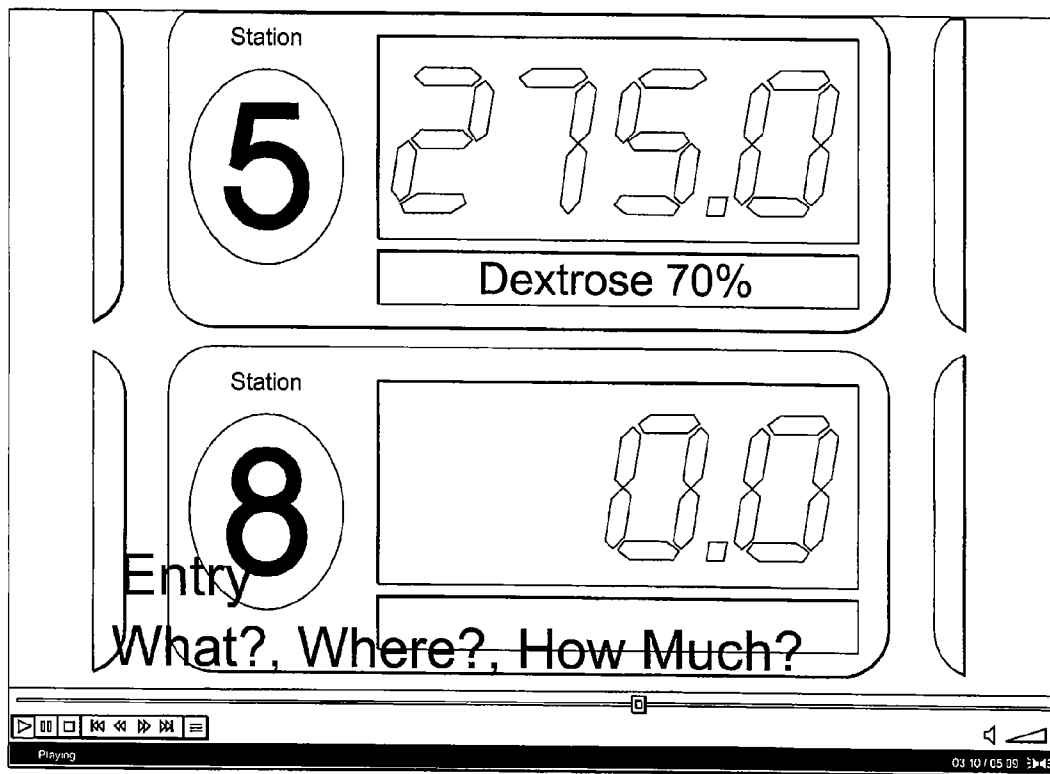

FIG. 14B (5)

272

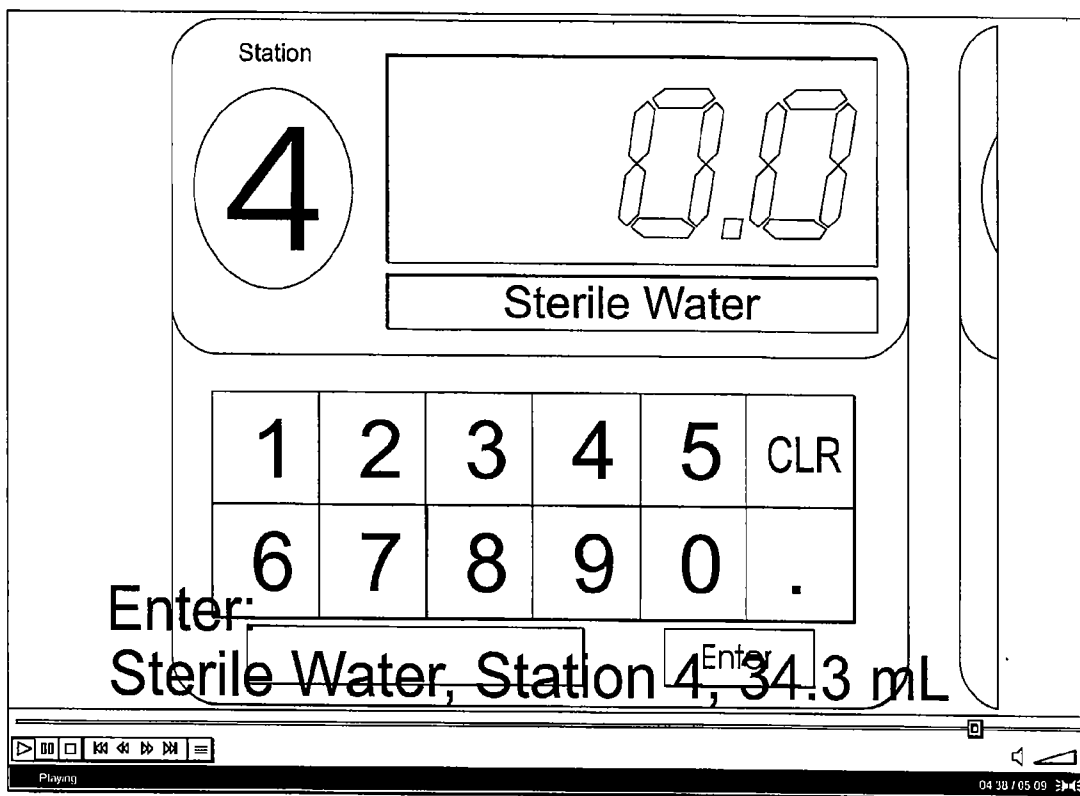

FIG. 14B (6)

272

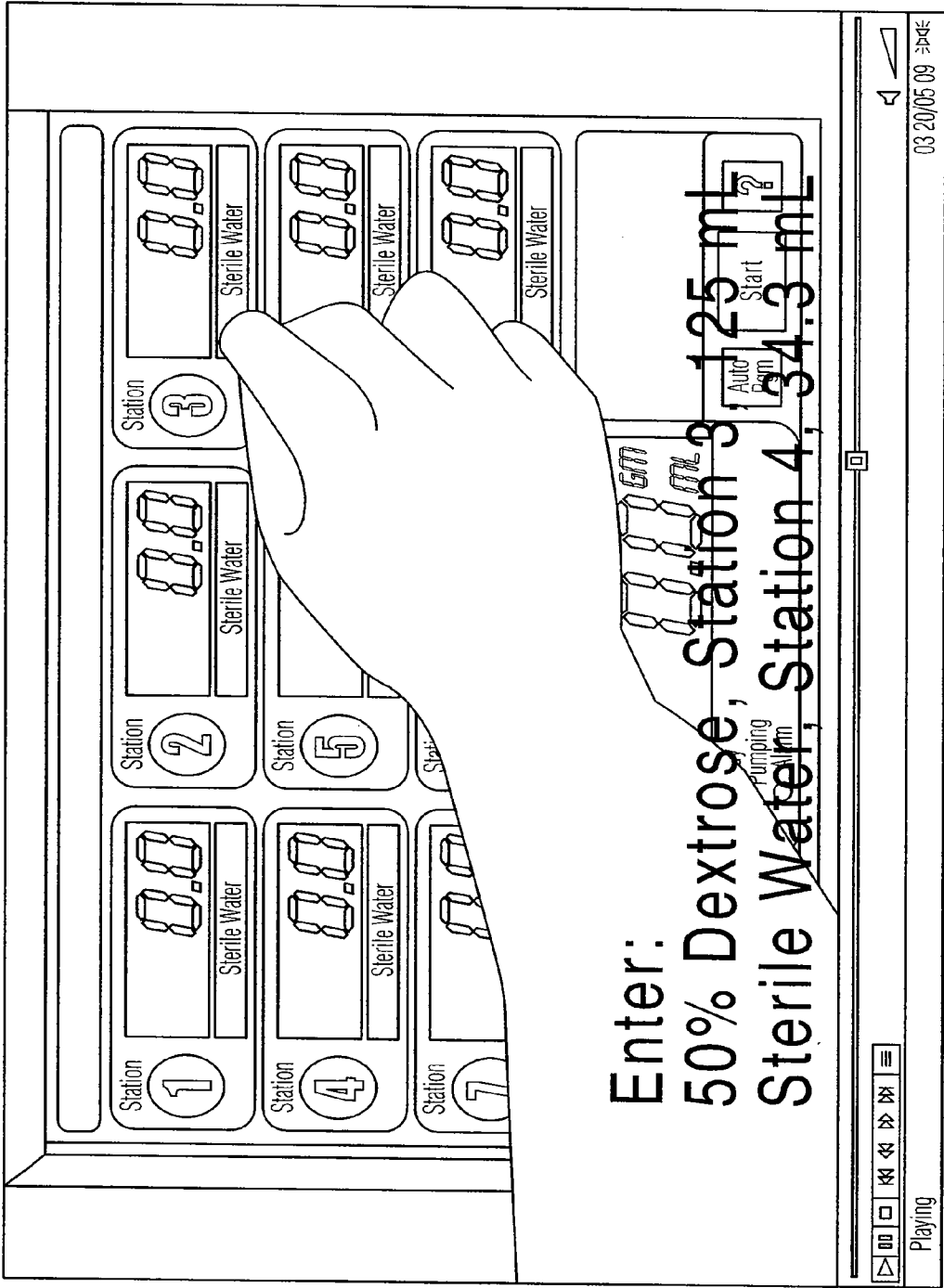

FIG. 14B (7)

272

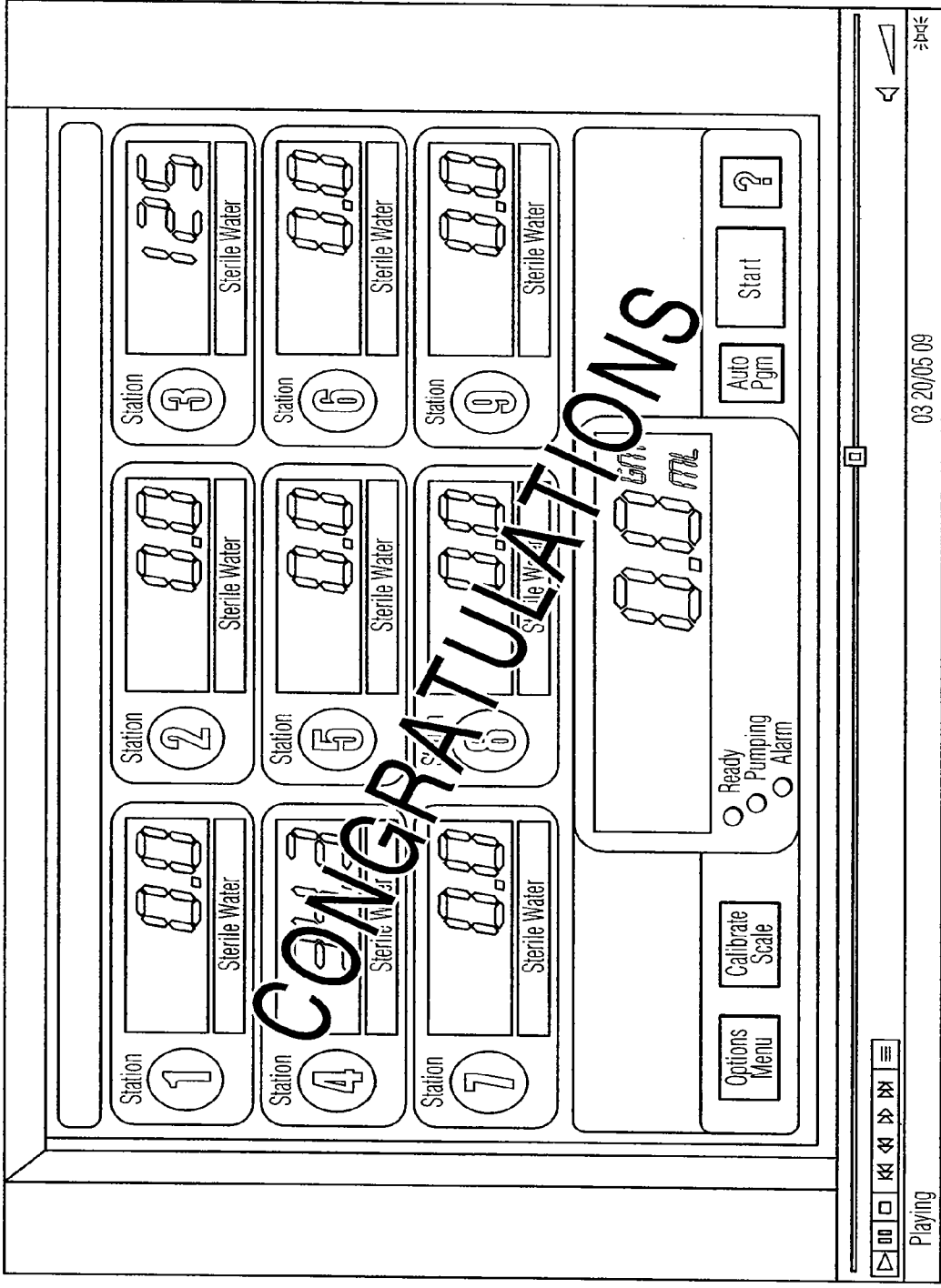

FIG. 14B (8)

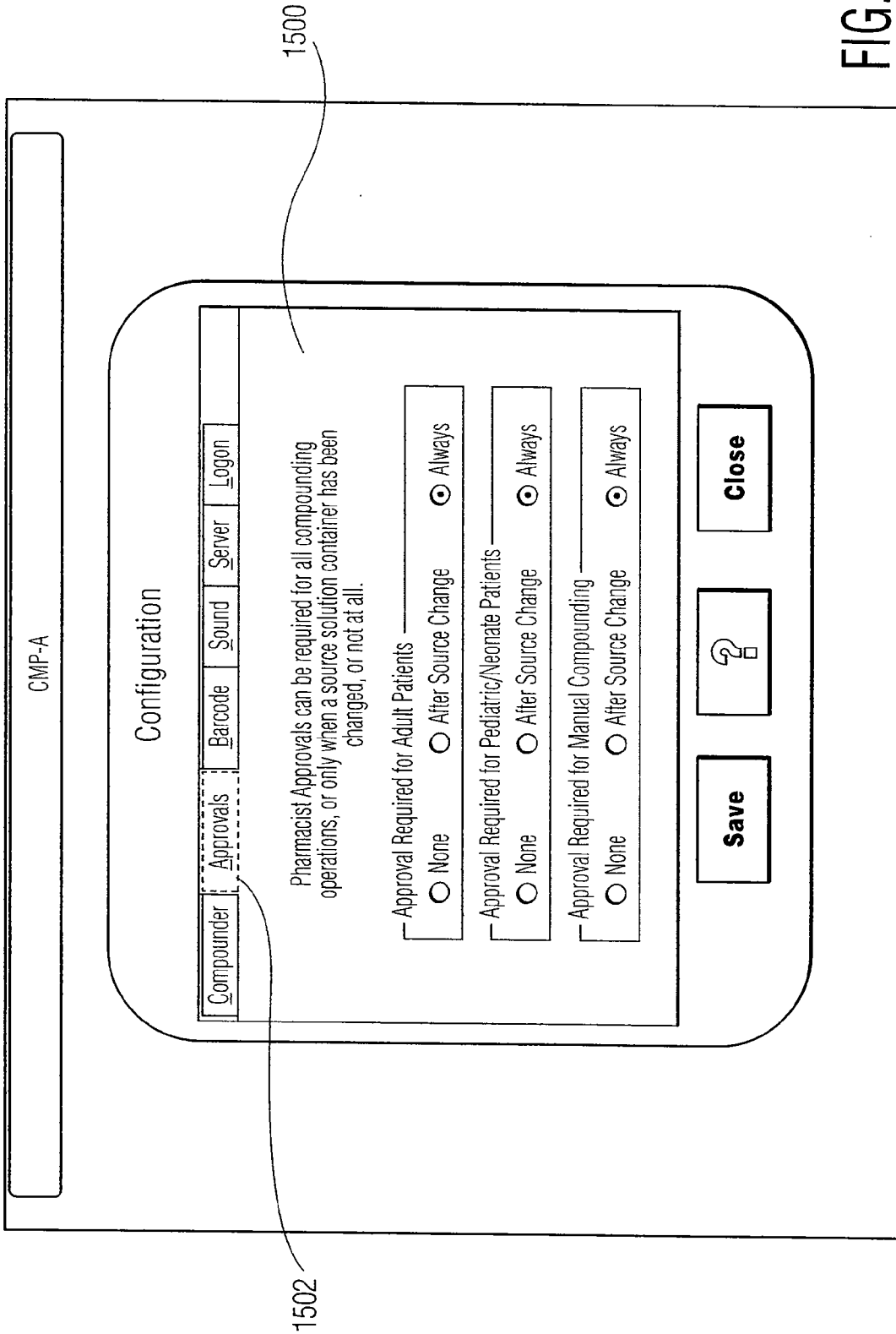

FIG. 15A

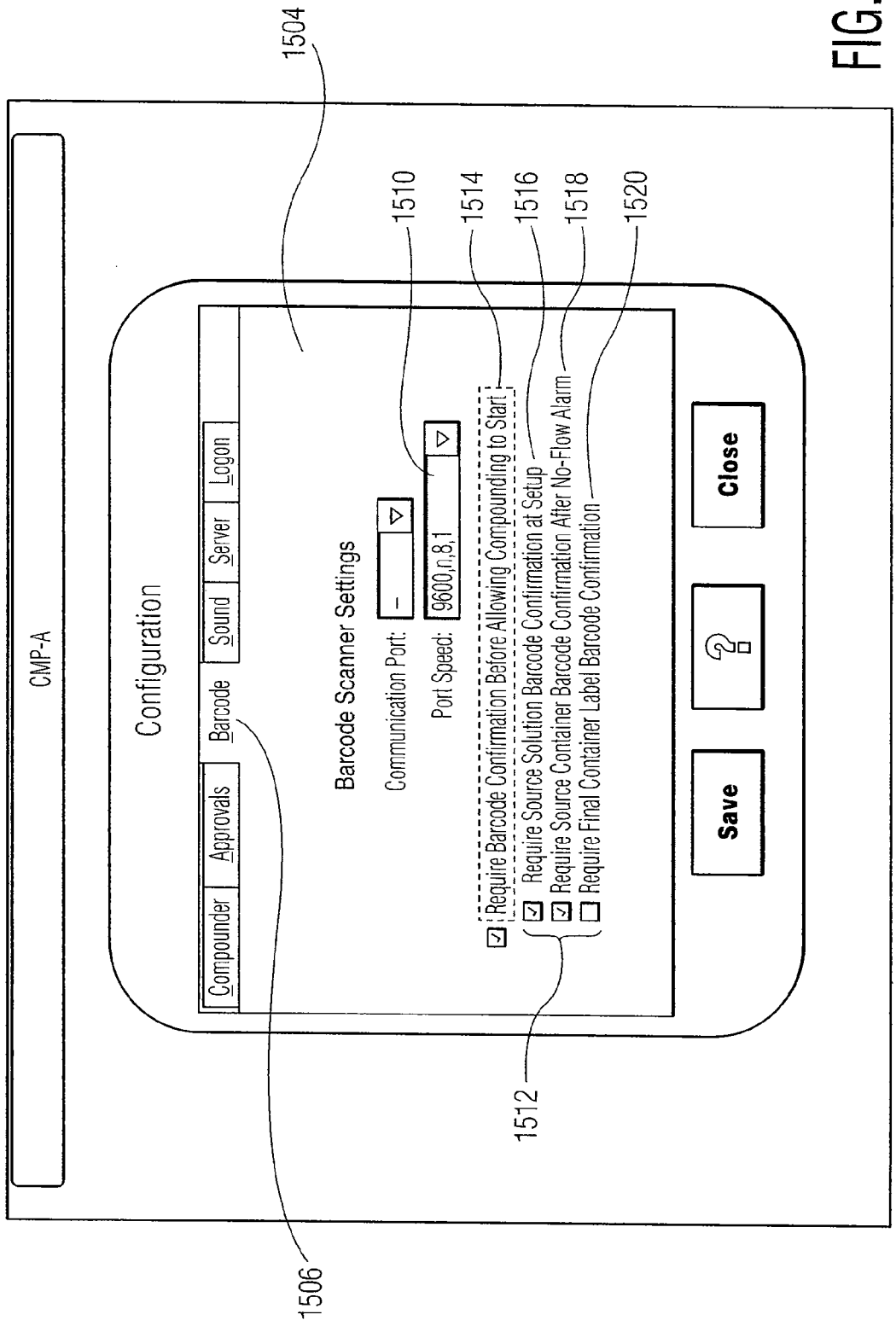

FIG. 15B

Screen is Frozen for Cleaning...

0:26

Press 'ESC' to close this screen immediately

FIG. 16

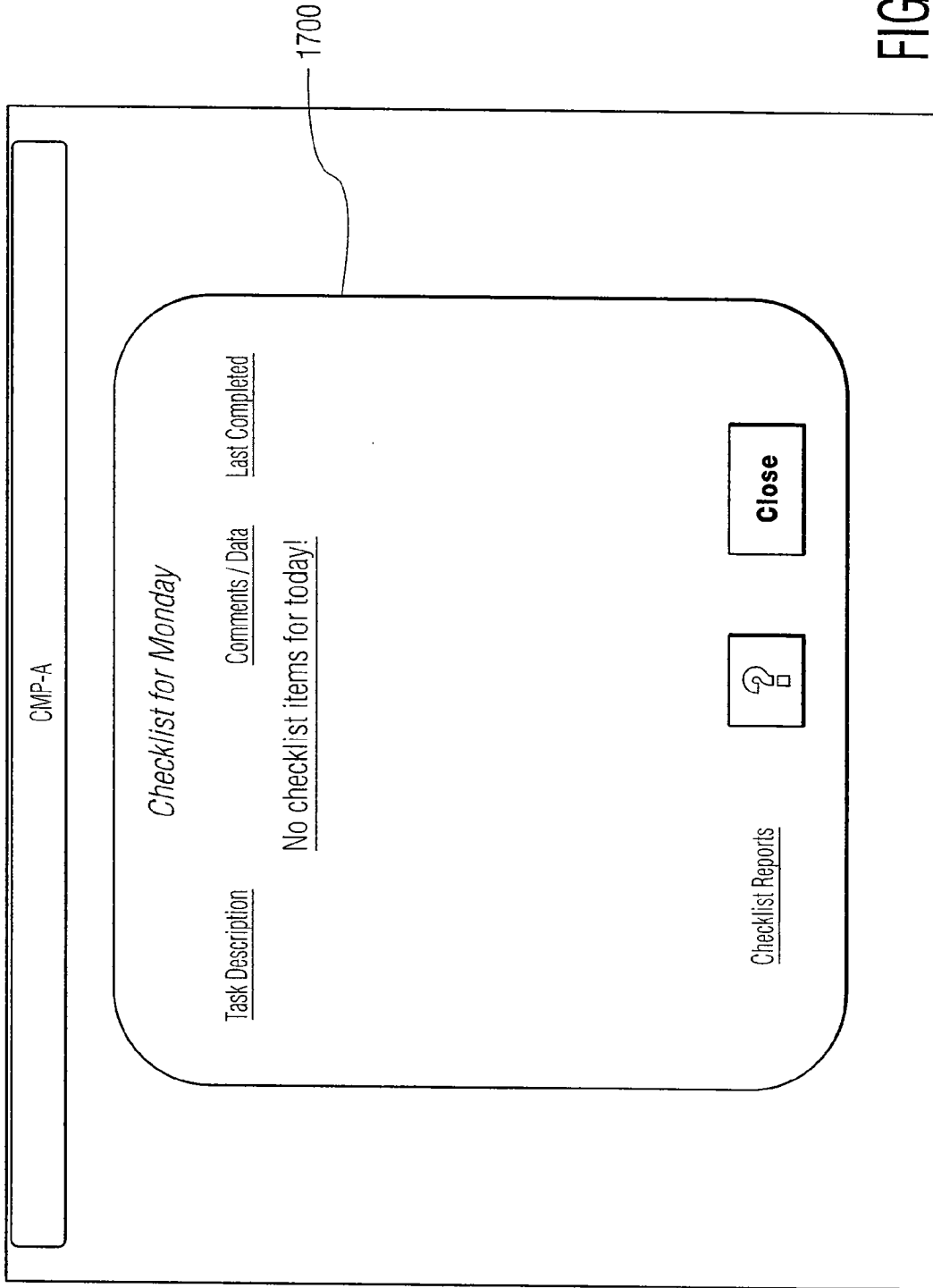

FIG. 17

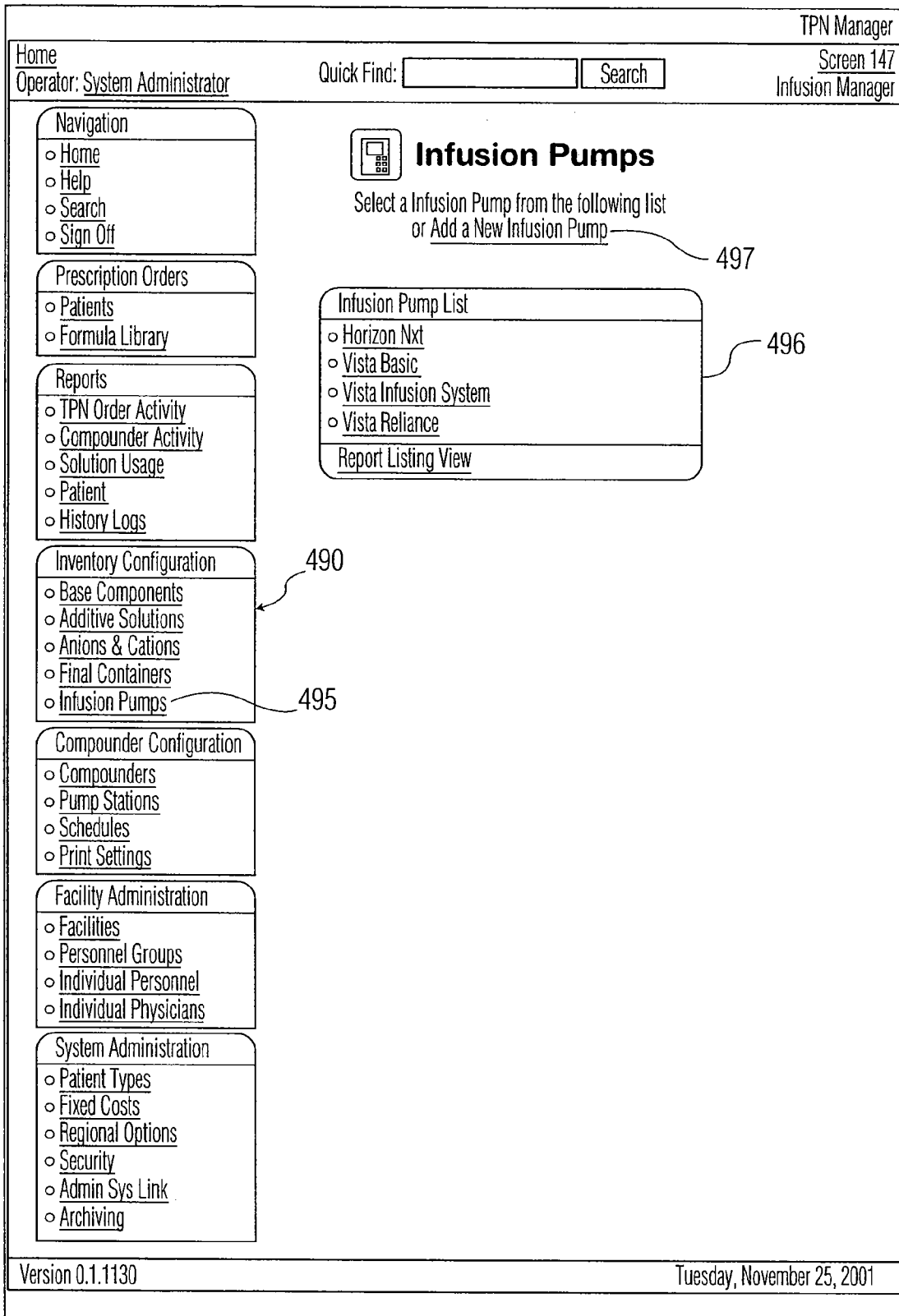

FIG. 18A

TPN Manager

Screen 148

IV Pump Inventory

498

Home

Operator: System Administrator

Data Entry

IV Pump Inventory

History: Created: 11/24/2003

Record Status: Enabled Disabled

IV Pump Model: Horizon Nxt

IV Pump Description: Hospital Pump with barcode reader

Update Save changes to this Record.

Delete Delete this Record.

Cancel Exit without saving changes.

Version 0.0.3971

Tuesday, November 25, 2001

FIG. 18B

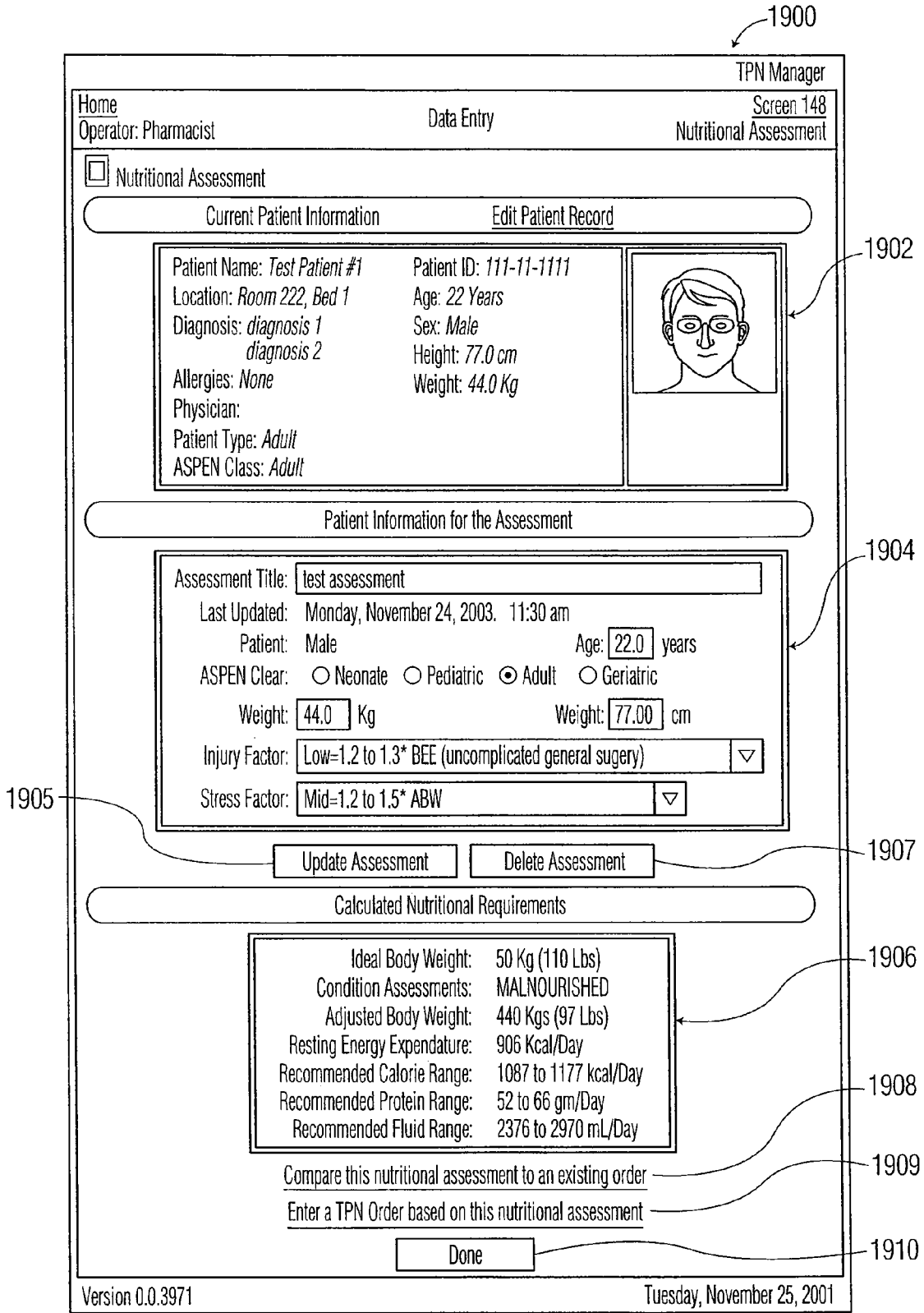

FIG. 19

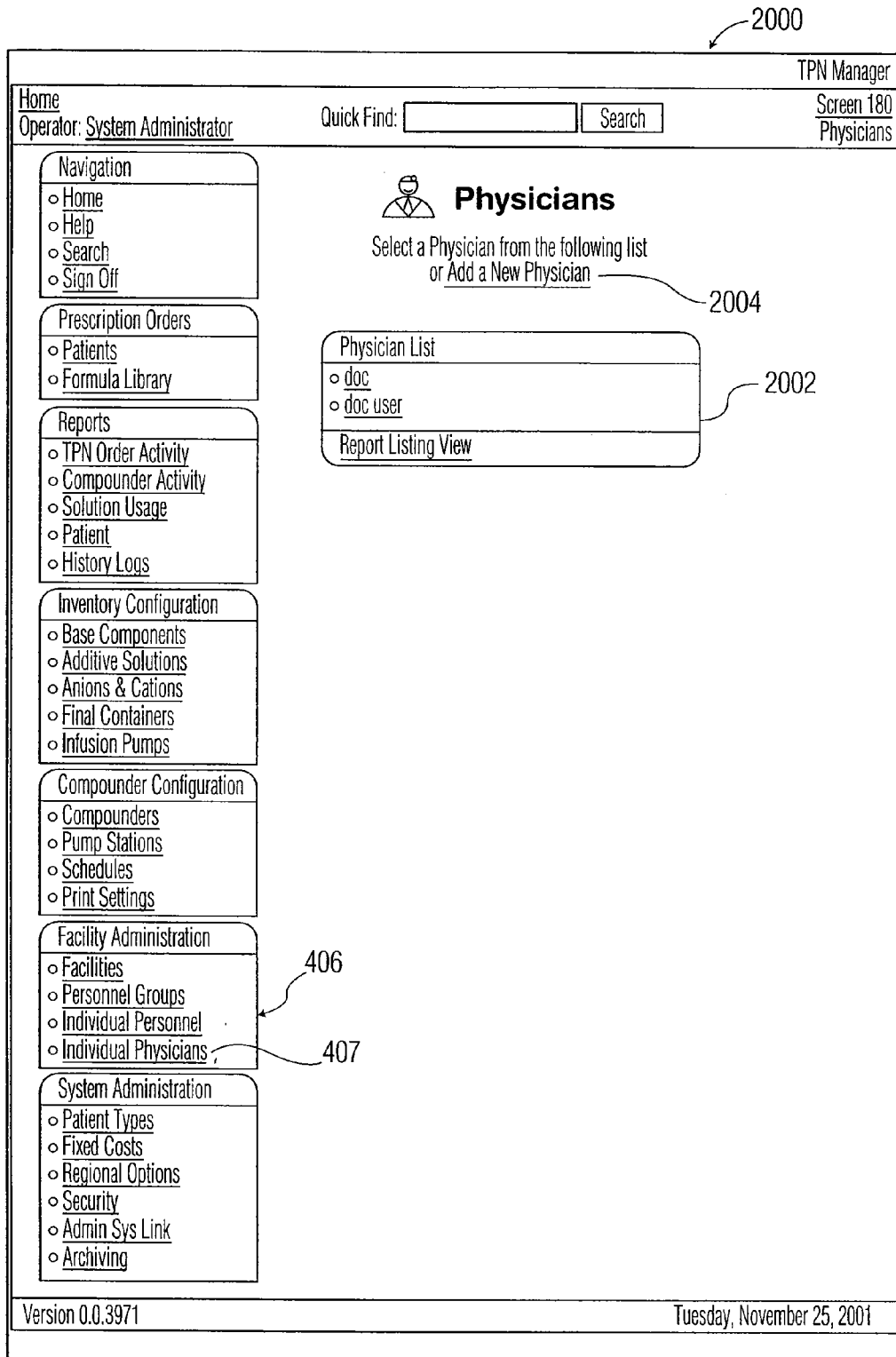
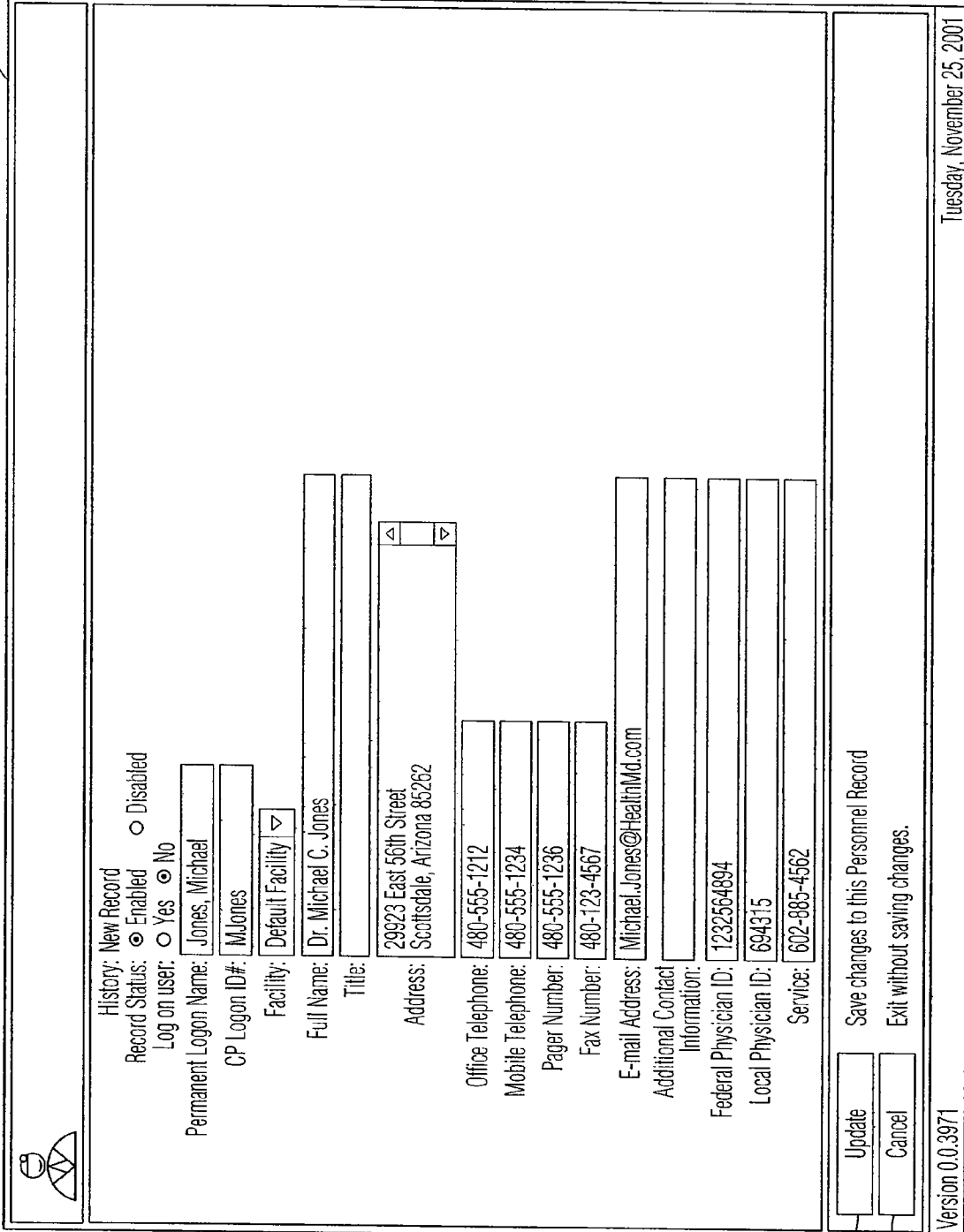

FIG. 20A

2006



History: New Record
 Record Status: Enabled Disabled
 Log on user: Yes No

Permanent Logon Name:
 CP Logon ID#:
 Facility: ▾

Full Name:
 Title:

Address:

Office Telephone:
 Mobile Telephone:
 Pager Number:
 Fax Number:

E-mail Address:
 Additional Contact Information:

Federal Physician ID:
 Local Physician ID:
 Service:

Save changes to this Personnel Record
 Exit without saving changes.

2007

2008

Tuesday, November 25, 2001

Version 0.0.3971

FIG. 20B

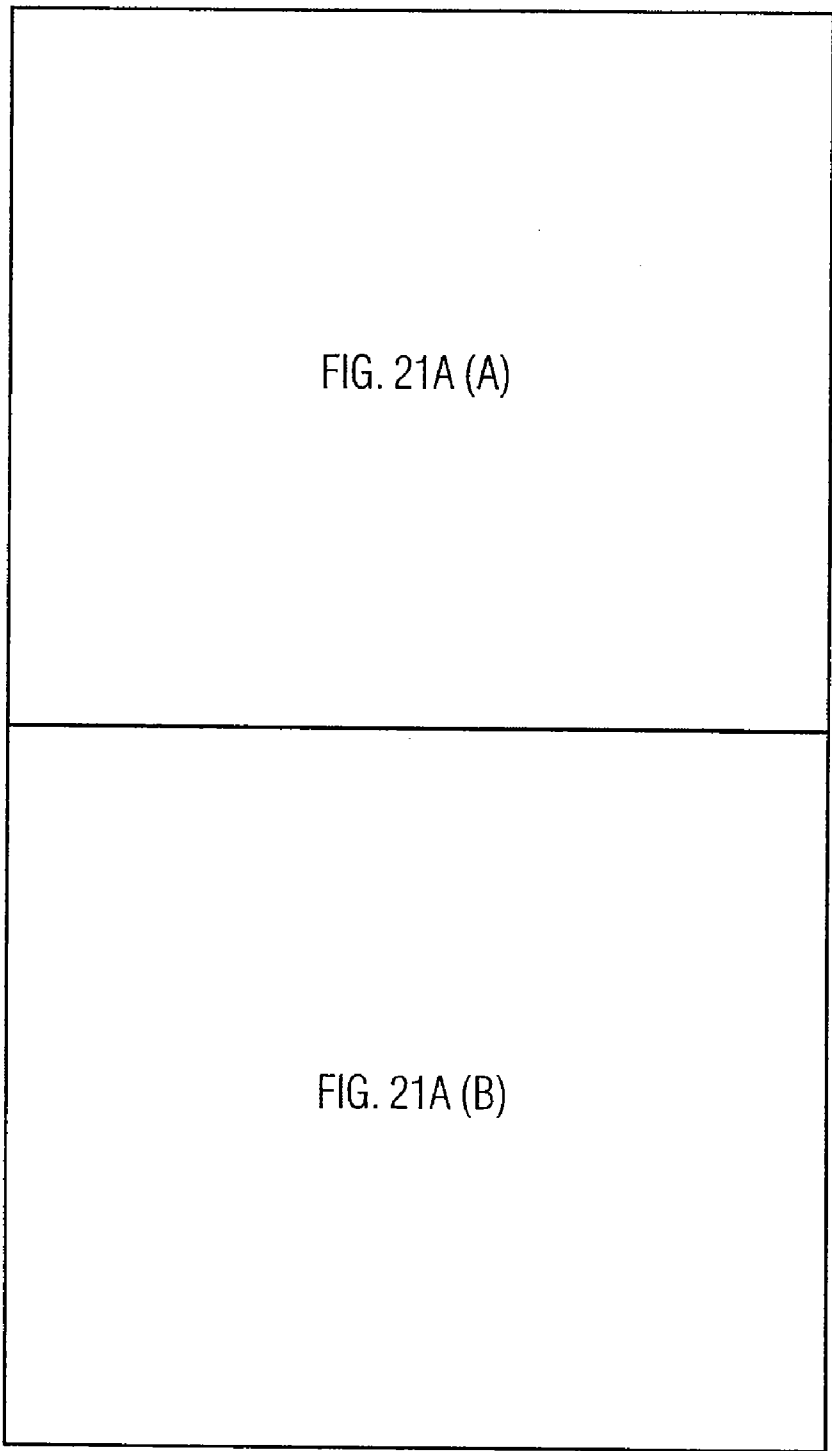

FIG. 21A

2100

TPN Manager

Home Operator: Pharmacist Data Entry Screen 148 TPN Order Entry

TPN Order Entry

Patient Information Edit Patient Record

Patient Name: <i>Test Patient #1</i> Location: <i>Room 1</i> Diagnosis: Physician: Allergies: <i>None</i>	Patient ID: <i>111-11-1111</i> Age: <i>22 Years</i> Sex: <i>Male</i> Height: <i>77.0 cm</i> Weight: <i>44.0 Kg</i>
---	--

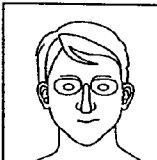

2103

I.V. Container Information

Prescription Order

Order Number: <input type="text" value="TPN1001-TEST"/>	Order History: <i>11/25/2003 19:43:04 (pharm) Changed TPN Order</i>
Billing Code: <input type="text"/>	Batch Copies: <input type="text" value="7"/> Repeating Order: <input type="radio"/> No <input checked="" type="radio"/> Yes
Infusion Volume: <input type="radio"/> Minimum Possible or <input type="text" value="1000"/> mL <input checked="" type="radio"/> Total <input type="radio"/> Per Kg	Infusion Rate: <input type="text" value="125.00"/> mL/Hour Infusion Period: <input type="text" value="0.00"/> Hours
Overfill Volume: <input type="text" value="30"/> mL	Delivery Date: <input type="text" value="11/25/2003"/> Delivery Time: <input type="text" value="12:00 AM"/>
I.V. Pump: <input type="text" value="Horizon Net"/>	Taper: <input type="text"/> Admin Route: <input checked="" type="radio"/> Central <input type="radio"/> Peripheral <input type="radio"/> PICC
Container Label Notes: <input type="text"/>	Worksheet Label Notes: <input type="text"/>

Base Components

Base Component	Order Dose	mL	Edit
FreAmine 10%	<input type="text" value="250.00"/> mL	250.0	detail
Dextrose 70%	<input type="text" value="150.00"/> mL	150.0	detail

2106

Add Solution To Order Branched Chain Calculator

Solution	Order Dose	Per
<input type="text"/>	<input type="text"/> mL	<input type="text"/>

Pre-Fill Container: Piggyback Final Container

2108

FIG. 21A(1)

Additives

Additive Solution	Order Dose	mL	Edit
FreAmine 10%	5.00 mEq	2.00	detail
Dextrose 70%	5.00 mmol	1.70	detail

Add Solution To Order
Additive Assistant Calculator

Solution (default unit)	Order Dose	Per
<input type="text"/>	<input type="text"/> <input checked="" type="radio"/> Default Unit <input type="radio"/> mL	<input type="text"/>

Additive Pooling

Pool Additives: Yes No
 Pool Container Overfill: mL

Nutritional Summary

<u>Order Summary</u>	<u>Nutritional Content</u>	<u>Electrolyte Content</u>
<i>Compounded Volume : 1030.0 mL</i>	<i>4 gm Nitrogen</i>	<i>5 mEq Na+</i>
<i>Osmolarity: 802 mOsm/L</i>	<i>100 Kcal Protein</i>	<i>5 mEq CL-</i>
<i>Aluminum Content: 0 mcg/Kg</i>	<i>358 Kcal Dextrose</i>	<i>7.48 K+</i>
	<i>0 Kcal Lipid</i>	<i>5.1 mmol PO4=</i>
	<i>450 Kcal Total</i>	<i>0 mEq Ca++</i>
		<i>0 mEq Mg++</i>
		<i>0 mEq AC-</i>

Order Status

Open	Submitted	Authorized	Printed	Compounded
Open for Order Entry. <input type="button" value="Submit"/>	Submitted for Review & Authorization.	Review Completed Ready to Print Labels.	Labels Printed, Ready for Compounding.	Order Completed Ready for Delivery to Patient.

Authorize this Order for Compounding.	<input type="checkbox"/> I have reviewed this order for accuracy and compliance with the policies at this facility. Schedule: <input type="text" value="A"/> <input type="text"/> Authorizing Pharmacist: pharm Tuesday, November 25, 2003 <input type="button" value="Authorize for Compounding"/> <input type="button" value="Start Order"/>
---------------------------------------	---

[Delete this TPN Order](#)
[Copy this TPN Order to a New Order](#)
[Copy this TPN Order to the Formula Library](#)

Version 0.0.3971
Tuesday, November 25, 2001

FIG. 21A(2)

TPN Manager
Screen 141
Additive Solution Inventory

Home
Data Entry
Operator: Joe Technician

Additive Solution Inventory

History: Created 11/24/2003

Record Status: Enabled Disabled

Solution Name:

Print on Label As:

Solution Type: Electrolyte Vitamins Trace Minerals Medication Other

Additive Pooling: Allow Disallow

Print Option: List Individually Electrolyte Summary

Concentration:

Specific Gravity:

Osmolarity: mOsm/L

Aluminum Content: mcg/L

Patient Type(s):

- Adult
- Neonate
- Pediatric

Product NDC Numbers:

Cost per mL: \$

Electrolyte Content:

Na+(mEq/ml)	<input type="button" value="v"/>	<input type="text" value="4.0000"/>
CL-(mEq/ml)	<input type="button" value="v"/>	<input type="text" value="4.0000"/>
K+(/ml)	<input type="button" value="v"/>	<input type="text"/>
Ca++(mEq/ml)	<input type="button" value="v"/>	<input type="text"/>
Mg++(mEq/ml)	<input type="button" value="v"/>	<input type="text"/>
PO4-(mEq/ml)	<input type="button" value="v"/>	<input type="text"/>
AC-(mEq/ml)	<input type="button" value="v"/>	<input type="text"/>

Notes:

Update	Save changes to this Additive.
Delete	Delete this Additive.
Cancel	Exit without saving changes.

2120

2122

Version 0.0.3971 Tuesday, November 25, 2001

FIG. 21B

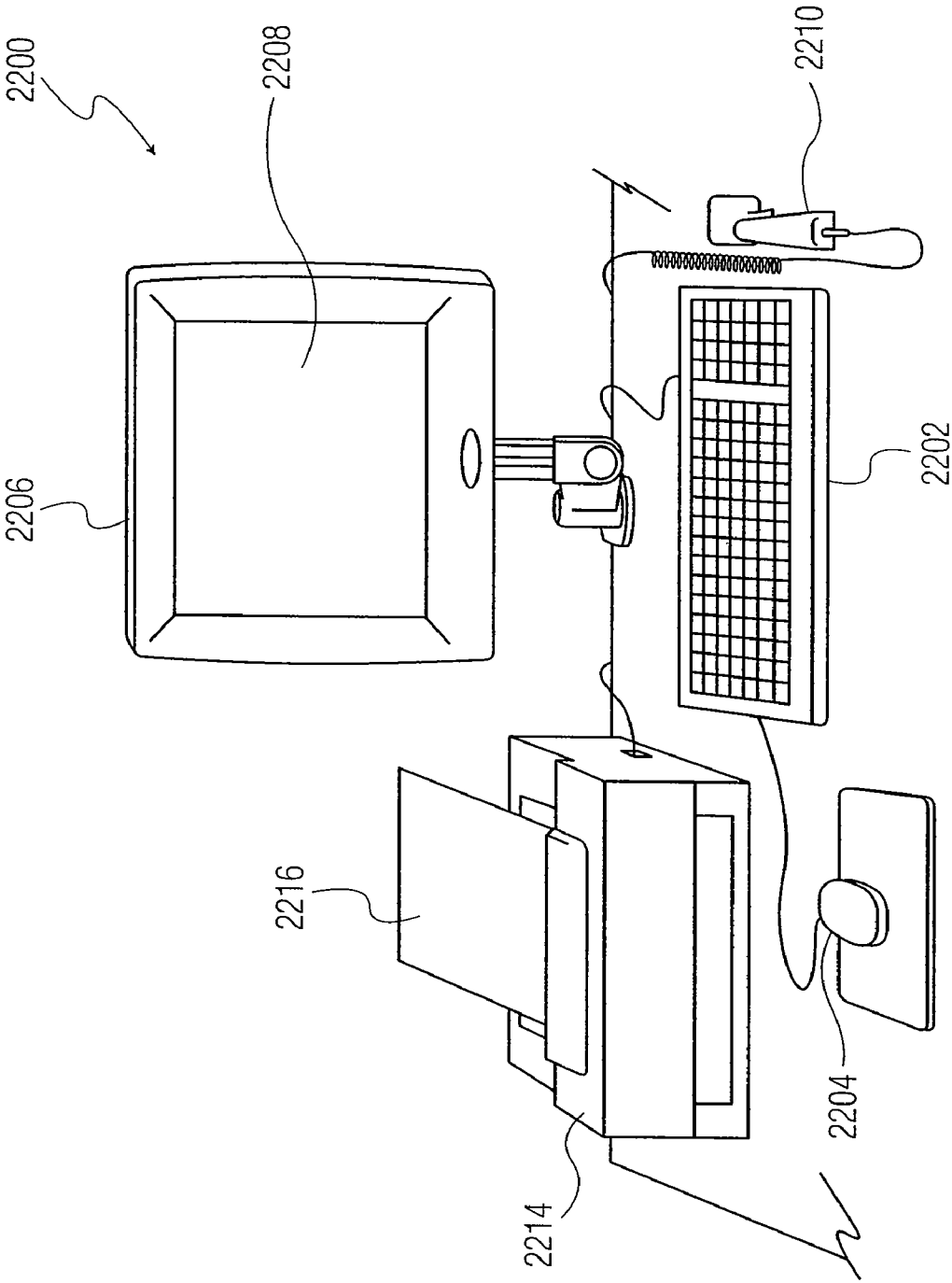
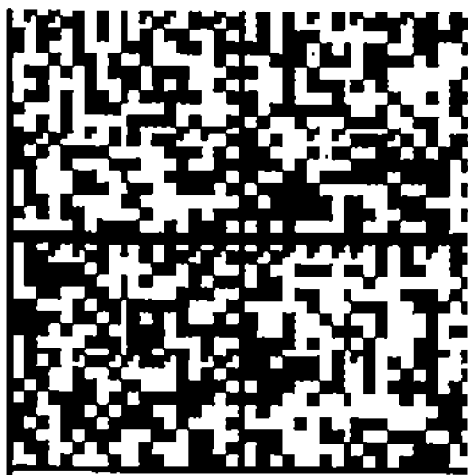
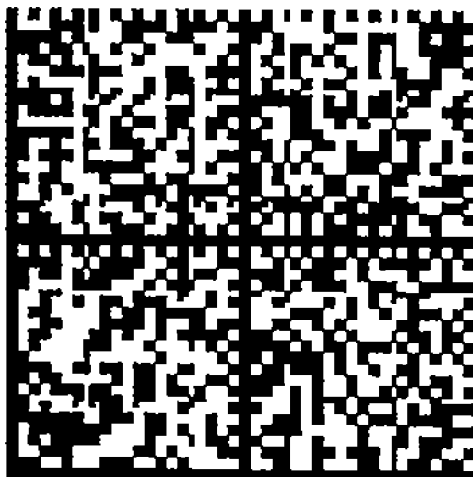

FIG. 22



2300

FIG. 23A



2300

FIG. 23B

2400

6/21/2004 6:00:25

Compounding Summary

Order ID: Manual Order #11 2402
 Operator: Pharm 2404
 Start Time: 6/21/04 8:24:52 PM 2406
 Job Time: 0 Minutes, 09 Seconds 2408
 Job Status: Completed Successfully 2410

Solution Name	Stn	Dose (mL)	Act. (mL)	Accuracy	NDC Number	Lot Number	Expiration
Sterile Water	1	10.5	10.7	64.1	2412		

2414

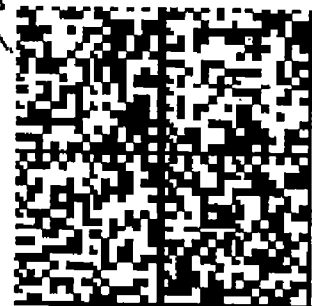

FIG. 24

METHOD FOR TRANSFERRING DATA TO A PHARMACEUTICAL COMPOUNDING SYSTEM

[0001] This application is a Continuation of U.S. patent application Ser. No. 11/003,232 filed on Dec. 3, 2004, which is a Continuation-in-Part of U.S. patent application Ser. No. 10/728,560 filed on Dec. 5, 2003 which is a Continuation-in-Part of U.S. patent application Ser. No. 10/335,552 filed on Dec. 31, 2002 which claims the benefit of priority of U.S. Provisional Patent Application Ser. No. 60/344,869, filed Dec. 31, 2001, and entitled "Pharmaceutical Compounder and Information Management System".

[0002] A portion of the disclosure of this patent document contains material which is subject to copyright protection. The copyright owner has no objection to the facsimile reproduction by anyone of the patent document or the patent disclosure, as it appears in the Patent and Trademark Office patent file or records, but otherwise reserves all copyright rights whatsoever.

FIELD OF THE INVENTION

[0003] This invention relates to a method for interfacing a compounder used to compound liquids and/or drugs intended to be administered to a human being or an animal with a prescription/order entry system.

BACKGROUND OF THE INVENTION

[0004] Pharmaceutical compounding involves the transfer of two or more of individual prescribed liquids and/or drugs from multiple source containers into a single collecting container, for the purpose of administering the mix of liquids and/or drugs intravenously to an individual in need. Presently, the pharmaceutical compounding of liquids and/or drugs takes place primarily at one of three sites. There are: (1) hospital based compounding performed by pharmacists or pharmacy technicians in the hospital pharmacy; (2) alternate site based compounding performed primarily by pharmacists or pharmacy technicians in the home care company pharmacy; and (3) compounding centers operated by any one of several major pharmaceutical or hospital supply companies.

[0005] The operational and performance demands upon these compounding systems and methodologies are becoming increasingly more complex and sophisticated, in terms of, e.g., safety, speed, reliability, accuracy, and overall user friendliness and ergonomics. The operational and performance demands upon these compounding systems and methodologies are also becoming increasingly more complex and sophisticated with regard to the management of patient and prescription information, in terms of providing an information path that starts with the clinician and finishes with the final product delivery to the end patient.

[0006] Interfacing of the system used by the doctor for example to enter a compound prescription/order for a patient has become a problem. Especially so where the order system is part of a larger system to which the compounder is not connected. Conventionally, in these situations the order is written or otherwise entered into the ordering system. The written order is then checked by the prescribing doctor or clinical pharmacist for accuracy. After approval, this printed order is provided to the pharmacy where it must now be reentered into the compounder system. The transcription of

the written order is a source for errors resulting in a compound that does not match the intended prescription.

[0007] Alternatively, there are systems in place that electronically couple the order entry system and the pharmaceutical compounder. These systems, however, are complex and in the case of systems that do not share a common data protocol, require a translation interface. Further, these systems may not be desirable where autonomy of existing systems is required.

[0008] Therefore, what is needed is a system and method that addressed the problems of the prior art and provides for inputting of compounding data into a pharmaceutical compounded such that transcription errors are minimized if not eliminated entirely.

SUMMARY OF THE INVENTION

[0009] In view of the shortcomings of the prior art, the present invention is a system and method providing input data to a pharmaceutical compounding device having an associated plurality of source solutions.

[0010] One method comprising the steps of generating with said data entry system includes a first label comprising first indicia defining an allocation of said plurality of source solutions conforming to either a predetermined or undefined configuration; providing said first indicia to said pharmaceutical compounding device as an input; and generating a pharmaceutical compound based on said indicia input into said pharmaceutical compounding device.

[0011] According to another aspect of the invention, further steps include generating a second label comprising second indicia indicative of at least said pharmaceutical compound; providing said second indicia to said data entry device as an input; and comparing said allocation of said plurality of source solutions with said second indicia in said data entry device.

[0012] Another aspect of the invention provides generating a first output if it is determined that a mismatch of said allocation of said plurality of source solutions and said pharmaceutical compound has occurred.

[0013] Another aspect of the invention provides generating a second output if it is determined that the allocation of said plurality of source solutions and matches the allocation of source solution in the pharmaceutical compound.

[0014] According to another aspect of the invention the second indicia also comprises information relating to a patient for which the pharmaceutical compound is intended.

[0015] According to another aspect of the invention at least one of the first indicia and/or the second indicia comprises a bar code.

[0016] According to yet another aspect of the invention, either or both labels are RFID tags and the indicia associated with the tags is stored in electronic form therein.

[0017] Another aspect of the invention is a system for providing input data to a pharmaceutical compounding device having an associated plurality of source solutions. The system comprises means for generating a first output comprising first information defining at least an allocation of said plurality of source solutions conforming to a predetermined configuration; means for transferring said first information into said pharmaceutical compounding device; means for generating a pharmaceutical compound based on said first information; means for generating a second output comprising second information indicative of at least said pharmaceutical compound; means for comparing said second information with

said first information; and means for determining if said pharmaceutical compound matches said predetermined configuration.

[0018] According to another aspect of the invention, either or both of the first and second information are in electronic form stored in respective RFID tags.

[0019] Other features and advantages of the inventions are set forth in the following specification and attached drawings.

BRIEF DESCRIPTION OF THE DRAWINGS

[0020] The invention is best understood from the following detailed description when read in connection with the accompanying drawing. It is emphasized that, according to common practice, the various features of the drawing are not to scale. On the contrary, the dimensions of the various features are arbitrarily expanded or reduced for clarity. Included in the drawing are the following Figures:

[0021] FIG. 1 is a perspective view of a pharmaceutical compounding system that includes a compounding device that, in use, mixes or compounds two or more selected liquids and/or drugs intended to be administered to a human being or an animal.

[0022] FIG. 2A is a view of a disposable transfer set that can be used in association with the compounding device shown in FIG. 1.

[0023] FIGS. 2B and 2C are enlarged views, partially broken away and in section, of an embodiment of a manifold that the transfer set shown in FIG. 2A can incorporate to mediate against back flow of liquid in the manifold and lipid hazing.

[0024] FIGS. 2D and 2E are enlarged views, partially broken away and in section, of another embodiment of a manifold that the transfer set shown in FIG. 2A can incorporate to mediate against lipid hazing.

[0025] FIG. 2F is a view of a portion of the disposable transfer set shown in FIG. 2A, which includes a transfer tube organizer to facilitate use of the transfer set with the compounding device shown in FIG. 1.

[0026] FIG. 3 is a perspective view of the system shown in FIG. 1 with the transfer set shown in FIG. 2A mounted for use on the compounding device.

[0027] FIG. 4 is a perspective view of the compounding device shown in FIG. 1, with its peristaltic pumping station open for loading a transfer set of the type shown in FIG. 2A.

[0028] FIG. 5 is a perspective view of a compounding device shown in FIG. 4, with a transfer set mounted in the peristaltic pumping station.

[0029] FIG. 6A is a perspective side view of the compounding device shown in FIG. 4 with its exterior case removed to show the peristaltic pump components and other internal components.

[0030] FIG. 6B is an exploded perspective view of the peristaltic pump components shown in FIG. 6A.

[0031] FIG. 7 is a top view of the compounding device shown in FIG. 6A.

[0032] FIGS. 8A to 8F are schematic views of alternative configurations of linked and/or networked systems that incorporate the compounding device shown in FIG. 1.

[0033] FIGS. 9A to 9W are representative screens of a graphical user interface that a compounding control manager function residing on the compounding device shown in FIG. 1 can generate in the process of enabling and controlling a compounding procedure.

[0034] FIGS. 10A to 10E are system flow charts of representative functional modules of an order entry process man-

ager function that, when used in association with the compounding control manager function of the compounding device shown in FIG. 1, provides enhanced compounding order entry and processing capabilities that can be accessed by browsers installed on remote workstations.

[0035] FIGS. 11A to 11J are representative screens of a browser-based graphical user interface that makes accessible to a remote workstation the functional modules of the order entry process manager shown in FIGS. 10A to 10E.

[0036] FIG. 12 is a representative view of labeling that the order entry process manager shown in FIGS. 10A to 10E and FIGS. 11A to 11J can generate.

[0037] FIG. 13 is a schematic view of a controller that the compounding device shown in FIG. 1 can incorporate, which can execute the compounding control manager and order entry process manager functions shown in FIGS. 9A to 9W; 10A to 10E; 11A to 11J.

[0038] FIGS. 14A-14B are representative screens of a training/help video-audio function that can be integrated with the compounding control manager of the compounding device shown in FIG. 1.

[0039] FIG. 15A-15B are representative screens related to configuration of the exemplary system.

[0040] FIG. 16 is a representative screen illustrating the freeze screen function of the exemplary system.

[0041] FIG. 17 is a representative screen illustrating the check list function of the exemplary system.

[0042] FIG. 18A-18B are representative screens illustrating the infusion pump selection function of the exemplary system.

[0043] FIG. 19 is a representative screen illustrating the nutritional assessment function of the exemplary system.

[0044] FIG. 20A-20B are representative screens illustrating the physician entry/selection function of the exemplary system.

[0045] FIG. 21A-21B are representative screens illustrating the additive solution function of the exemplary system.

[0046] FIG. 22 is a block diagram of an exemplary embodiment illustrating transfer of information for an ordering system to a pharmaceutical compounding of the present invention.

[0047] FIGS. 23A-23B are examples of a barcode output from the order entry device of the exemplary data transfer system.

[0048] FIG. 24 is an example of an output from the pharmaceutical compounding of the exemplary data transfer system.

DETAILED DESCRIPTION OF THE INVENTION

[0049] FIG. 1 shows a pharmaceutical compounding system 10. The system 10 can be used for mixing or compounding two or more selected liquids and/or drugs intended to be administered to a human being or an animal. In use, the system 10 serves to transfer two or more of individual prescribed liquids and/or drugs from multiple source containers (e.g., individual vials, bottles, syringes, or bags) into a single collecting container (e.g., a bottle, syringe, or bag), so that the mix of liquids and/or drugs can be administered (e.g., intravenously) to an individual in need.

[0050] As one example, due to injury, disease, or trauma, a patient may need to receive all or some of their nutritional requirements intravenously. In this situation, the patient will typically receive a basic solution containing a mixture of amino acids, dextrose, and fat emulsions, which provide a major portion of the patient's nutritional needs, which is

called total parenteral nutrition, or, in shorthand, TPN. In this arrangement, a physician will prescribe a mixture of amino acids, dextrose, and fat emulsions to be administered, as well as the frequency of administration. To maintain a patient for an extended period of time on TPN, smaller volumes of additional additives, such as vitamins, minerals, electrolytes, etc., are also prescribed for inclusion in the mix. Using the system 10, under the supervision of a pharmacist, the prescription order is entered and individual doses of the prescribed liquids, drugs, and/or additives are accordingly transferred from separate individual source containers for mixing in a single container for administration to the individual.

[0051] There are other environments where the system 10 is well suited for use. For example, in the medical field, the system 10 can be used to compound liquids and/or drugs in support of chemotherapy, cardioplegia, therapies involving the administration of antibiotics and/or blood products therapies, and in biotechnology processing, including diagnostic solution preparation and solution preparation for cellular and molecular process development. Furthermore, the system 10 can be used to compound liquids outside the medical field.

[0052] Nevertheless, for the purpose of explaining the features and benefits of the system 10, the illustrated embodiment describes use of the system 10 in support of TPN.

I. System Overview

[0053] The system 10 includes three principal components. These are (i) a liquid transfer set 12 (see FIG. 2A), which, in use, couples a final solution container 14 to individual solution source containers 16; (ii) a compounding or solution mixing device 18 (see FIG. 1), which, in use (see FIG. 3), interacts with the transfer set 12 to transfer liquids from the solution source containers 16 into the final solution container 14; and (iii) a controller 20 (see FIG. 1) that governs the interaction to perform a compounding or solution mixing procedure prescribed by a physician, which is typically carried out by a trained clinician at a compounding site under the supervision of a pharmacist.

[0054] The compounding device 18 and controller 20 are intended to be durable items capable of long-term use. In the illustrated embodiment (see FIG. 1), the compounding device 18 is mounted inside a housing or case 22, and the controller 20 is mounted, in most part, within a control panel 24 mounted to a surface outside the case 22. The case 22 presents a compact footprint, suited for set up and operation upon a tabletop or other relatively small surface. The case 22 and panel 24 can be formed into a desired configuration, e.g., by molding or forming. The case 22 and panel 24 are preferably made from a lightweight, yet durable material, e.g., plastic or metal.

[0055] The transfer set 12 (FIG. 2A) is intended to be a sterile, single use, disposable item. As FIG. 3 shows, before beginning a given compounding procedure, the operator loads the various components of the transfer set 12 in association with the device 18.

[0056] As illustrated, the device 18 includes a weigh station 26 that, in use, carries the final solution container 14 (as FIG. 3 shows). The weigh station 26 includes a support arm 28 (as FIG. 4 shows), which in the illustrated embodiment, is attached to a side or bottom of the case 22. The weigh station 26 also includes a conventional load cell 30, which suspends from a top of the support arm 28. During compounding, the final solution container 14 hangs from a hanger H on the load cell 30 (see FIG. 3). As also illustrated, the device 18 may

include, but does not require, a source solution support frame 32. The support frame 32 carries several individual hangers H, which, during compounding, support the individual source containers 16. When a source solution support frame 32 is not included in device 18, other means can be used to support the individual source containers 16.

[0057] As illustrated, the support frame 32 comprises a separate component; however, the support frame 32 can be attached in a suitable manner to the case 22. Typically, during compounding, the device 18, with source containers 16 and final container 14, are located within a laminar flow hood in a "clean room" environment.

[0058] The transfer set 12 shown in FIG. 2A can in general include lengths of source transfer tubing 34, which are joined at one end to a common junction or manifold 36. The opposite ends of the source transfer tubing 34 each includes a spike 38 or suitable releasable coupling, which can be inserted in conventional fashion through a diaphragm carried by the associated source solution container 16, to open flow communication between that source solution container 16 and the respective source transfer tubing 34. A length of final transfer tubing 40 is coupled to the final solution container 14. The opposite end of the final transfer tubing 40 includes a spike 42 or suitable releasable coupling, which can be inserted into an outlet 44 in the manifold 36, to couple the final solution container 14 to the source solution containers 16. The source transfer tubing 34 and the final transfer tubing 40 can be made from flexible, medical grade plastic material, such as polyvinyl chloride plasticized with di-2-ethylhexyl-phthalate. One or more of the source containers 16 or final containers 14 can likewise be made from medical grade plastic material selected for inertness and compatibility with the intended source solution. Likewise, one or more of the source or final containers 16 or 14 can be made from glass.

[0059] Each source transfer tubing 34 includes an in-line pump segment 46 between the spike 38 and the manifold 36. The pump segments 34 can be made, e.g., from silicone rubber. Each source transfer tubing 34 also includes an in-line, one way valve 48 (e.g., a duckbill, disk, or umbrella valve)—which, in the illustrated embodiment, is carried within the manifold 36 (see FIG. 2B)—which permits liquid flow from the source containers 16 toward the manifold 36, but prevents backflow from the manifold 36 toward any of the source containers 16. Each valve 48 opens in response to forward fluid flow, to allow liquid flow into the manifold 36 and through the spike-receiving outlet 44 (i.e., toward the final solution container 14). Each valve 48 closes in response to back flow of liquid in the manifold 36 from the outlet 44 or other source transfer tubing 34.

[0060] Each pump segment 46 is designed for use in association with a peristaltic pump rotor. Accordingly, as FIG. 4 shows, the compounding device 18 includes a peristaltic pumping station 50. As FIG. 4 shows, the peristaltic pumping station 50 occupies a pump bay 52 or compartment formed in the device. As shown, the peristaltic pumping station 50 includes an axial array of individual peristaltic pump rotor assemblies 54, although non-axial arrays can be used. Furthermore, the pumping station 50 can include multiple side-by-side banks of peristaltic pump rotor assemblies 54.

[0061] The peristaltic pumping station 50 includes a door 56, which opens and closes the pump bay 52. The door 56 opens (as FIG. 4 shows) to allow loading of a selected one of the pump segments 46 in association with a selected one of the peristaltic pump rotor assemblies 54, as FIG. 5 shows. The

door closes (as FIG. 3 shows) to enclose the peristaltic pumping station 50 during operation. Desirably, the controller 20 is coupled to an electrical interlock 66 (see FIG. 13) to prevent operation of the peristaltic pump rotor assemblies 54 when the door 56 is opened.

[0062] The controller 20 executes a compounding protocol or procedure based upon prescribed data entry orders and preprogrammed pump control rules, which also can include other input from the operator. During operation, the peristaltic pump rotor assemblies 54 are individually, selectively operated in series—or simultaneously, selectively operated in parallel—as dictated by the controller 20, to transfer desired amounts of source solutions from the individual source containers 16 through the manifold 36 and into the final container 14. The load cell 30 is coupled to the controller 20, to gravimetrically monitor the incremental transfer of the individual source solutions into the final container 14. The controller 20 monitors incremental changes in weight, which are processed according to preprogrammed rule to govern the speed at which a given peristaltic pump assembly 54 is operated and, ultimately, stopped when the prescribed amount of source solution is delivered.

[0063] The controller 20 (see FIG. 13) comprises a main processing unit (MPU) 58. The MPU 58 comprises a conventional PC that is, in the illustrated embodiment, mounted within the control panel 24, outside the case 22 of the compounding device 18. Alternatively, the MPU 58 could be mounted within the case 22 of the compounding device 18. The MPU 58 can comprise one or more conventional microprocessors that support the Microsoft®. Windows®. operating environment. The MPU 58 includes conventional RAM 122 and a conventional nonvolatile memory device 74, such as a hard disk drive. The MPU 58 includes an input device 124 to upload programs into the memory device 74, e.g., a CD-reader. In the illustrated embodiment, a compounding control manager function 72 resides as process software in the memory device 74 of the MPU 58.

[0064] In the illustrated embodiment, the controller 20 also includes a supervisor CPU 126 and peripheral processing unit (PPU) 60. Both the CPU 126 and PPU 60 are desirably implemented on a printed circuit board. The CPU comprises a conventional microprocessor capable of running the uC/OS-II operating system. The PPU is a dedicated microchip PIC, driven by firmware specific to its processing tasks and control functions. In the illustrated embodiment, the CPU 126 and PPU 60 are mounted inside an electronics bay 62 or compartment with the case 22 of the compounding device 18 (see FIGS. 6A, 6B, and 7). An AC power supply (not shown) supplies electrical power to the CPU 126, PPU 60, and other electrical components of the device 18.

[0065] The CPU 126 is coupled via a USB, RS-232, or Ethernet port, or other connective means, to the MPU 58 (see FIG. 13). The CPU 126 receives high-level instructions from the MPU 58 generated by the compounding control manager 72. The PPU 60 (see FIG. 13) is coupled via an RS-232 link to the CPU 126. The high-level instructions generated by the compounding control manager 72 are conveyed by the CPU 126 as medium level commands to the PPU 60. The PPU 60 is connected to various hardware of the peristaltic pump station 50 and weigh station 26—e.g., the door interlock 66 (as previously described), a pump motor 64 (see also FIG. 6A, as will be described later), pump clutches 68 (as will be described later), Hall effect pump rotor sensors 70 (as will also be described later), the load cell 30 (previously described), etc.

The PPU 60 provides hardware-specific commands, based upon the medium level control commands generated by the CPU 126, as well as a first level of safeguards (e.g., to stop the pump motor 64 if the door 56 is open, as previously described). The PPU 60 and CPU 126 communicate with and monitor each other, to backup individual failures and take corrective action.

[0066] The compounding control manager 72 resides on the MPU 58. The compounding control manager 72 includes preprogrammed rules that prescribe procedures for receiving and manipulating input data, monitoring device status and operating conditions, outputting or storing data, and commanding operation of the peristaltic pump station 50 to achieve prescribed compounding tasks. The MPU 58 communicates high level instructions to the CPU 126 (e.g., the amount of liquid each peristaltic pump assembly 54 is to convey), which are created by the compounding control manager 72 in response to operator input. The CPU 126, in turn, communicates medium level instructions to the PPU 60, which communicates specific pump commands to the peristaltic pump assemblies 54 to carry out the pumping instructions, well as receives and evaluates operational status data from sensors and the load cell, to generate closed-loop feedback control and corresponding alarms. The PPU 60 also relays operational status data to the CPU 126, which also evaluates the operational status data in parallel with the PPU 60. In this respect, the CPU 126 provides a second level of safeguards if an alarm condition is not detected by the PPU 60 (e.g., to halt pumping if over-delivery—not otherwise sensed by the PPU 60—is occurring).

[0067] In the illustrated embodiment (see FIG. 1), the controller 20 includes a display device 76, which is part of the control panel 24, data entry devices 78 (e.g., a keyboard and a mouse), and a data output station 80 (e.g., a printer), which are coupled via appropriate inputs and outputs to the MPU 58. In the illustrated embodiment (see FIG. 1), the display device 76 also desirably serves as another data entry device using, e.g., conventional touch screen methodologies implemented by the compounding control manager 72 using a Windows®. -based operating platform resident in the compounding control manager 72. The combined data display and data entry capabilities that the compounding control manager 72 executes in this arrangement provide an interactive user interface on the display device 76 that, under preprogrammed rules resident in the compounding control manager 72, accepts data entry and displays for the operator information prompting or confirming the entered data, as well as monitored operational status and conditions of the compounding device 18. The compounding control manager 72 also provides a third level of safeguards by verification of the original order with the actual pump delivery results. The display can be in alpha-numeric format and/or as graphical or pictorial images, as desired. The compounding control manager 72 also enables output of selected information to the printer 80 in a desired format, e.g., as activity reports. The interactive user interface of the compounding control manager 72 allows the operator to conveniently enter, view, and assimilate information regarding the operation of the system 10. Further details of the compounding control manager 72 and the touch screen interactive user interface that can be implemented by the compounding control manager 72 will be described later.

[0068] As also shown in FIG. 1, the MPU 58 also includes an input for a bar code reader 82 or the like, for scanning information into the compounding control manager 72. In

embodiments that include RFID tags, rather than bar coded indicia, a commercially available RFID reader (not shown) is substituted for bar code reader 82. Further details of this aspect of the system 10 will be described later.

[0069] As FIG. 1 also shows, the MPU 58 also includes input for keyboard and mouse data entry devices 78. These devices 78 allow the operator to enter data for manipulation by the compounding control manager 72 and to interact with information presented by the display device 76 in different ways, and without use of the touch screen data entry capabilities of the compounding control manager 72. In this arrangement (see FIG. 13), the controller 20 desirably includes an order entry process manager 84, which can reside on the memory device 74 of the MPU 58 in the control panel 24. The order entry manager 84 makes possible other forms of interactive data entry and data viewing platforms, as well as other forms of data output to the printer 80 in a selected format, e.g., as labeling for the final solution container 14, as will be described in greater detail later.

[0070] Desirably (as FIG. 13 shows), the order entry process manager 84 can be accessed by browser software 86 residing on one or more external microprocessors 88 linked to the compounding control manager 72 of the device controller 20. In this arrangement, the controller 20 desirably includes an RS-232 link or another alternative data communication connections (e.g., radio, microwave, infrared, or other electromagnetic wave communication systems), to enable electronic or electromagnetic data communication between the compounding control manager 72 and external input or output devices (e.g., other data entry workstations and/or printers), using, e.g., single-station hubless local area network connections, multiple-station hub or switch local area network connections, multiple-station hub connections with facility network servers, and/or multiple-station connections through the public internet. Conversely, or in addition, multiple compounding devices 18 can be linked through their onboard controllers to multiple data entry workstations or sites. These capabilities of the controller 20 make diverse arrangements of fully networked pharmaceutical compounding possible. Further details of these networked forms (e.g., internet, intranet, or loopback) of interactive data entry and data viewing platforms, that can be accommodated by the controller 20 in association with the compounding control manager 72, will be described later.

[0071] Upon completing a compounding procedure, the operator seals the inlet tubing 40 of the final solution container 14 and detaches the final transfer tubing spike 42 from the manifold 36. When there are a series of compounding orders that require mixtures of at least some of the same source solutions, which typically is the case, the operator will proceed to the next compounding order by attaching the spike 42 of the inlet tubing 40 of a new final solution container 14 to the manifold 36 and executing another compounding procedure. Otherwise, the operator can decouple the source transfer tubing 34 from the source containers 16 and remove the transfer set 12 and source containers 16 from association with the device 18. The transfer set 12 can be discarded. Each final solution container 14, and its compounded liquid contents, is retained for storage, infusion, transfusion, or further processing.

II. Technical Features of the Compounding Device

[0072] FIGS. 6A, 6B, and 7 best show the details of construction of a representative embodiment of the compounding

device 18. As illustrated, the device 18 includes a frame 90 that is divided into the pump bay 52 and the electronics bay 62, as previously described. Hardware components of the peristaltic pumping station 50 occupy the pump bay 52. The electrical components of the pumping station 50 the load cell 30, as well as the PPU 60, occupy the electronics bay 62. The case 22 shown, e.g., in FIGS. 4 and 5, encloses the frame 90 and the components it carries.

[0073] A. The Peristaltic Pumping Station

[0074] Within the pump bay 52, the peristaltic pumping station 50 includes an array of peristaltic pump rotor assemblies 54, as already generally described. The number and configuration of peristaltic pump rotor assemblies 54 can vary according to design considerations and the compounding requirements of the device 18. In the illustrated embodiment (shown in FIG. 4), there are nine peristaltic pump rotor assemblies 54.

[0075] As illustrated (see FIGS. 6A and 6B), each peristaltic pump rotor assembly 54 is constructed in the same manner. Each assembly 54 is supported on a bearing plate 92 secured to the frame 90. The bearing plates 92 are arranged sequentially in an axial spaced relationship along a drive shaft 94. The drive shaft 94 is coupled at one end to the electric drive motor 64 (see FIG. 6A) (carried in the electronics bay 62) via a drive belt 96 and drive pulley 98. Alternatively, the drive shaft 94 can be coupled directly to the drive motor 64. Operation of the drive motor 64, which is governed by the controller 20, rotates the drive shaft 94 at a desired rate of rotation. In a representative implementation, the drive motor can rotate the drive shaft 94 at variable rates. Each pump rotor assembly 54 includes a drive gear 100, which is carried by a bearing 102 on the drive shaft 94. A conventional electro-magnetic clutch assembly 68 is coupled to each drive gear 100. Each clutch assembly 68 is individually coupled to the controller 20 (as FIG. 13 shows). When actuated by the controller 20, a given clutch assembly 68 frictionally couples the drive gear 100 to the drive shaft 94, causing rotation of the drive gear 100. When the clutch assembly 68 is not actuated by the controller 20, rotation of the drive shaft 94 is not imparted to the associated drive gear 100.

[0076] A fixed idler shaft 104 extends through the bearing plates 92 on a bushing 108, spaced from and offset from the drive shaft 94. Each pump rotor assembly 54 also includes a driven gear 106. The driven gears 106 are individually coupled to the drive gears 100, such that rotation of a given drive gear 100 will impart rotation to its respective driven gear 106. In this arrangement, each pump rotor assembly 54 includes a pump rotor 110 coupled (e.g., by gear attachment screws 112) for rotation with each driven gear 106. Each pump rotor 110 carries an array of pump rollers 114, which, in use, engage an in-line pump segment 46 of the transfer tubing 34.

[0077] Actuation of a given clutch assembly 68 by the controller 20 couples the associated drive gear 100 to the drive shaft 94—to which rotation is imparted by the drive motor 64—which, in turns, imparts rotation through the driven gear 106 to the associated pump rotor 110. During rotation of the pump rotor 110, the pump rollers 114 engage the associated pump segment 46 and convey liquid through the transfer tubing 34 by well-understood peristaltic pumping action.

[0078] Each pump rotor assembly 54 includes a pair of holding brackets 116 aligned with the associated pump rotor 110. The holding brackets 116 are sized and configured to

releasably mate with mounts 118 (see FIG. 2A) formed on opposite ends of each pump segment 46. The holding brackets 116 frictionally engage the pump segment mounts 118, and thereby hold the pump segments 46 in desired operative association with the pump rollers 114 during use, as FIG. 5 shows.

[0079] As will be described in greater detail later, the holding brackets 116 of the pump rotor assemblies 54 and pump segment mounts 118 of the transfer tubing 34 are desirably uniquely coded (e.g., by matching numbers and/or by a matching color or the like) to prompt a desired order to the mounting of a selected pump segment 46 in relation to a selected pump rotor 110. The unique matching code is also carried by the spike 38 of the associated transfer tubing 34 (e.g., by a numbered, colored tab 120), to prompt a desired coupling of the transfer tubing 34 in relation to a selected source container 16. As will be described in greater detail later, the graphics of the user interface generated by the compounding control manager 72 desirably incorporates this unique code, thereby matching the disposable components of the transfer set 12 with the hardware components of the pump station 50, as well as with the desired software functionality provided by the compounding control manager 72.

[0080] Desirably, the unique matching code includes for example bar-code indicia, e.g., one or two-dimensional bar code. Alternate embodiments may employ other types of indicia, such as RFID tags for example, into which the information is stored. In this arrangement, the compounding control manager 72 can require the operator to perform the physical act of scanning in bar code indicia on a source solution container and on the transfer set, to eliminate potential error sources prior to compounding. This marriage between software, hardware, and disposable components minimizes sources of compounding errors due to human error. Bar code scanning can also desirably include determining lot number recording prior to compounding, and warning/preventing use of a source solution that has an expired date or will become expired within a predetermined period. As such, recording of solution lot numbers can be automated and tied to the compounded bag and the waste of valuable source solutions is avoided as well as avoiding the possibility of providing a final solution that may not be as effective as a solution that did not contain an expired component.

[0081] As shown in FIG. 2F, the transfer set 12 can also include a tubing organizer 128, which comprises a molded or fabricated strip of plastic sized and configured to capture, as a unit, all the transfer tubing 34 between the pump segments 46 and the spikes 38 in a desired order. In this arrangement, the organizer 128 requires the operator to mount the pump segments 46 as a unit to the holding brackets 116, with the order of the transfer tubing 24 with respect to the pump rotor assemblies 54 preordained by the organizer 128. The organizer 128 further assures that the transfer tubing 34 is loaded in a desired order on the compounding device 18.

[0082] The system 10 makes possible systematic process control at every stage of the compounding process, starting at the physician order point and continuing through compounding and final product delivery and receipt. As above described, orders can be received from the patient site via hospital based electric ordering systems. Upon the electronic receipt of data, such data can be entered or transmitted electronically into the compounding control manager 72. Final solution containers 14 can be labeled automatically as the step preceding the compounding process. The compounding process can thereafter be controlled and verified through

labeling on the final solution container 14 in combination with source container labeling and bar coding.

[0083] B. Pump Control Criteria

[0084] As has been generally described, and as will be described later in greater detail, a desired compounding order is entered by an operator, and the compounding control manager 72 in the MPU 58 of the control panel 24 executes the compounding order. Typically, the compounding order identifies the source solutions and the amounts of each source solution (by weight or volume) that are to be mixed in the final solution. The compounding control manager 72 can operate the individual pump rotor assemblies 54 (through the PPU 60 in the compounding device 18) in a serial compounding mode, i.e., operating a first pump rotor assembly 54 to convey the desired amount of a first source solution into the final container 14, then next operating a second pump rotor assembly 54 to convey the desired amount of a second source solution into the final container 14, and so on until the desired amount of each source solution has been delivered to comprise the desired mixture.

[0085] In controlling the individual pump rotor assemblies 54, the preprogrammed rules of the compounding control manager 72 desirably take into account pre-established delivery accuracy criteria. The criteria can vary according to the compounding tasks to be accomplished. For example, for TPN, delivery accuracy criteria can be established of $\pm 5\%$, or better, for any ingredient of 0.2 mL or more. A delivery accuracy criteria of $+5\%/ -0\%$ could be established to eliminate the possibility of underfills.

[0086] The preprogrammed rules of the compounding control manager 72 also desirably include a delivery time criteria that takes into account the delivery volume. Keeping absolute errors as small as possible is mandated at smaller delivery volumes to achieve a system delivery accuracy goal of $\pm 5\%$ or better. Such smaller absolute delivery errors require the compounding control manager 72 to incorporate tighter process control, which, for smaller delivery volumes, can result in longer delivery times per mL of delivery. However, larger absolute errors are acceptable at larger delivery volumes to achieve a system delivery accuracy goal of $\pm 5\%$ or better. For example, a 1% error on a 10 mL delivery is 0.1 mL. The same 1% error on a 1000 mL delivery is 10 mL. Thus, the compounding control manager 72 can institute different process control for larger volumes, which, for larger delivery volumes, can result in a faster delivery times per mL of delivery.

[0087] The compounding control manager 72 can also accommodate parallel processing of the same source solution. For example, if the same source solution is present on two pump rotor assemblies 54, both source solutions can be pumped in parallel (at the same time) to shorten overall delivery time. Thus, if it takes two minutes to fill a single container using serial compounding (i.e., one solution after the other), it is expected that parallel compounding can potentially reduce this time requirement down to one minute, depending upon the solution components that comprise the final product.

[0088] The preprogrammed rules of the compounding control manager 72 institute desirable closed-loop control of the pump drive motor 64. The closed-loop control desirably implement convention proportional-integral-derivative (PID) control schemes to control pump speed to achieve a desired target delivery. The PID control schemes generate pump correction commands that take into account not only the absolute difference between the present delivery amount and the target

amount, but also the how quickly the absolute difference is changing over time. The control schemes can use a purely mathematical PID model, or they can incorporate “fuzzy logic” techniques, making use of estimations and interpolations to determine how to adjust the motor speed to obtain the desired flow rate. Use of fuzzy logic techniques permit a motor speed control function without use of multiply and divide instructions, thereby minimizing processing complexity.

[0089] Shown below is the fundamental PID equation is, where ‘e’ is the error between the desired motor speed and the actual motor speed and ‘u’ is the new motor drive power level to try to adjust for the error:

$$u = K_P e + K_I \int e dt + K_D \frac{de}{dt} \quad \text{Eq. 1}$$

[0090] where:

[0091] (P)roportional—The proportional (direct) response to motor speed error.

[0092] (I)ntegral—The integral (quick speed change) to difference between the desired speed and actual speed. This normally comes into play at motor start-up, where the motor power needs to go from zero to full power very quickly.

[0093] (D)erivative—The derivative (accumulated) response to motor speed error. This is what causes the motor power to steadily increase as necessary in the presence of high loads, for example.

[0094] In Eq. 1, an integer math approximation of the error between the desired motor speed and the projected motor speed is performed based on the current motor speed and acceleration. This error value is then used to adjust the motor drive power level up or down as appropriate.

[0095] By using the absolute error value (scaled appropriately) as the motor power adjustment value, the (P)roportional part of the PID equation is approximated.

[0096] By the choice of value ranges and scales, the (I)ntegral part of the PID equation is approximated. This is accomplished by making the error value scale large compared to the motor drive power, so that a moderate error value (much less than the maximum possible error) drives the motor power level to saturation.

[0097] Furthermore, by adjusting the motor drive power level instead of determining a new motor drive power level at each PID control loop iteration, the (D)erivative contribution of the PID equation is approximated.

[0098] This results in a motor control algorithm that performs like a conventional PID algorithm, with improved transient response and smooth control.

Quadrature Decoder Implementation

[0099] Unlike a conventional quadrature decoder, our decoder does not generate Up and Down pulses to pump drive motor 64; rather it simply determines the direction that pump drive motor 64 is currently spinning. The PPU 60 monitors the direction signal and statistically determines if the motor is spinning in the programmed direction, and generates an alarm if not. This results in the use of a minimum number of parts to implement the quadrature decoding function, which in conventional systems, require additional PPU inputs or more expensive external parts.

[0100] In one representative implementation, the compounding control manager 72 conducts a high speed flow rate control regime until the absolute difference between the volume delivered and the target approaches a preset amount. At this “slow down” point, the compounding control manager 72 ramp-downs the flow rate and conducts a low speed flow rate control regime. During this regime, the correction commands become successively smaller as the difference between the volume delivered and the target diminishes. The rate of the flow rate reduction during this regime can be linear or non-linear, and the slope of the non-linear reduction can be either concave, or convex, or a combination thereof.

[0101] In a desired implementation, the compounding control manager 72 steps or pulses the respective pump rotor assembly as the target volume is approached. In this arrangement, the PPU 60 can communicate with rotor rotation sensors 70, such as Hall effect sensors coupled to each rotor, so that a rotor revolution can be correlated with a number of incrementally sensed steps, which, in turn, can be correlated with incremental degrees of rotor rotation—e.g., one full revolution (360 degrees) equals five hundred incrementally sensed steps, so each incrementally sensed step equals 0.72 degrees of rotation. In this way, the PPU 60 can generate very precise pump commands in terms of small incremental units of pump rotor rotation when the target volume is approached, to prevent an overflow such as that caused by hydraulic effect whereby the tubing of the transfer set will return to its normal cross-section after pressure from pumping is removed.

[0102] The PPU 60 monitors the output of the Hall effect sensors to determine which rotor(s) are spinning. This information is used to generate appropriate alarms, such as:

[0103] 1. Rotor moving when it shouldn't be—this is a potential hazard because it can cause incorrect solution to be delivered to the final container. The exemplary system monitors for this condition and issues an alarm when it occurs, and advises the operator that the final container should not be used to treat a patient.

[0104] 2. Rotor not moving when it should be—this is not a hazard, but is detected and reported to the operator as a malfunction.

III. Technical Features of the Transfer Set

[0105] As before described, for a typical compounding session, there are usually a series of compounding orders that require mixtures of at least some of the same source solutions. In this arrangement, an operator will repeatedly exchange final solution containers 14 with the same manifold 36.

[0106] In these circumstances, a compounding order that requires a fat emulsion as a source solution can leave a fat emulsion residue in the manifold 36. This residue left in the manifold 36, although small in volume, can be introduced into the final solution container 14 of a subsequent compounding order, which may not specify a fat emulsion. The unintended residue causes what is generally called “lipid hazing” in the final solution container 14 of a compounding order that is supposed to be free of a fat emulsion.

[0107] To minimize the lipid hazing effect, in FIG. 2B, there is one transfer tubing 34' that is intended, during use, to be dedicated to the conveyance of a fat emulsion. As before explained, a unique coding arrangement, coupled with required bar code scanning (or RFID scanning where appropriate), can be incorporated to assure that this transfer tubing 34' is dedicated during use to the conveyance of fat emulsion from a source container. During compounding, fat emulsion

is conveyed into the final solution container **14** in advance of the other source solutions. Thus, the compounding of other source solutions after the fat emulsion serves to flush residual fat emulsion from the manifold **36** and into the final solution container **14**.

[0108] Following compounding, when the spike **42** is withdrawn from the outlet **44**, a temporary vacuum is created within the manifold **36**. The valves **48** can open in response to the temporary vacuum created by withdrawal of the spike **42** from the outlet **44**, drawing a small bolus of source solutions into the manifold **36**. A residue of fat emulsion can be included in this bolus.

[0109] In the illustrated arrangement, the valve **48'** in the manifold **36** that is in-line with the fat emulsion transfer tubing **34'** is sized and configured to have a valve opening or "cracking" pressure that is greater than the valve opening or cracking pressure of the other valves **48** in the manifold **36**, which are in-line with transfer tubing **34** that is not coupled to a fat emulsion source container. The greater cracking pressure of the valve **48'** that is in-line with the fat emulsion transfer tubing **34'** is selected to keep the valve **48'** closed when the spike **42** is withdrawn from the outlet **44**.

[0110] In use (as FIG. 2C shows), when a spike **42** is withdrawn from the outlet **44**, due to the lesser cracking pressures of the valves **48** that are not in-line with the fat emulsion transfer tubing **34'**, these valves **48** can open in response to the temporary vacuum created by withdrawal of the spike **42** from the outlet **44**. However, due to the greater cracking pressure of the valve **48'** that is in-line with the fat emulsion transfer tubing **34'**, the valve **48'** remains closed when the spike **42** is withdrawn from the outlet **44**. Thus, as the spike **42** is withdrawn and the temporary vacuum is created within the manifold **36**, the small bolus of source solutions from all the source containers that may be drawn into the manifold **36** will not include the fat emulsion. Thus, a residue of fat emulsion is prevented from entering the manifold **36** when the final solution container **14** is exchanged.

[0111] In an alternative arrangement (see FIGS. 2D and 2E), the peristaltic pump rotor assembly **54'** serving the one transfer tubing **34'** dedicated to the conveyance of fat emulsion can be capable of reverse rotation under the direction of the controller **20**. Reverse rotation creates a negative pressure and draws the in-line valve **48'** closed. In this arrangement, the controller **20** commands reverse rotation of the fat emulsion pump assembly **54'** prior to the operator removing the spike **42** from the outlet **44**. As FIG. 2E shows, removal of the spike **42** can open the valves **48**, except the valve **48'** in the fat emulsion tubing **34'**, which remains closed due to the counterforce of negative pump pressure. As before described, as the spike **42** is removed, a bolus of source solutions from all the source containers can be drawn into the manifold **36**, except for the fat emulsion.

[0112] The vacuum created by removal of the spike **42** can be augmented by pulsing the other peristaltic pump rotor assemblies **54** in a forward direction as the spike **42** is withdrawn. In this arrangement, the cracking pressure of the valve **48'** serving the fat emulsion transfer tubing **34'** need not be different than the cracking pressure of the other valves **48**.

IV. Technical Features of the Controller

[0113] A. The Compounding Control Manager

[0114] The compounding control manager **72** resides in the MPU **58** in the control panel **24**. The compounding control

manager **72** allows a clinician to enter, view, adjust and off-load information pertaining to a given compounding protocol.

[0115] In general, the compounding control manager **72** is the program language that provides the operator with real time feedback and interaction with the compounding device through graphic user interface (GUI) elements. The GUI elements, created in a Windows®-based graphical format, display the various inputs and outputs generated by the compounding control manager **72** and allow the user to input and adjust the information used by the compounding control manager **72** to operate the compounding device **18**.

[0116] To develop the GUI elements, the compounding control manager **72** can utilize certain third party, off-the-shelf components and tools. Once developed, the compounding control manager **72** can reside as a standard window-based software program on a memory device.

[0117] FIGS. 9A to 9W, 15A-15B, 16, and 17 are a walk-through of display screens generated by a representative embodiment of the compounding control manager **72**, which demonstrate various features of the compounding control manager **72**.

[0118] After an initial start-up mode of software initialization, a main work **10** area is created on the display device **76**, which initially opens a log-in screen **200** (FIG. 9A). The log-in screen **200** prompts the operator to identify himself, either by using the bar code or RFID scanner to scan an operator badge number, or by entry of a badge number or other selected form of identification on the graphical touch screen entry pad. This identification procedure is required for logging-in and/or assessing the operator's level of security clearance. Desirably, a system administrator would have previously established a list of authorized users, against which the sign-in data is compared.

[0119] The system desirably includes various set-up procedures that provide various safeguards for the operation of the system. FIG. 15A is one such configuration screen **1500** for setting up approvals required for all compounding operations. As shown in FIG. 15A, upon selection of tab **1502**, screen **1500** is presented to the operator, such as the administrator of the system or another individual that has such high level system administrative access. In this example, Screen **1500** presents a three tier selection for each of several classes of patients. Approval requirements are independent of one another across patient classes. Examples of approval levels are "NONE"—no approval necessary of any compounding function; "After Source Change"—Requiring approval from an upper level employee, such as a pharmacist, after any of the various source solutions are changed and/or replaced; "ALWAYS"—Requiring approval from an upper level employee for all compounding functions. The latter approval setting may be invoked for example for a new or junior level technician, or whenever such oversight is desired.

[0120] FIG. 15B illustrates Barcode Configuration screen **1504**. As shown in FIG. 15B, screen **1504** is presented to the operator upon selection of tab **1506** and allows the operator to set up the communication port via pull down **1508**, as well as permitting the selection of other attributes of the port, such as Port Speed, parity, word length, etc., via pull down **1510**. The operator is also presented with a variety of check boxes **1512** allowing the operator to select other check routines, such as requiring barcode confirmation before allowing compounding to start (**1514**); requiring source solution barcode confirmation at setup (**1516**); requiring source container barcode

confirmation after a no-flow alarm is indication (1518); and requiring final container label barcode confirmation (1520). The checks provide additional means to help avoid human error in the preparation of the final solution.

[0121] Once an authorized identification is entered, the login screen 200 is replaced by a main screen 202 (FIG. 9B). The main screen 202 displays sequentially numbered pump station data fields 204. The pump station data fields 204 are desirably numbered according to the left to right placement of the peristaltic pump rotor assemblies 54 in the compounding device. The numbers are also desirably color-coded according to the color code assigned to the peristaltic pump rotor assemblies 54 in the compounding device 18, as previously described.

[0122] Each pump station data field 204 includes a solution field 206 for the operator to identify what solution is to be delivered, as well as an amount field 208 to identify how much of that solution is to be delivered. The solution field 206 includes a touch button 210 that prompts TOUCH TO PROGRAM STATION. Touching the prompt button 210 allows to operator to enter data in the solution and amount fields 206 and 208 required by the compounding control manager 72.

[0123] Touching the prompt button 210 first opens a solution programming box 212 (FIG. 9C). The solution programming box 212 displays within the main screen 202 an array of touch buttons that either contain a specific identification of a solution type—e.g., DEX (dextrose); AMINO (amino acid); LIPID (fat emulsion); LYTES (electrolytes)—or allow the operator to specify another solution type (OTHER), or ask for a list of available solutions (LIST). Desirably, a system administrator would have previously established a list of solutions, using the OPTIONS MENU touch button 214 on the main screen 202, as will be described later. Other touch buttons in the solution programming box allow the operator to scroll through a list of solutions (PREVIOUS SOLUTION, NEXT SOLUTION). Another button (OK) allows for a verification of the identified solution and entry of that solution in the solution field 206, or an exit button (CANCEL) that closes the solution programming box 212 with no data entry in the solution field 206. Selection of a specific solution type button (e.g., DEX) (see FIG. 9D) either enters the only solution of its type on the list (i.e., Dextrose 70%), or, if there are various selections to be made (e.g., by selecting AMINO), displays a solution listing box 216 for that solution type (see FIG. 9E), from which the operator selects by touch.

[0124] Once the solution type has been selected, the operator selects the OK button on the solution programming box 212, and the solution type appears (see FIG. 9F) in the solution field 206 of the pump station data field 204. An amount programming box 218 is also opened (FIG. 9F), which replaces the solution programming box 212. The amount programming box 218 comprises a graphical numeric keypad, by which the operator can enter an amount expressed in a selected unit which is to be transferred by the selected pump station from the source solution container into the final container (e.g., volume, expressed in mL). The unit for the amount can also be specified by use of the DOSE CALCULATOR touch button 220. Once the numeric amount is entered, pressing the ENTER touch button in the amount programming box 218 enters the entered amount in the amount field 208 of the pump station data field 204 (see FIG. 9F), and the amount programming box 218 closes.

[0125] The station control box 222 (FIG. 9G) can also be optionally selected by pressing the station number identifica-

tion icon 224. The station control box 222 requires that the transfer of the solution identified in the solution field 206 be confirmed by the operator pressing the CONFIRM SOLUTION touch button 226. Pressing the CONFIRM SOLUTION touch button 226 opens a solution confirmation box 228 (FIG. 9H). The operator is prompted to scan a bar code on the source solution container (using the bar scanner input device 82). This bar code identifies, e.g., the solution type, the lot number of the solution, and its expiration date. By scanning the bar code, the compounding control manager 72 links this information to a specific compounding order for verification and solution tracking purposes. Furthermore, the compounding control manager 72 can implement expiration date control, locking out the use of expired solutions. The integration of the bar code scanning function with the compounding control manager 72 integrates lot number and expiration date tracking and/or verification to the operation of the compounding device 18.

[0126] The operator is also prompted to visually assure that the transfer tubing 34 having the unique coding corresponding to the pump station number is coupled to the source container from which the bar code is scanned, as well as scan the bar code component of the unique code on the transfer tubing 24 for that pump station. As confirmation of the correct source solution container 15 and transfer tubing 24 is made by the operator by scanning bar codes, information in the solution confirmation box 228 is updated (see FIG. 9I(1)). The operator is also prompted by screen 900, as shown in FIG. 9I(2), to confirm that the new transfer set has been installed and that it does not contain any solution is presented as option choice. Alternatively, if the operator is continuing to use the previous set up or a default setup to compound, the source solution setup screen 904 (FIG. 9I(3)) is presented at start-up asking the operator to make the appropriate selection as well as asking the operator to confirm that if a new transfer set was as installed, to ensure that the transfer set tubing is free of all solutions before proceeding. After full confirmation is accomplished, the operator can press an OK touch button in the solution confirmation box 228.

[0127] The solution flush box 230 (see FIG. 9J) can also be optionally selected by pressing the FLUSH station control button on the station control box 222 (see FIG. 9G). The solution flush box 230 includes touch buttons that prompt the operator to conduct a SHORT FLUSH (e.g., 2 seconds) or a LONG FLUSH (e.g., 5 seconds), during which time the compounding control manager 72 operates the corresponding peristaltic pump rotor assembly 54 for the selected pump station. The load cell 30 can also monitor for weight changes, indicating entry of solution into the final container 14, to verify (if desired) that flow communication exists between the source solution container 16 and the final container 14. The solution flush box 230 indicates completion of the flush (see FIG. 9K), and the operator is prompted to by an EXIT touch button to return to the main screen 202. Flush is not required prior to the start of compounding, but is available as an optional set up step.

[0128] The operator is prompted to follow the above prescribed sequence for each source solution and each pump station, until programming is complete. FIG. 9L shows the main screen 202 after (i) the operator has programmed the compounding control manager 72 to mix 137 mL of 70% dextrose (pump station 1), 54 mL of 15% novamine (pump station 2), 77 mL of 10% Travasol (pump station 3), and 216 mL of sterile water (pump station 9) from source solution

containers into the final container, and (ii) the operator has also verified for each pump station that the proper source solution and transfer tubing set up are present. As FIG. 9L shows, the main screen 202 lists the solutions and amounts in the respective fields 206 and 208 of each pump station box 204 and, further, prompts the operator to press a highlighted START touch button 232. Upon selection of the START touch button, compounding immediately commences under the control of the compounding control manager 72. If one or more of the source solutions have not been confirmed at the time the operator presses the START button 232, the compounding control manager 72 will automatically prompt the operator to confirm each remaining source solution before compounding is allowed to begin. The START touch button 232 is not enabled by the compounding control manager 72 until all required preliminary steps have been satisfactorily completed.

[0129] Alternatively, the operator can select an AUTO PGM touch button 234 on the main screen 202 (see FIG. 9L). This opens a queue selection screen 236 (FIG. 9P), which displays a list of preprogrammed schedule queues established by the system administrator. The operator selects the desired queue and presses the ENTER touch button on the queue selection screen 236. The compounding control manager 72 holds the order queue list in memory, and the main screen 202 (see FIG. 9Q) allows the operator to view the current order queue list, one order at a time, in a queue box 238. In this arrangement, the operator selects the order from the programmed order queue list on the main screen 202, and then starts compounding. Alternatively, the operator can scan a bar code on a final solution container to be compounded. The compounding control manager 72 uploads and presents the compounding order for that final container.

[0130] If, during the selection process outlined above, the operator programs a dextrose source solution and a Lipid source solution screen as part of the same compound with one immediately proceeding or following the other, the process recognizes this and displays screen 902 (FIG. 9G(1)) to the operator to avoid a situation whereby a breakdown (or cracking) of the lipid may occur without the introduction of the buffer solution. Also, and as it relates to additive solutions discussed below, a check whether calcium and/or phosphate are added to the final solution is conducted to avoid the formation of an insoluble precipitate. In the event that an improper concentration of these components is detected, the operator will be alerted with a display screen (not shown) similar to screen 902.

[0131] It may be the case that certain source solution are contained in small vials, rather than large bags or bottles. As such, these vials will necessarily have a small stopper end from which the solution will be extracted. Such a small stopper will limit the flow rate of the solution when compared to other types of source solution containers and may result in a flow rate that will fall below the normal flow rate that the system expects, thereby resulting in an alarm condition. To overcome this problem the system allows the operator to instruct the system through an appropriate screen selection that the source solution is being sourced from a vial or other reduced flow container. In response, the system will limit the upper speed on the pump when that particular source solution is pumped to avoid the false indication of reduced flow.

[0132] As compounding proceeds, the compounding control manager 72 updates the number TOTAL DELIVERED field 240 (by incrementing up) and amount field 208 (by

incrementing up) of the respective pump station field 204 of the main screen 202 (FIG. 9M), to indicate the series transfer of liquid from the several source containers 16 into the final container 14. In FIG. 9M, pump stations 1, 3, and 9 have been programmed. Station 1 has completed its pumping (having delivered the desired 138 mL). Station 3 has begun to pump (having pumped 38 mL). Station 9 is waiting to begin. The TOTAL DELIVERED field 240 shows 176 mL, which is the current sum of amounts pumped by pump stations 1, 2, and 3. The PUMPING icon 242 is illuminated to indicate that compounding is proceeding. The operator can, if desired, terminate compounding by pressing the illuminated STOP touch button 244.

[0133] If, during the course of compounding, the load cell 30 indicates that there is no liquid transfer into the final container 14, the compounding control manager 72 generates a pumping alarm. The compounding control manager 72 interrupts the compounding procedure when this alarm condition occurs. The compounding control manager 72 opens a pumping alarm screen 246 (FIG. 9N). The INTERRUPTED icon 248 is also illuminated to indicate that compounding is not proceeding. An information field 250 displays information pertaining to the alarm condition. The information field 250 prompts the operator to take corrective action and, by pressing a RESUME touch button 252, to commence compounding once again.

[0134] When compounding is complete, the compounding control manager 72 displays a COMPLETE message in the information field 250 (see FIG. 9O) and prompts the operator to remove the final container 14. In an alternate representation, once compounding is complete screen 910 (FIG. 9O(1)) is displayed. As shown in FIG. 9O(1), screen 910 includes patient name 912, the type of order 914, the amount ordered by volume (916) and/or weight (918), the amount of compound delivered by volume (920) and/or weight (922), and accuracy 924. The operator may close this screen by selecting "OK" 926 to continue.

[0135] The operator can then reprogram the compounding control manager 72 to carry out another compounding regime by following the above sequences of steps.

[0136] There are other graphical buttons on the main screen 202 (see FIG. 9B), which may be used to carry out various support functions. For example, by pressing the OPTIONS MENU touch button 214, the options menu screen (FIG. 9R) is displayed. The option menu screen prompts the operator to select among a list of administrative functions that, in the illustrated embodiment, include REPEAT LAST ORDER, ORDER HISTORY, SETTINGS AND DIAGNOSTICS, and SIGN OFF. Pressing the REPEAT LAST ORDER button automatically configures the compounding control manager to compound according to the most recent order. Pressing the ORDER HISTORY button displays an order history screen 258 (FIG. 9S), that lists the compounding orders that have been executed by the compounding control manager 72. These compounding orders are maintained in memory by the compounding control manager 72. Pressing the SETTINGS AND DIAGNOSTICS button displays the settings and diagnostic screen 260 (FIG. 9T) that displays additional administrative functions that the system administrator can perform, such as establishing the list of available source solutions for the solution programming box 212 (FIGS. 9D and 9E), previously discussed. Other additional administrative functions can also be accessed through this screen. Pressing the SIGN

OFF button displays a fresh log-in screen, and the compounding control manager 72 awaits a new order sequence from an operator.

[0137] In the illustrated embodiment, the main screen 202 also includes a CALIBRATE SCALE touch button 262 (see FIG. 9B). When pressed, the button 262 opens an instruction screen 270 (FIG. 9W), that leads the operator through a sequence of steps that calibrate the load cell. Alternatively, this function (CALIBRATE SCALE) may be provided within or as part of other screens (not shown) presented to the operator.

[0138] Also displayed on the main screen 202 is a HELP icon 264 (identified by a question mark—?). Pressing the HELP icon 264 on the main screen 202 opens a main screen help screen 266 (FIG. 9U), which displays a list of available help topics pertaining to the compounding control manager 72 and operation of the compounding device 18 in general. Desirably, a HELP icon 264 is also present on every other functional screen or box generated by the compounding control manager 72 (see, e.g., FIGS. 9A, 9E, 9H, 9P). Pressing the HELP icon 264 on any given screen opens a context sensitive help screen, which provides guidance pertaining to the particular function that the given screen performs. For example, FIG. 9V shows a context sensitive help screen 268 that opens when the HELP icon 264 on the pump alarm screen 246 (FIG. 9N) is pressed. As can be seen, the context specific help topic is NO SOLUTION FLOW ALARM, and the screen provides instructions for correcting the alarm condition.

[0139] In a desired implementation, the compounding control manager 72 incorporates within its preprogrammed structure an integrated selection of training and/or help video files, e.g., in MPEG format. The integrated training and/or help video files contain stored formatted video footage and streaming audio. When presented by the compounding control manager 72 on the display screen 76, the files communicate information to the operator in a direct visual and audible way. This platform of communication, which forms an integrated part of the compounding control manager 72, provides the operator direct, real time access to context specific information in an effective, first person, visual and audible format, eliminating the need to resort to offline training manuals or separate CD's.

[0140] In a representative implementation, pressing the HELP icon 264 on the main screen 202 opens a main screen video training/help screen 270 (FIG. 14A). The screen 270 displays a list of available training/help topics pertaining to the compounding control manager 72 and operation of the compounding device 18 in general. The screen incorporates 270 a MPEG viewing area 272, in which the training and/or help video files in the compounding control manager 72 are displayed. Selecting an instruction/help topic runs the associated MPEG file.

[0141] As an example, FIGS. 14B(1) to 14B(8) show representative screen captures from a training/help video for "Programming the Compounder." The training/help video, with associated streaming sound file, walk an operator through the steps of entering a compounding order using the graphical user interface of the compounding control manager 72. These steps have been previously described, with reference to FIGS. 9B to 9F. The training/help video explain that the first step is to identify the source solution (FIG. 14B(2)), and then proceed (FIG. 14B(3)), by visual and audible instructions, the procedure for using the Solution Program-

ming Box 212 (previously described in the context of FIGS. 9C and 9D). The training/help video then explain that the next step is to determine the solution volume (FIG. 14B(4)), and then proceed (FIGS. 14B(5) to 14B(7)), by visual and audible instructions, the procedure for using the Amount Programming Box 218 (previously described in the context of FIG. 9F). The training/help video concludes (FIG. 14B(8)) by congratulating the operator for successfully accomplishing the programming procedure.

[0142] As can by now be appreciated, the compounding control manager 72 serves to generate an interactive user interface that presents as much information/control on one screen as possible without making the screen too busy. Among its features are (i) to minimize user entry errors by making their entry points very focused and utilizing large display and keypad areas; (ii) to minimize keystrokes for the experienced user; (iii) to provide as much help as possible for the inexperienced user; and (iv) to minimize calls to service by making "smart help" available.

[0143] The compounding control manager 72 makes possible the operation of a gravimetric compounding device 18 under direct software process control, while utilizing barcodes as a process quality control mechanism.

[0144] Other useful features of the system include, for example, the activation of a process to freeze entry display screen 76 (or any other touch screen used to enter data and/or commands into the system). FIG. 16 illustrates this. As shown in FIG. 16, screen 1600 may be invoked as desired via a selection from the main system screen (not shown). Once activated, the display screen 76 is frozen and will not interpret tactile input on the display screen 76 as an attempt to enter data or otherwise instruct the system. In this way, the operator may clean the screen without jeopardizing an ongoing process or begin an unintended process, thereby avoiding waste of valuable source solutions and/or final solutions. The time that display screen 76 is frozen is preferably predetermined, such as 30 seconds, but may be adjustable if desired in a particular configuration.

[0145] Additionally, and as shown in FIG. 17, the process can also include screen 1700 that will advise the operator of items that need to be completed on that particular day. It is also possible to configure the checklist such that it advises the operator of items that span multiple days if desired.

[0146] B. The Order Entry Process Manager

[0147] The order entry process manager 84 can be installed on the MPU 58 of the controller 20 and/or on another workstation linked to the controller 20. The order entry process manager 84 provides an array of enhanced order entry functions for the compounding control manager 72. The order entry process manager 84 also provides an information management function and label printing function, that make possible simplified and consolidated order data record storage and control on a patient-by-patient basis. This function is integrated with the communication of the order data to the compounding control manager 72 of a compounding device 18, to thereby facilitate set-up, operation, and management of an overall compounding system in a reliable fashion that minimizes error. The order entry process manager 84 makes possible a centralized or distributed order data entry, order data storage, order data manipulation, and order data communication system.

[0148] The order entry process manager 84 desirably receives data input through keyboard/mouse devices 78, and provides data output either through the display screen 76 of

the control panel 24 (as shown in FIG. 8A), or a separate, dedicated display device 376 (as shown in FIGS. 8B to 8F). The order entry process manager 84 also is desirably linked to a printer 302 (or 80), for providing reports and labeling in paper form.

[0149] The order entry process manager 84 can be developed to generate its own proprietary user interface (like the compounding control manager 72). Desirably, however, the order entry process manager 84 is developed in a graphics-based environment (e.g., Windows.®, Linux.®, etc.) using, e.g., an Apache.® or Java.® Operating Environment that can be used in association with conventional web-server or browser software 86, such as Microsoft.® Internet Explorer, Netscape.® Navigator, or an equivalent public accessible browser. In this arrangement, the order entry process manager 84 desirably comprises the program language that provides the operator with real time feedback and interaction with the controller 20 of the compounding device through browser-based graphic user interface (GUI) elements. The browser-based GUI elements allow an operator to input and adjust the information used by the compounding control manager 72 to operate the compounding device. This makes possible the linkage of the proprietary compounding control manager 72 of the compounding device to one, several, or an entire network of conventional browser data entry and output platforms, which can comprise a single local site or a network of remote sites. Implemented in this manner, the order entry process manager 84 and browser software 86 make fully networked compounding possible. Furthermore, the order entry process manager 84 makes possible a network appliance function, whereby all an authorized operator has to do is couple a browser to the MPU 58 of the compounding device 18 to be able to control the compounding device 18. The network appliance function significantly enhances the usability and flexibility of the compounding device 18.

[0150] To develop the browser-based GUI elements, the order entry process manager 84 utilizes certain third party, off-the-shelf components and tools, available in e.g., Apache.® or Java.® Operating Environments. Once developed, the order entry process manager 84 can reside as a software program on a memory device. The order entry process manager 84 can be accessed by a laptop or desktop workstation computer, PDA device, or any other device that can run a browser, to provide different order entry platforms.

[0151] C. Associations with the Compounding Control Manager

[0152] The order entry process manager 84 and browser software 86 accommodate diversely different associations with the compounding control manager 72 installed on the controller 20 of the compounding device 18.

[0153] In a basic form (see FIG. 8A), the order entry process manager 84 and browser software can be installed in the MPU 58 in the control panel 24 of the compounding device 18, to constitute a single control panel configuration. In this arrangement, the display device 76 on the control panel 24 supports the browser-based interface of the order entry process manager 84 for order entry to the compounding device and label printing, as well as supporting the proprietary touch screen interface of the compounding control manager 72 during operation of the compounding device.

[0154] In another arrangement (see FIG. 8B), the browser software 86 can be installed on a data entry workstation 304 positioned in the same facility as the compounding device 18. The data entry workstation 304 can be placed near the com-

pounding device 18, or it can be physically separated from the compounding device within the facility. In this arrangement, the browser software 86 of the data entry workstation 304 is linked, e.g., via a hubless local area network connection to the order entry process manager 84 residing in the MPU 58 in the control panel 24 of the compounding device 18, to constitute a single data entry station configuration. In this arrangement, the display device 376 of the data entry workstation 304 supports the browser-based interface of the order entry process manager 84 for order entry to the compounding device and label printing. The display device 76 of the control panel 24 supports the proprietary touch screen interface of the compounding control manager 72 during operation of the compounding device 18.

[0155] In another arrangement (see FIG. 8C), the browser software 86 can be installed on several data entry workstations 304 positioned in the same facility as the compounding device 18. The browser software 86 of the data entry workstations 304 can be linked, e.g., via a hub 306 or switch as a local area network to the order entry process manager 84 residing in the MPU 58 in the control panel 24 of the compounding device 18, to constitute a multiple data entry station configuration. In this arrangement, the display device 376 of each data entry workstation 304 supports the browser-based interface of the order entry process manager 84 for order entry to the compounding device 18 and label printing by the printer 302. A single compounding device 18 can thereby be linked to several order entry workstations 304. The display device 76 on the control panel 24 of the compounding device 18 supports the proprietary touch screen interface of the compounding control manager 72 during operation of the compounding device.

[0156] In another arrangement (see FIG. 8D), the browser software 86 can be installed on several data entry workstations 304 positioned in the same facility as several compounding devices 18. The browser software 86 of the data entry workstations 304 can be linked, e.g., via a server 308 to form an intranet facility network 310, and the order entry process manager 84 residing in the MPU's 58 in the control panels 24 of the several compounding devices 18 can be linked to the server 308 via a hub 312, to constitute a fully networked data entry, multiple compounding station configuration. In this arrangement, the display device 300 of each data entry workstation 304 supports the browser-based interface of the order entry process manager 84 for order entry to the compounding device 18 and label printing by the printer 302. Multiple compounding devices 18 can thereby be linked to multiple order entry workstations 304. The display device 76 in the control panel 24 of each compounding device 18 supports the proprietary touch screen interface of the compounding control manager 72 during operation of the respective compounding device. As shown in FIG. 8D, the browser software can be installed in a PDA device 314; or any other device that can run a browser, to provide different order entry platforms.

[0157] In another arrangement (see FIG. 8E), the browser software 86 can be installed on one or more data entry workstations 304 positioned in a data entry facility 316 that is remote to another facility 318 where one or more compounding devices 18 are located. The browser software 86 on one or more data entry workstations 304 at the remote data entry facility 316 can be linked to the order entry process manager 84 residing in the MPU(s) 58 in the control panel(s) 24 of the compounding device(s) 18 at the remote compounding facil-

ity 318 via the public internet 320. Of course, other forms of remote linkage can be used. The browser software 56 can be installed, alone or with the installation on the remote workstations 304, on one or more data entry workstations 304 at the local compounding facility 318, and also linked to the order entry process manager 84 in the MPU(s) 58 in the control panel(s) 24 of the compounding device(s) 18 via the public internet 320. If the facilities 316 and 318 are part of a common operating entity, the order entry process manager 84 and browser software 56 can be installed on a data collection/administration workstation 304 positioned in a data center facility 322 that is remote to both the data entry and compounding facilities 316 and 322. The data center 322 maintains an information data base 324 of patient information and compounding resources for the compounding facility 318, and also be linked to the data entry facility 316 and the compounding facility 318 via the public internet 320.

[0158] In a variation to the arrangement shown in FIG. 8E (see FIG. 8F), a host data entry service facility 326, where the order entry process manager 84 is installed, can be coupled via the public internet 320 to one or more remote data entry facilities 328A, 328B, 328C, 328D. The host data entry service facility 326 can also be linked via a virtual private network 328 through the public internet to a remote compounding facility 330, where the compounding control manager 72 is installed in the MPU 58 in the control panel 24 of the compounding device 18. The browser software 86 is installed on the data entry workstations 304 positioned in the remote data entry facilities 328A to 328D. The host data entry service facility 326 maintains the data collection and management data base 332 for the entire network. In this way, multiple order entry facilities 328A to 328D can be linked to a single compounding facility 330 via an intermediary service facility 326, which can also maintain a central collection and management data base 332.

[0159] B. Features of the Order Entry Process Manager

[0160] FIG. 10A(1) shows a general schematic representation of the operator-selectable functional modules that a representative implementation of the order entry process manager 84 can possess. As illustrated, these functional modules include a prescription order module 400, a source solution module 402, a reports module 404, an administration module 406, and a navigation module 408. The prescription order module 400 allows an operator to enter a prescription order for a given patient, with reference to a preexisting compound formula or to a new compound formula, as well as schedule the order for compounding. The source solution module 402 maintains an inventory of available base source solutions and additive source solutions that are cross-referenced in the formula library of the prescription order module 400. The reports module 404 provides an operator the capability of tracking compounding activities and generating various administrative reports relating to these activities. The administration module 406 aids the operator in the performance of various administration tasks in support of the compounding activity. The navigation module 408 assists the operator in use of the order entry process manager 84. Each module contains one or more functional components that an operator can select in using the module, as will be described in greater detail later.

[0161] FIGS. 10A(2)-10A(6) illustrate a flow chart of the logon sequence and the level of access given to various users, such as the administrator (FIG. 10A(3)), Pharmacist (FIG. 10A(4)), Technician (FIG. 10A(5)), and Guest (FIG. 10A(6)),

for example. As shown in FIG. 10A(2), the administrator has the highest level of access and can ultimately control access by any other user. The administrator can also create additional classes of users as well as subclasses within any class of users. For example, although technicians are given very restricted rights within the system to formulate compounds for instance, it may be that there are certain technicians that require less oversight and can thus be granted greater privileges.

[0162] A given operator can gain access to one or more of these functional modules, depending upon the access options that the system administrator grants a given operator, which depends upon the functions that the operator is required to perform. For example, a hierarchy of access options can be specified for use by a physician or pharmacist, who specifies or enters compounding orders; a compounding activity administrator, whose function is to oversee the compounding function from an administrative standpoint; and a compounding technician, whose function is to operate one or more compounding devices 18. The available functional modules can be displayed as menu box selections on a main screen or home page, which opens once a given operator identifies itself by name and assigned password on an appropriate log-on screen.

[0163] For example, FIG. 11A shows a representative main screen or home page 410 for an operator who has a physician or pharmacist access option. As FIG. 11A shows, all functional modules 400 to 408 are available for selection at this access level, because performance of that person's function may require access to all features of the order entry process manager 84. As a comparative example, FIG. 11B shows a representative main screen or home page 410' for a compounding technician, which offers access to a lesser selection of functional modules, because the technician's function does not require access to all the functional features of the order entry process manager 84. The functional module menu boxes which a given individual may access may appear in a column along the left side of other screens generated by the order entry process manager 84.

[0164] Assuming that the operator is at a physician or pharmacist access level, and is thereby viewing the home page shown in FIG. 11A, the operator can, with a mouse click, select a desired functional module. Assuming the operator seeks to enter a prescription order for a given patient, the operator mouse-clicks on the Patients component of the PRESCRIPTION ORDER menu box 400, which opens the PATIENT MAIN PAGE 412 shown on FIG. 11C. This window 412 provides access to the features of the Patient Data Base Component 414 of the order entry process manager 84, the functional units of which are shown schematically in FIG. 10B.

[0165] The Patient Data Base Component 414 allows a user to either select an existing patient by a last name search of a list of patient information files created in a patient information data base maintained by the order entry process manager 84 (FIND A PATIENT box field 416), or by entering the name of a new patient (ENTER NEW PATIENT box field 418).

[0166] Upon finding an existing patient's name, the order entry process manager 84 provides a window displaying the contents of the corresponding Patient Information Record 420 (FIG. 11D). The Patient Information Record 420 allows the operator to enter a new compounding order, based upon previous compounding orders retained in the patient data base for that patient (TPN ORDERS ON FILE FOR PATIENT box field 422), or allows the operator to enter a new compounding

order for that patient based upon a standard default templates for a patient type that the patient matches (NEW TPN ORDER TEMPLATES AVAILABLE FOR STANDARD ADULT PATIENT TYPE box field 424). The operator can also review an existing nutritional assessment or start a new nutritional assessment as desired. Nutritional assessments are discussed in detail below with respect to FIG. 19.

[0167] The PRESCRIPTION ORDER MENU box 400 includes a Formula Library component. When selected, the Formula Library component provides access to the features of the Formula Library Data Base Component 426 of the order entry process manager 84, the functional units of which are shown schematically in FIG. 10C. Selection of the Formula Library component opens a Formula Library web page 420 shown in FIG. 11F(1). The Formula Library web page 420 permits the operator to select an existing default formula template for display and selection in the Patient Information Record page 424, or to add a new formula template for display in the Patient Information Record. Selection of template opens a scrollable Order Template web page 434 shown in FIGS. 11F(2), 11F(3), and 11F(4), that allows the operator to specify base components (types and amounts) and additive solutions (types and amounts) for a template formula. Default data in an existing template formula can also be changed and submitted. The Order entry process manager 84 computes the nutritional requirements of the template formula based upon the selected types and amounts of base components and additives, drawing upon data contained in the source solutions module 402, as will be described in greater detail later.

[0168] A mouse click selecting one of the order options 422 or 424 on the Patient information Record opens a scrollable Order Entry window 436 (FIGS. 11E(1) to 11E(4)). The Order Entry window 436 includes field boxes that contain details of the PRESCRIPTION ORDER (box 438), the BASE COMPONENTS included in the order (type and amount) (box 440), the ADDITIVES included in the order (type and amount) (box 442), the NUTRITIONAL SUMMARY (based upon the types and amounts of the base components and additives included in the order) (box 444), and the ORDER STATUS (which will be described later) (box 422). The default listing of solutions and solution amounts in the BASE COMPONENTS and ADDITIVE field boxes 440 and 442 are provided based upon the selection on the Patient Information Record 420—to base the order upon a previous order or a standard template. The default BASE COMPONENTS and ADDITIVES can be edited to change the previous order or template type and/or amount, or they can be submitted without change. The Order entry process manager 84 computes the NUTRITIONAL REQUIREMENTS (box 444) based upon the selected types and amounts of base components and additives, drawing upon data contained in the source solutions module 402.

[0169] It is also important that medical personnel be able to perform a nutritional assessment of the patient. That is, to make determinations of patient nutritional needs and compare those needs to the orders for the patient. As such, when the operator makes a selection in section 423 of the patient's record (see screen 420 shown in FIG. 11D for example) he is provided with the Nutritional Assessment Screen 1900 (FIG. 19). The selection in screen 420 may be either to review an existing assessment or to perform a new assessment. Screen 1900 is divided into three sections, Patient Demographic Information 1902; Patient Assessment Information 1904; and Calculated Nutritional Requirements 1906.

[0170] The Patient Demographic Information Section 1902 includes certain demographic information concerning the selected patient and may include for example, Patient Name; Patient ID; Patient Age; Patient Sex; Patient Height; Patient Weight; Location of the Patient; Diagnosis; Physician; Allergies; and a Picture of the Patient.

[0171] The Assessment Section 1904 includes a brief patient descriptor composed of the patient's sex, age, and height. The screen desirably includes a Date/Time stamp for when the assessment was last updated. The Assessment Section 1904 also includes various input fields, such as a Text Box for the Assessment Title; a Numeric Text Box for Patient Weight in the local units (default value—weight in patient demographic data); a Pull-down List of Injury Factors, including for example, Low (uncomplicated, general surgery) (default); Moderate (complicated, extensive surgery); High (sepsis, burns); a Pull-down List of Stress Factors, such as Mild, Moderate, Severe, Renal Dysfunctional/Dialysis, and Renal Dysfunctional/Non-Dialysis.

[0172] The Assessment Section 1904 also includes two buttons 1905, 1907. When selected, the "Update Assessment" Button 1905 takes the information on the screen and uses it to calculate the nutritional requirements which will be presented in the Calculated Nutritional Requirements section and also updates the Assessment's Date/Time Stamp. If this is a new assessment, a Cancel Button is provided, that if selected will abort the assessment creation and return to the previous screen. If this is an existing assessment, a Delete Assessment Button 1907 can be used to remove the assessment from the list of assessments associated with the patient.

[0173] The Calculated Nutritional Requirements Section 1906 desirably provides the following information preferably calculated to two decimal places based on the patient information provided in the Patient Assessment Section 1904, such as Ideal Body Weight; Condition Assessment; Adjusted Body Weight; Basal Energy Expenditure in Kcal/Day; Total Protein Requirements in gm/Day & gm/Kg/Day; Total Calories Requirement in Kcal/Day & Kcal/Kg/Day; and Fluid Requirement Range in mL/Day.

[0174] The Calculated Nutritional Requirements Section 1906 desirably provides a link 1908 to allow the user to compare the current nutritional assessment to existing orders for the patient. When exercised, a Nutritional Assessment Comparison Order Selection Screen appears.

[0175] The Calculated Nutritional Requirements Section 1906 also desirably provides a link 1909 to allow the user to enter a TPN order based on the current nutritional assessment. When selected, the TPN Order Screen (see FIG. 20) is provided with the fields populated based on the current patient and the nutritional needs of the patient. When the operator is finished with this screen he activates the "Done" button 1910 to return to the calling screen. It is also contemplated that alternative or customized nutritional assessment calculations may be included as part of the exemplary system.

[0176] The operator can open the Order Entry window (FIGS. 11E(1)) to 11E(4)) to enter a compounding order for a new patient (i.e., a patient not previously entered into the patient data base) by selecting ENTER A NEW PATIENT field box 418 on the Patient Main Web Page 412 (FIG. 1C). With this selection, the order entry process manager 84 opens a window displaying a New Patient web form 448 (FIGS. 11G(1) and 11G(2)), prompting the operator to enter data pertaining to the new patient. Upon entry of the new patient information, the operator saves the information to the patient

data base (selecting the UPDATE field box **450**—shown in FIG. **11G(2)**), at which time the scrollable Order Entry window **436** opens for entry of the compounding order (FIGS. **11E(1)** to **11E(4)**).

[**0177**] The next screen of the Order Entry window **436** (FIG. **11E(4)**) includes an ORDER STATUS box **422**. The ORDER STATUS box **422** comprises a listing of the functional steps in a compounding operation that must be executed between order entry and delivery of the compounded order to a patient. The ORDER STATUS box **422** also colors or highlights the steps to indicate which steps have been performed and which remain to be performed. The ORDER STATUS box **422** provides a check list of functions that must be performed to carry out the compounding process and, at a glance, informs an operator what function has been performed and what function still needs to be performed. In the illustrated embodiment (FIG. **11E(4)**) the function steps listed include OPEN, SUBMITTED, AUTHORIZED, PRINTED, and COMPOUNDED.

[**0178**] The OPEN step entails the opening of the Order Entry window **436**, and the entry of information making up the compounding order. In FIG. **11E(4)**, the OPEN icon **452** is colored or highlighted, to indicate that this step has been accomplished.

[**0179**] As part of the order entry, a Final Container is automatically selected based on an inventory of available final containers. This list is desirably prepared by the system administrator or other individual having such rights. Set up of the inventory is illustrated in FIG. **11E(5)**. As shown in FIG. **11E(5)**, upon selection of the final container line item **492** of the Inventory Configuration module **490** of the order entry process manager **84** a list **491** of available final containers is displayed. Through this screen, the administrator may review the listing of available containers, and if necessary delete a container no longer in stock, if desired.

[**0180**] In normal operation, a final container conforming to the volume of the final solution ordered will be automatically selected. Alternatively, through a manual operation the operator may select a final container presented through a list which may be similar to that of FIG. **11E(5)**. In the event that the operator selects a final container that is too small of the final solution, an error indication will be provided and the operator will be instructed to make an alternate selection.

[**0181**] If the administrator needs to add a new container to the inventory this may be accomplished by selecting “Add a New Final Container” selection **494**, whereupon screen **493** (FIG. **11E(6)**) is presented to the operator. As shown in FIG. **11E(6)**, the administrator has the capability to enter a description for the new container, as well as particulars of the container, such as rated size, maximum capacity, nominal empty weight, maximum under normal weight, maximum over normal weight and unit cost. If the administrator decides to save the information into the inventory, he selects “Update,” otherwise, the administrator can delete the record to start over again, or select “Cancel” to exit this screen without changing the inventory configuration. The data regarding the final containers is also available for access via the compounder control panel screen.

[**0182**] Although the majority of the final solution is comprised of portions of various source solutions, there are other components that may be necessary to complete the particular patient’s nutritional needs. For example, there are various additive solutions, such as electrolytes, vitamins, minerals, etc. that may need to be included based on the patient’s

nutritional assessment. In many cases, these individual additives may need to be added in such minute amounts that automated macro-compounding is not useful. To overcome this, it is possible to “pool” the various additive solutions into a pooled additive bag to be used as another source solution for use during the compounding process. For example, if a patient is to receive as part of his daily compounded solution 1 mL of a vitamin, 2 mL of sodium chloride, and 3 mL of potassium phosphate each day over a ten day period, a pooled solution consisting of 10 mL of the vitamin, 20 mL of sodium chloride, and 30 mL of potassium phosphate may be compounded with the present invention to create a 60 mL source solution. Then, when the daily final solutions need to be compounded, this additive source solution may be included and selected to provide 6 mL of the pooled solution. The details related to this are described below.

[**0183**] TPN Order Entry Screen **2100** (FIG. **21A**) desirably provides the Patient Name, Patient ID and Order ID (if linked to from the TPN Order Entry Screen) or the Formula Template name of which the Base Component Solution is a component (if linked to from the TPN Order Template Screen). As part of the Screen **2100**, a prescription order section **2102** is provided. Within section **2102** is a “Batch Copies” entry **2103** which is used to prepare multiples of a particular order. In this example, seven (7) identical batches are to be prepared. In addition, screen **2100** includes section **2104** relating to Additives to be used in the order. Section **2104** desirably presents for example the name of the Additive Solution in the selected color, the amount ordered and ordering units in the current formula, Dose Amount; a pull down for Dose Order Units with a default unit of measure (based on the unit in the database entry for the selected additive); Per Amount unit; mL (default); Lb; 500 mL; 100 Lb; 250 mL; 100 mL; Kg; 100 Kg; Liter; Kg-mL; Kg-l; Lb-mL; Lb-l.

[**0184**] If these additives are selected to be part of the active pooling inventory (see FIG. **21B**), upon the user selecting Pool Additives **2111** and then activating the “Submit Changes” button, the system will automatically create a pooled additive solution. Upon completion of the pooled additive solution, the system will identify the pooled additive solution with an identifier desirably including the patient’s name and a bar code identifier. This pooled additive will now be considered as another source solution for compounding and added to Base Compounds section **2108** of screen **2100**.

[**0185**] Section **2104** also provides access to the additive source inventory screen **2120** (FIG. **21B**) by selecting the Edit detail link **2110**. Depending on the user’s permission level, the user may review the details of a particular additive or edit those details. Of significance to the pooling function is the “Additive Pooling” selection **2122**. If an additive is allowed to be part of the pooling process the “Allow” selection is enabled, otherwise, the “disallow” selection is enabled.

[**0186**] User screen control options include for example, a button to Submit (“Update”) the changes, thereby updating the individual order/order template; a button to Return (“Cancel”) without making any changes, and a “Delete” function to delete this particular additive from the inventor (assuming the required permission level). Desirably, the screen provides the following exemplary information regarding the current additive solution from the database: Name of the Additive Solution; Concentration; Specific Gravity; Osmolarity—mOsm/L; Cost—Localized Current Value/mL; and Electrolyte Content Details.

[0187] The SUBMITTED step entails mouse-clicking the DONE button, which places the information in the database and thereby makes the Order Entry window containing the pending compounding order available for viewing on any workstation with a proper operator access level, which, in this case, would be a designated authorizing pharmacist. The SUBMITTED icon 454 is colored or highlighted on the Order Entry window 436 when the step has been completed. The order entry process manager 84 desirably keeps track in the database of the compounding orders submitted by the various order entry workstations that are awaiting authorization, so that they can be accessed in an organized fashion by the browser software at the workstation of the authorizing pharmacist. The authorizing pharmacist knows to periodically run the browser software to access this queue of pending orders, to review each pending order, and indicate authorization of each order in the AUTHORIZE THIS ORDER FOR COMPOUNDING field box 456 on the Order Entry window 436.

[0188] In another arrangement, the order entry process manager 84 can include a notification function, which provides a pop-up message at the workstation of the authorizing pharmacist to alert the individual that there are entered compounding orders awaiting authorization. Clicking on the pop-up message opens a list of the orders awaiting authorization that the authorizing pharmacist can access.

[0189] In the illustrated embodiment, authorization entails clicking the authorization statement (box 458), selecting the shift in which the compounding is to be performed (box 460), and selecting the AUTHORIZE FOR COMPOUNDING icon 462. A STAT ORDER icon 464 is provided if the compounding order is to be performed as soon as possible. The AUTHORIZED icon 466 is colored or highlighted on the Order Entry window 436 when the authorization step has been completed.

[0190] The order entry process manager 84 desirably keeps track of the compounding orders that are in the database that have been authorized and are awaiting the printing of labeling, so that this subset of orders can be accessed in an organized fashion at a workstation where printing occurs. These compounding orders are accessed at the workstation where labeling for the final solution container 14 is to be printed.

[0191] In another arrangement, the order entry process manager 84 can include a notification function, which provides a pop-up message at the workstation where printing occurs to alert the operator that there are authorized compounding orders awaiting printing. Clicking on the pop-up message opens a list of the orders awaiting label printing that the operator can access to perform the printing function.

[0192] The order entry process manager 84 formats the labeling (see FIG. 12) based upon the information entered in the Order Entry window 436. The labeling includes a label 470 for the final solution container 14, a worksheet 468 identifying the source solutions and targeted compounding volumes, a worksheet 472 providing nutritional information for the contents of the final solution container 14, and a label 474 for a piggyback container, if ordered. The labeling also includes the bar codes 476 that the compounding control manager 72 requires to verify the compounding order and perform the actual compounding process. The final container bar code 476 (on the final solution container label 470) can also be used to electronically transfer formula information after compounding to a capable medication dispensing device (e.g., such as an infusion pump).

[0193] Upon completion of the printing step, the compounding order is made available for electronic transfer to a

compounding control manager 72 of a compounding device 18. The PRINTED icon 478 is colored or highlighted on the Order Entry window 436 when the labeling printing step has been completed and the order has been made available for transfer to the compounding control manager 72 for completion.

[0194] In the networked compounding environment that the order entry process manager 84 makes possible, when it is time to compound, the compounding clinician at the compounding station logs into the compounding control manager 72 and selects the AUTO PGM touch button 234 on the main screen 202 generated by the compounding control manager 72 (see FIG. 9B). This opens a queue selection screen 236 (FIG. 9P), which displays a list of preprogrammed schedule queues that have been established by the previously described order entry and processing steps, as controlled by the order entry process manager 84. The operator selects the desired queue (based upon the present compounding shift—e.g., morning or afternoon) and presses the ENTER touch button on the queue selection screen 236. The compounding control manager 72 holds the order queue list it receives from the order entry process manager 84 in memory, and the main screen 202 (see FIG. 9Q) thereafter allows the operator to view the current order queue list in the window 238. In this arrangement, the operator selects the order from the programmed order queue list 238 on the main screen 202, and then, as prompted by the compounding control manager 72, proceeds to connect the final solution container 14 to the manifold 36, perform the source solution and final solution verifications, perform the flushing sequences (if necessary), and starts compounding in the manner previously described.

[0195] As previously described, the use of bar code data in the verification function of the compounding control manager 72 necessitates that the labeling (FIG. 12) that is generated by the order entry process manager 84 must be available to and used by the compounding clinician in order to operate the compounding device and complete the compounding order. This integrates the submission, authorization, and printing functions of the order entry process manager 84 with the control functions of the compounding control manager 72.

[0196] The compounding control manager 72 communicates with the order entry process manager 84 when the compounding process has been completed, the COMPOUNDED icon 480 on the Order Entry window is colored or highlighted accordingly.

[0197] The order entry process manager 84 can provide other functions that can be accessed through the PRESCRIPTION ORDERS menu box. For example, as shown in FIG. 11A, a Schedules component can be included that allows the operator to view and alter the scheduling of compounding orders by shifts.

[0198] On the home screen shown in FIG. 11A, the operator can, with a mouse click, select other functional modules of the order entry process manager 84. If, for example, the operator seeks to view the inventory of base components maintained by the compounding facility, the operator mouse-clicks on the Base Components function of the SOURCE SOLUTIONS menu box 402, which opens the BASE COMPONENTS MAIN PAGE 482 shown on FIG. 11H(1). This window provides access to the features of the Base Solutions Data Base Component 428 of the order entry process manager 84, the functional units of which are shown schematically in FIG. 10D.

[0199] When selected, the BASE COMPONENTS MAIN PAGE 482 (FIG. 11H(1)) permits the operator to select a base component maintained in the existing facility inventory, or to add a base component to the inventory. Selection of a base component opens a scrollable Base Component Inventory Page 484 pertaining to the selected component, as shown in FIGS. 11H(2) and 11H(3). The Base Component Inventory Page 484 allows entry and retention by the order entry process manager 84 of pertinent information pertaining to the selected base component—e.g., its name; family type (Amino Acid, Dextrose, Fat Emulsion, etc.); concentration; specific gravity; cost per 100 mL; the choice of the pump rotor assembly of the compounding device to convey the component; NDC lot number; expiration date; electrolyte content, nutritional content, and other information.

[0200] Similarly, if the operator seeks to access the inventory of additive solutions maintained by the compounding facility, the operator mouse-clicks on the Additive Solutions function of the SOURCE SOLUTIONS menu box 402, which opens the ADDITIVE SOLUTIONS MAIN PAGE 486 shown on FIG. 11I(1). This window provides access to the features of the Additive Solutions Data Base Component 430 of the order entry process manager 84, the functional units of which are shown schematically in FIG. 10E.

[0201] When selected, the ADDITIVE SOLUTIONS MAIN PAGE 486 (FIG. 11I(1)) permits the operator to select an additive solution maintained in the existing facility inventory, or to add an additive solution to the inventory. Selection of an additive solution opens a scrollable Additive Solution Inventory Page 486 pertaining to the selected additive solution, as shown in FIGS. 11I(2) and 11I(3). The Additive Solution Inventory Page 486 allows entry and retention by the order entry process manager 84 of pertinent information pertaining to the selected additive solution—e.g., its solution type; its patient type; concentration; specific gravity; cost per mL; the choice of the pump rotor assembly of the compounding device to convey the component; NDC lot number; expiration date; electrolyte content; and other information.

[0202] The Base Solutions Data Base Component 428 and the Additive Solutions Data Base Component 430 of the order entry process manager 84 store pertinent information, for cross-reference by the other functional modules of the order entry process manager 84. For example, the Formula Library 426 draws upon information stored in the Base Solutions Data Base 428 and the Additive Solutions Data Base 430 to fill out the default information in the formula templates. Thus, library solutions can be restricted by patient type. As another example, the nutritional information derived by the order entry process manager 84 contained in the printed labeling (label 472 in FIG. 12) is drawn from information stored in the Base Solutions Data Base 428. Administration reports (to be described later) derive inventory, use, and cost management information based upon information stored in the Base Solutions Data Base 428 and the Additive Solutions Data Base 430.

[0203] From the home page shown in FIG. 11A, the operator can, with a mouse click, select to access the report module 404. The operator can select among a list of report selections contained in the REPORTS menu box 404. The reports module 404 provides an operator the capability of tracking compounding activities and generating various administrative reports relating to these activities. The nature and format of the reports can, of course, vary according to the particular requirements of the compounding facility. The reports mod-

ule 404 can generate reports that, for example, (i) list the compounding orders entered during a prescribed reporting period (arranged, e.g., by patient, date, time, entry operator, and the like); or (ii) list the compounding orders that were compounded during a prescribed reporting period (arranged, e.g., by compounding device number, date, time, compounding clinician, patient, final container number, time elapsed, and the like); or (iii) list source solution usage in liters during a prescribed reporting period arranged, e.g., by solution type, day, month, cost, and/or lot numbers, and the like; or (iv) list customer billing records for completed compounded containers, including, e.g., costs per mL of compounded fluid by solution type, flat rates costs by container or solution type, labor costs by machine compounding hours, flat labor costs, or a combination of any of these; or (v) list a log of operators accessing the order entry processing manager, arranged, e.g., by date, time, operator name, and event. Any or all of these reports can be generated by the reports module 404 of the order entry process manager 84 according to preformatted templates, or by customized or relational field searches of data bases maintained by the order entry process manager 84. The reports module 404 desirably includes the capability of formatting the reports for printing in hard copy format, or offloading the reports in electronic file format, e.g., in PDF file format.

[0204] From the home page shown in FIG. 11A, the operator can, with a mouse click, select to access the administration module 406. The operator can select among a list of administration options contained in the ADMINISTRATION menu box 406. The administration module aids the operator, who is in this instance typically the compounding activity administrator or supervisor, in the performance of various administration tasks in support of the compounding activity.

[0205] The nature of the administrative functions supported by the administration module 406 can, of course, vary according to the particular requirements of the compounding facility. The administration module 406, for example, can allow the administrator to add, delete or modify the schedule of shifts during which compounding takes place—which, in turn, becomes viewable (box 460) in the Order Entry web page (FIG. 11E(4)), for selection by the authorizing pharmacist during the order authorization process. The administration module 406, as another example, can allow the administrator to add, delete or modify the inventory list of compounding devices maintained by the compounding facility—which information, in turn, becomes available for use in the compounding reports generated by the reports module 404. The administration module 406, as another example, can allow the administrator to add, delete or modify the categories of patient types (e.g., standard adult; standard neonate; standard pediatric) accounted for by the compounding facility—which, in turn, can be linked to the patient information data base and can also be linked to the formula template data base 426 maintained by the order entry process manager 84 (i.e., a standard adult formula template can be linked to a standard adult patient type, to facilitate the compound order entry process). The administration module 406, as another example, can allow the administrator to add, delete or modify the list of operators by name or by operator groups (e.g., administrative staff, pharmacy staff, pharmacy technician, supervisor) that are permitted access to the order entry process manager 84, as well as assign passwords and access rights particular to each operator and each operator group. In this respect, operator's rights and restrictions can be tailored

for that operator individually, and not as part of an overall group (e.g., as a technician or a pharmacist). Groups can also be prohibited or allowed access to certain patient types (e.g., Dr. Brown cannot see information pertaining to Dr. Smith's patients).

[0206] An example of how physicians can be added is described with reference to FIGS. 20A and 20B. Within administration module 406 is a selection Individual Physicians 407, which upon selection provides screen 2000 (FIG. 20A) to the user including physician list 2002. If a physician needs to be added to the list, the operator selects link 2002 which brings up physician information screen 2006 (FIG. 20B). The Physician Information screen 2006 includes certain information concerning the physician which desirably includes for example, Login ID; A facility pull down to limit the facilities in which this physician has privileges; Name; Title; Address; Office Telephone Number; Mobil Telephone; Pager Number; Facsimile Number; email address; additional contact information; Federal Physician ID; and after hours service number. The Physician Information screen 2006 also includes two buttons 2007, 2008. When selected, the "Update" Button 2007 takes the information on the screen and saves it into the Physician database. When selected, the Cancel Button will abort the present screen and return to the previous screen without updating the Physician database.

[0207] On the home page shown in FIG. 11A, selection among the options provided by the navigation module 408 of the order entry process manager 84 can provide a short cut to the operator's home page, a help function, a general data base search function outside of the order entry, report, or administration functions, and/or a user log-out function. Selective use of operator access rights allows for patient record privacy in compliance with governmental HIPAA regulations.

[0208] As can be by now be appreciated, the order entry process manager 84 and browser software provide a physician or compounding order facility the capability to electronically transfer compounding requirements to a compounding facility via direct wire, network, or internet based systems. The order entry process manager 84 and browser software provides a compounding facility the capability to electronically enter compounding requirements on site or to receive electronically generated customer compounding requirements from remote sites. The order entry process manager 84 and browser software provide a compounding facility the capability to queue multiple customer compounding requirements into an efficient compounding and delivery schedule. The order entry process manager 84 and browser software provide a compounding facility the capability to generate container labels, including bar codes, as well as control the actual compounding process. The order entry process manager 84 and browser software provides a compounding facility the capability to automatically generate customer billing and inventory control for completed compounded containers. Billing options can include costs per mL of compounded fluid by solution type, flat rates costs by bag or solution type, labor costs by machine compounding hours, flat labor costs, or a combination of any of these.

[0209] A Daily Checklist which is derived from screen 500 (FIG. 11J(1)-11J(2)) is desirably displayed upon log on of the operator at the control panel. Items on the checklist may be added or rearranged as necessary or desired. It is desirable that all active items be displayed. If an item is indicated as being complete, the date/time and ID of the operator will be

entered into the log. Required items must be completed before compounding is allowed to occur.

[0210] As shown in FIG. 18A, upon selecting the Infusion Pump line item 495 of the Inventory Configuration module 490 of the order entry process manager 84 a list 496 of available infusion pumps is displayed. The infusion pump is the device that is used to deliver the final solution prepared by the compounder to the patient. Through this screen, any one of the available infusion pumps may be selected for use as the means to deliver the final solution to the patient. Once an infusion pump is selected, ramp-up and ramp-down profiles we be made available to the operator via drop-down lists for loading into appropriate text fields. This is useful in configuring how the infusion pump is to deliver the final solution to the patient, so as not to start the delivery of the nutrients too quickly (ramp up) nor to abruptly discontinue feeding toward the end of the final solution container (ramp down). The bar coding on the final solution container provides information and/or instructions to the infusion pump regarding the selected flow rate and/or ramp up/ramp down times. Manual entries will also be allowed. If the operator needs to add a new infusion pump to the inventory (primarily because the patient has a different infusion pump already installed at their bedside or home) this may be accomplished by selecting "Add a New Infusion Pump" selection 497, whereupon screen 498 (FIG. 18B) is presented to the operator. As shown in FIG. 18B, the operator has the capability to enter a description for the infusion pump as well as certain particulars about the new pump. If the operator decides to save the information into the inventory, he selects "Update," otherwise, the operator can delete the record to start over again, cancel to exit this screen without changing the inventory configuration.

[0211] With respect to interfacing compounding system 10 to other information systems, such as hospital or home care pharmacy systems, the inventors have determined that electronic handshaking and protocols necessary to carry out this interface are complicated, add additional cost, and may be counter to the desires of the hospital to maintain autonomy of their systems. Thus, a further embodiment of the present invention provides an interface that is less complex and does not rely on handshaking protocols to transfer compounding information to compounding system 10.

[0212] Referring now to FIG. 22, a block diagram of hospital or home care pharmacy system 2200 is illustrated. As shown in FIG. 22, system 2200 comprises input devices, such as keyboard 2202 and mouse 2204, processor 2206 (shown for example as contained within display device 2208), and printer 2214. In one non limiting example, system 2200 may be centrally located on a patient floor. In another non limiting example, system 2200 may be part of a hand held computing device, such as a PDA and may include or be detachably coupled to a small printer via either direct wiring (USB, fire wire interface, etc.) or via well-known wireless communication link.

[0213] Referring again to FIG. 22, when a physician determines the needs of a patient, the physician may enter or have entered into system 2200 a desired compound defining solution types and respective volumes. The desired compound is displayed to the physician via display 2208 where, upon verification for accuracy, a printout of the required compound is output from printer 2214 as paper or label 2216. Although a standard printed page may be useable to carry out the present invention, it may be desirable to use label material as will become evident below.

[0214] In one exemplary embodiment, indicia in the form of a barcode may be imprinted as part of label **2216**. It is contemplated that various fields of the barcode will indicate certain characteristics of the desired compound. All necessary information to prepare a desired compound is included within the barcode, including desired solutions and respective volumes, patient ID (not absolutely necessary but highly desirable in order to prevent administering the compound to the wrong patient), order number, and compound bag ID number. An example of Barcode fields is listed below:

[0215] 1. "O"=Barcode Identifier Code (upper case letter 'O').

[0216] 2. Order Control Flags (see notes below)

[0217] 3. Patient ID, maximum of 12 characters (see notes below)

[0218] 4. Order ID, maximum of 30 characters (see notes below)

[0219] 5. Bag ID, maximum of 12 characters (see notes below)

[0220] 6. Station #1 Volume: value can be 0, 5.0 to 99.9, or 100 to 5000 mL

[0221] 7. Station #1 Solution Name, blank to skip station programming

[0222] 8. Station #2 Volume: value can be 0, 5.0 to 99.9, or 100 to 5000 mL

[0223] 9. Station #2 Solution Name, blank to skip station programming

[0224] 10. Station #3 Volume: value can be 0, 5.0 to 99.9, or 100 to 5000 mL

[0225] 11. Station #3 Solution Name, blank to skip station programming

[0226] 12. Station #4 Volume: value can be 0, 5.0 to 99.9, or 100 to 5000 mL

[0227] 13. Station #4 Solution Name, blank to skip station programming

[0228] 14. Station #5 Volume: value can be 0, 5.0 to 99.9, or 100 to 5000 mL

[0229] 15. Station #5 Solution Name, blank to skip station programming

[0230] 16. Station #6 Volume: value can be 0, 5.0 to 99.9, or 100 to 5000 mL

[0231] 17. Station #6 Solution Name, blank to skip station programming

[0232] 18. Station #7 Volume: value can be 0, 5.0 to 99.9, or 100 to 5000 mL

[0233] 19. Station #7 Solution Name, blank to skip station programming

[0234] 20. Station #8 Volume: value can be 0, 5.0 to 99.9, or 100 to 5000 mL

[0235] 21. Station #8 Solution Name, blank to skip station programming

[0236] 22. Station #9 Volume: value can be 0, 5.0 to 99.9, or 100 to 5000 mL

[0237] 23. Station #9 Solution Name, blank to skip station programming

[0238] Exemplary barcode content for a non-limiting example of a TPN order is listed below and an exemplary barcodes **2300** is illustrated in FIG. **23A**.

[0239] O,L,111-11-1111,RX12345-Abc,0001,250, FreAmine 15%,180,

[0240] Dextrose 50%,55.5,Hyperlyte CR,,,,,,,,,450,Sterile Water

[0241] It is also contemplated that other types of labels may be implemented to carry out the present invention, such as

RFID tags. In such an implementation, the RFID tag includes the information outlined above and may be accessed using conventional RFID activation systems. Such systems transmit and RF signal to the RFID tag in order to activate the tag, which in turn transmits its information to a local receiver, normally incorporated within the RFID activation system.

[0242] Barcode Explanation:

[0243] Although the following is directed to bar coded embodiments, it is equally applicable to an RFID implementation.

[0244] The entire barcode should desirably be one line (do not include carriage returns within the line, but a carriage return should be present at the end of the line).

[0245] The first 2 fields identify the barcode and specify a (L)ocked order. Since the order is "locked", it is prevented from being modified by the pharmacy technician and can only be compounded as originally ordered.

[0246] The Patient ID is '111-11-1111'.

[0247] The Order ID is 'RX12345-Abc'.

[0248] The Bag ID is '0001'.

[0249] Station **1** will be programmed for 250 mL of FreAmine 15%.

[0250] Station **2** will be programmed for 180 mL of Dextrose 50%.

[0251] Station **3** will be programmed for 55.5 mL of Hyperlyte CR.

[0252] Stations **4** through **8** will not be changed.

[0253] Station **9** will be programmed for 450 mL of Sterile Water.

[0254] Exemplary barcode content for a non-limiting example of a Library Formula or Quick Setup is listed below and an exemplary two dimensional barcode **2300** is illustrated in FIG. **23B**.

[0255] Barcode Content:

[0256] O,,,,,0, FreAmine 15%,0,Dextrose 50%,0,Hyperlyte CR,0, Trophamine 10%,0, FreAmine HBC 6.9%,0, Dex 5%/0.2% NaCl,0, Liposyn 30%,0, Tham 0.3 Molar Sol,0, Sterile Water

[0257] Barcode Explanation:

[0258] The entire barcode should desirably be one line (do not include carriage returns).

[0259] The first field identifies the barcode.

[0260] The order is allowed to be manually adjusted after loading. No Patient ID is specified.

[0261] No Order ID is specified (so it will be automatically recorded as 'Manual ###').

[0262] No Bag ID is specified.

[0263] Station **1** will be programmed for FreAmine 15%.

[0264] Station **2** will be programmed for Dextrose 50%.

[0265] Station **3** will be programmed for Hyperlyte CR.

[0266] Station **4** will be programmed for Trophamine 10%.

[0267] Station **5** will be programmed for FreAmine HBC 6.9%.

[0268] Station **6** will be programmed for Dex 5%/0.2% NaCl.

[0269] Station **7** will be programmed for Liposyn 30%.

[0270] Station **8** will be programmed for Tham 0.3 Molar Sol.

[0271] Station **9** will be programmed for Sterile Water.

[0272] All station volumes will be reset to zero.

[0273] Alternately, the code may contain all pertinent information such as solution name and volume information, but may lack information with respect to specific stations into

which the source solution is to be placed. In this example, the Compounder would determine any new or already existing source solution placements with those contained in the bar coded prescription order.

[0274] After the barcode label is printed, it is physically transferred to location where the compounder, such as compounding system **10**, is located. Referring again to FIG. **1**, barcode label **2216** may desirably be attached to a final solution container **14** intended to contain the desired compound. By attaching the barcode label to the solution container before compounding begins, errors may be minimized. Next, the barcode label **2216** of final solution container **14** is scanned into system **10** using barcode scanner **82**. As discussed above with respect to the compounding system **10** embodiments, the system will direct the operator to install the correct source solutions to the appropriate stations before allowing compounding to begin. Once compounding is complete, system **10** may optionally produce another barcode label, such as that illustrated in FIG. **24**, in which a compounding summary **2400** is contained. As shown in FIG. **24**, a non-limiting example of compounding summary **2400** includes Order ID **2402**, Operator information **2404**, Start Time **2406**, Job Time **2408**, Job Status **2410**, and details of the solution **2412**. Additionally result barcode **2414** is included which contains all information necessary to verify that the solution in container **14** is as intended.

[0275] Used in conjunction with the Order barcode **2300**, the Result barcode **2414** provides another way to move information reliably. As mentioned above, result barcode **2414** is printed on the compounding summary page, in any desired location. Result barcode **2414** contains basically the same information as the compounding summary header, which includes the compounding order identification, compounding date and time, and the compounding result code.

[0276] Examples of Result barcode fields are as follows:

[0277] 1. "R"—Barcode Identifier Code.

[0278] 2. Result Code: (C)ompleted, (A)borted, (F)ailed (see notes below).

[0279] 3. Patient ID, maximum of 12 characters.

[0280] 4. Order ID, maximum of 30 characters.

[0281] 5. Bag ID, maximum of 12 characters.

[0282] 6. Compounding Date, "mm/dd/yyyy" format.

[0283] 7. Compounding Time, "hh:mm" format (24 hour).

Note—The result code for a compounding operation can be one of the following:

[0284] "C"—Completed successfully.

[0285] "A"—Aborted by operator.

[0286] "F"—Failed due to unrecoverable delivery error.

[0287] Verification of the solution in container **14** is simply conducted by scanning barcode label **2414** and comparing the information contained therein with the information in the system based on either the memory of the initially scanned barcode label **2300** or the patient record. In one exemplary embodiment, result barcode **2414** may be scanned into compounding system **10** for comparison with the information contained in barcode label **2300**. Alternatively, and/or additionally, result barcode **2414** may be scanned by personnel before administering the compound to the patient using scanner **2210** of system **2200** (see FIG. **22**). If an error is detected in the comparison, the operator is alerted so that corrective measures can be taken, such as recreating the compound or conducting self-test of the systems. If the comparison is successful the operator may be notified as well.

[0288] Although examples discussed above may relate to a bar code system, the invention is not so limited in that, as identified above, RFID tags may be used as a means to convey compounding information to the compounder and compound solution information from the compounder system back to the ordering system of other check point to verify compliance.

[0289] Features of the invention are set forth in the following claims.

[0290] Although the invention is illustrated and described herein with reference to specific embodiments, the invention is not intended to be limited to the details shown. Rather, various modifications may be made in the details within the scope and range of equivalents of the claims and without departing from the invention.

What is claimed:

1. A method for use with a data entry system for providing input data to a pharmaceutical compounding device having an associated plurality of source solutions, the method comprising the steps of:

- a) generating a first label comprising first indicia defining an allocation of said plurality of source solutions;
- b) providing said first label directly to said pharmaceutical compounding device;
- c) reading said first indicia from said first label with said pharmaceutical compounding device; and
- d) generating a pharmaceutical compound with said pharmaceutical compounding device based on said first indicia input into said pharmaceutical compounding device.

2. The method according to claim 1, wherein said first indicia further comprises information relating to a patient for which the pharmaceutical compound is intended.

3. The method according to claim 1, wherein said first indicia comprises a bar code.

4. The method according to claim 1, wherein said first indicia comprises a two dimensional bar code.

5. The method according to claim 1, wherein said first label is an electronic label.

6. The method according to claim 5, wherein said electronic label is a Radio Frequency Identification label.

7. The method according to claim 6, wherein the providing step (b) comprises the steps of:

- activating said electronic label with an RF signal; and
- transmitting said indicia responsive to said RF signal.

8. The method according to claim 1, wherein said data entry system generates said first label.

9. The method according to claim 1, wherein at least one of the first indicia or second indicia includes information for instructing an infusion pump regarding delivery of the generated pharmaceutical compound to a patient.

10. The method according to claim 1, wherein the first indicia includes information for instructing an operator of the pharmaceutical compounding device at which pumping stations to install respective ones of said plurality of source solutions.

11. The method according to claim 10, further comprising the steps of:

- scanning a bar code of said installed plurality of source solutions;
- scanning a bar code of respective ones of transfer tubing coupled to said plurality of source solutions and said pump station;
- comparing the scanned information of the installed plurality of source solutions and transfer tubing with an expected configuration; and

either permitting the operator to commence compounding if the comparison is valid or preventing the operator from compounding if the comparison is invalid.

12. The method according to claim **1**, wherein Step d) comprises the steps of:

d1) pumping a first portion of at least one of the source solutions at a first flow rate with a first pump element until a predetermined threshold of the source solution is reached, and

d2) pumping a remaining portion of the at least one source solution at a second flow rate with the first pump element until a target volume of the source solution is reached, the second flow rate being less than the first flow rate.

13. The method according to claim **1**, further comprising the step of generating a second label comprising second indicia indicative of at least said pharmaceutical compound as generated by said pharmaceutical compounding device.

14. The method according to claim **1**, wherein the pharmaceutical compound is a TPN compound.

15. A method for use with a data entry system for providing input data to a pharmaceutical compounding device having an associated plurality of source solutions, the method comprising the steps of:

a) generating a first label comprising first indicia defining an allocation of said plurality of source solutions conforming to a predetermined configuration;

b) providing said first indicia to said pharmaceutical compounding device as an input;

c) reading said first indicia from said first label with said pharmaceutical compounding device; and

d) generating a pharmaceutical compound based on said indicia input into said pharmaceutical compounding device by pumping at least two separate sources of a first type of source solution simultaneously into a designated receptacle.

* * * * *