

(19) (KR)
(12) (B1)

(51) 。 Int. Cl.⁶
H01L 21/027

(45)
(11)
(24)

2004 05 17
10-0420910
2004 02 19

(21) 10-1996-0028361
(22) 1996 07 13

(65)
(43)

10-1997-0008324
1997 02 24

(30) 60/001,166 1995 07 14 (US)

(73) 75265 13500

(72) 75240 7240

(74)
:

(54)

(etchstop) (sacrificial layer)

(213, 214)

(211, 212)

(213, 214)

(206)

도 2a 내지 도 2h

1a 1d
2a 2h
3 1
4a 4d
5
6
7a 7b 3
8a 8e 4
9a 9d 5

1

2

< 202, 402, 702 :
203 : SiO₂

>

204, 404, 706, 803 :
 206, 406, 806 :
 208, 217, 218, 710, 714, 917, 918 : TiN
 210, 211, 212, 213, 214, 410, 411, 413, 414, 720, 810, 811, 822, 911, 912 :
 408, 808, 821, 822, 823, 824 :
 450 :
 704 :
 708 :
 712 : Al

가 (FETs) ,
 (reticle)
 (current light stepper) 365nm (0.01 μ m 가
 0.30 μ m I- I-
 1a 1c (1a) (
 1b), 가 (1c). 가
 (redge) (species)
 (1d). (strip)
 aligned) (TiSi₂) (self-
 가
 , (2) / (3) , (1)
 (liftoff layer)
 : 가
 (,)
 , (1) , (2)
 , / (3)

< 1 >
2a 2h

(1) P N (100) (203), (202) 6-10nm
(204), 300-500nm 가
(206) 55nm (TiN) (208) TiN (208) I-
(206) ('BARC') , TiN 365nm TiN
BARC가 가 (203)
(2) TiN BARC(208) 1μm I- (210) (spin on) (210)
(210) (softbake)
2a 2b
(3) 0.33μm I- (210) 2c 2d
(211 212)
'W' 0.33μm 2c 2d , 2c 2d C-C
(4) (213-214) (211-212) W 1.5mTorr 80%
20% TiN(208) 160nm/min 0.25μm W 15
0.04μm 0.33μm W-2 W
(213-214) 2e 2f
(5) TiN (208) (206) (etcher) (206) 200nm/min TiN
, 15 6mTorr TiN (217-218) 가 TiN (206)
, 2g 2h , (206) W-2 W
, (206) TiN (217-218) (213-214) 6mTorr
Cl₂, HBr, He/O₂ (80%/20%) Cl₂/HBr/He-O₂ Br
300 (204) SC1 (3
)
TiN

< 2 >
4a 4d

(403) 6nm 가 (100) (402) (406)
(404), 가 400nm
(1) (406) 200nm BARC , BARC (408) 365nm
BARC (408) BARC가
(406) (410)
(2) BARC (408) 1μm (410) (419)
4a
(3) 0.30μm 가 I- (410)
(411 412)
'W' 0.30μm
(4) BARC (408) 25-75mTorr CHF
3/CF₄/O₂ CHF₃/O₂ , CHF₃ CF₄ CHF
() BARC
, CF₄ O₂ ,가
5 가 BARC ,가

(411-412) W , W-2 W (413-414)
W 0 200nm BARC , BARC가 ,
BARC 1/10 , BARC가 (406) 4c 4
0.30 μ m 가 0.25 μ m (413-414)
W-2 W 가 (406) , (413-414) SF₆ H 가
Br 가 (4) BARC 4d BARC (450) ,
6 (microtrenching) 300 , (404)
Cl₂/HBr/He-O₂ , BARC , 2)가
(BARC 가)가
BARC 가 < 3 > 가
3 TiN (diffusion barrier)
TiN (cladding) , 7a (702) (704) (704)
FET / (712) (via; 708) (7
06) TiN (710 714) (720) , W I-
TiN (714) (720) W-2 W
TiN (714) (720) 7b (720) TiN(710)
TiN(714), Al(712), (720) TiN(71
4) TiN(71) TiN(71)
< 4 > TiN(71) TiN(71)
8a 8d 4
(804) (100) (802) (803), 6nm
(804) 400nm 가 (806)
(1) (806) I- BARC 가 200nm TiN (808) TiN
TiN (sputtering) N₂ Ti (sputtering)
, BARC(808)
(2) BARC (808) 1 μ m (810) (810)
(3) 0.30 μ m 8a I- (810)
8a 0.30 μ m (811 812)
(4) BARC (808) 'W' 8c TiN BARC
6mTorr 가 200nm/min TiN ,
60 TiN BARC (821-822) (806) (6)
(5) BARC (823-824) 0.025 μ m BARC (821-822) 0.25 μ m
ARC 5nm/min TiN W-2 W H₂O₂ 8d TiN B
(811-812) BARC 5
가 , BARC(823-824) (806)
W-2 W
(6) (811-812) , BARC(8
23-824) (806) . BARC(823-824)
RC , 8e , BA
BARC

가 BARC , BARC

< 5 >
9a 9d 5

(1) 300nm (906) 50nm TiN (917-918) (BARC) (911-912) TiN BARC 9a

(2) (911-912) TiN (917-918) Cl Br (911-912) (906) 9b

(3) SC1(1 29% NH₄ OH, 1 30% H₂O₂, 6 H₂O) TiN(917-918) 9c (913-914) (911-912) (ash) Ti

N(917-918) Tin(917-918) TiN

가 (913-914) BARC (917-918) BARC (913-914) BARC 가

9a BARC

3

, BARC 가 , 1, 2, 3 가 가

가 BARC

I-

RIE, ECR

RIE,

- (57)
1.
 - (a) ;
 - (b) ;
 - (c) ;
 - (d) ;
 - (e) 1 ;
 - (f) 1 2 ;
 - (g) 2
 2.
 - 1
 - (a) TiN ,
 - (b)
 3.
 - 2
 - (a) 1
 4.
 - 3

- (a) ,
 (b) .
5. ;
 (a) (BARC)
 (b) 1 ;
 (c) 1 BARC ;
 (d) 1 W ;
 (e) BARC , W 1
 (f) 1 BARC 1 BAR
 C W , W-2 W 2
 BARC ;
 (g) 2 BARC

- 6.**
 5
 (a) BARC TiN
7. ;
 (a) (BARC)
 (b) 1 ;
 (c) 1 BARC ;
 (d) 1 W ;
 (e) BARC ,
 W BARC ;
 (f) BARC ;
 (g) ;
 (h) BARC BAR
 C

- 8.**
 5
 (a) BARC TiN

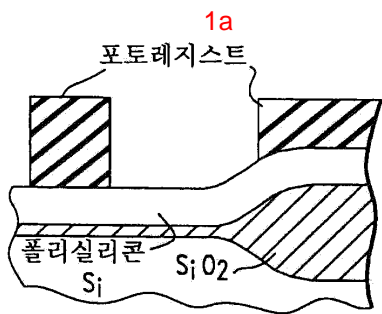

1b

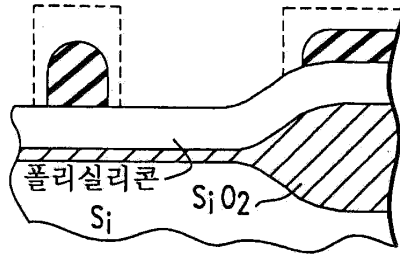

1c

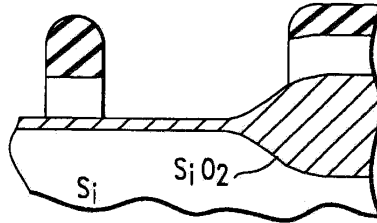

1d

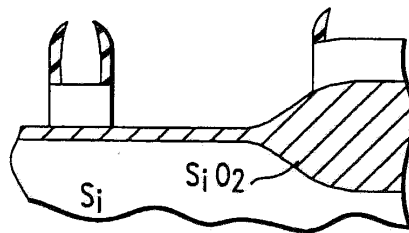

2a

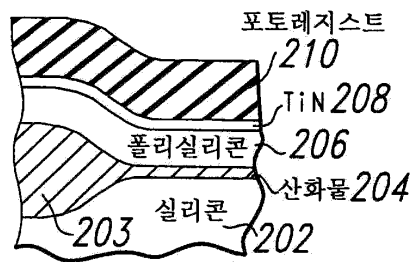

2b

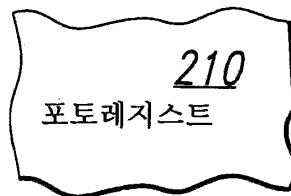

2c

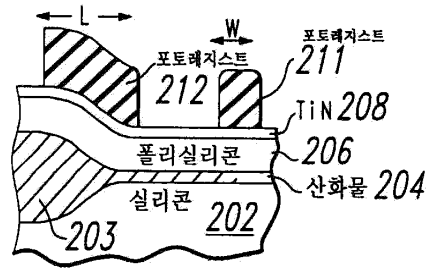

2d

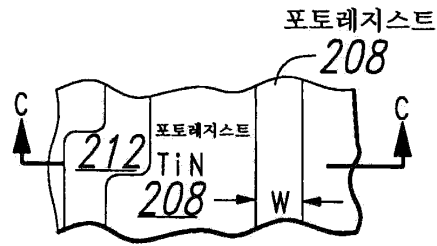

2e

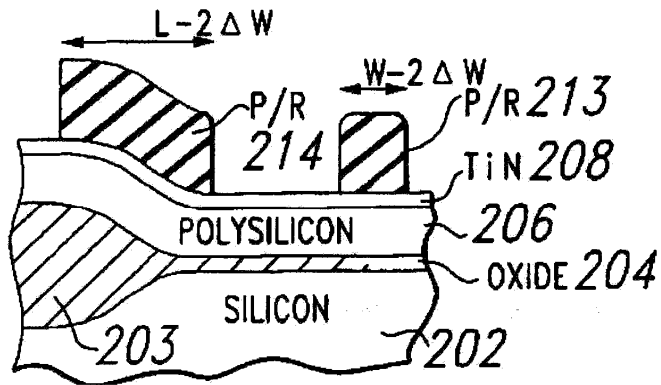

2f

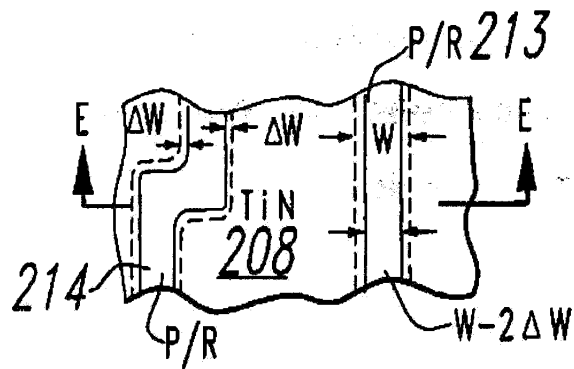

2g

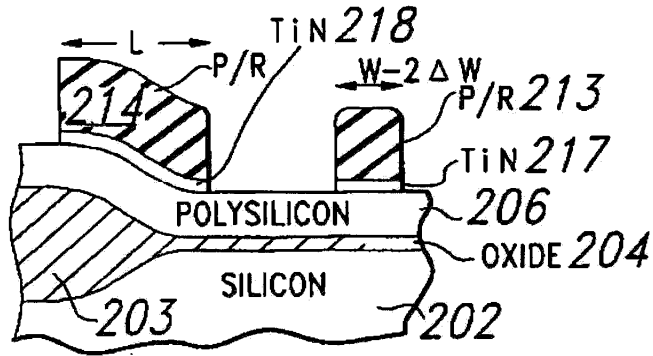

2h

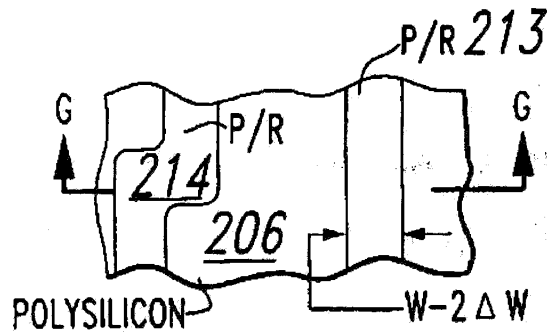

3

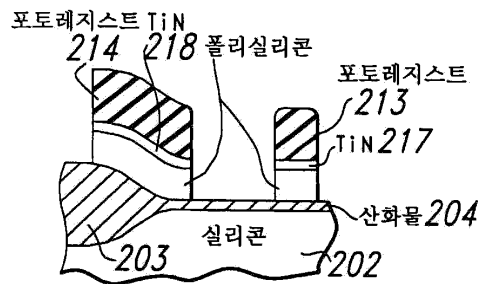

4a

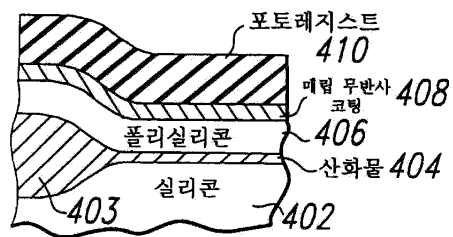

4b

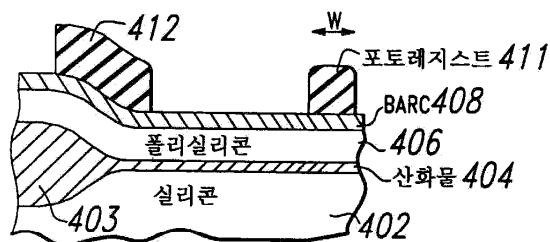

4c

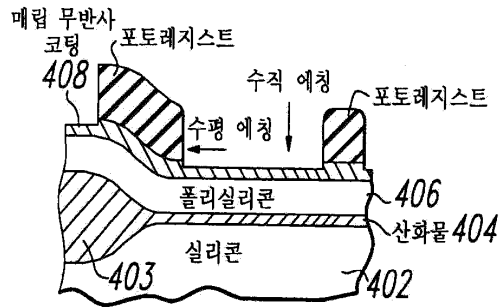

4d

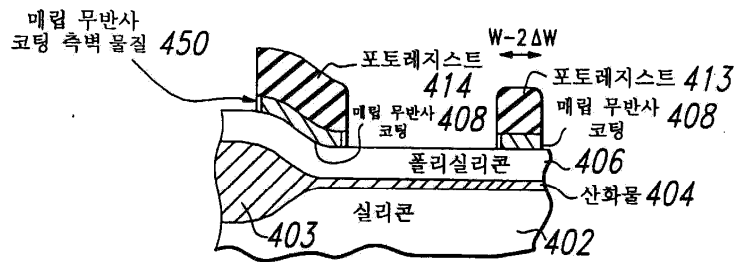

5

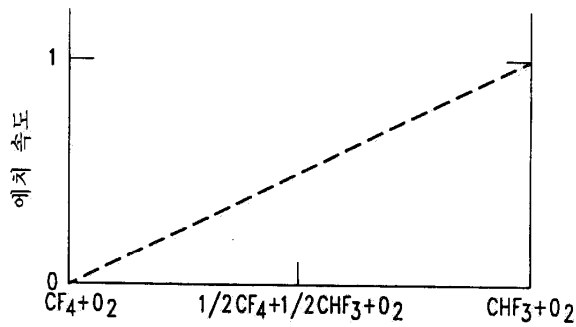

6

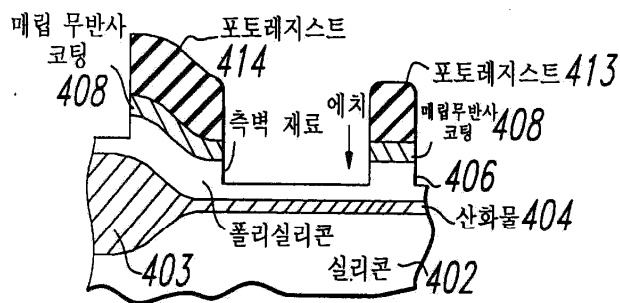

7a

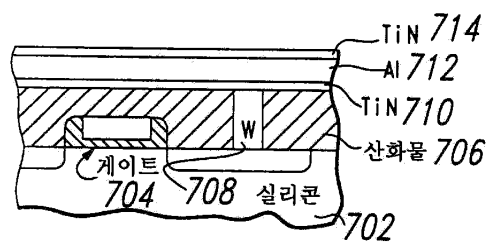

7b

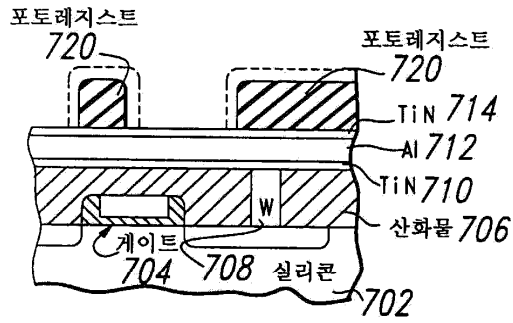

8a

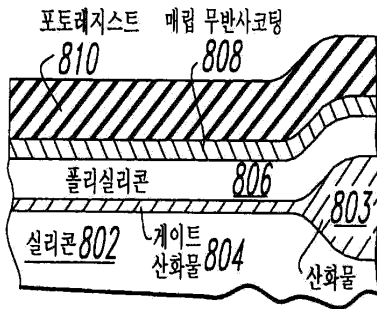

8b

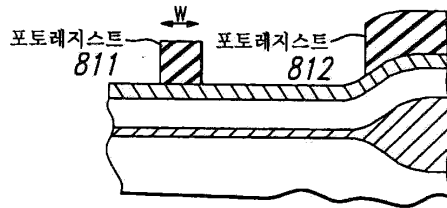

8c

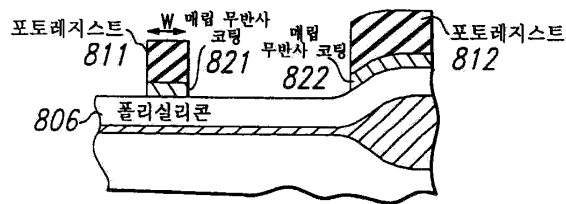

8d

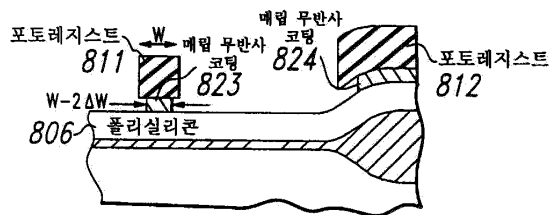

8e

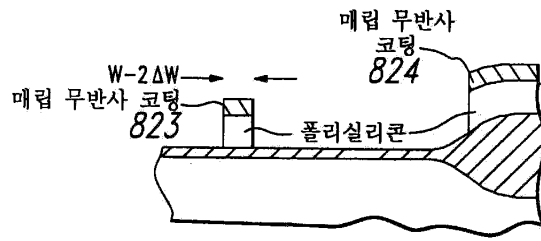

9a

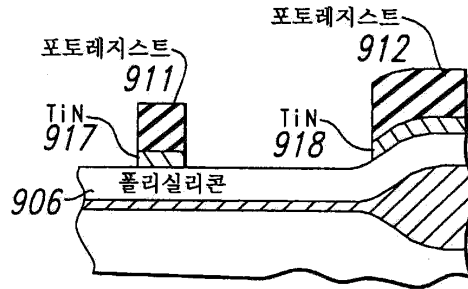

9b

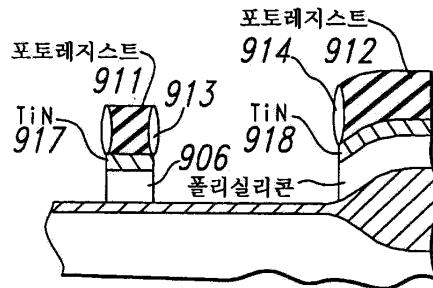

9c

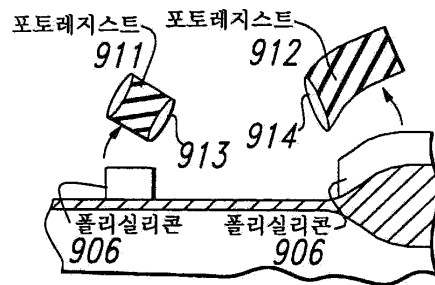

9d

