



US011163720B2

(12) **United States Patent**  
**Abdallah**

(10) **Patent No.:** **US 11,163,720 B2**

(45) **Date of Patent:** **Nov. 2, 2021**

(54) **APPARATUS AND METHOD FOR PROCESSING AN INSTRUCTION MATRIX SPECIFYING PARALLEL AND DEPENDENT OPERATIONS**

(71) Applicant: **Intel Corporation**, Santa Clara, CA (US)

(72) Inventor: **Mohammad A. Abdallah**, Folsom, CA (US)

(73) Assignee: **Intel Corporation**, Santa Clara, CA (US)

(\* ) Notice: Subject to any disclaimer, the term of this patent is extended or adjusted under 35 U.S.C. 154(b) by 12 days.

(21) Appl. No.: **16/371,831**

(22) Filed: **Apr. 1, 2019**

(65) **Prior Publication Data**

US 2019/0227982 A1 Jul. 25, 2019

**Related U.S. Application Data**

(63) Continuation of application No. 15/853,323, filed on Dec. 22, 2017, now Pat. No. 10,289,605, which is a (Continued)

(51) **Int. Cl.**  
**G06F 9/30** (2018.01)  
**G06F 15/80** (2006.01)  
(Continued)

(52) **U.S. Cl.**  
CPC ..... **G06F 15/8007** (2013.01); **G06F 7/5338** (2013.01); **G06F 9/3001** (2013.01);  
(Continued)

(58) **Field of Classification Search**  
None  
See application file for complete search history.

(56) **References Cited**

U.S. PATENT DOCUMENTS

727,487 A 5/1903 Swan  
4,075,704 A 2/1978 O'Leary  
(Continued)

FOREIGN PATENT DOCUMENTS

CN 1120224 A 4/1996  
CN 1214666 A 4/1999  
(Continued)

OTHER PUBLICATIONS

Decision to Grant a Patent from foreign counterpart Korean Patent Application No. 20137033565, dated Apr. 29, 2016, 2 pages.

(Continued)

*Primary Examiner* — Corey S Faherty

(74) *Attorney, Agent, or Firm* — Nicholson De Vos Webster & Elliott, LLP

(57) **ABSTRACT**

An execution unit to execute instructions using a time-lag sliced architecture (TLSA). The execution unit includes a first computation unit and a second computation unit, where each of the first computation unit and the second computation unit includes a plurality of logic slices arranged in order, where each of the plurality of logic slices except a lattermost logic slice is coupled to an immediately following logic slice to provide an output of that logic slice to the immediately following logic slice, where the immediately following logic slice is to execute with a time lag with respect to its immediately previous logic slice. Further, each of the plurality of logic slices of the second computation unit is coupled to a corresponding logic slice of the first computation unit to receive an output of the corresponding logic slice of the first computation unit.

**18 Claims, 25 Drawing Sheets**

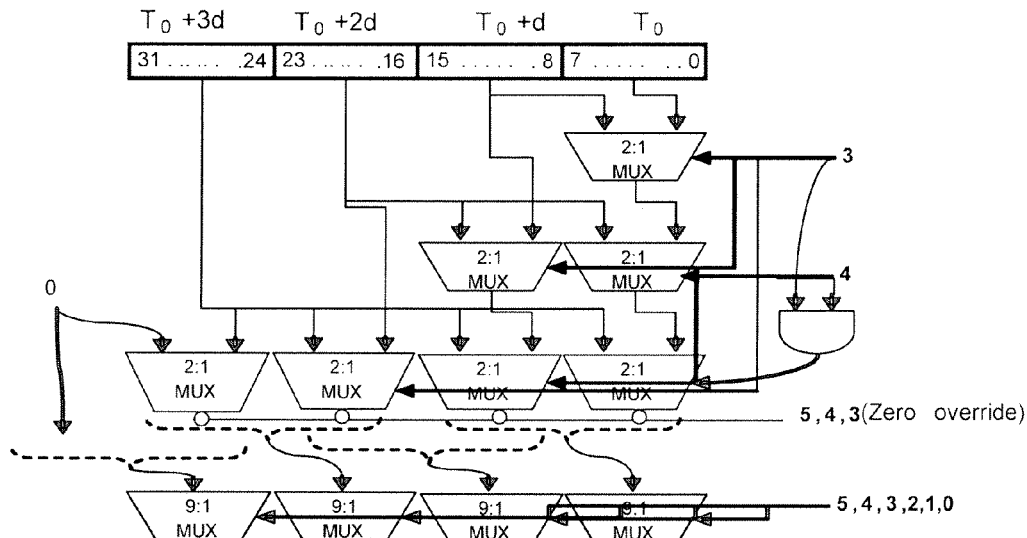

**Related U.S. Application Data**

continuation of application No. 14/733,827, filed on Jun. 8, 2015, now Pat. No. 9,886,416, which is a continuation of application No. 13/691,609, filed on Nov. 30, 2012, now Pat. No. 9,053,292, which is a continuation of application No. 12/296,919, filed as application No. PCT/US2007/066536 on Apr. 12, 2007, now Pat. No. 8,327,115.

(60) Provisional application No. 60/792,219, filed on Apr. 14, 2006, provisional application No. 60/791,782, filed on Apr. 12, 2006, provisional application No. 60/791,649, filed on Apr. 12, 2006.

(51) **Int. Cl.**

**G06F 7/533** (2006.01)  
**G06F 9/38** (2018.01)  
**G06F 7/483** (2006.01)  
**G06F 7/53** (2006.01)  
**G06F 7/544** (2006.01)

(52) **U.S. Cl.**

CPC ..... **G06F 9/3012** (2013.01); **G06F 9/3016** (2013.01); **G06F 9/30109** (2013.01); **G06F 9/30123** (2013.01); **G06F 9/30141** (2013.01); **G06F 9/30181** (2013.01); **G06F 9/30189** (2013.01); **G06F 9/3824** (2013.01); **G06F 9/3828** (2013.01); **G06F 9/3838** (2013.01); **G06F 9/3851** (2013.01); **G06F 9/3853** (2013.01); **G06F 9/3867** (2013.01); **G06F 9/3885** (2013.01); **G06F 9/3887** (2013.01); **G06F 9/3889** (2013.01); **G06F 9/3891** (2013.01); **G06F 15/80** (2013.01); **G06F 7/483** (2013.01); **G06F 7/5318** (2013.01); **G06F 7/5443** (2013.01)

(56) **References Cited**

U.S. PATENT DOCUMENTS

4,245,344 A 1/1981 Richter  
4,356,550 A 10/1982 Katzman et al.  
4,414,624 A 11/1983 Summer, Jr. et al.  
4,524,415 A 6/1985 Mills, Jr. et al.  
4,527,237 A 7/1985 Frieder et al.  
4,577,273 A 3/1986 Hopper et al.  
4,597,061 A 6/1986 Cline et al.  
4,600,986 A 7/1986 Scheuneman et al.  
4,633,434 A 12/1986 Scheuneman  
4,682,281 A 7/1987 Woffinden et al.  
4,727,487 A 2/1988 Masui et al.  
4,816,991 A 3/1989 Watanabe et al.  
4,835,680 A 5/1989 Hogg et al.  
4,920,477 A 4/1990 Colwell et al.  
4,930,066 A 5/1990 Yokota  
4,943,909 A 7/1990 Huang  
5,197,130 A 3/1993 Chen et al.  
5,294,897 A 3/1994 Notani et al.  
5,317,705 A 5/1994 Gannon et al.  
5,317,754 A 5/1994 Blandy et al.  
5,339,398 A 8/1994 Shah et al.  
5,404,470 A 4/1995 Miyake  
5,421,019 A \* 5/1995 Holsztyński ..... G06F 15/8023  
712/14  
5,469,376 A 11/1995 Abdallah  
5,471,593 A 11/1995 Branigin  
5,488,730 A 1/1996 Brown et al.  
5,509,130 A 4/1996 Trauben et al.  
5,517,651 A 5/1996 Huck et al.  
5,524,090 A 6/1996 Iwamura  
5,548,742 A 8/1996 Wang et al.  
5,548,773 A \* 8/1996 Kemeny ..... G06F 30/18  
712/11

5,559,986 A 9/1996 Alpert et al.  
5,574,878 A 11/1996 Onodera et al.  
5,581,725 A 12/1996 Nakayama  
5,590,084 A 12/1996 Miyano et al.  
5,634,068 A 5/1997 Nishtala et al.  
5,649,136 A 7/1997 Shen et al.  
5,675,759 A 10/1997 Shebanow et al.  
5,699,537 A 12/1997 Sharangpani et al.  
5,710,902 A 1/1998 Sheaffer et al.  
5,724,565 A 3/1998 Dubey et al.  
5,751,982 A 5/1998 Morley  
5,752,260 A 5/1998 Liu  
5,754,818 A 5/1998 Mohamed  
5,761,476 A 6/1998 Martell  
5,787,494 A 7/1998 Delano et al.  
5,793,941 A 8/1998 Pencis et al.  
5,802,602 A 9/1998 Rahman et al.  
5,806,085 A 9/1998 Berliner  
5,813,031 A 9/1998 Chou et al.  
5,819,088 A 10/1998 Reinders  
5,829,028 A 10/1998 Lynch et al.  
5,835,951 A 11/1998 McMahan  
5,852,738 A 12/1998 Bealkowski et al.  
5,860,146 A 1/1999 Vishin et al.  
5,864,657 A 1/1999 Stiffler  
5,872,985 A 2/1999 Kimura  
5,881,277 A 3/1999 Bondi et al.  
5,901,294 A 5/1999 Tran et al.  
5,903,750 A 5/1999 Yeh et al.  
5,905,509 A 5/1999 Jones et al.  
5,911,057 A 6/1999 Shiell  
5,918,251 A 6/1999 Yamada et al.  
5,956,753 A 9/1999 Glew et al.  
5,974,506 A 10/1999 Nicola et al.  
5,978,906 A 11/1999 Tran  
5,983,327 A 11/1999 Achilles et al.  
6,016,533 A 1/2000 Tran  
6,016,540 A 1/2000 Zaidi et al.  
6,021,484 A 2/2000 Park  
6,035,120 A 3/2000 Ravichandran  
6,065,105 A 5/2000 Zaidi et al.  
6,073,230 A 6/2000 Pickett et al.  
6,075,938 A 6/2000 Bugnion et al.  
6,085,315 A 7/2000 Fleck et al.  
6,088,780 A 7/2000 Yamada et al.  
6,092,172 A 7/2000 Nishimoto et al.  
6,101,577 A 8/2000 Tran  
6,108,769 A 8/2000 Chinnakonda et al.  
6,115,809 A 9/2000 Mattson, Jr. et al.  
6,134,634 A 10/2000 Marshall, Jr. et al.  
6,138,226 A 10/2000 Yoshioka et al.  
6,157,998 A 12/2000 Rupley, II et al.  
6,167,490 A 12/2000 Levy et al.  
6,170,051 B1 1/2001 Dowling  
6,178,482 B1 1/2001 Sollars  
6,185,660 B1 2/2001 Mulla et al.  
6,205,545 B1 3/2001 Shah et al.  
6,209,085 B1 3/2001 Hammond et al.  
6,212,542 B1 4/2001 Kahle et al.  
6,212,613 B1 4/2001 Belair  
6,216,215 B1 4/2001 Palanca et al.  
6,226,732 B1 5/2001 Pei et al.  
6,247,097 B1 6/2001 Sinharoy  
6,253,316 B1 6/2001 Tran et al.  
6,256,727 B1 7/2001 McDonald  
6,256,728 B1 7/2001 Witt et al.  
6,260,131 B1 7/2001 Kikuta et al.  
6,260,138 B1 7/2001 Harris  
6,269,439 B1 7/2001 Hanaki  
6,272,616 B1 8/2001 Fernando et al.  
6,272,662 B1 8/2001 Jadav et al.  
6,275,917 B1 8/2001 Okada  
6,282,583 B1 8/2001 Pincus et al.  
6,282,638 B1 8/2001 Dowling  
6,308,323 B1 10/2001 Douniwa  
6,321,298 B1 11/2001 Hubis  
6,327,650 B1 12/2001 Bapst et al.  
6,332,189 B1 12/2001 Baweja et al.  
6,339,822 B1 1/2002 Miller

(56)

## References Cited

## U.S. PATENT DOCUMENTS

6,341,324 B1	1/2002	Caulk, Jr. et al.	7,577,820 B1	8/2009	Wentzlaff et al.
6,345,357 B1	2/2002	Sato	7,613,131 B2	11/2009	Decasper et al.
6,360,311 B1	3/2002	Zandveld et al.	7,617,384 B1	11/2009	Coon et al.
6,405,185 B1*	6/2002	Pechanek .....	7,627,735 B2	12/2009	Espasa et al.
		G06F 15/8023	7,634,637 B1	12/2009	Lindhholm et al.
		706/14	7,647,483 B2	1/2010	Bates et al.
6,408,367 B2	6/2002	Achilles et al.	7,680,988 B1	3/2010	Nickolls et al.
6,437,789 B1	8/2002	Tidwell et al.	7,681,019 B1	3/2010	Favor
6,449,671 B1	9/2002	Patkar et al.	7,707,397 B2	4/2010	Henry et al.
6,457,120 B1	9/2002	Sinharoy	7,707,578 B1	4/2010	Zedlewski et al.
6,473,833 B1	10/2002	Arimilli et al.	7,711,929 B2	5/2010	Burky et al.
6,490,673 B1	12/2002	Heishi et al.	7,716,460 B2	5/2010	Stempel et al.
6,502,187 B1	12/2002	Miyagawa	7,743,238 B2	6/2010	Biles
6,529,928 B1	3/2003	Resnick et al.	7,757,065 B1	7/2010	Jourdan et al.
6,542,984 B1	4/2003	Keller et al.	7,770,161 B2	8/2010	Mitran et al.
6,557,083 B1	4/2003	Sperber et al.	7,783,868 B2	8/2010	Ukai
6,557,095 B1	4/2003	Henstrom	7,783,869 B2	8/2010	Grandou et al.
6,594,755 B1	7/2003	Nuechterlein et al.	7,809,925 B2	10/2010	Mejdrich et al.
6,604,187 B1	8/2003	McGrath et al.	7,848,129 B1	12/2010	Deshpande et al.
6,609,189 B1	8/2003	Kuszmaul et al.	7,856,530 B1	12/2010	Mu
6,615,340 B1	9/2003	Wilmot, II	7,861,055 B2	12/2010	Pong
6,658,447 B2	12/2003	Cota-Robles	7,861,060 B1	12/2010	Nickolls et al.
6,658,549 B2	12/2003	Wilson et al.	7,877,582 B2	1/2011	Gschwind et al.
6,668,316 B1	12/2003	Gorshtein et al.	7,913,058 B2	3/2011	Rozas et al.
6,681,395 B1	1/2004	Nishi	7,925,869 B2	4/2011	Kelsey et al.
6,704,860 B1	3/2004	Moore	8,044,951 B1	10/2011	Brown et al.
6,721,874 B1	4/2004	Le et al.	8,046,775 B2	10/2011	Kang et al.
6,728,866 B1	4/2004	Kahle et al.	8,082,420 B2	12/2011	Comparan et al.
6,775,761 B2	8/2004	Wang et al.	8,108,545 B2	1/2012	Arimilli et al.
6,829,698 B2	12/2004	Arimilli et al.	8,108,625 B1	1/2012	Coon et al.
6,850,531 B1	2/2005	Rao et al.	8,145,844 B2	3/2012	Bruce
6,882,177 B1	4/2005	Reddy et al.	8,145,880 B1	3/2012	Cismas et al.
6,907,600 B2	6/2005	Neiger et al.	8,145,882 B1	3/2012	Kishore et al.
6,912,644 B1	6/2005	O'Connor et al.	8,200,949 B1	6/2012	Tarjan et al.
6,920,530 B2	7/2005	Musumeci	8,219,996 B1	7/2012	Morris
6,944,744 B2	9/2005	Ahmed et al.	8,230,423 B2	7/2012	Frigo et al.
6,948,172 B1	9/2005	D et al.	8,239,656 B2	8/2012	Rozas et al.
6,950,927 B1	9/2005	Apisdorf et al.	8,301,847 B2	10/2012	Dantzig et al.
6,954,846 B2	10/2005	Leibholz et al.	8,316,435 B1	11/2012	Varadhan et al.
6,985,591 B2	1/2006	Graunke	8,327,115 B2	12/2012	Abdallah
6,988,183 B1	1/2006	Wong	8,438,366 B2	5/2013	Akizuki et al.
7,007,108 B2	2/2006	Emerson et al.	8,522,253 B1	8/2013	Rozas et al.
7,020,879 B1	3/2006	Nemirovsky et al.	8,539,486 B2	9/2013	Cain, III et al.
7,047,322 B1	5/2006	Bauman et al.	8,645,965 B2	2/2014	Zimmer et al.
7,111,145 B1	9/2006	Chen et al.	8,756,329 B2	6/2014	Reynolds et al.
7,117,347 B2	10/2006	Col et al.	8,868,838 B1	10/2014	Glasco et al.
7,139,855 B2	11/2006	Armstrong et al.	8,930,674 B2	1/2015	Avudaiyappan et al.
7,143,273 B2	11/2006	Miller et al.	9,021,240 B2	4/2015	Alexander et al.
7,149,872 B2	12/2006	Rozas et al.	9,047,178 B2	6/2015	Talagala et al.
7,150,021 B1	12/2006	Vajjhala et al.	9,086,721 B2	7/2015	Jackson et al.
7,171,535 B2	1/2007	Naoi	9,112,767 B2	8/2015	Ansari et al.
7,203,824 B2	4/2007	Bean et al.	9,135,003 B2	9/2015	Suh et al.
7,206,925 B1	4/2007	Jacobson et al.	9,208,066 B1	12/2015	Mizrahi et al.
7,213,106 B1	5/2007	Koster et al.	9,575,762 B2	2/2017	Abdallah
7,213,248 B2	5/2007	Arimilli et al.	9,811,342 B2	11/2017	Abdallah et al.
7,231,106 B2	6/2007	Basavanhally et al.	9,811,377 B2	11/2017	Abdallah et al.
7,257,695 B2	8/2007	Jiang et al.	9,823,930 B2	11/2017	Abdallah et al.
7,278,030 B1	10/2007	Chen et al.	9,858,080 B2	1/2018	Abdallah
7,284,092 B2	10/2007	Nunamaker et al.	10,140,138 B2	11/2018	Abdallah et al.
7,290,261 B2	10/2007	Burky et al.	10,198,266 B2	2/2019	Abdallah
7,313,775 B2	12/2007	Casey et al.	2001/0004755 A1	6/2001	Levy et al.
7,331,040 B2	2/2008	Sandham et al.	2001/0016901 A1	8/2001	Topham
7,343,476 B2	3/2008	Floyd et al.	2001/0032303 A1	10/2001	Pechanek et al.
7,373,637 B2	5/2008	Dewitt et al.	2001/0049782 A1	12/2001	Hsu et al.
7,380,096 B1	5/2008	Rozas et al.	2002/0029308 A1	3/2002	Babaian et al.
7,383,427 B2	6/2008	Yamazaki	2002/0062435 A1	5/2002	Nemirovsky et al.
7,398,347 B1	7/2008	Pechanek et al.	2002/0069326 A1	6/2002	Richardson et al.
7,406,581 B2	7/2008	Southwell et al.	2002/0082824 A1	6/2002	Neiger et al.
7,418,579 B2	8/2008	Guibert et al.	2002/0083312 A1	6/2002	Sinharoy
7,418,582 B1	8/2008	Iacobovici et al.	2002/0099913 A1	7/2002	Steely
7,441,110 B1	10/2008	Puzak et al.	2002/0120663 A1	8/2002	Binns
7,493,475 B2	2/2009	Colavin	2002/0125585 A1	9/2002	Slamowitz et al.
7,500,043 B2*	3/2009	Wood .....	2002/0126657 A1	9/2002	Frouin et al.
		G06F 15/8007	2002/0129085 A1	9/2002	Kubala et al.
		370/464	2002/0174321 A1	11/2002	John et al.
7,539,879 B2	5/2009	Terechko et al.	2002/0188833 A1	12/2002	Henry et al.
7,546,420 B1	6/2009	Shar et al.	2003/0035422 A1	2/2003	Hill
			2003/0065887 A1	4/2003	Maiyuran et al.
			2003/0088752 A1	5/2003	Harman

(56)

## References Cited

## U.S. PATENT DOCUMENTS

2003/0093776	A1	5/2003	Hilton	2006/0179289	A1	8/2006	Floyd et al.
2003/0101322	A1	5/2003	Gardner	2006/0190707	A1	8/2006	McIlvaine et al.
2003/0101444	A1	5/2003	Wu et al.	2006/0212687	A1	9/2006	Chen et al.
2003/0126408	A1	7/2003	Vajapeyam et al.	2006/0230243	A1	10/2006	Cochran et al.
2003/0131335	A1	7/2003	Hamlin	2006/0230253	A1	10/2006	Codrescu et al.
2003/0149862	A1	8/2003	Kadambi	2006/0230409	A1	10/2006	Frigo et al.
2003/0154363	A1	8/2003	Soltis et al.	2006/0236074	A1	10/2006	Williamson et al.
2003/0163642	A1	8/2003	Borkenhagen et al.	2006/0236080	A1	10/2006	Doing et al.
2003/0169626	A1	9/2003	Burk et al.	2006/0242365	A1	10/2006	Ali et al.
2003/0200396	A1	10/2003	Musumeci	2006/0242384	A1	10/2006	Ahmed et al.
2003/0200412	A1	10/2003	Peinado et al.	2006/0256641	A1	11/2006	Johnstone
2003/0202530	A1	10/2003	Jenkins et al.	2006/0277365	A1	12/2006	Pong
2003/0208660	A1	11/2003	Van De Waerdt	2006/0282839	A1	12/2006	Hankins et al.
2003/0225938	A1	12/2003	Glasco et al.	2007/0006231	A1	1/2007	Wang et al.
2003/0226001	A1	12/2003	Moyer et al.	2007/0074005	A1	3/2007	Abernathy
2003/0229864	A1	12/2003	Watkins	2007/0186050	A1	8/2007	Luick
2003/0233394	A1	12/2003	Rudd et al.	2007/0198665	A1	8/2007	De et al.
2004/0034762	A1	2/2004	Kacevas	2007/0214343	A1	9/2007	Lindholm et al.
2004/0044850	A1	3/2004	George et al.	2007/0226722	A1	9/2007	Chou
2004/0064668	A1	4/2004	Kjos et al.	2007/0262270	A1	11/2007	Huang et al.
2004/0073909	A1	4/2004	Arimilli et al.	2008/0016507	A1	1/2008	Thomas et al.
2004/0078538	A1	4/2004	Dutt et al.	2008/0040724	A1	2/2008	Kang et al.
2004/0093483	A1	5/2004	Nguyen et al.	2008/0046666	A1	2/2008	Termaine et al.
2004/0098567	A1	5/2004	Hansen et al.	2008/0052432	A1	2/2008	Wilson et al.
2004/0103251	A1	5/2004	Alsup	2008/0077813	A1	3/2008	Keller et al.
2004/0117593	A1	6/2004	Uhlig et al.	2008/0091880	A1	4/2008	Vishin
2004/0117594	A1	6/2004	Vanderspek	2008/0104598	A1	5/2008	Chang
2004/0122887	A1	6/2004	Macy	2008/0109611	A1	5/2008	Liu et al.
2004/0138857	A1	7/2004	Souza et al.	2008/0126643	A1	5/2008	Higuchi
2004/0139441	A1	7/2004	Kaburaki et al.	2008/0126771	A1	5/2008	Chen et al.
2004/0143727	A1	7/2004	McDonald et al.	2008/0148237	A1	6/2008	Jiang et al.
2004/0158822	A1	8/2004	Sandham et al.	2008/0184211	A1	7/2008	Nickolls et al.
2004/0172523	A1	9/2004	Merchant et al.	2008/0195844	A1	8/2008	Shen et al.
2004/0187123	A1	9/2004	Tremblay et al.	2008/0209190	A1	8/2008	Bhargava et al.
2004/0193857	A1	9/2004	Miller et al.	2008/0215865	A1	9/2008	Hino et al.
2004/0202158	A1	10/2004	Takeo et al.	2008/0225987	A1	9/2008	Fazzi et al.
2004/0205296	A1	10/2004	Bearden	2008/0235500	A1	9/2008	Davis et al.
2004/0215886	A1	10/2004	Cargnoni et al.	2008/0250227	A1	10/2008	Linderman et al.
2004/0216105	A1	10/2004	Burky et al.	2008/0250232	A1	10/2008	Nakashima
2004/0216120	A1	10/2004	Burky et al.	2008/0256278	A1	10/2008	Thomas et al.
2004/0225872	A1	11/2004	Bonanno et al.	2008/0256330	A1	10/2008	Wang et al.
2005/0005085	A1	1/2005	Miyanaga	2008/0270758	A1	10/2008	Ozer et al.
2005/0027961	A1	2/2005	Zhang	2008/0270774	A1	10/2008	Singh et al.
2005/0044547	A1	2/2005	Gipp	2008/0282037	A1	11/2008	Kusachi et al.
2005/0055504	A1	3/2005	Hass et al.	2008/0320476	A1	12/2008	Wingard et al.
2005/0060457	A1	3/2005	Olukotun	2009/0019264	A1	1/2009	Correale, Jr. et al.
2005/0066131	A1	3/2005	Biles et al.	2009/0031104	A1	1/2009	Vorbach et al.
2005/0108480	A1	5/2005	Correale, Jr. et al.	2009/0063823	A1	3/2009	Burky et al.
2005/0108715	A1	5/2005	Kanai et al.	2009/0070554	A1	3/2009	Wang et al.
2005/0114603	A1	5/2005	Buti et al.	2009/0113170	A1	4/2009	Abdallah
2005/0120191	A1	6/2005	Akkary et al.	2009/0119457	A1	5/2009	Latorre et al.
2005/0120194	A1	6/2005	Kissell	2009/0138659	A1	5/2009	Lauterbach
2005/0132145	A1	6/2005	Dybsetter et al.	2009/0138670	A1	5/2009	Mutlu et al.
2005/0154867	A1	7/2005	Dewitt, Jr. et al.	2009/0150647	A1	6/2009	Mejdrich et al.
2005/0204118	A1	9/2005	Jen et al.	2009/0150890	A1	6/2009	Yourst
2005/0210457	A1	9/2005	Guilford	2009/0157980	A1	6/2009	Bruce
2005/0216920	A1	9/2005	Tewari et al.	2009/0158017	A1	6/2009	Mutlu et al.
2005/0251639	A1	11/2005	Vishin et al.	2009/0164733	A1	6/2009	Kim et al.
2005/0251649	A1	11/2005	Yamazaki	2009/0164766	A1	6/2009	Suggs et al.
2005/0262270	A1	11/2005	Latorre et al.	2009/0165007	A1	6/2009	Aghajanyan
2005/0289299	A1	12/2005	Nunamaker et al.	2009/0172344	A1	7/2009	Grochowski et al.
2005/0289530	A1	12/2005	Robison	2009/0187536	A1	7/2009	Jackson
2006/0004964	A1	1/2006	Conti et al.	2009/0240919	A1	9/2009	Alexander et al.
2006/0026381	A1	2/2006	Doi et al.	2009/0241084	A1	9/2009	Malley et al.
2006/0026408	A1	2/2006	Morris et al.	2009/0249026	A1	10/2009	Smelyanskiy et al.
2006/0036516	A1	2/2006	Glebe	2009/0251476	A1	10/2009	Jiao et al.
2006/0080380	A1	4/2006	Aizu et al.	2009/0282101	A1	11/2009	Lim et al.
2006/0094446	A1	5/2006	Duan	2009/0287912	A1	11/2009	Sendag
2006/0095720	A1	5/2006	Biles et al.	2009/0307450	A1	12/2009	Lee
2006/0143390	A1	6/2006	Kottapalli et al.	2009/0313462	A1	12/2009	Emma et al.
2006/0161421	A1	7/2006	Kissell	2009/0328053	A1	12/2009	Dice
2006/0161921	A1	7/2006	Kissell	2010/0058033	A1	3/2010	Abernathy et al.
2006/0179257	A1	8/2006	Chu et al.	2010/0064121	A1	3/2010	Alexander et al.
2006/0179277	A1	8/2006	Flachs et al.	2010/0082912	A1	4/2010	Lesartre et al.
2006/0179281	A1	8/2006	Jensen et al.	2010/0088443	A1	4/2010	Riocreux et al.
				2010/0100690	A1	4/2010	Rajamani et al.
				2010/0100704	A1	4/2010	Hill et al.
				2010/0100707	A1	4/2010	Mejdrich et al.
				2010/0115167	A1	5/2010	Tardieux et al.

(56)

## References Cited

## U.S. PATENT DOCUMENTS

2010/0115244 A1 5/2010 Jensen et al.  
 2010/0138607 A1 6/2010 Hughes et al.  
 2010/0154042 A1 6/2010 Miyamoto et al.  
 2010/0161948 A1 6/2010 Abdallah et al.  
 2010/0169578 A1 7/2010 Nychka et al.  
 2010/0169611 A1 7/2010 Chou et al.  
 2010/0205603 A1 8/2010 Merten et al.  
 2010/0211746 A1 8/2010 Tsukishiro  
 2010/0280996 A1 11/2010 Gross, IV et al.  
 2010/0286976 A1 11/2010 Gao et al.  
 2010/0299671 A1 11/2010 Kinsey  
 2010/0306503 A1 12/2010 Henry et al.  
 2010/0325394 A1 12/2010 Golla et al.  
 2010/0332805 A1 12/2010 Blasco et al.  
 2011/0010521 A1 1/2011 Wang et al.  
 2011/0055479 A1 3/2011 West et al.  
 2011/0067016 A1 3/2011 Mizrachi et al.  
 2011/0082980 A1 4/2011 Gschwind et al.  
 2011/0082983 A1 4/2011 Koktan  
 2011/0093857 A1 4/2011 Sydow et al.  
 2011/0119660 A1 5/2011 Tanaka  
 2011/0153955 A1 6/2011 Herrenschmidt et al.  
 2011/0225588 A1 9/2011 Pollock et al.  
 2012/0005462 A1 1/2012 Hall et al.  
 2012/0023318 A1 1/2012 Xing et al.  
 2012/0042105 A1 2/2012 Maeda et al.  
 2012/0042126 A1 2/2012 Krick et al.  
 2012/0066483 A1 3/2012 Boury et al.  
 2012/0089812 A1 4/2012 Smith  
 2012/0096204 A1 4/2012 Auerbach et al.  
 2012/0198209 A1 8/2012 Abdallah et al.  
 2012/0246448 A1 9/2012 Abdallah  
 2012/0246450 A1 9/2012 Abdallah et al.  
 2012/0246657 A1 9/2012 Abdallah et al.  
 2012/0278593 A1 11/2012 Clark et al.  
 2013/0019047 A1 1/2013 Podvalny et al.  
 2013/0036296 A1 2/2013 Hickey et al.  
 2013/0046934 A1 2/2013 Nychka et al.  
 2013/0086417 A1 4/2013 Sivaramakrishnan et al.  
 2013/0097369 A1 4/2013 Talagala et al.  
 2013/0138888 A1 5/2013 Barreh et al.  
 2013/0238874 A1 9/2013 Avudaiyappan et al.  
 2013/0283286 A1 10/2013 Lee et al.  
 2013/0304991 A1 11/2013 Boettcher et al.  
 2013/0311759 A1 11/2013 Abdallah et al.  
 2013/0339671 A1 12/2013 Williams, III et al.  
 2013/0346699 A1 12/2013 Walker  
 2014/0032844 A1 1/2014 Avudaiyappan et al.  
 2014/0032845 A1 1/2014 Avudaiyappan et al.  
 2014/0032856 A1 1/2014 Avudaiyappan et al.  
 2014/0075168 A1 3/2014 Abdallah  
 2014/0108730 A1 4/2014 Avudaiyappan et al.  
 2014/0123145 A1 5/2014 Barrow-Williams et al.  
 2014/0156947 A1 6/2014 Avudaiyappan et al.  
 2014/0181833 A1 6/2014 Bird et al.  
 2014/0281242 A1 9/2014 Abdallah et al.  
 2014/0281411 A1 9/2014 Abdallah  
 2014/0281412 A1 9/2014 Abdallah et al.  
 2014/0281416 A1 9/2014 Abdallah et al.  
 2014/0281426 A1 9/2014 Abdallah et al.  
 2014/0281427 A1 9/2014 Abdallah  
 2014/0281428 A1 9/2014 Abdallah et al.  
 2014/0281436 A1 9/2014 Abdallah  
 2014/0282592 A1 9/2014 Abdallah et al.  
 2014/0282601 A1 9/2014 Abdallah et al.  
 2014/0317387 A1 10/2014 Abdallah et al.  
 2014/0344554 A1 11/2014 Abdallah  
 2014/0373022 A1 12/2014 Chan et al.  
 2015/0039859 A1 2/2015 Abdallah  
 2015/0046683 A1 2/2015 Abdallah  
 2015/0046686 A1 2/2015 Abdallah  
 2015/0186144 A1 7/2015 Abdallah et al.  
 2016/0041908 A1 2/2016 Avudaiyappan et al.  
 2016/0041913 A1 2/2016 Avudaiyappan et al.  
 2016/0041930 A1 2/2016 Avudaiyappan

2016/0154653 A1 6/2016 Abdallah et al.  
 2016/0210145 A1 7/2016 Abdallah et al.  
 2016/0210176 A1 7/2016 Abdallah et al.  
 2016/0371188 A1 12/2016 Abdallah et al.

## FOREIGN PATENT DOCUMENTS

CN 1305150 A 7/2001  
 CN 1451115 A 10/2003  
 CN 1613056 A 5/2005  
 CN 1214666 C 8/2005  
 CN 1650260 A 8/2005  
 CN 1713137 A 12/2005  
 CN 1774709 A 5/2006  
 CN 1841314 A 10/2006  
 CN 1841332 A 10/2006  
 CN 1848095 A 10/2006  
 CN 1881223 A 12/2006  
 CN 101114218 A 1/2008  
 CN 101151594 A 3/2008  
 CN 101231585 A 7/2008  
 CN 101241428 A 8/2008  
 CN 101263465 A 9/2008  
 CN 101313288 A 11/2008  
 CN 101344840 A 1/2009  
 CN 101449256 A 6/2009  
 CN 101582025 A 11/2009  
 CN 101627365 A 1/2010  
 CN 101763245 A 6/2010  
 CN 101916180 A 12/2010  
 CN 102105864 A 6/2011  
 EP 0596636 A2 5/1994  
 EP 0706133 A2 4/1996  
 EP 0813145 A2 12/1997  
 EP 2616928 A2 7/2013  
 GB 2343270 A 5/2000  
 GB 2452316 A 3/2009  
 JP 2000330790 A 11/2000  
 JP 2010-226275 A 10/2010  
 KR 20010050794 A 6/2001  
 KR 20010053622 6/2001  
 KR 20100003309 A 1/2010  
 TW 200707284 3/1995  
 TW 539996 B 7/2003  
 TW 544626 B 8/2003  
 TW 200401187 A 1/2004  
 TW 200405201 A 4/2004  
 TW 591530 B 6/2004  
 TW 200422949 A 11/2004  
 TW 1233545 B 6/2005  
 TW 1281121 B 5/2007  
 TW 200813766 A 3/2008  
 TW 200844853 A 11/2008  
 TW 200941339 A 10/2009  
 TW 1315488 B 10/2009  
 TW 200949690 A 12/2009  
 TW 1329437 B 8/2010  
 TW 1331282 B 10/2010  
 TW 1352288 B 11/2011  
 TW 201227520 A 7/2012  
 TW 201241744 A 10/2012  
 TW 201305819 A 2/2013  
 WO 9750031 A1 12/1997  
 WO 9919793 A1 4/1999  
 WO 0125921 A1 4/2001  
 WO 03/58434 A1 7/2003  
 WO 2004114128 A2 12/2004  
 WO 2007027671 A2 3/2007  
 WO 2008021434 A1 2/2008  
 WO 2008061154 A2 5/2008  
 WO 2009012296 A2 1/2009  
 WO 2009101563 A1 8/2009  
 WO 2010049585 A1 5/2010

(56)

**References Cited**

## FOREIGN PATENT DOCUMENTS

WO 2012135031 A2 10/2012  
 WO 2012135050 A2 10/2012

## OTHER PUBLICATIONS

Decision to Grant a Patent from foreign counterpart Korean Patent Application No. 20137033566, dated Apr. 29, 2016, 2 pages.

Decision to Grant a Patent from foreign counterpart Korean Patent Application No. KR1020157029107, dated Apr. 25, 2017, 2 pages.  
 Examination Report for European Application No. 12763717, dated Nov. 28, 2016, 5 pages.

Extended European Search Report for Application No. 07811845.2, dated Nov. 2, 2009, 7 pages.

Extended European Search Report for Application No. 07864410, dated Feb. 19, 2010, 8 pages.

Extended European Search Report for Application No. 11876314.3, dated Jun. 14, 2016, 6 pages.

Extended European Search Report for Application No. 12150513, dated Jun. 19, 2012, 8 pages.

Extended European Search Report for Application No. 12174228, dated Oct. 16, 2012, 4 pages.

Extended European Search Report for Application No. 12174229, dated Jul. 4, 2014, 10 pages.

Extended European Search Report for Application No. 12788989, dated May 12, 2016, 9 pages.

Extended European Search Report for Application No. 12789667, dated Feb. 26, 2016, 7 pages.

Extended European Search Report for Application No. 14769411.1, dated Apr. 5, 2017, 8 pages.

Extended European Search Report for Application No. 14769450.9, dated Feb. 21, 2017, 16 pages.

Extended European Search Report for Application No. 14770976.0, dated Jul. 3, 2017, 9 pages.

Extended European Search Report for Application No. 16196777.3, dated Mar. 20, 2017, 6 pages.

Extended European Search Report for Application No. EP11826042, dated Jan. 24, 2014, 6 pages.

Extended European Search Report for Application No. EP11876128, dated Jun. 21, 2016, 8 pages.

Extended European Search Report for Application No. EP11876130, dated Jun. 1, 2016, 7 pages.

Extended European Search Report for Application No. EP12763717, dated Sep. 24, 2014, 5 pages.

Extended European Search Report for Application No. EP12764627, dated Jul. 10, 2014, 5 pages.

Extended European Search Report for Application No. EP12764838, dated Jul. 10, 2014, 5 pages.

Final Office Action from U.S. Appl. No. 12/296,919, dated Jun. 14, 2011, 7 pages.

Final Office Action from U.S. Appl. No. 12/296,919, dated Oct. 22, 2010, 7 pages.

Final Office Action from U.S. Appl. No. 12/514,303, dated Jan. 24, 2013, 11 pages.

Final Office Action from U.S. Appl. No. 13/428,438, dated Dec. 24, 2014, 17 pages.

Final Office Action from U.S. Appl. No. 13/428,440, dated Dec. 24, 2014, 19 pages.

Final Office Action from U.S. Appl. No. 13/428,452, dated Dec. 24, 2014, 20 pages.

Final Office Action from U.S. Appl. No. 13/475,708, dated Jun. 9, 2016, 35 pages.

Final Office Action from U.S. Appl. No. 13/475,708, dated May 8, 2015, 23 pages.

Final Office Action from U.S. Appl. No. 13/475,739, dated Feb. 4, 2015, 12 pages.

Final Office Action from U.S. Appl. No. 13/475,739, dated Nov. 23, 2015, 28 pages.

Final Office Action from U.S. Appl. No. 14/194,589, dated Apr. 19, 2016, 7 pages.

Final Office Action from U.S. Appl. No. 14/212,203, dated Dec. 13, 2016, 20 pages.

Final Office Action from U.S. Appl. No. 14/212,203, dated Sep. 12, 2017, 84 pages.

Final Office Action from U.S. Appl. No. 14/212,533, dated Jan. 4, 2017, 27 pages.

Final Office Action from U.S. Appl. No. 14/212,533, dated Sep. 8, 2017, 69 pages.

Final Office Action from U.S. Appl. No. 14/213,115, dated Feb. 3, 2015, 11 pages.

Final Office Action from U.S. Appl. No. 14/213,115, dated Mar. 7, 2016, 18 pages.

Final Office Action from U.S. Appl. No. 14/213,135, dated Oct. 26, 2015, 20 pages.

Final Office Action from U.S. Appl. No. 14/213,218, dated Jul. 6, 2016, 24 pages.

Final Office Action from U.S. Appl. No. 14/213,218, dated Jul. 22, 2015, 16 pages.

Final Office Action from U.S. Appl. No. 14/213,692, dated Jan. 20, 2016, 18 pages.

Final Office Action from U.S. Appl. No. 14/213,730, dated May 11, 2016, 14 pages.

Final Office Action from U.S. Appl. No. 14/213,854, dated Nov. 9, 2015, 19 pages.

Final Office Action from U.S. Appl. No. 14/214,045, dated Aug. 29, 2016, 14 pages.

Final Office Action from U.S. Appl. No. 14/214,176, dated Aug. 29, 2016, 17 pages.

Final Office Action from U.S. Appl. No. 14/214,280, dated Mar. 6, 2017, 12 pages.

Final Office Action from U.S. Appl. No. 14/214,280, dated Mar. 11, 2016, 18 pages.

Final Office Action from U.S. Appl. No. 14/214,280, dated Oct. 24, 2016, 20 pages.

Decision on Reexamination, CN App. No. 201480024832.5, dated Feb. 21, 2020, 2 pages (1 page of English Translation and 1 page of Office Action).

Examination Report, IN App. No. 2195/CHENP/2013, dated Jul. 18, 2019, 6 pages.

Examination Report, IN App. No. 5551/CHENP/2015, dated Jan. 20, 2020, 6 pages.

Examination Report, IN App. No. 7383/CHENP/2013, dated Aug. 5, 2019, 6 pages.

First Office Action, CN App. No. 201710264673.1, dated Jan. 9, 2020, 15 pages (8 pages of English Translation and 7 pages of Office Action).

First Office Action, CN App. No. 201710764883.7, dated Nov. 27, 2019, 11 pages (5 pages of English Translation and 6 pages of Office Action).

First Office Action, IN App. No. 3611/CHENP/2014, dated Nov. 26, 2019, pp. 1-8.

First Office Action, IN App. No. 5509/CHENP/2015, dated Jan. 16, 2020, pp. 1-6.

First Office Action, IN App. No. 7466/CHENP/2013, dated Nov. 18, 2019, pp. 1-7.

Grant of Patent, KR App. No. 10-2017-7020829, dated Nov. 25, 2019, 3 pages (1 page of English Translation and 2 pages of Office Action).

Intention to Grant, EP App. No. 11876130.3, dated Jan. 14, 2020, pp. 1-60.

Intention to Grant, EP App. No. 11876314.3, dated Dec. 2, 2019, 5 pages.

Intention to Grant, EP App. No. 16196777.3, dated Dec. 9, 2019, pp. 1-7.

Notice of Allowance, U.S. App. No. 15/944,655, dated Dec. 17, 2019, 5 pages.

Office Action, IN App. No. 9176/CHENP/2013, dated Aug. 20, 2019, pp. 1-9.

Office Action, IN App. No. 9177/CHENP/2013, dated Nov. 15, 2019, pp. 1-9.

(56)

**References Cited**

## OTHER PUBLICATIONS

- Search Report, CN App. No. 201180076245.7, dated Mar. 7, 2016, 1 page.
- Abandonment from U.S. Appl. No. 13/824,013, mailed Mar. 3, 2015, 1 page.
- Abandonment from U.S. Appl. No. 14/212,203, mailed Jul. 26, 2018, 2 pages.
- Abandonment from U.S. Appl. No. 14/212,533, mailed Jun. 19, 2018, 3 pages.
- Abandonment from U.S. Appl. No. 14/360,282, mailed May 25, 2018, 2 pages.
- Abandonment from U.S. Appl. No. 15/354,857, mailed Jul. 30, 2018, 2 pages.
- Advisory Action from U.S. Appl. No. 12/296,919, dated Aug. 26, 2011, 3 pages.
- Advisory Action from U.S. Appl. No. 14/212,203, dated Apr. 5, 2018, 8 pages.
- Advisory Action from U.S. Appl. No. 14/214,280, dated May 15, 2017, 3 pages.
- Advisory Action from U.S. Appl. No. 14/360,282, dated Jan. 23, 2018, 2 pages.
- Communication pursuant to Article 94(3) EPC for Application No. 14770976.0, dated Feb. 18, 2019, 4 pages.
- Communication pursuant to Article 94(3) EPC for Application No. 12174229.0, dated Dec. 20, 2018, 5 pages.
- Communication Pursuant to Article 94(3) EPC for Application No. 12763717.1, dated Mar. 22, 2019, 7 pages.
- Communication pursuant to Article 94(3) EPC for Application No. 14769411.1, dated Dec. 7, 2018, 7 pages.
- Communication pursuant to Article 94(3) EPC for Application No. 14770976.0, dated Mar. 16, 2018, 4 pages.
- Communication pursuant to Article 94(3) EPC for Application No. 11876128.7, dated Feb. 5, 2018, 9 pages.
- Communication pursuant to Article 94(3) EPC for Application No. 11876130.3, dated Feb. 5, 2018, 9 pages.
- Communication pursuant to Article 94(3) EPC for Application No. 11876130.3, dated Jan. 15, 2019, 11 pages.
- Communication pursuant to Article 94(3) EPC for Application No. 11876130.3, dated Oct. 29, 2018, 7 pages.
- Communication pursuant to Article 94(3) EPC for Application No. 11876314.3, dated Feb. 5, 2018, 8 pages.
- Communication pursuant to Article 94(3) EPC for Application No. 11876314.3, dated Oct. 19, 2018, 5 pages.
- Communication pursuant to Article 94(3) EPC for Application No. 11876314.3, dated Sep. 24, 2018, 6 pages.
- Communication pursuant to Article 94(3) EPC for Application No. 12789667.8, dated Feb. 21, 2018, 4 pages.
- Communication pursuant to Article 94(3) EPC for European Application No. 070864410, dated Mar. 16, 2012, 4 pages.
- Communication pursuant to Article 94(3) EPC for European Application No. 070864410, dated Nov. 14, 2012, 4 pages.
- Communication pursuant to Article 94(3) EPC for European Application No. 07811845, dated Apr. 16, 2014, 5 pages.
- Communication pursuant to Article 94(3) EPC for European Application No. 07811845, dated Dec. 21, 2015, 3 pages.
- Communication pursuant to Article 94(3) EPC for European Application No. 07811845, dated Feb. 3, 2014, 5 pages.
- Communication pursuant to Article 94(3) EPC for European Application No. 07811845, dated Feb. 16, 2011, 6 pages.
- Communication pursuant to Article 94(3) EPC for European Application No. 07811845, dated Jan. 27, 2012, 7 pages.
- Communication pursuant to Article 94(3) EPC for European Application No. 12150513, dated Apr. 16, 2013, 5 pages.
- Communication pursuant to Article 94(3) EPC for European Application No. 12150513, dated Dec. 21, 2015, 4 pages.
- Communication pursuant to Article 94(3) EPC for European Application No. 12150513, dated May 9, 2014, 8 pages.
- Communication pursuant to Article 94(3) EPC for European Application No. 12174228, dated Jun. 11, 2013, 3 pages.
- Communication pursuant to Article 94(3) EPC for European Application No. 12764627, dated Oct. 4, 2016, 4 pages.
- Communication pursuant to Article 94(3) EPC for European Application No. 12788989.7, dated Jun. 22, 2017, 6 pages.
- Communication pursuant to Article 94(3) EPC, for European Application No. 16196777.3, dated Feb. 28, 2019, 5 pages.
- Communication pursuant to Rules 161(2) and 162 EPC for Application No. 12763717, dated Nov. 22, 2013, 3 pages.
- Communication pursuant to Rules 70(2) and 70a(2) EPC for Application No. 12763717, dated Oct. 10, 2014, 1 page.
- Communication pursuant to Rules 70(2) and 70a(2) EPC for European Application No. 11876314.3, dated Jul. 1, 2016, 1 page.
- Cooperman, "Cache Basics," Winter 2003, downloaded from <http://www.ccs.neu.edu/course/com3200/parent/NOTES/cache-basics.html> on Sep. 24, 2015, 3 pages. (no publication month available).
- Corrected Notice of Allowance from U.S. Appl. No. 13/475,708, dated Feb. 14, 2018, 27 pages.
- Corrected Notice of Allowance from U.S. Appl. No. 13/475,708, dated Feb. 26, 2018, 31 pages.
- Corrected Notice of Allowance from U.S. Appl. No. 15/219,063, dated Jun. 28, 2018, 8 pages.
- Corrected Notice of Allowance from U.S. Appl. No. 15/357,943, dated Apr. 2, 2018, 4 pages.
- Decision to Grant a Patent for European Application No. 07811845, dated Jun. 16, 2016, 2 pages.
- Decision to Grant a Patent for European Application No. 12150513, dated Jun. 16, 2016, 2 pages.
- Decision to Grant a Patent for European Application No. 12174228, dated Dec. 13, 2013, 5 pages.
- Decision to Grant a Patent for Korean Application No. KR1020137027843, dated Apr. 29, 2016, 2 pages.
- Decision to Grant a Patent for Korean Patent Application No. 20137027842, dated Mar. 31, 2016, 2 pages.
- Decision to grant a patent from foreign counterpart Korean Patent Application No. 10-2014-7016774, dated Jul. 25, 2016, 2 pages.
- Communication pursuant to Article 94(3) EPC, EPApp. No. 12764627.1, dated Feb. 25, 2020, 5 pages.
- Communication pursuant to Article 94(3) EPC, EPApp. No. 12764838.4, dated Feb. 25, 2020, 5 pages.
- Non-Final Office Action, U.S. Appl. No. 15/408,323, dated Feb. 25, 2020, 9 pages.
- Notice of Allowance, U.S. Appl. No. 16/166,010, dated Mar. 18, 2020, 9 pages.
- Office Action, IN App No. 5500/CHENP/2015, dated Feb. 18, 2020, 6 pages.
- Rotenberg E., et al., "Trace Cache: a Low Latency Approach to High Bandwidth Instruction Fetching," Apr. 11, 1996, pp. 1-48.
- Notice of Allowance from U.S. Appl. No. 15/019,920, dated Jul. 14, 2017, 100 pages.
- Notice of Allowance from U.S. Appl. No. 15/082,359, dated Mar. 21, 2018, 9 pages.
- Notice of Allowance from U.S. Appl. No. 15/082,867, dated Dec. 22, 2017, 25 pages.
- Notice of Allowance from U.S. Appl. No. 15/082,867, dated Jul. 7, 2017, 98 pages.
- Notice of Allowance from U.S. Appl. No. 15/219,063, dated Mar. 19, 2018, 28 pages.
- Notice of Allowance from U.S. Appl. No. 15/257,593, dated Oct. 11, 2017, 95 pages.
- Notice of Allowance from U.S. Appl. No. 15/357,943, dated Jan. 16, 2018, 16 pages.
- Notice of Allowance from U.S. Appl. No. 15/408,255, dated Jul. 25, 2018, 136 pages.
- Notice of Allowance from U.S. Appl. No. 15/408,269, dated Sep. 24, 2018, 137 pages.
- Notice of Allowance from U.S. Appl. No. 15/706,056, dated Dec. 28, 2018, 138 pages.
- Notice of Allowance from U.S. Appl. No. 15/354,742, dated Mar. 26, 2019, 24 pages.
- Notice of Final Rejection from foreign counterpart Korean Patent Application No. 10-2015-7029262, dated May 23, 2017, 7 pages.

(56)

**References Cited**

## OTHER PUBLICATIONS

Notice of Preliminary Rejection from foreign counterpart Korean Patent Application No. 10-2016-7017150, dated Apr. 20, 2017, 5 pages.

Notice of Preliminary Rejection from foreign counterpart Korean Patent Application No. 10-2018-7003058, dated Jun. 4, 2018, 10 pages.

Notice on Grant of Patent Right for Invention from foreign counterpart China Application No. 201180076244.2, dated Aug. 28, 2017, 4 pages.

Notice on Grant of Patent Right for Invention from foreign counterpart Chinese Patent Application No. 201180076248.0, dated Feb. 27, 2018, 6 pages.

Notice on Grant of Patent Right for Invention from foreign counterpart Chinese Patent Application No. 201280024012, dated Mar. 12, 2018, 4 pages.

Notice on Grant of Patent Right for Invention from foreign counterpart Chinese Patent Application No. 201280024054.0, dated Dec. 1, 2017, 4 pages.

Notice on Grant of Patent Right for Invention from foreign counterpart Chinese Patent Application No. 201280024095.X, dated Nov. 7, 2017, 6 pages.

Notification of Reason for Refusal from Foreign Counterpart Korean Patent Application No. 10-2013-7027842, dated Sep. 18, 2015, 7 pages.

Notification of Reason for Refusal from foreign counterpart Korean Patent Application No. 10-2014-7016774, dated Jan. 28, 2016, 4 pages.

Notification of Reason for Refusal from foreign counterpart Korean Patent Application No. 10-2015-7029262, dated Oct. 17, 2016, 12 pages.

Notification of Reason for Refusal from foreign counterpart Korean Patent Application No. 10-2017-7002379, dated May 26, 2017, 6 pages.

Notification of Reason for Refusal from foreign counterpart Korean Patent Application No. 10-2017-7002473, dated May 26, 2017, 7 pages.

Notification of Reason for Refusal from foreign counterpart Korean Patent Application No. 20137027841, dated Sep. 18, 2015, 10 pages.

Notification of Reason for Refusal from foreign counterpart Korean Patent Application No. 20137033565, dated Sep. 30, 2015, 6 pages.

Notification of Reason for Refusal from foreign counterpart Korean Patent Application No. 20137033566, dated Sep. 30, 2015, 9 pages.

Notification of Reason for Refusal from foreign counterpart Korean Patent Application No. KR1020137027843, dated Sep. 30, 2015, 8 pages.

Notification of Reason for Refusal from foreign counterpart Korean Patent Application No. KR1020157029107, dated Oct. 13, 2016, 11 pages.

Notification of Reason for Refusal from Korean Application No. 10-2014-7016763, dated Apr. 29, 2016, 11 pages.

Notification of Reason for Refusal from Korean Application No. 10-2015-7028745, dated May 23, 2016, 8 pages.

Notification to Grant Patent Right for Invention from foreign counterpart China Patent Application No. 201180076245.7, dated Nov. 2, 2016, 3 pages.

Notification to Grant Patent Right for Invention from foreign counterpart China Patent Application No. CN201280034725, dated Aug. 12, 2016, 3 pages.

Notification to Grant Patent Right for Invention from foreign counterpart China Patent Application No. CN201310589048, dated May 5, 2016, 3 pages.

Office Action and Search Report from foreign counterpart Taiwan Patent Application No. 100142885, dated Jan. 23, 2017, 12 pages.

Office Action and Search Report from foreign counterpart Taiwan Patent Application No. 101117854, dated Mar. 30, 2017, 7 pages.

Office Action and Search Report from foreign counterpart Taiwan Patent Application No. 106127331, dated Nov. 23, 2018, 13 pages.

Office Action from foreign counterpart Chinese Patent Application No. 200780046679, dated May 21, 2013, 14 pages.

Office Action from foreign counterpart Chinese patent application No. 201280024012, dated Feb. 3, 2017, 20 pages.

Office Action from foreign counterpart Chinese patent application No. 201280024095, dated Feb. 4, 2017, 31 pages.

Office Action from foreign counterpart European Patent Application No. EP12764838, dated Oct. 4, 2016, 4 pages.

Office Action from foreign counterpart Taiwan Patent Application No. 20140109479, dated Nov. 28, 2016, 7 pages.

Partial European Search Report for Application No. 12174229, dated Oct. 10, 2012, 7 pages.

Partial Supplementary European Search Report for Application No. 14769450.9, dated Oct. 11, 2016, 8 pages.

Partial Supplementary European Search Report for Application No. EP14770976.0, dated Mar. 24, 2017, 7 pages.

Restriction Requirement from U.S. Appl. No. 12/296,919, dated Feb. 8, 2011, 4 pages.

Restriction Requirement from U.S. Appl. No. 12/514,303, dated Oct. 15, 2012, 4 pages.

Restriction Requirement from U.S. Appl. No. 14/360,282, dated Jul. 28, 2016, 4 pages.

Search Report for Chinese Application No. CN201280024012, dated May 19, 2016, 2 pages.

Second Office Action from foreign counterpart Chinese Patent Application No. 201480024528.0, dated Oct. 8, 2018, 7 pages.

Final Office Action from U.S. Appl. No. 14/216,493, dated Aug. 30, 2016, 21 pages.

Final Office Action from U.S. Appl. No. 14/216,493, dated May 22, 2017, 17 pages.

Final Office Action from U.S. Appl. No. 14/216,859, dated Jun. 9, 2016, 16 pages.

Final Office Action from U.S. Appl. No. 14/360,280, dated Aug. 10, 2017, 103 pages.

Final Office Action from U.S. Appl. No. 14/360,280, dated Jul. 24, 2018, 24 pages.

Final Office Action from U.S. Appl. No. 14/360,282, dated Feb. 16, 2017, 10 pages.

Final Office Action from U.S. Appl. No. 14/360,282, dated Oct. 4, 2017, 22 pages.

Final Office Action from U.S. Appl. No. 14/360,284, dated Mar. 1, 2017, 10 pages.

Final Office Action from U.S. Appl. No. 15/082,359, dated Jan. 31, 2018, 22 pages.

Final Office Action from U.S. Appl. No. 15/219,063, dated Nov. 20, 2017, 27 pages.

Final Office Action from U.S. Appl. No. 15/354,742, dated Nov. 29, 2017, 20 pages.

Final Office Action from U.S. Appl. No. 15/354,857, dated Nov. 28, 2017, 23 pages.

Final Office Action from U.S. Appl. No. 15/408,323, dated Feb. 28, 2019, 18 pages.

First Examination Report from foreign counterpart Indian Patent Application No. 51/KOLNP/2012, dated Jul. 30, 2018, 7 pages.

First Office Action and Search report from foreign counterpart China Patent Application No. 201180076248.0, dated Mar. 17, 2016, 25 pages.

First Office Action and Search Report from foreign counterpart China Patent Application No. 201480024463.X, dated Apr. 1, 2017, 31 pages. (Translation available only for office action).

First Office Action and Search report from foreign counterpart Chinese Patent Application No. 201180076244.2, dated Mar. 22, 2016, 18 pages (Translation available only for Office Action).

First Office Action and Search Report from foreign counterpart Chinese Patent Application No. 201480024528.0, dated Jan. 26, 2018, 19 pages.(Translation available only for office action).

First Office Action and Search Report from foreign counterpart Chinese Patent Application No. 201480024832.5, dated Feb. 6, 2018, 15 pages. (Translation available only for office action).

First Office Action from foreign counterpart China Patent Application No. 201180076245.7, dated Mar. 21, 2016, 10 pages.

First Office Action from foreign counterpart China Patent Application No. 201280024012.7, dated May 30, 2016, 21 pages.



(56)

**References Cited**

## OTHER PUBLICATIONS

First Office Action from foreign counterpart China Patent Application No. CN201280034725, dated Oct. 26, 2015, 26 pages.

First Office Action from foreign counterpart China Patent Application No. CN201280034739, dated Nov. 3, 2015, 39 pages.

First Office Action from foreign counterpart China Patent Application No. CN201310589048, dated Feb. 2, 2016, 8 pages.

First Office Action from foreign counterpart Chinese Patent Application No. 201280024054.0, dated May 30, 2016, 24 pages.

First Office Action from foreign counterpart Chinese patent application No. 201280024095, dated May 26, 2016, 32 pages.

Fourth Office Action and Search report from foreign counterpart China Patent Application No. 201180076248.0, dated Nov. 9, 2017, 38 pages. (Translation available only for office action).

Garmany J., "The Power of Indexing: Oracle Tips by Burleson Consulting," Burleson Enterprises, Inc., archived on Mar. 9, 2009, retrieved Sep. 17, 2015 via Internet: [web.archive.org/web/20090309201136/http://dba-oracle.com/t\\_indexing\\_power.htm](http://web.archive.org/web/20090309201136/http://dba-oracle.com/t_indexing_power.htm), 7 pages.

Grant of Patent for Korean Application No. 10-2014-7016763, dated Oct. 31, 2016, 2 pages.

Grant of Patent for Korean Application No. 10-2015-7028745, dated Nov. 30, 2016, 2 pages.

Intel "Programming on Intel® Platform," The edition team of Intel® Software College course book, Shanghai Jiao Tong University Press, published Jan. 31, 2011, pp. 175-180.

Intention to Grant a patent for European Application No. 07811845, dated Mar. 31, 2016, 58 pages.

Intention to Grant a patent for European Application No. 12150513, dated Mar. 15, 2016, 59 pages.

Intention to grant from foreign counterpart European Patent Application No. 12788989.7, dated Feb. 23, 2018, 47 pages.

International Preliminary Report on Patentability and for Application No. PCT/US2007/084710, dated May 19, 2009, 4 pages.

International Preliminary Report on Patentability and Written Opinion for Application No. PCT/US2007/066536, dated Oct. 14, 2008, 6 pages.

International Preliminary Report on Patentability and Written Opinion for Application No. PCT/US2012/038711, dated Nov. 20, 2013, 5 pages.

International Preliminary Report on Patentability and Written Opinion for Application No. PCT/US2012/038713, dated Nov. 20, 2013, 5 pages.

International Preliminary Report on Patentability for Application No. PCT/US2011/051992, dated Mar. 28, 2013, 8 pages.

International Preliminary Report on Patentability for Application No. PCT/US2011/061940, dated Jun. 5, 2014, 6 pages.

International Preliminary Report on Patentability for Application No. PCT/US2011/061953, dated Jun. 5, 2014, 7 pages.

International Preliminary Report on Patentability for Application No. PCT/US2011/061957, dated Jun. 5, 2014, 7 pages.

International Preliminary Report on Patentability for Application No. PCT/US2012/030383, dated Oct. 10, 2013, 6 pages.

International Preliminary Report on Patentability for Application No. PCT/US2012/030409, dated Oct. 10, 2013, 6 pages.

International Preliminary Report on Patentability for Application No. PCT/US2012/30360, dated Oct. 10, 2013, 6 pages.

International Preliminary Report on Patentability for Application No. PCT/US2014/024276, dated Sep. 24, 2015, 6 pages.

International Preliminary Report on Patentability for Application No. PCT/US2014/024608, dated Sep. 24, 2015, 8 pages.

International Preliminary Report on Patentability for Application No. PCT/US2014/024677, dated Sep. 24, 2015, 7 pages.

International Preliminary Report on Patentability for Application No. PCT/US2014/024722, dated Sep. 24, 2015, 6 pages.

International Preliminary Report on Patentability for Application No. PCT/US2014/024775, dated Sep. 24, 2015, 6 pages.

Notice of Allowance from U.S. Appl. No. 13/428,438, dated Apr. 13, 2017, 52 pages.

Notice of Allowance from U.S. Appl. No. 13/428,438, dated Aug. 7, 2017, 42 pages.

Notice of Allowance from U.S. Appl. No. 13/428,438, dated Aug. 10, 2016, 9 pages.

Notice of Allowance from U.S. Appl. No. 13/428,438, dated Dec. 29, 2016, 9 pages.

Notice of Allowance from U.S. Appl. No. 13/428,438, dated Mar. 4, 2016, 14 pages.

Notice of Allowance from U.S. Appl. No. 13/428,438, dated Nov. 6, 2015, 9 pages.

Notice of Allowance from U.S. Appl. No. 13/428,440, dated Apr. 20, 2017, 16 pages.

Notice of Allowance from U.S. Appl. No. 13/428,440, dated Feb. 26, 2016, 10 pages.

Notice of Allowance from U.S. Appl. No. 13/428,440, dated Mar. 10, 2017, 52 pages.

Notice of Allowance from U.S. Appl. No. 13/428,440, dated Nov. 16, 2016, 9 pages.

Notice of Allowance from U.S. Appl. No. 13/428,440, dated Nov. 20, 2015, 9 pages.

Notice of Allowance from U.S. Appl. No. 13/428,452, dated Oct. 21, 2015, 9 pages.

Notice of Allowance from U.S. Appl. No. 13/475,708, dated Jun. 16, 2017, 51 pages.

Notice of Allowance from U.S. Appl. No. 13/475,708, dated Jun. 30, 2017, 53 pages.

Notice of Allowance from U.S. Appl. No. 13/475,708, dated Mar. 17, 2017, 55 pages.

Notice of Allowance from U.S. Appl. No. 13/475,708, dated Nov. 27, 2017, 24 pages.

Notice of Allowance from U.S. Appl. No. 13/475,708, dated Oct. 13, 2016, 17 pages.

Notice of Allowance from U.S. Appl. No. 13/475,739, dated Aug. 3, 2016, 11 pages.

Notice of Allowance from U.S. Appl. No. 13/475,739, dated Mar. 25, 2016, 25 pages.

Notice of Allowance from U.S. Appl. No. 13/691,609, dated Aug. 36, 2014, 11 pages.

Notice of Allowance from U.S. Appl. No. 13/691,609, dated Feb. 23, 2015, 16 pages.

Notice of Allowance from U.S. Appl. No. 13/824,013, dated Jul. 23, 2018, 15 pages.

Notice of Allowance from U.S. Appl. No. 14/194,589, dated Jul. 27, 2016, 7 pages.

Notice of Allowance from U.S. Appl. No. 14/213,115, dated Jun. 27, 2016, 9 pages.

Notice of Allowance from U.S. Appl. No. 14/213,115, dated Oct. 3, 2016, 20 pages.

Notice of Allowance from U.S. Appl. No. 14/213,135, dated Aug. 3, 2017, 103 pages.

Notice of Allowance from U.S. Appl. No. 14/213,135, dated Oct. 17, 2016, 17 pages.

Notice of Allowance from U.S. Appl. No. 14/213,218, dated Jun. 16, 2017, 89 pages.

Notice of Allowance from U.S. Appl. No. 14/213,692, dated Dec. 23, 2016, 19 pages.

Notice of Allowance from U.S. Appl. No. 14/213,692, dated Sep. 28, 2017, 112 pages.

Notice of Allowance from U.S. Appl. No. 14/213,730, dated Aug. 31, 2017, 96 pages.

Notice of Allowance from U.S. Appl. No. 14/213,730, dated Oct. 27, 2016, 16 pages.

Notice of Allowance from U.S. Appl. No. 14/213,854, dated Oct. 7, 2016, 19 pages.

Notice of Allowance from U.S. Appl. No. 14/214,045, dated Apr. 18, 2017, 88 pages.

Notice of Allowance from U.S. Appl. No. 14/214,045, dated Oct. 6, 2017, 137 pages.

Notice of Allowance from U.S. Appl. No. 14/214,176, dated May 10, 2017, 88 pages.

Notice of Allowance from U.S. Appl. No. 14/214,176, dated Oct. 19, 2017, 25 pages.

Notice of Allowance from U.S. Appl. No. 14/214,280, dated Jun. 29, 2017, 86 pages.

(56)

**References Cited**

## OTHER PUBLICATIONS

- Notice of Allowance from U.S. Appl. No. 14/215,633, dated Jun. 30, 2017, 83 pages.
- Notice of Allowance from U.S. Appl. No. 14/215,633, dated Mar. 23, 2017, 17 pages.
- Notice of Allowance from U.S. Appl. No. 14/215,633, dated May 23, 2016, 9 pages.
- Notice of Allowance from U.S. Appl. No. 14/215,633, dated Oct. 4, 2017, 15 pages.
- Notice of Allowance from U.S. Appl. No. 14/215,633, dated Sep. 29, 2016, 13 pages.
- Notice of Allowance from U.S. Appl. No. 14/216,493, dated Aug. 1, 2018, 14 pages.
- Notice of Allowance from U.S. Appl. No. 14/216,493, dated Aug. 4, 2017, 95 pages.
- Notice of Allowance from U.S. Appl. No. 14/216,859, dated Dec. 1, 2017, 113 pages.
- Notice of Allowance from U.S. Appl. No. 14/216,859, dated Jan. 24, 2017, 17 pages.
- Notice of Allowance from U.S. Appl. No. 14/360,284, dated Jun. 14, 2017, 100 pages.
- Notice of Allowance from U.S. Appl. No. 14/733,827, dated Sep. 22, 2017, 30 pages.
- Notice of Allowance from U.S. Appl. No. 15/019,920, dated Dec. 6, 2017, 24 pages.
- Second Office Action from foreign counterpart China Patent Application No. 201180076248.0, dated Oct. 20, 2016, 25 pages.
- Second Office Action from foreign counterpart China Patent Application No. 201480024463.X, dated Nov. 14, 2017, 34 pages.
- Second Office Action from foreign counterpart China Patent Application No. CN201280034725, dated Apr. 14, 2016, 8 pages.
- Second Office Action from foreign counterpart China Patent Application No. CN201280034739, dated Jun. 23, 2016, 44 pages.
- Second Office Action from foreign counterpart Chinese Patent Application No. 201280024054.0, dated Dec. 26, 2016, 11 pages.
- Second Office Action from foreign counterpart Chinese Patent Application No. 201480024832.5, dated Apr. 2, 2019, 10 pages.
- Second Office Action with search report from foreign counterpart Chinese Patent Application No. 201180076244, dated Nov. 18, 2016, 21 pages (Translation available only for Office Action).
- Summons to attend Oral Proceedings for European Application No. 070864410, mailed Apr. 3, 2013, 3 pages.
- Third Office Action and Search report from foreign counterpart China Patent Application No. 201180076248.0, dated May 2, 2017, 27 pages.
- Third Office Action from foreign counterpart China Patent Application No. 201280024054.0, dated Jul. 28, 2017, 8 pages.
- Third Office Action from foreign counterpart Chinese Patent Application No. 201180076244.2, dated May 2, 2017, 20 pages.
- Third Office Action from foreign counterpart Chinese Patent Application No. 201280024012.7, dated Nov. 6, 2017, 8 pages.
- Third Office Action from foreign counterpart Chinese Patent Application No. 201280034739, dated Dec. 27, 2016, 18 pages.
- Written Opinion for Application No. PCT/US2007/066536, dated Jul. 30, 2008, 5 pages.
- Ye, et al., "A New Recovery Mechanism in Superscalar Microprocessors by Recovering Critical Misprediction," IEICE Transactions on Fundamentals of Electronics, Communications and Computer Sciences, The Institute of Electronics, Information and Communication Engineers, Dec. 1, 2011, vol. E94-A (12), pp. 2639-2648.
- International Preliminary Report on Patentability for Application No. PCT/US2014/024828, dated Sep. 24, 2015, 8 pages.
- International Search Report and Written Opinion for Application No. PCT/US2007/084710, dated May 22, 2008, 6 pages.
- International Search Report and Written Opinion for Application No. PCT/US2011/051992, dated Mar. 28, 2012, 11 pages.
- International Search Report and Written Opinion for Application No. PCT/US2011/061940, dated Jul. 20, 2012, 8 pages.
- International Search Report and Written Opinion for Application No. PCT/US2011/061953, dated Jul. 24, 2012, 8 pages.
- International Search Report and Written Opinion for Application No. PCT/US2011/061957, dated Jul. 20, 2012, 8 pages.
- International Search Report and Written Opinion for Application No. PCT/US2012/030383, dated Oct. 25, 2012, 8 pages.
- International Search Report and Written Opinion for Application No. PCT/US2012/030409, dated Oct. 12, 2012, 7 pages.
- International Search Report and Written opinion for Application No. PCT/US2012/038711, dated Nov. 28, 2012, 7 pages.
- International Search Report and Written Opinion for Application No. PCT/US2012/038713, dated Oct. 29, 2012, 7 pages.
- International Search Report and Written Opinion for Application No. PCT/US2012/30360, dated Oct. 29, 2012, 7 pages.
- International Search Report and Written Opinion for Application No. PCT/US2014/024276, dated Jul. 31, 2014, 7 pages.
- International Search Report and Written Opinion for Application No. PCT/US2014/024608, dated Jul. 31, 2014, 9 pages.
- International Search Report and Written Opinion for Application No. PCT/US2014/024677, dated Jun. 30, 2014, 9 pages.
- International Search Report and Written Opinion for Application No. PCT/US2014/024722, dated Jun. 27, 2014, 7 pages.
- International Search Report and Written Opinion for Application No. PCT/US2014/024775, dated Jun. 2, 2014, 7 pages.
- International Search Report and Written Opinion for Application No. PCT/US2014/024828, dated Jul. 28, 2014, 9 pages.
- International Search Report for Application No. PCT/US2007/066536, dated Jul. 30, 2008, 2 pages.
- Non-Final Office Action from U.S. Appl. No. 15/354,742, dated Dec. 4, 2018, 54 pages.
- Non-Final Office Action from U.S. Appl. No. 15/283,836, dated Dec. 27, 2018, 150 pages.
- Non-Final Office Action from U.S. Appl. No. 15/408,323, dated Oct. 9, 2018, 144 pages.
- Non-Final Office Action from U.S. Appl. No. 15/853,323, dated Aug. 28, 2018, 115 pages.
- Non-Final Office Action from U.S. Appl. No. 12/296,919, dated Apr. 7, 2011, 8 pages.
- Non-Final Office Action from U.S. Appl. No. 12/296,919, dated Jun. 14, 2010, 7 pages.
- Non-Final Office Action from U.S. Appl. No. 12/296,919, dated Mar. 7, 2012, 7 pages.
- Non-Final Office Action from U.S. Appl. No. 12/514,303, dated Jun. 27, 2013, 7 pages.
- Non-Final Office Action from U.S. Appl. No. 12/514,303, dated May 10, 2012, 9 pages.
- Non-Final Office Action from U.S. Appl. No. 13/428,438, dated Apr. 24, 2014, 15 pages.
- Non-Final Office Action from U.S. Appl. No. 13/428,438, dated May 1, 2015, 12 pages.
- Non-Final Office Action from U.S. Appl. No. 13/428,440, dated Jun. 18, 2014, 16 pages.
- Non-Final Office Action from U.S. Appl. No. 13/428,440, dated May 4, 2015, 13 pages.
- Non-Final Office Action from U.S. Appl. No. 13/428,452, dated Apr. 23, 2015, 11 pages.
- Non-Final Office Action from U.S. Appl. No. 13/428,452, dated Apr. 28, 2014, 21 pages.
- Non-Final Office Action from U.S. Appl. No. 13/475,708, dated Feb. 11, 2015, 27 pages.
- Non-Final Office Action from U.S. Appl. No. 13/475,708, dated Feb. 12, 2016, 37 pages.
- Non-Final Office Action from U.S. Appl. No. 13/475,739, dated May 21, 2015, 14 pages.
- Non-Final Office Action from U.S. Appl. No. 13/475,739, dated Sep. 2, 2014, 15 pages.
- Non-Final Office Action from U.S. Appl. No. 13/691,609, dated Jan. 15, 2014, 5 pages.
- Non-Final Office Action from U.S. Appl. No. 13/691,609, dated Sep. 5, 2013, 11 pages.
- Non-Final Office Action from U.S. Appl. No. 13/824,013, dated Feb. 7, 2018, 141 pages.
- Non-Final Office Action from U.S. Appl. No. 14/194,589, dated Nov. 19, 2015, 12 pages.

(56)

**References Cited**

## OTHER PUBLICATIONS

- Non-Final Office Action from U.S. Appl. No. 14/212,203, dated Mar. 24, 2017, 68 pages.
- Non-Final Office Action from U.S. Appl. No. 14/212,203, dated Sep. 8, 2016, 52 pages.
- Non-Final Office Action from U.S. Appl. No. 14/212,533, dated Apr. 20, 2017, 116 pages.
- Non-Final Office Action from U.S. Appl. No. 14/212,533, dated Sep. 22, 2016, 52 pages.
- Non-Final Office Action from U.S. Appl. No. 14/213,115, dated Oct. 19, 2015, 24 pages.
- Non-Final Office Action from U.S. Appl. No. 14/213,115, dated Sep. 22, 2014, 19 pages.
- Non-Final Office Action from U.S. Appl. No. 14/213,135, dated May 14, 2015, 23 pages.
- Non-Final Office Action from U.S. Appl. No. 14/213,135, dated May 31, 2016, 14 pages.
- Non-Final Office Action from U.S. Appl. No. 14/213,218, dated Apr. 22, 2015, 22 pages.
- Non-Final Office Action from U.S. Appl. No. 14/213,218, dated Feb. 2, 2016, 17 pages.
- Non-final Office Action from U.S. Appl. No. 14/213,692, dated Aug. 24, 2015, 30 pages.
- Non-final Office Action from U.S. Appl. No. 14/213,692, dated Jun. 13, 2016, 17 pages.
- Non-Final Office Action from U.S. Appl. No. 14/213,730, dated Jan. 7, 2016, 27 pages.
- Non-Final Office Action from U.S. Appl. No. 14/213,854, dated Apr. 29, 2016, 13 pages.
- Non-Final Office Action from U.S. Appl. No. 14/213,854, dated Jun. 19, 2015, 23 pages.
- Non-Final Office Action from U.S. Appl. No. 14/214,045, dated Apr. 1, 2016, 61 pages.
- Non-Final Office Action from U.S. Appl. No. 14/214,045, dated Dec. 19, 2016, 88 pages.
- Non-Final Office Action from U.S. Appl. No. 14/214,176, dated Jan. 6, 2017, 36 pages.
- Non-Final Office Action from U.S. Appl. No. 14/214,176, dated Mar. 25, 2016, 25 pages.
- Non-Final Office Action from U.S. Appl. No. 14/214,280, dated Jan. 6, 2017, 14 pages.
- Non-Final Office Action from U.S. Appl. No. 14/214,280, dated Jun. 16, 2016, 12 pages.
- Non-Final Office Action from U.S. Appl. No. 14/214,280, dated Sep. 18, 2015, 18 pages.
- Non-Final Office Action from U.S. Appl. No. 14/215,633, dated Oct. 22, 2015, 18 pages.
- Non-final Office Action from U.S. Appl. No. 14/216,493, dated Apr. 4, 2016, 26 pages.
- Non-Final Office Action from U.S. Appl. No. 14/216,493, dated Mar. 29, 2017, 18 pages.
- Non-Final Office Action from U.S. Appl. No. 14/216,859, dated Jan. 28, 2016, 33 pages.
- Non-Final Office Action from U.S. Appl. No. 14/360,280, dated Dec. 14, 2017, 25 pages.
- Non-Final Office Action from U.S. Appl. No. 14/360,280, dated Feb. 23, 2017, 34 pages.
- Non-Final Office Action from U.S. Appl. No. 14/360,282, dated Jun. 22, 2017, 97 pages.
- Non-Final Office Action from U.S. Appl. No. 14/360,282, dated Oct. 21, 2016, 13 pages.
- Non-final Office Action from U.S. Appl. No. 14/360,284, dated Oct. 21, 2016, 32 pages.
- Non-Final Office Action from U.S. Appl. No. 14/733,827, dated Apr. 28, 2017, 99 pages.
- Non-Final Office Action from U.S. Appl. No. 15/082,359, dated Aug. 11, 2017, 108 pages.
- Non-Final Office Action from U.S. Appl. No. 15/219,063, dated May 30, 2017, 102 pages.
- Non-Final Office Action from U.S. Appl. No. 15/257,593, dated Apr. 7, 2017, 37 pages.
- Non-final Office Action from U.S. Appl. No. 15/354,742, dated Aug. 25, 2017, 152 pages.
- Non-Final Office Action from U.S. Appl. No. 15/354,857, dated Sep. 12, 2017, 111 pages.
- Non-final Office Action from U.S. Appl. No. 15/357,943, dated Aug. 25, 2017, 111 pages.
- Non-Final Office Action from U.S. Appl. No. 15/712,017, dated May 7, 2018, 127 pages.
- Non-Final Office Action from U.S. Appl. No. 15/862,496, dated Apr. 5, 2018, 151 pages.
- Non-Final Office Action from U.S. Appl. No. 15/866,323, dated Oct. 1, 2018, 121 pages.
- Notice of Allowance from U.S. Appl. No. 15/853,323, dated Jan. 15, 2019, 15 pages.
- Notice of Allowance from U.S. Appl. No. 15/862,496, dated Nov. 2, 2018, 23 pages.
- Notice of Allowance from U.S. Appl. No. 13/824,013, dated Nov. 13, 2018, 12 pages.
- Notice of Allowance from U.S. Appl. No. 14/213,135, dated Oct. 3, 2018, 34 pages.
- Notice of Allowance from U.S. Appl. No. 14/216,493, dated Apr. 2, 2018, 22 pages.
- Notice of Allowance from U.S. Appl. No. 14/360,284, dated Oct. 12, 2018, 45 pages.
- Notice of Allowance from U.S. Appl. No. 15/408,311, dated Aug. 28, 2018, 138 pages.
- Notice of Allowance from U.S. Appl. No. 15/712,017, dated Oct. 3, 2018, 16 pages.
- Notice of Allowance and Search Report from foreign counterpart Taiwan Patent Application No. 103109479, dated Nov. 30, 2017, 4 pages. (Translation available only for Search report).
- Notice of Allowance from foreign counterpart Chinese Patent Application No. 200780046679, dated Feb. 6, 2017, 8 pages.
- Notice of Allowance from foreign counterpart Korean Patent Application No. 10-2015-7029262, dated Aug. 31, 2017, 3 pages.
- Notice of Allowance from foreign counterpart Korean Patent Application No. 10-2016-7017150, dated Oct. 30, 2017, 3 pages.
- Notice of Allowance from foreign counterpart Korean Patent Application No. 10-2017-7002379, dated Dec. 20, 2017, 3 pages.
- Notice of Allowance from foreign counterpart Korean Patent Application No. 10-2017-7002473, dated Dec. 20, 2017, 6 pages.
- Notice of Allowance from foreign counterpart Korean Patent Application No. 10-2018-7003058, dated Dec. 31, 2018, 3 pages.
- Notice of Allowance from foreign counterpart Korean Patent Application No. 20137027841, dated Mar. 31, 2016, 2 pages.
- Notice of Allowance from U.S. Appl. No. 12/296,919, dated Jul. 27, 2012, 6 pages.
- Notice of Allowance from U.S. Appl. No. 12/514,303, dated Oct. 25, 2013, 12 pages.
- Barham, et al., "Xen and the Art of Virtualization," Proceedings of the ACM Symposium on Operating Systems Principles, XP002298786, Oct. 2003, pp. 164-177.
- Franklin, et al., "The Expandable Split Window Paradigm for Exploiting Fine-Grain Parallelism," ACM SIGARCH Computer Architecture News—Special Issue: Proceedings of the 19th annual international symposium on Computer architecture (ISCA '92), Association for Computing Machinery (ACM), New York, NY, vol. 20 (2), May, 1992, pp. 58-67.
- Hu, et al., "An Approach for Implementing Efficient Superscalar CISC Processors," High Performance Computer Architecture, 2006, Twelfth International Symposium on Austin, Texas Feb. 11-15, 2006, pp. 40-51.
- Jacobson, et al., "Path-based Next Trace Prediction," MICRO 30—Proceedings of the 30th Annual IEEE/ACM International Symposium on Microarchitecture, Dec. 1-3, 1997, IEEE Computer Society, Washington, D.C., 1997, pp. 14-23.
- Kozyrakis, et al., "A New Direction for Computer Architecture Research," Computer, IEEE Computer Society Press, Los Alamitos, CA, Nov. 1, 1998, vol. 31 (11), pp. 24-32.

(56)

**References Cited**

## OTHER PUBLICATIONS

Mogul, et al., "Potential Benefits of Delta Encoding and Data Compression for HTTP," Oct. 1, 1997, ACM, SIGCOMM '97, pp. 181-194.

Nagarajan, et al., "A Design Space Evaluation of Grid Processor Architectures," 34th ACM/IEEE International Symposium, Piscataway, NJ, Dec. 1-5, 2001, pp. 40-51.

Nanda, et al., "The Misprediction Recovery Cache," International Journal of Parallel Programming—Special issue: MICRO-29, 29th annual IEEE/ACM international symposium on microarchitecture, Plenum Press, New York, NY, Aug. 1998, vol. 26 (4), pp. 383-415.

Nuth, et al., "The Named-State Register File: Implementation and Performance," High-Performance Computer Architecture, First IEEE Symposium, Jan. 22-25, 1995, 10 pages.

Rixner, et al., "Register Organization for Media Processing," HPCA-6—Proceedings of the 6th International Symposium on High-Performance Computer Architecture, Jan. 8-12, 2000, IEEE, Toulouse, France, pp. 375-386.

Rotenberg, et al., "Trace Cache: a Low Latency Approach to High Bandwidth Instruction Fetching," Apr. 11, 1996, pp. 1-48.

Santos, et al., "The 2D-VLIW Architecture," Technical Report IC-06-006, Instituto de Computacao, Universidad Estadual de Caminas, Mar. 2006, 13 pages.

Sassone, et al., "Dynamic Strands: Collapsing Speculative Dependence Chains for Reducing Pipeline Communication," Microarchitecture, IEEE, 37th International Symposium on Portland, USA Dec. 4, 2004, pp. 7-17, Piscataway, NJ, USA.

Sun, et al., "Modeling of FPGA Local/Global Interconnect Resources and Derivation of Minimal Test Configuration," Proceedings of the 17th IEEE International Symposium on Defect and Fault Tolerance In VLSI Systems (DFT'02), IEEE Computer Society, Nov. 6-8, 2002, 9 pages.

Wallace, et al., "Multiple Branch and Block Prediction," Third International symposium on High-Performance Computer Architecture, IEEE, Feb. 1997, pp. 94-103.

Yeh, et al., "Increasing the Instruction Fetch Rate Via Multiple Branch Prediction and a Branch Address Cache," ICS 93, Proceedings of the 7th International Conference on Supercomputing, ACM, New York, NY, Jul. 19-23, 1993, pp. 67-76.

Final Office Action, U.S. Appl. No. 16/166,010, dated Nov. 19, 2019, pp. 1-24.

First Office Action, IN App. No. 7380/CHENP/2013, dated Jun. 27, 2019, pp. 1-6.

Abandonment from U.S. Appl. No. 14/360,280, dated Apr. 4, 2019, 2 pages.

Abandonment from U.S. Appl. No. 15/866,323, dated Apr. 29, 2019, 2 pages.

Advisory Action from U.S. Appl. No. 15/283,836, dated Jul. 29, 2019 2 pages.

Advisory Action from U.S. Appl. No. 15/408,323, dated May 20, 2019, 3 pages.

Allowance Decision of Examination from foreign counterpart Taiwan Patent Application No. 106127331, dated Apr. 9, 2019, 3 pages.

Communication Pursuant to Article 94(3) EPC for Application No. 14769450.9, dated May 17, 2019, 12 pages.

Corrected Notice of Allowance from U.S. Appl. No. 15/354,742, dated Jun. 21, 2019, 38 pages.

Corrected Notice of Allowance from U.S. Appl. No. 15/354,742, dated May 22, 2019, 32 pages.

Final Office Action from U.S. Appl. No. 15/283,836, dated May 7, 2019, 14 pages.

Final Office Action from U.S. Appl. No. 15/944,655, dated Sep. 27, 2019, 13 pages.

Non-Final Office Action from U.S. Appl. No. 15/806,189, dated May 1, 2019, 145 pages.

Non-Final Office Action from U.S. Appl. No. 15/944,655, dated May 15, 2019, pp. 1-135.

Non-Final Office Action from U.S. Appl. No. 16/166,010, dated Jul. 1, 2019, 97 pages.

Notice of Allowance from U.S. Appl. No. 15/283,836, dated Sep. 9, 2019, 5 pages.

Notice of Preliminary Rejection from foreign counterpart Korean Patent Application No. 10-2017-7003623, dated Mar. 29, 2019, 5 pages.

Notice of Reason for Refusal from Korean Patent Application No. KR20177020829, dated May 20, 2019, 11 pages.

Office Action from Indian Patent Application No. 3678/CHENP/2014, dated Mar. 11, 2019, 7 pages.

Requirement for Restriction/Election from U.S. Appl. No. 15/884,280, dated Jun. 17, 2019, 5 pages.

Communication pursuant to Article 94(3) EPC, EP Appl. No. 14769411.1, dated Oct. 8, 2019, 10 pages.

Communication pursuant to Article 94(3) EPC, EP Appl. No. 14769411.1, dated Dec. 7, 2018, 7 pages.

Decision on Rejection, CN Appl. No. 201480024832.5, dated Oct. 9, 2019, 7 pages.

Notice of Allowance, Korean Appl. No. 10-2017-7003623, dated Sep. 30, 2019, 3 pages (1 pages of English Translation and 2 pages of Office Action).

Notice of Allowance, U.S. Appl. No. 15/884,280, dated Oct. 23, 2019, 9 pages.

Communication pursuant to Article 94(3) EPC, EP App. No. 14769411.1, dated May 4, 2020, 5 pages.

Decision to Grant a Patent, EP App. No. 11876314.3, dated Apr. 17, 2020, 2 pages.

Decision to Grant a Patent, EP App. No. 16196777.3, dated Mar. 12, 2020, 2 pages.

Decision to Grant a Patent, EP. App. No. 11876130.3, dated May 28, 2020, 2 pages.

Decision to Grant, KR App No. 10-2013-7027842, dated Mar. 31, 2016, 2 pages (1 page of English Translation and 1 page of Original Document).

Notice of Allowance, CN App. No. 201710264673.1, dated Jul. 6, 2020, 4 pages (2 pages of English Translation and 2 pages of Original Document).

Second Office Action, CN No. 2017107648837, dated Aug. 17, 2020, 23 pages (13 pages of English Translation and 10 pages of Original Document).

Summons to Attend Oral Proceedings pursuant to Rule 115(1) EPC, EP App. No. 14769450.9, Jul. 21, 2020, 14 pages.

Third Office Action, CN No. 201480024832.5, dated Aug. 4, 2020, 10 pages (6 pages of English Translation and 4 pages of Original Document).

Intention to Grant, EP App. No. 12764627.1, dated Mar. 2, 2021, 62 pages.

Intention to Grant, EP App. No. 14769450.9, dated Jan. 26, 2021, 6 pages.

Non-Final Office Action, U.S. Appl. No. 16/733,193, dated Mar. 12, 2021, 6 pages.

Communication pursuant to Article 94(3) EPC, EP App. No. 14769411.1, dated Nov. 30, 2020, 9 pages.

Decision to grant a European patent dated Jan. 21, 2021 for EP Application No. 12789667.

Hearing Notice, IN App. No. 51/KOLNP/2012, Sep. 28, 2020, 4 pages.

Intention to Grant, EP App. No. 12789667.8, dated Nov. 17, 2020, 8 pages.

Notice on Grant of Patent Right for Invention, CN App. No. 201480024832.5, dated Nov. 27, 2020, 4 pages (2 pages of English Translation and 2 pages of Original Document).

\* cited by examiner

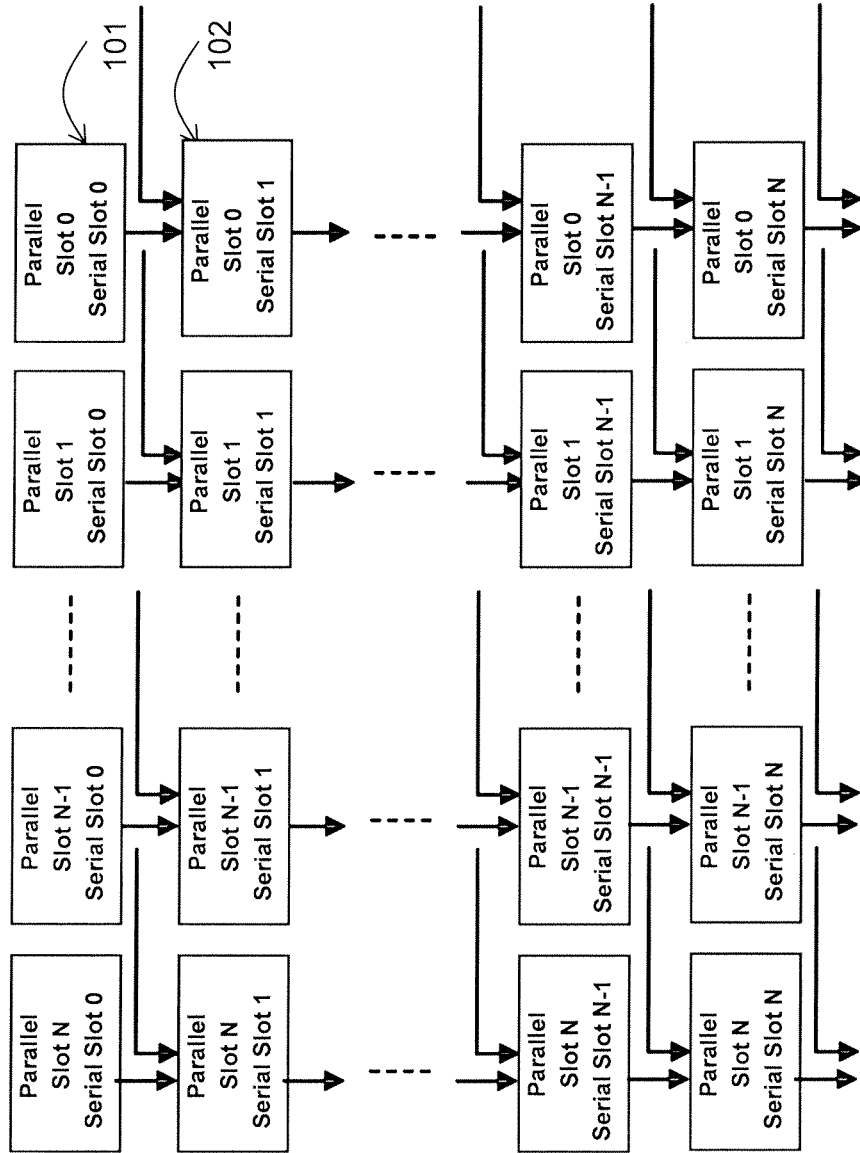

FIG. 1

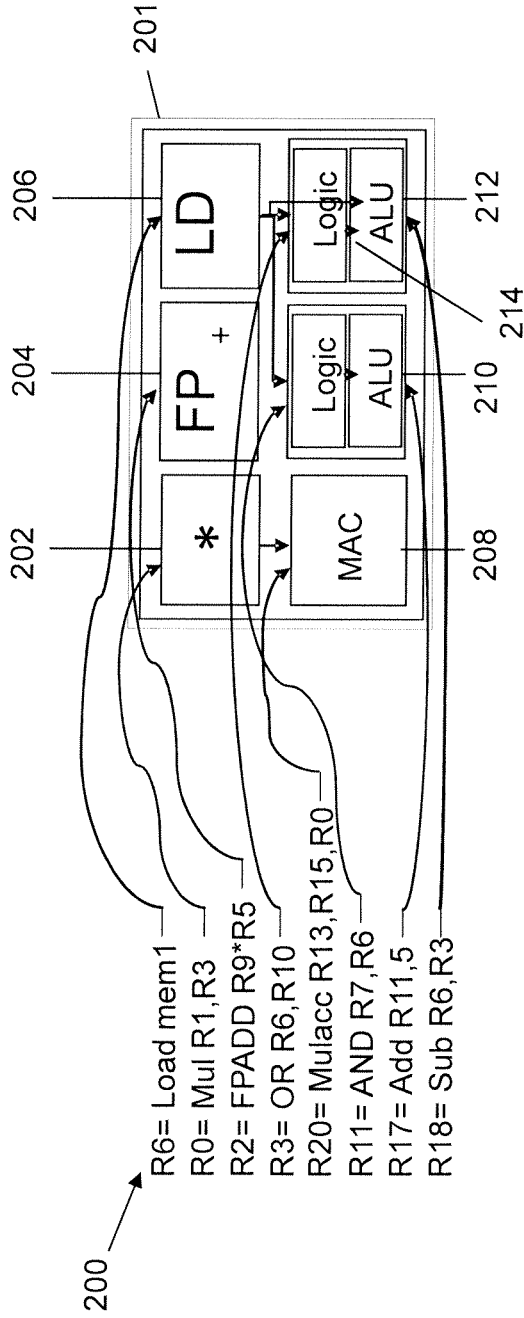

FIG. 2A

Dest1/S1	Dest2/S2	S3	S4	Dest1/S1	Dest2/S2	S3	S4	Dest1/S1	Dest2/S2	S3	S4
Dest1/S1	Dest2/S2	S3	S4	Dest1/S1	Dest2/S2	S3	S4	Dest1/S1	Dest2/S2	S3	S4
Complex operation Opcode : MUL				Complex operation Opcode : FP+				Complex operation Opcode : LD			
Complex operation Opcode : MAC				Simple opcode1 : Logic				Simple opcode2 : ALU			

FIG. 2B

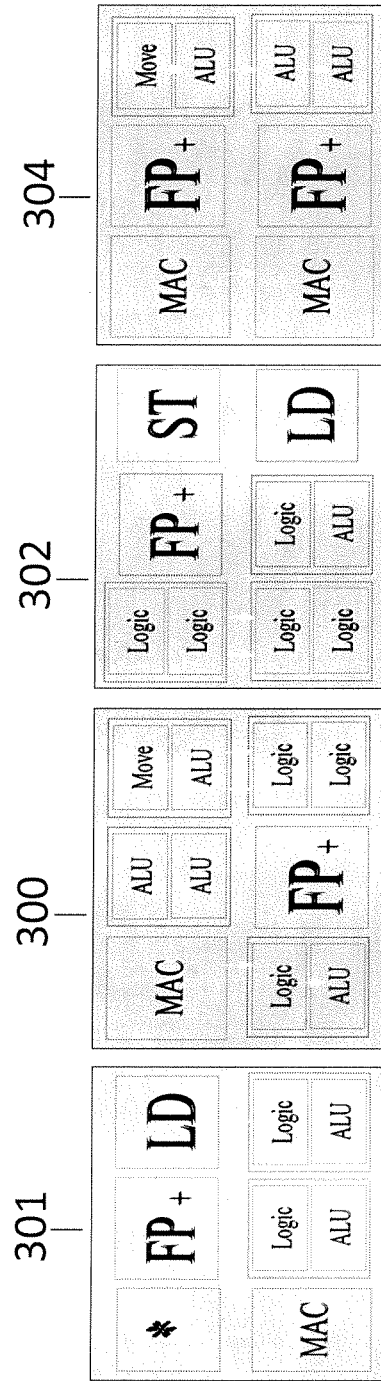

FIG. 3





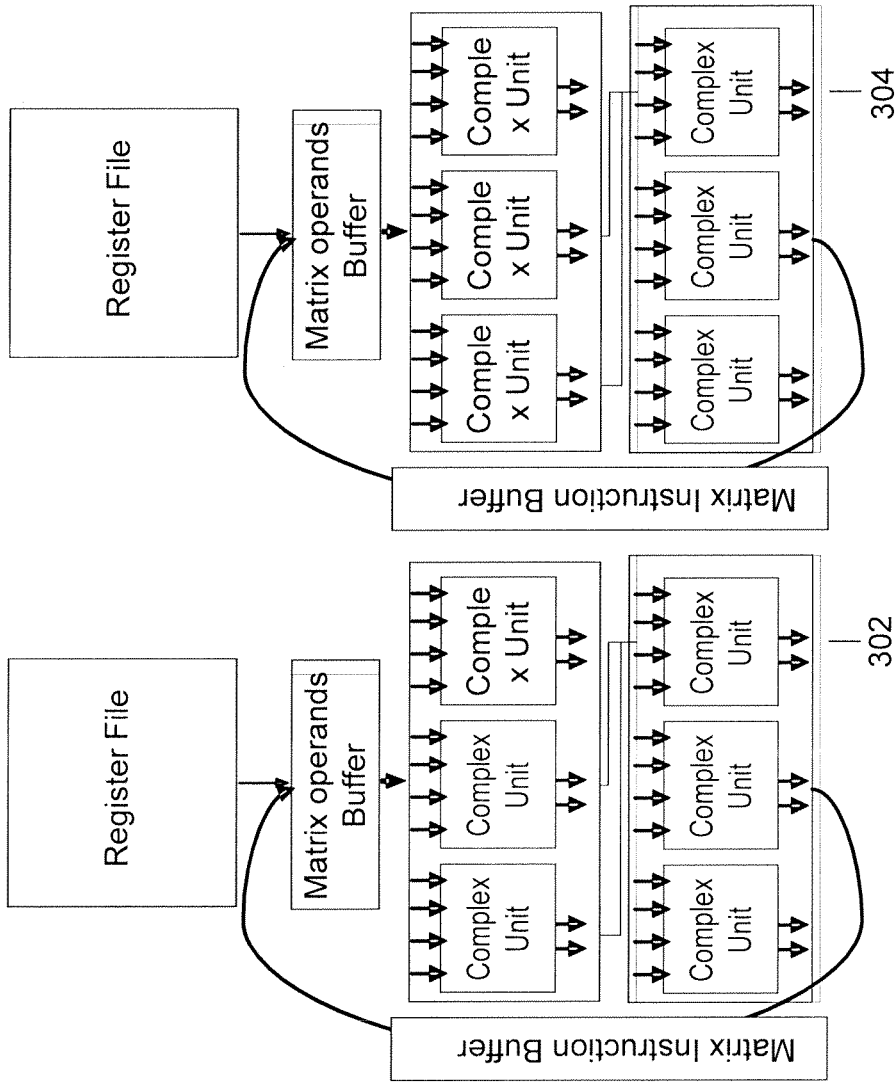

FIG. 4A (cont'd)

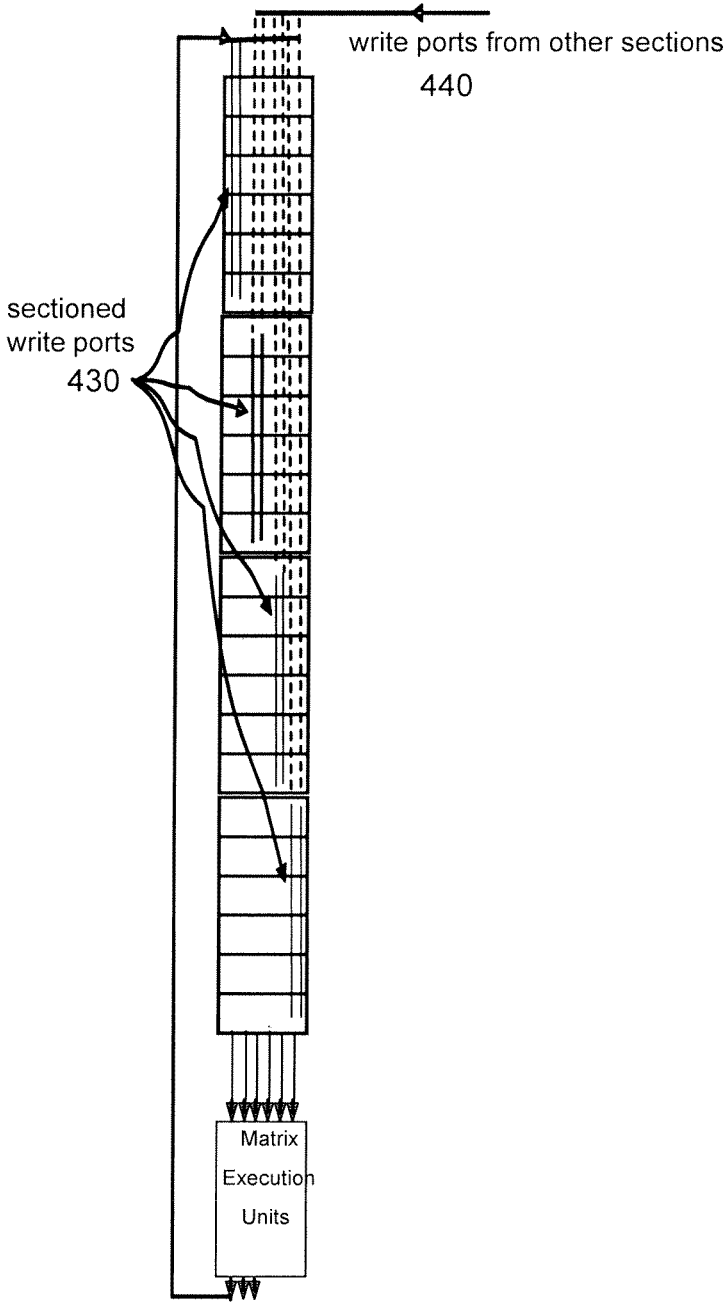

FIG. 4B

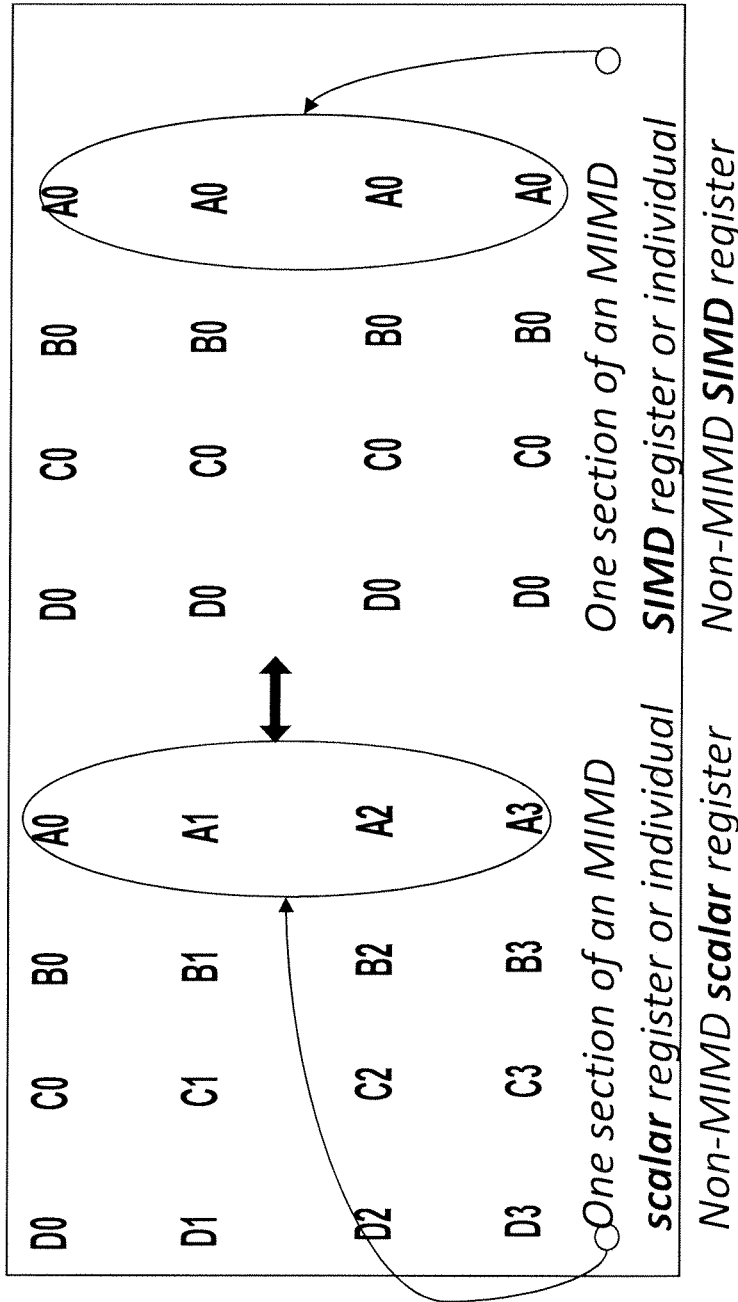

FIG. 5

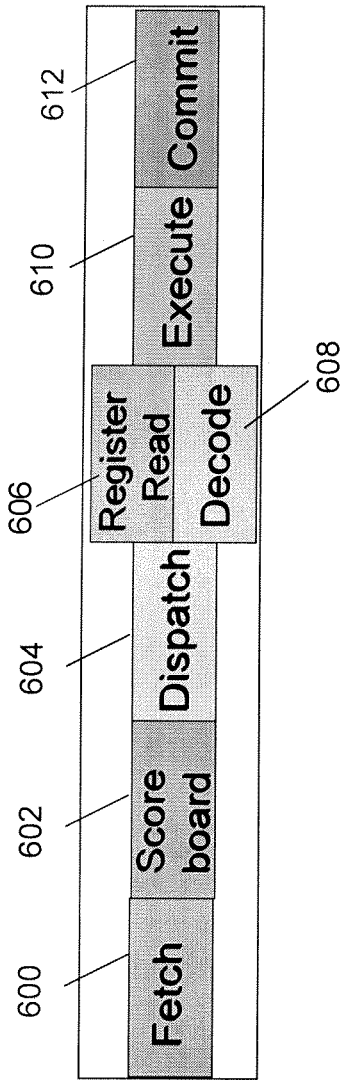

FIG. 6

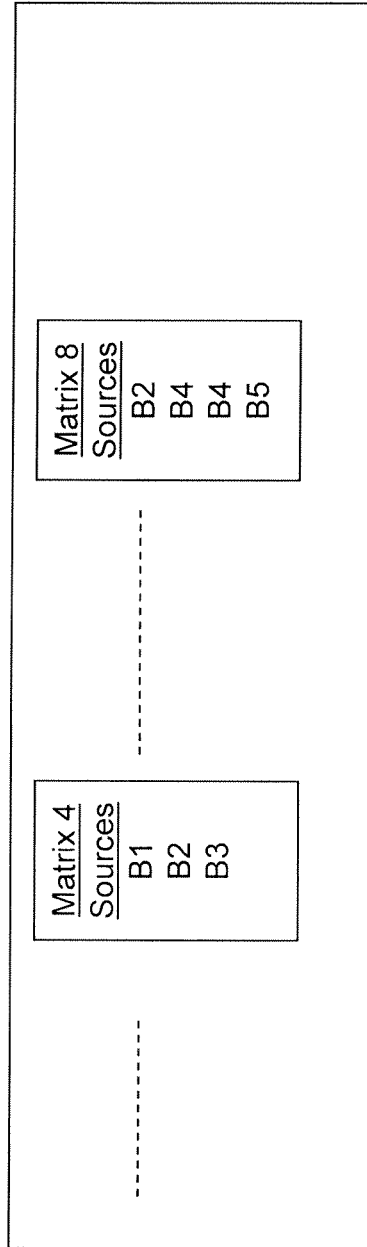

FIG. 7

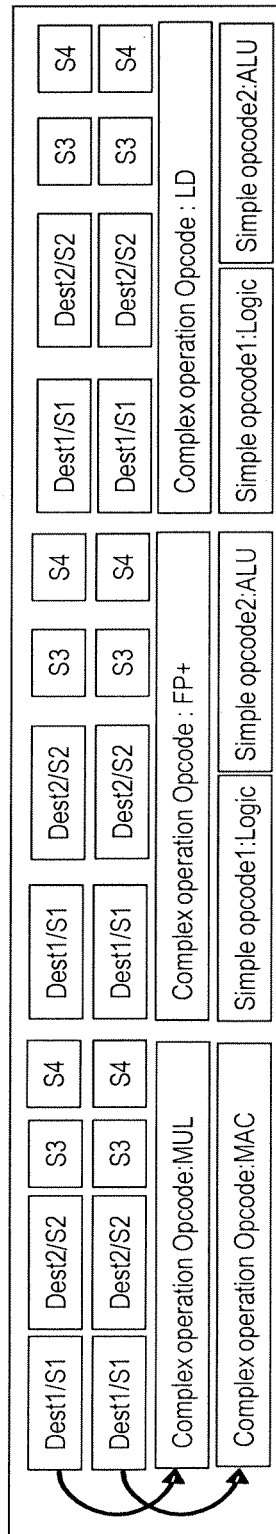

FIG. 8

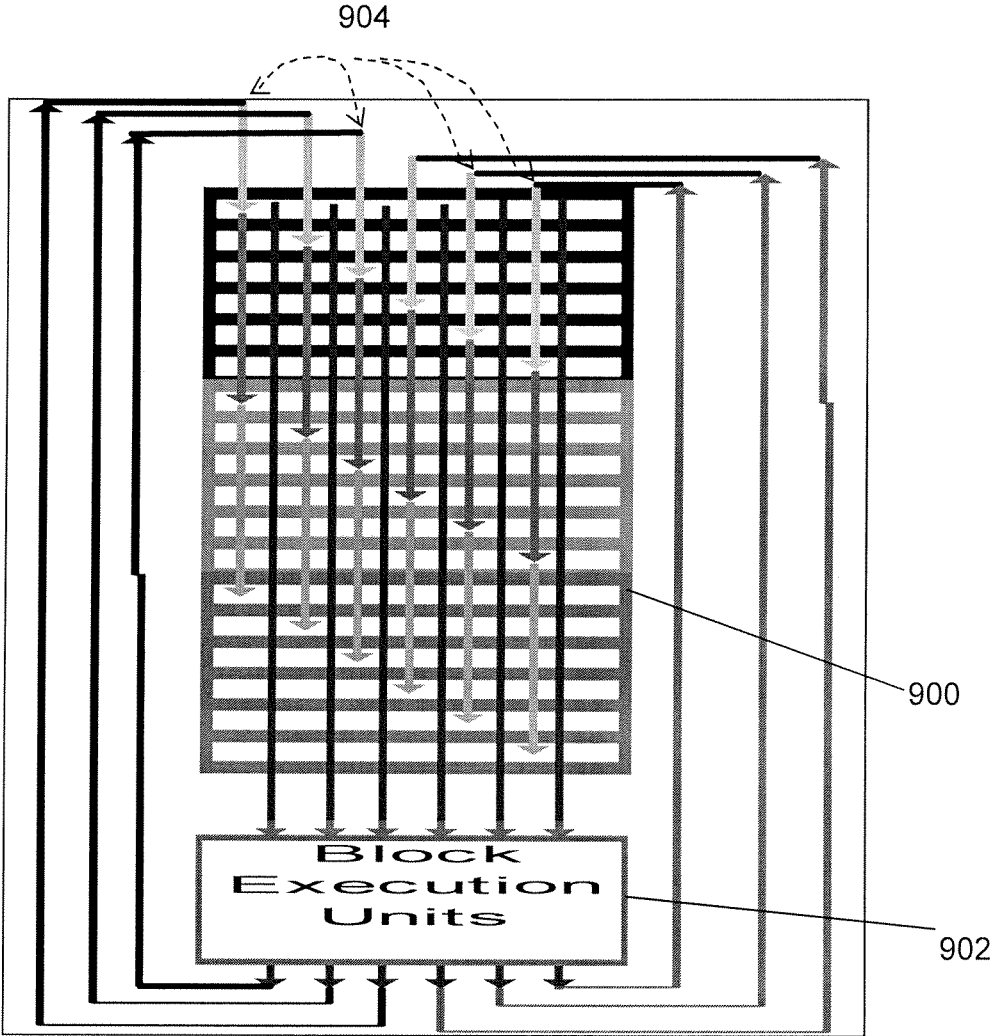

FIG. 9

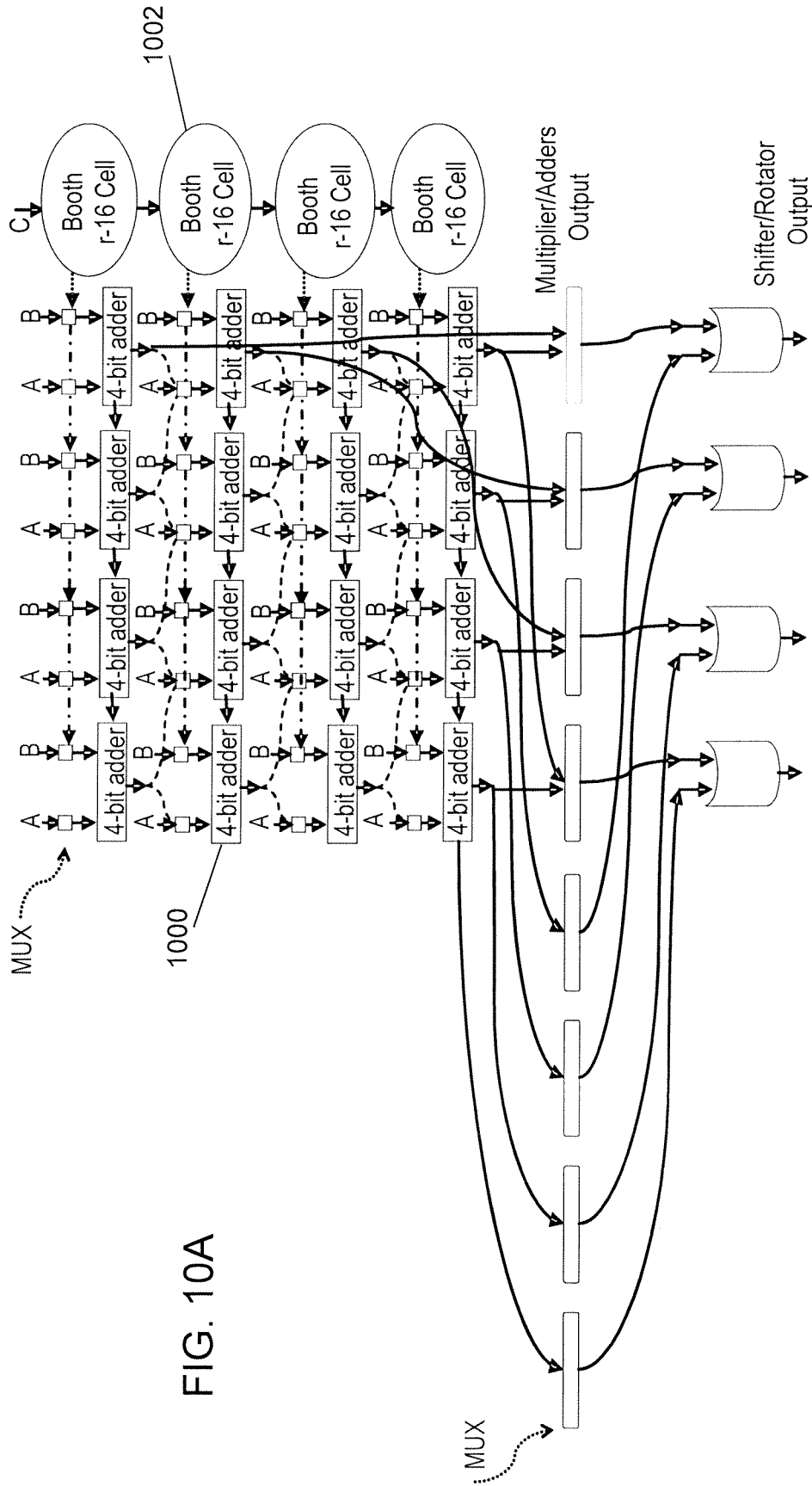

FIG. 10A

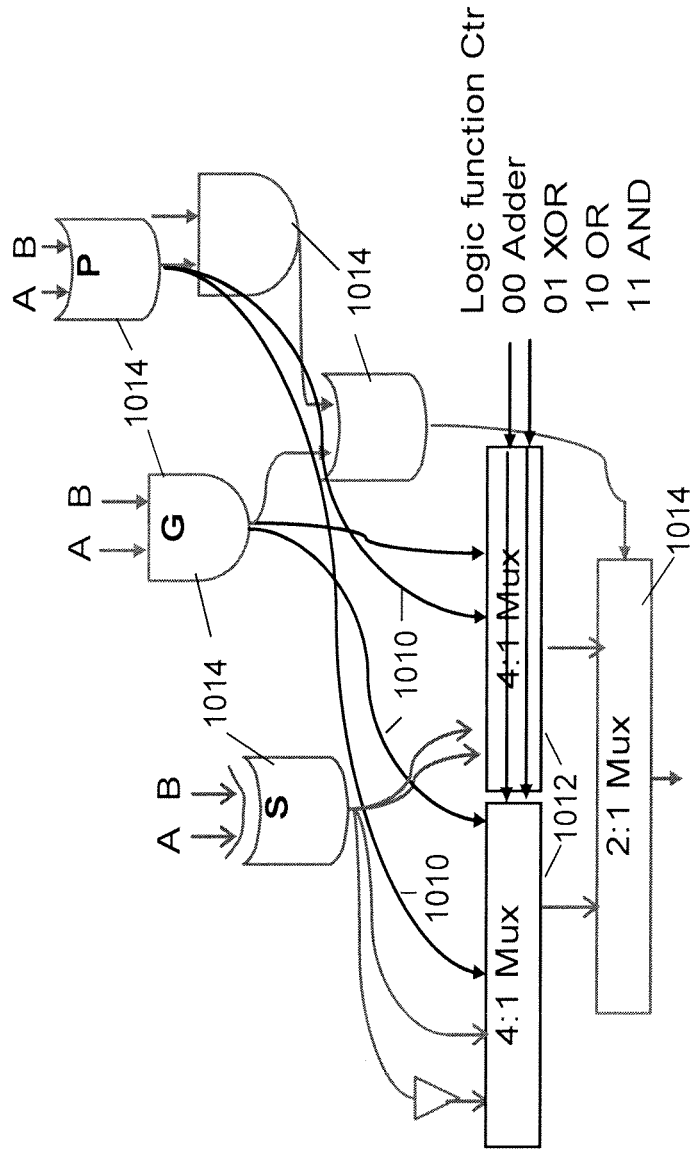

FIG. 10B



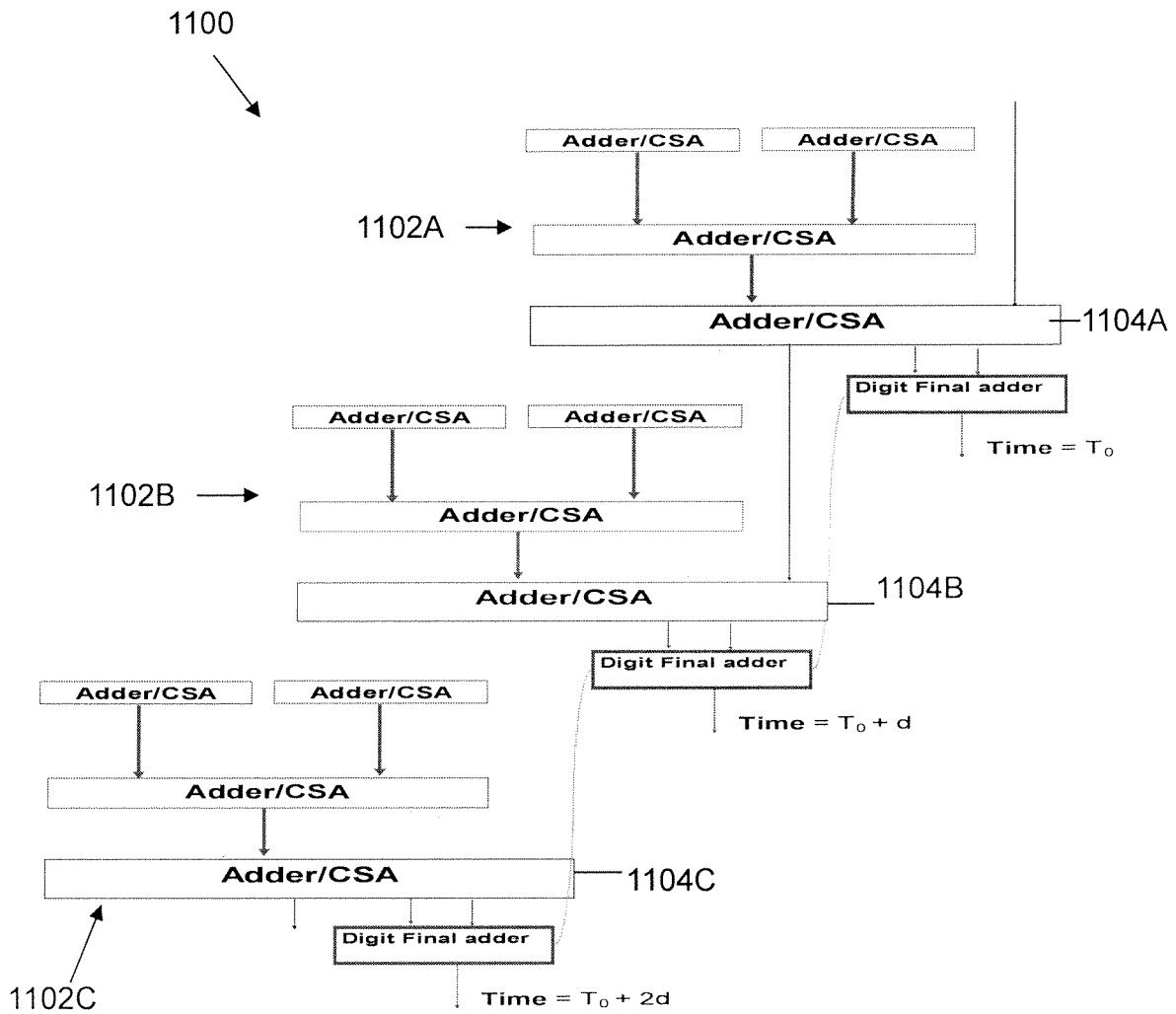

Figure 11

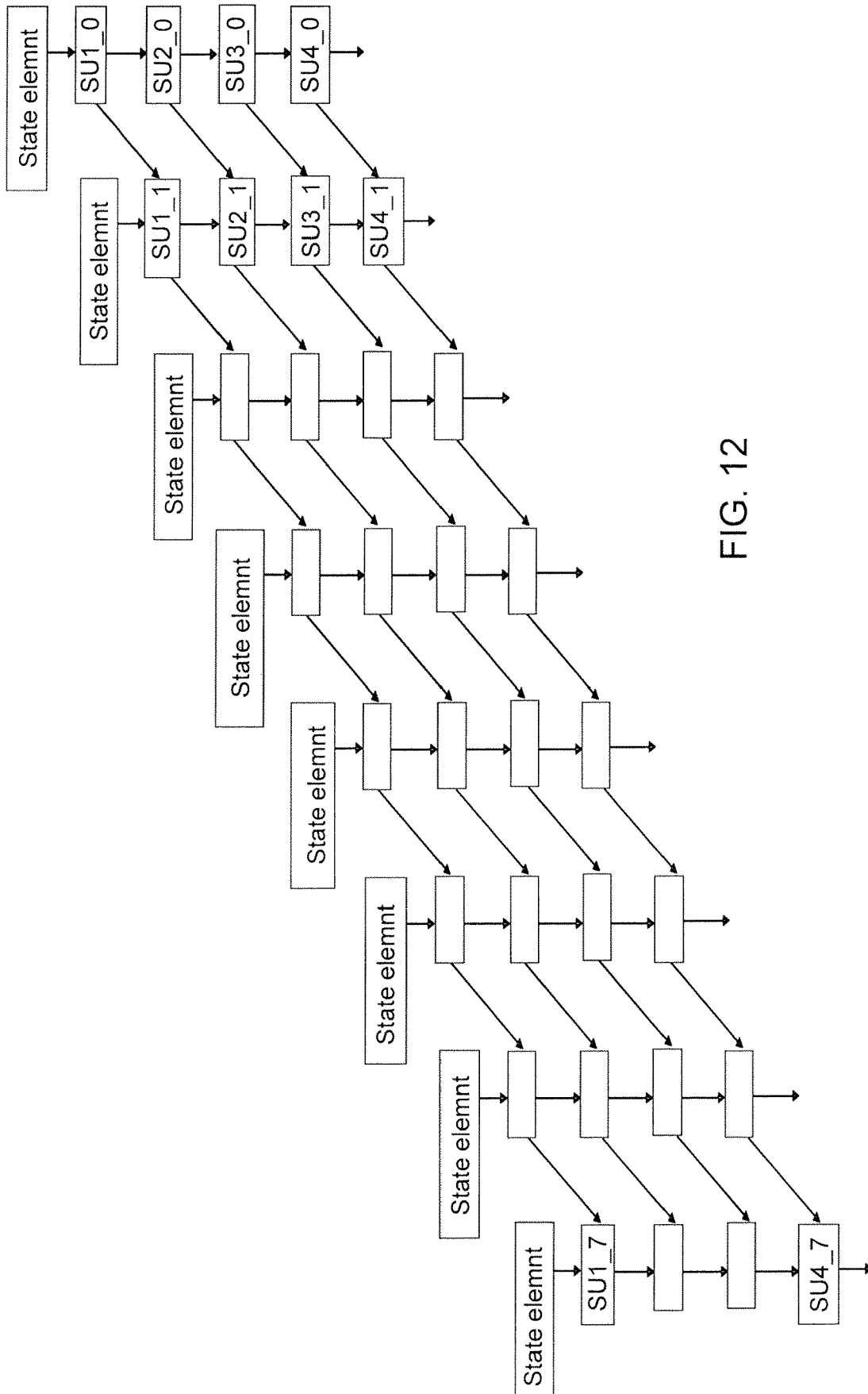
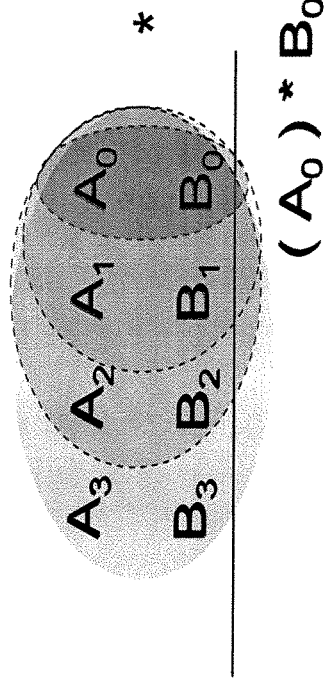

FIG. 12

$$\begin{array}{c}
 \text{A}_3 \text{ A}_2 \text{ A}_1 \text{ A}_0 \\
 \text{B}_3 \text{ B}_2 \text{ B}_1 \text{ B}_0 \\
 \hline
 \text{B}_3 \text{ B}_2 \text{ B}_1 \text{ B}_0 \text{ B}_0 \\
 \text{A}_3 \text{ A}_2 \text{ A}_1 \text{ A}_0 \text{ B}_0 \\
 \text{A}_3 \text{ A}_2 \text{ A}_1 \text{ A}_0 \text{ B}_1 \\
 \text{A}_3 \text{ A}_2 \text{ A}_1 \text{ A}_0 \text{ B}_2 \\
 \text{A}_3 \text{ A}_2 \text{ A}_1 \text{ A}_0 \text{ B}_3 \\
 \hline
 \end{array}$$

FIG. 13  
(Prior Art)



$$\begin{aligned}
 & (A_0) * B_0 \\
 & + \\
 & (B_0) * A_1 + (A_1 A_0) * B_1 \\
 & + \\
 & (B_1 B_0) * A_2 + (A_2 A_1 A_0) * B_2 \\
 & + \\
 & (B_2 B_1 B_0) * A_3 + (A_3 A_2 A_1 A_0) * B_3
 \end{aligned}$$

FIG. 14

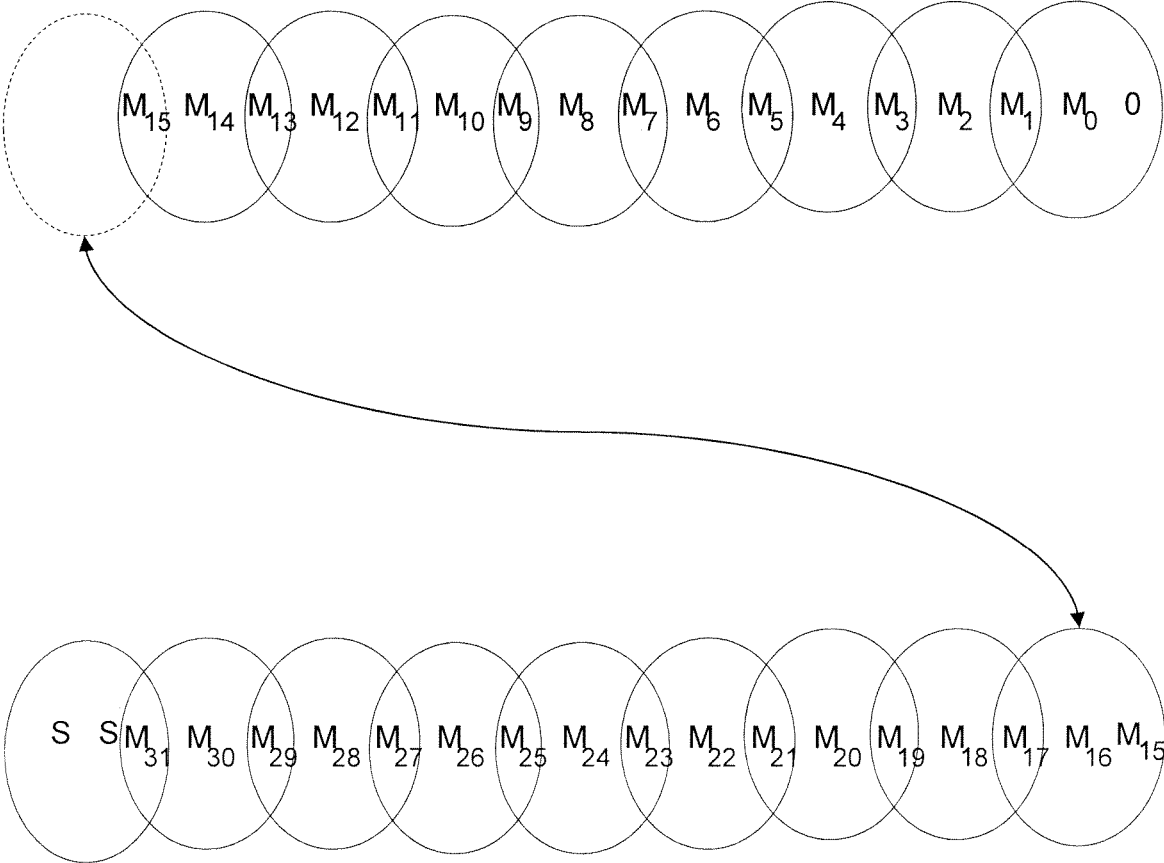

FIG. 15  
(Prior Art)

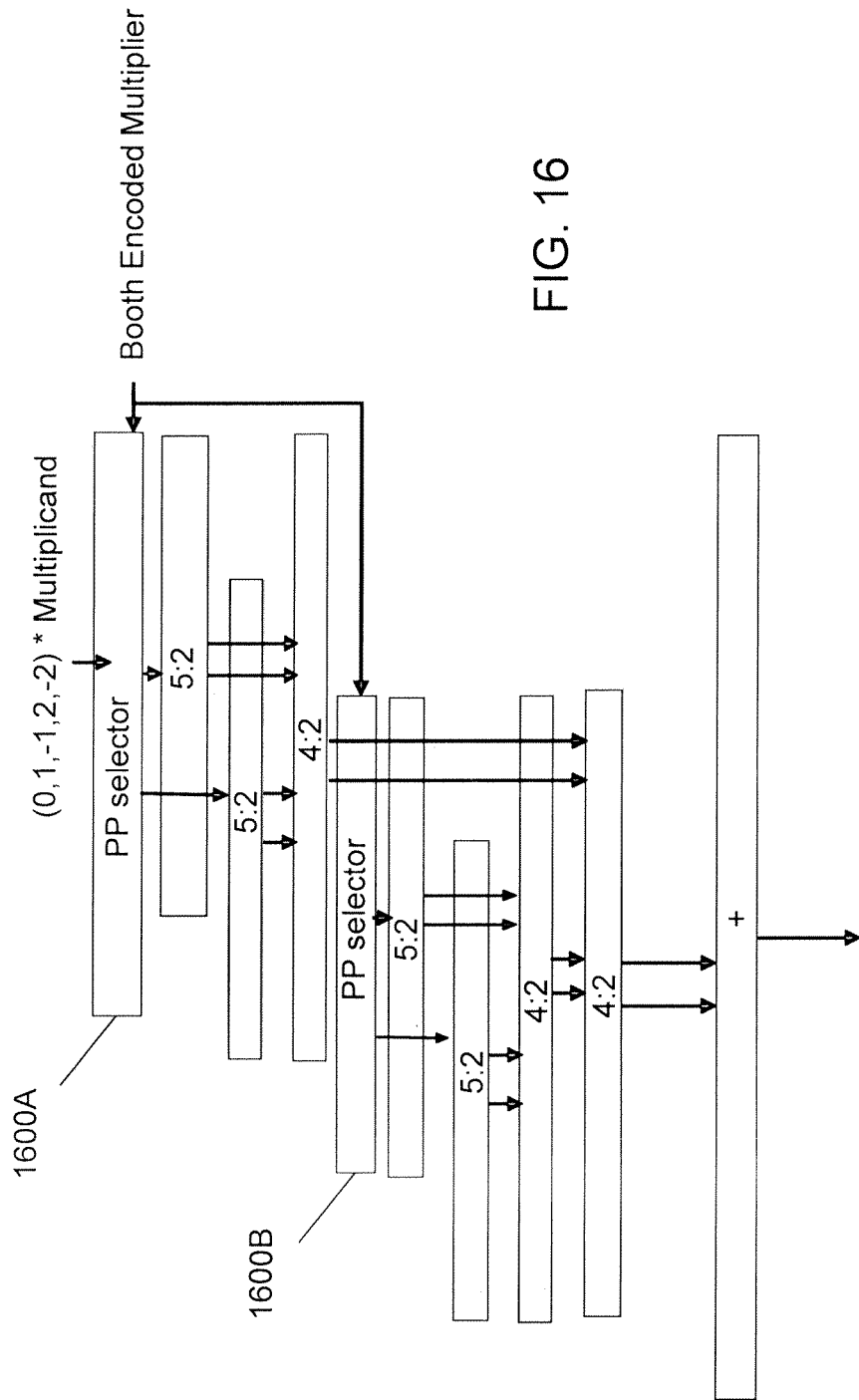

FIG. 16

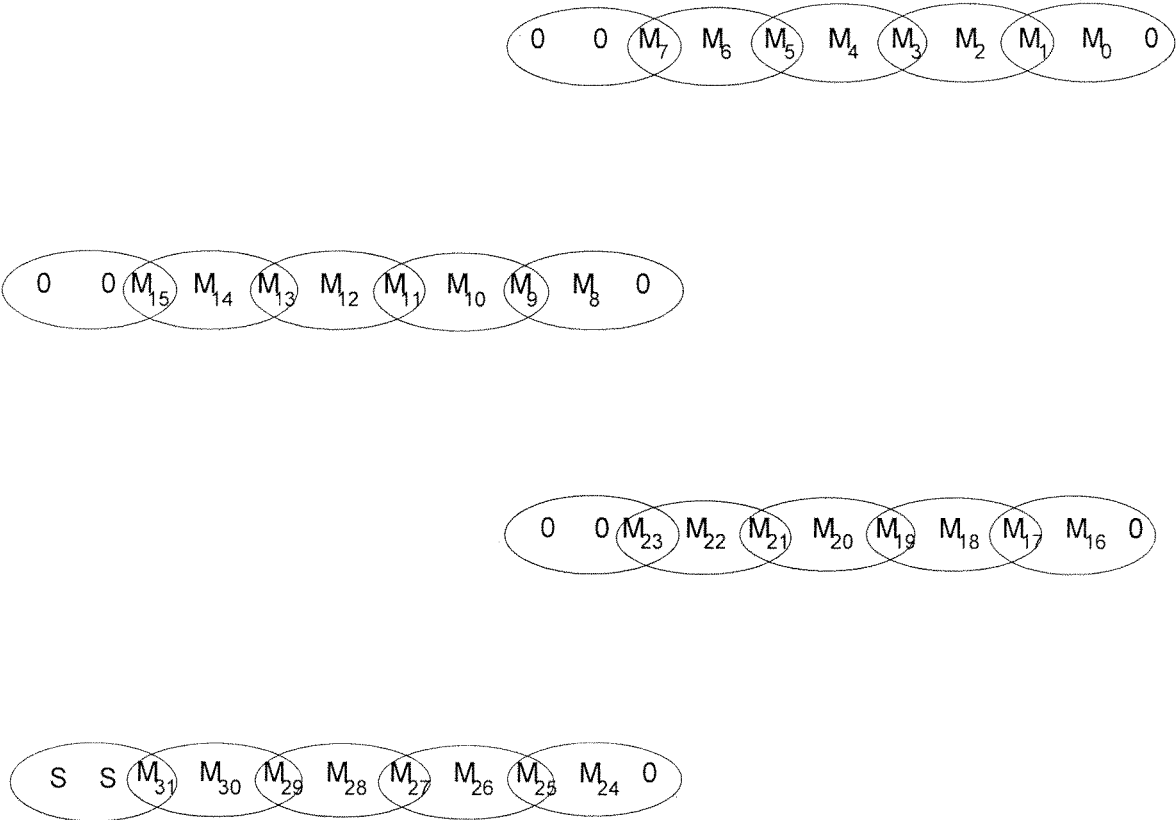

FIG. 17

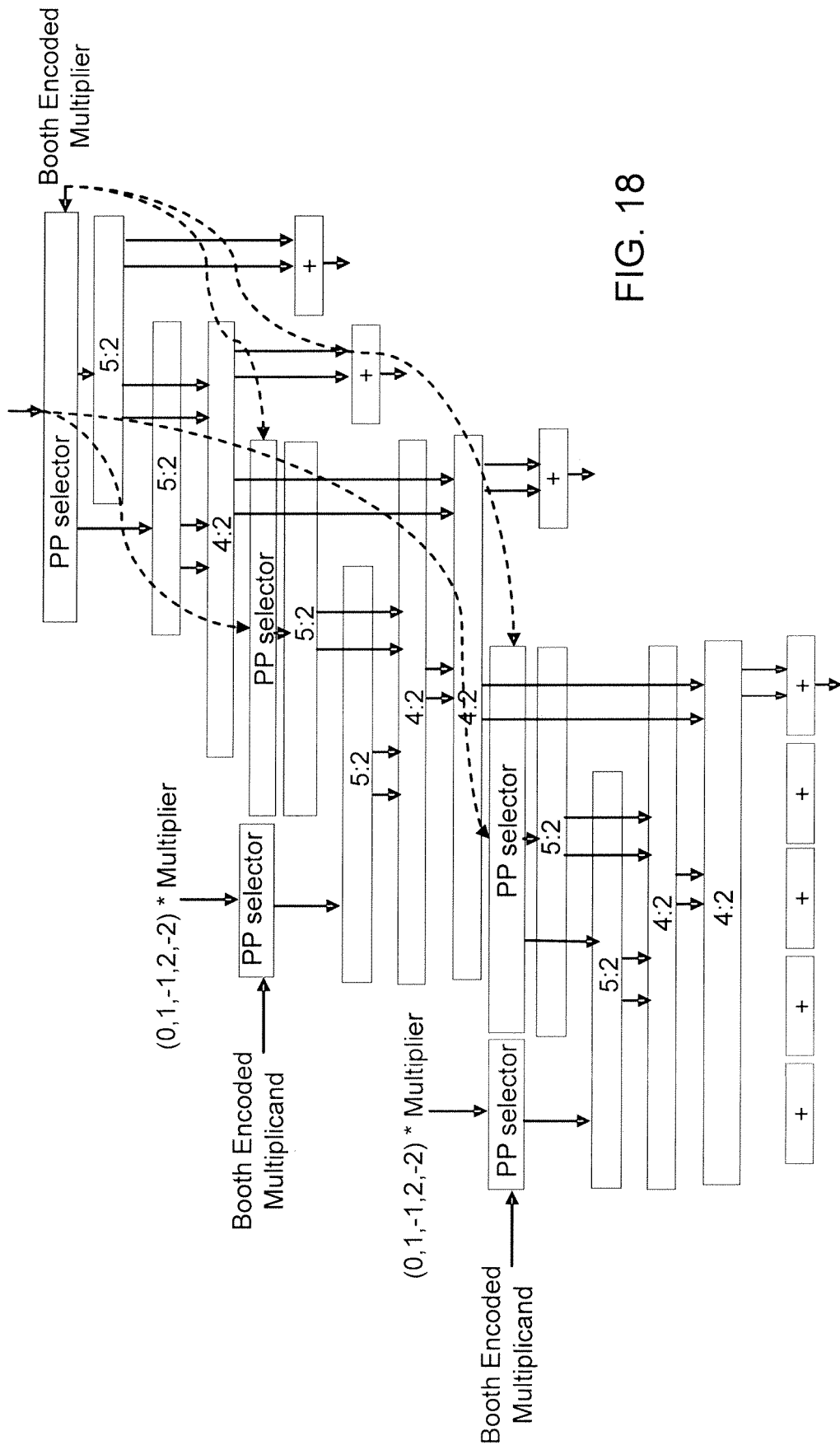

FIG. 18



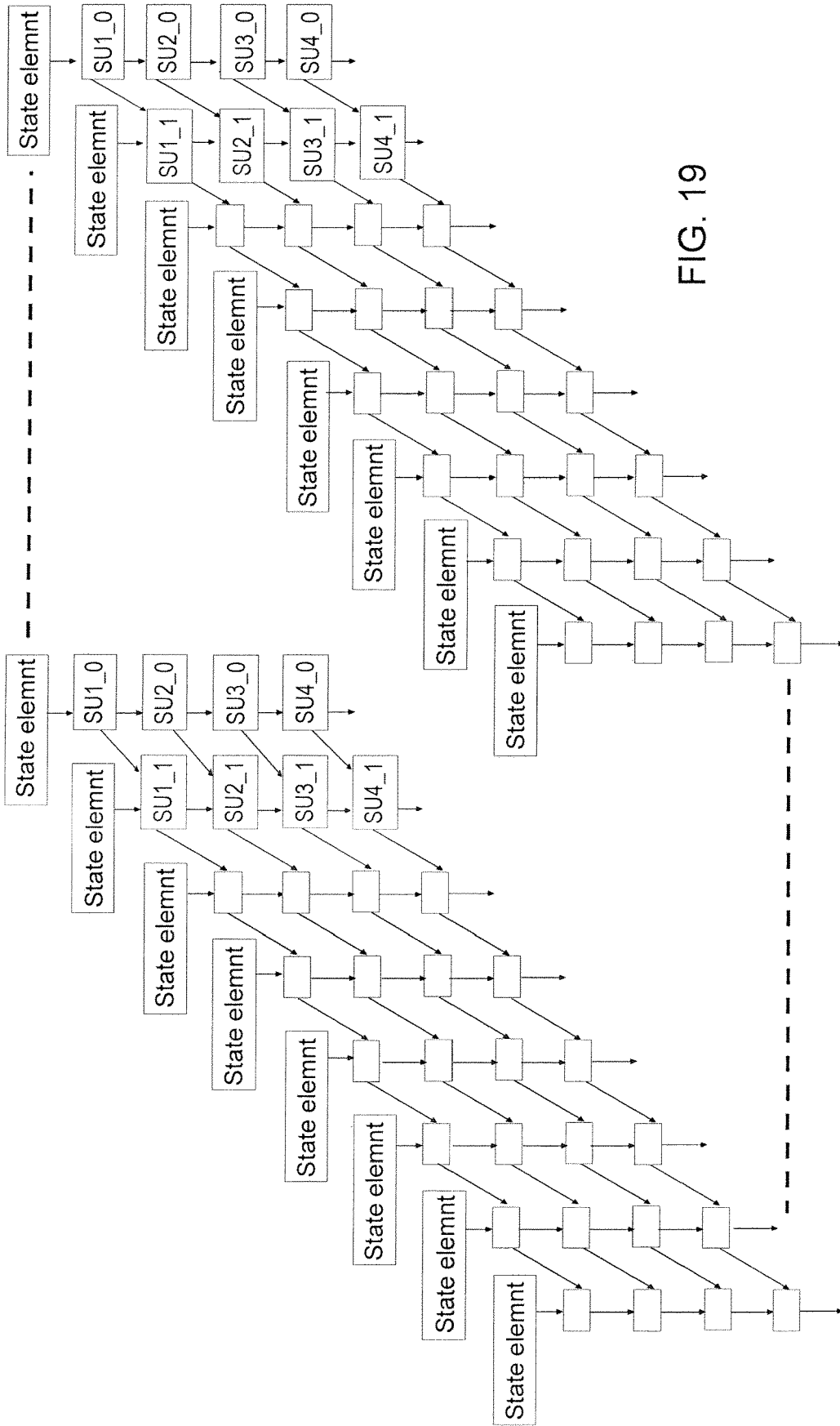

FIG. 19

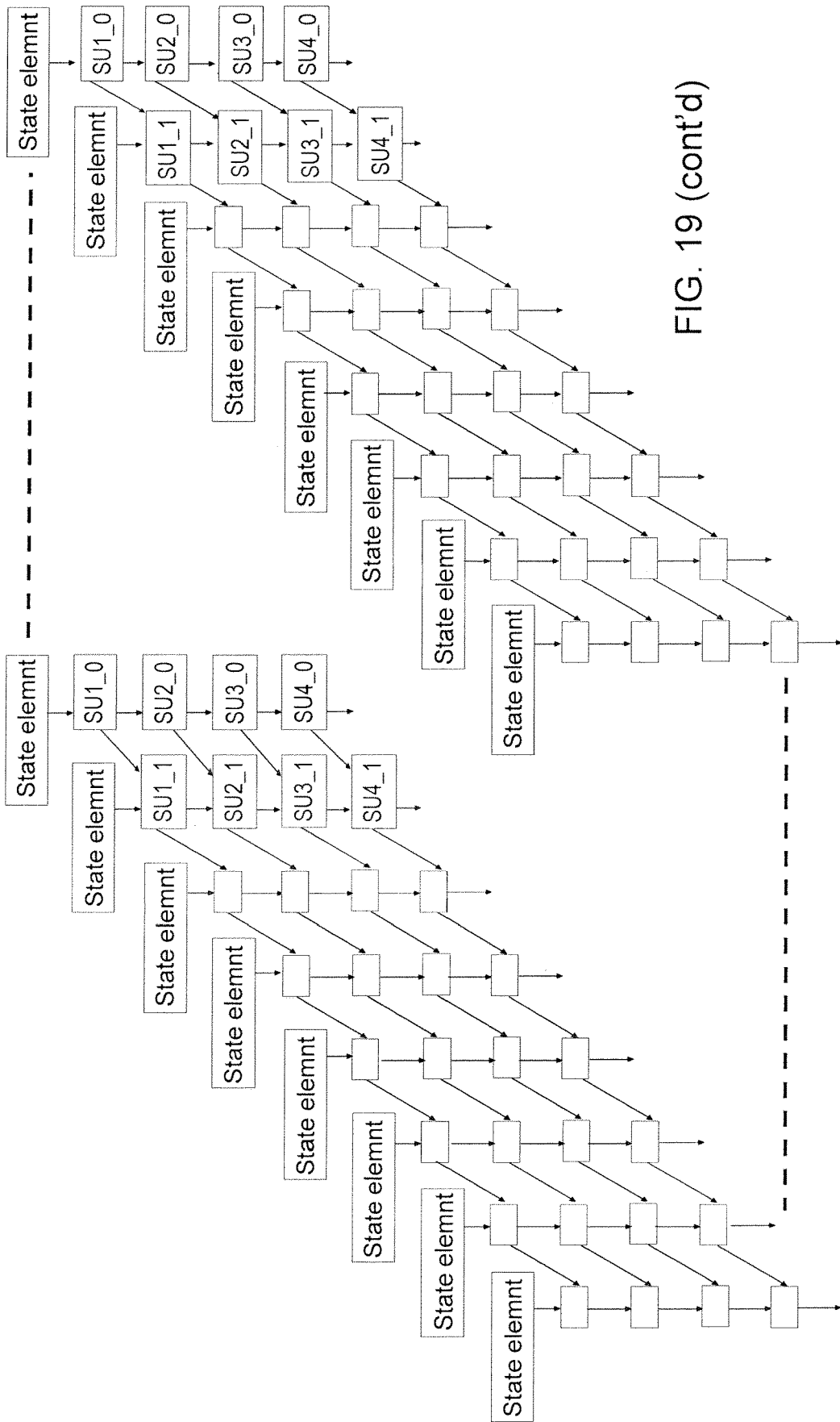

FIG. 19 (cont'd)

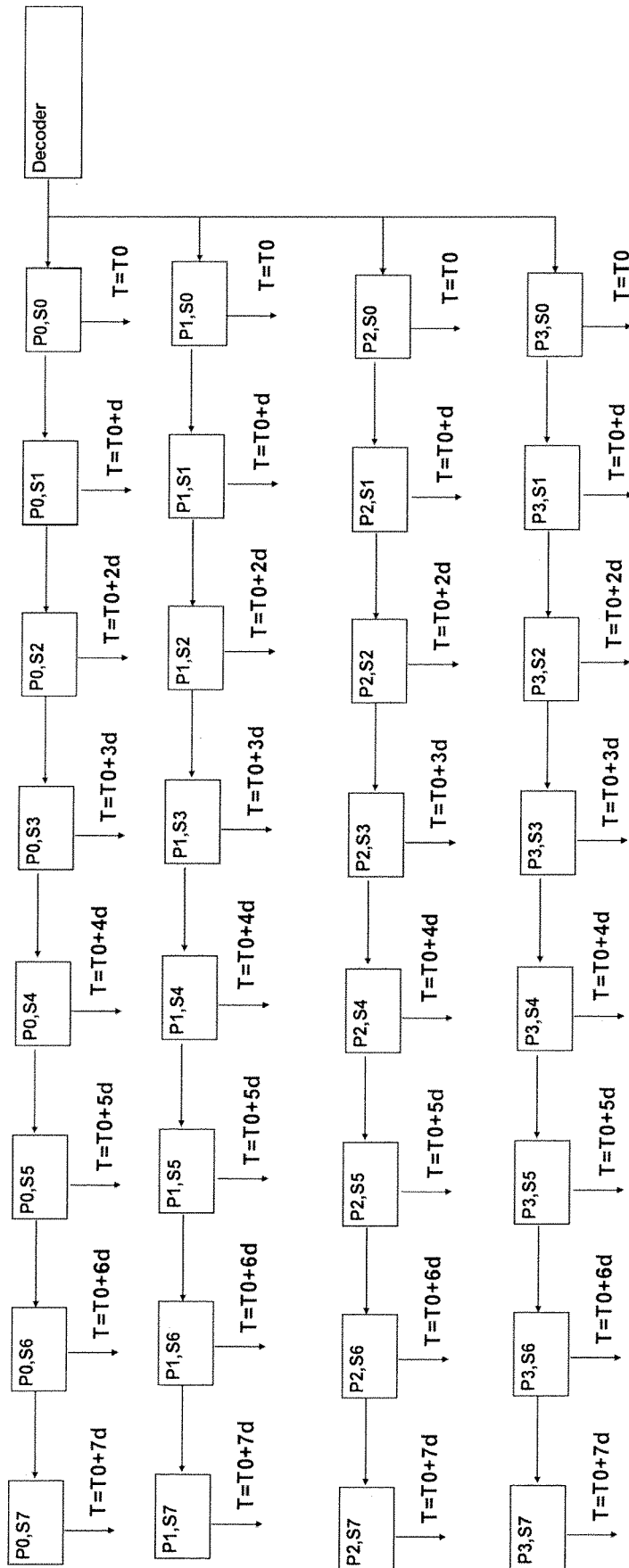

FIG. 20

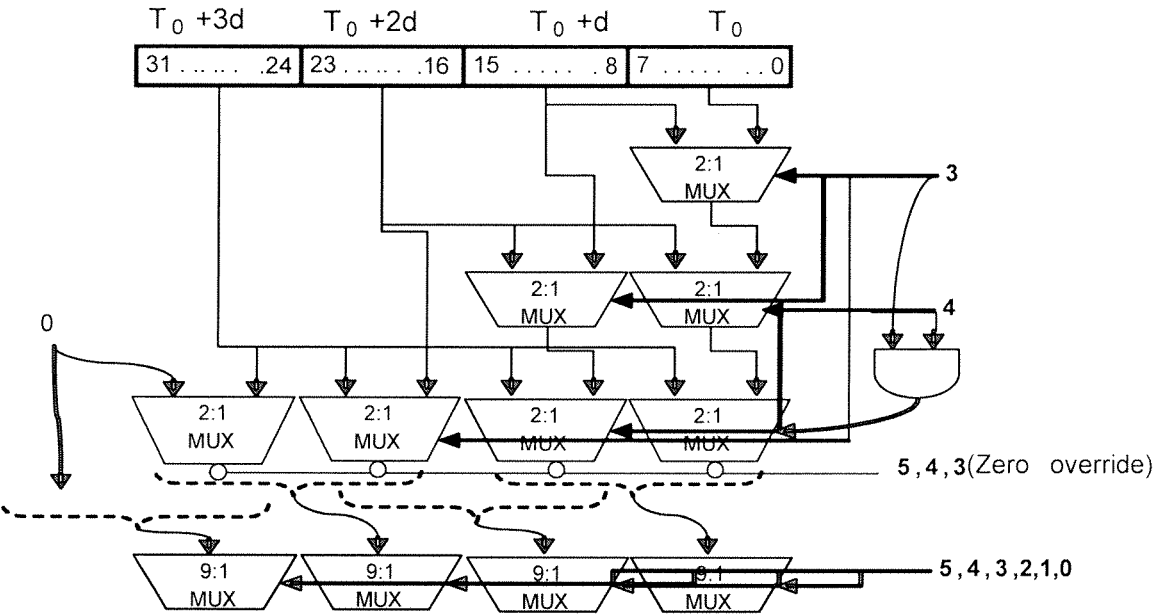

FIG. 21

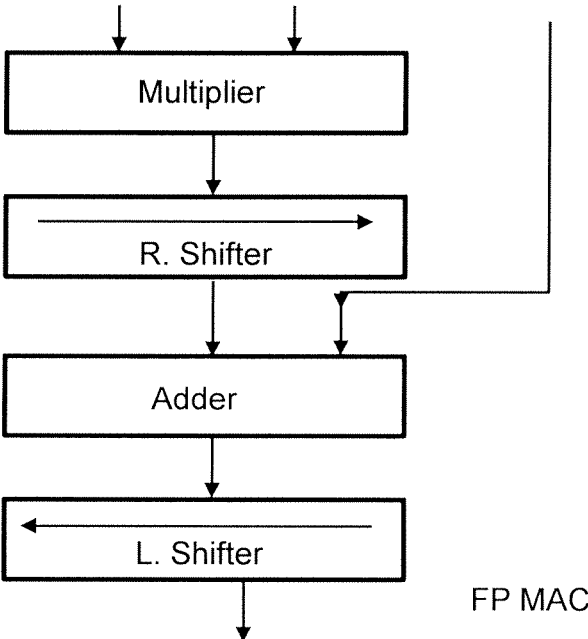

FIG. 22

**APPARATUS AND METHOD FOR  
PROCESSING AN INSTRUCTION MATRIX  
SPECIFYING PARALLEL AND DEPENDENT  
OPERATIONS**

CROSS REFERENCE TO RELATED  
APPLICATIONS

This application is a continuation of U.S. application Ser. No. 15/853,323 filed Dec. 22, 2017 (now U.S. Pat. No. 10,289,605 issued May 14, 2019), which is a continuation of U.S. application Ser. No. 14/733,827 filed Jun. 8, 2015 (now U.S. Pat. No. 9,886,416 issued Feb. 6, 2018), which is a continuation of U.S. application Ser. No. 13/691,609 filed Nov. 30, 2012 (now U.S. Pat. No. 9,053,292 issued Jun. 9, 2015), which is a continuation of U.S. application Ser. No. 12/296,919 entered Dec. 19, 2008 (now U.S. Pat. No. 8,327,115 issued Dec. 4, 2012), which is the National Stage of International Application No. PCT/US2007/066536 filed Apr. 12, 2007, which claims priority to U.S. Provisional Application No. 60/792,219 filed Apr. 14, 2006 and U.S. Provisional Application Nos. 60/791,782 and 60/791,649 filed Apr. 12, 2006, which are hereby incorporated by reference.

BACKGROUND

The invention relates generally to computer architectures. More particularly, the invention relates to a computer architecture to process matrix instructions specifying parallel and dependent operations.

Improving computer architecture performance is a difficult task. Improvements have been sought through frequency scaling, Single Instruction Multiple Data (SIMD), Very Long Instruction Word (VLIW), multi-threading and multiple processor techniques. These approaches mainly target improvements in the throughput of program execution. Many of the techniques require software to explicitly unveil parallelism. In contrast, frequency scaling improves both throughput and latency without requiring software explicit annotation of parallelism. Recently, frequency scaling hit a power wall so improvements through frequency scaling are difficult. Thus, it is difficult to increase throughput unless massive explicit software parallelization is expressed.

In view of the foregoing, it would be desirable to improve computer architecture performance without reliance upon frequency scaling and massive explicit software parallelization.

SUMMARY

A matrix of execution blocks form a set of rows and columns. The rows support parallel execution of instructions and the columns support execution of dependent instructions. The matrix of execution blocks process a single matrix of instructions specifying parallel and dependent instructions.

BRIEF DESCRIPTION OF THE DRAWINGS

The invention is more fully appreciated in connection with the following detailed description taken in conjunction with the accompanying drawings, in which:

FIG. 1 illustrates an architecture to support the execution of parallel and dependent instructions in accordance with an embodiment of the invention.

FIG. 2A illustrates the mapping of serial instructions to produce parallel and dependent operations in an execution matrix of the invention.

FIG. 2B illustrates the mapping of operations to an execution matrix of the invention.

FIG. 3 illustrates a row of execution blocks that may be utilized in accordance with an embodiment of the invention.

FIG. 4A illustrates execution blocks and supporting register files and buffers that may be utilized in accordance with an embodiment of the invention.

FIG. 4B illustrates a register file configured in accordance with an embodiment of the invention.

FIG. 5 illustrates various data configurations that may be utilized with a buffer of the invention.

FIG. 6 illustrates a pipeline that may be utilized in accordance with an embodiment of the invention.

FIG. 7 illustrates matrix instruction processing in accordance with an embodiment of the invention.

FIG. 8 illustrates the mapping of operations to an execution block of the invention.

FIG. 9 illustrates a matrix buffer utilized in accordance with an embodiment of the invention.

FIG. 10A illustrates a universal unit to implement operations of the invention.

FIG. 10B illustrates a one bit cell of a carry look-ahead adder used in the 4-bit adder in FIG. 10A.

FIG. 11 illustrates a Time-Lag Sliced Architecture (TLSA) unit configured in accordance with an embodiment of the invention.

FIG. 12 illustrates multiple TLSA units in a staggered configuration in accordance with an embodiment of the invention.

FIG. 13 illustrates a prior art multiplication technique.

FIG. 14 illustrates a time-lag multiplication technique utilized in accordance with an embodiment of the invention.

FIG. 15 illustrates prior art Booth encoded multiplication.

FIG. 16 illustrates logic to implement the Booth encoded multiplication of FIG. 15.

FIG. 17 illustrates Booth encoded multiplication in accordance with an embodiment of the invention.

FIG. 18 illustrates logic to implement the Booth encoded multiplication of FIG. 17.

FIG. 19 illustrates a memory/register file data block configured in accordance with an embodiment of the invention.

FIG. 20 illustrates a time slice memory configured in accordance with an embodiment of the invention.

FIG. 21 illustrates a TLSA architecture with a permute/shift unit configured in accordance with an embodiment of the invention.

FIG. 22 illustrates a floating point multiply accumulate unit configured in accordance with an embodiment of the invention.

Like reference numerals refer to corresponding parts throughout the several views of the drawings.

DETAILED DESCRIPTION OF THE  
INVENTION

It is highly beneficial to allow software that is not explicitly parallelized to execute on single processor hardware that is capable of processing massive numbers of instructions in a short latency pipeline. To give a current perspective on current solutions; super scalar processors can practically process 4-5 instructions in a cycle at peak instants, which is similar to what a good VLIW compiler can achieve at peak instants. It is well recognized that scaling super scalar

processors to schedule 10's of instructions in a single cycle/instant is not practically achievable. Similarly, compilers that try to parallelize general programs for VLIW architectures with 10's of slots end up leaving a lot of those slots unfilled.

The invention provides architecture and processor implementations enabling massive parallelism allowing large number of instructions is to be fetched, scheduled, decoded, and executed in a short pipeline, achieving an impressive improvement in the throughput of execution, while maintaining a much optimized latency of operations in single processor pipeline with efficient timing, power, area and routing.

In this new architecture, named Ultra Large Instruction Matrix (ULIM), fixed size instruction matrix templates are scheduled to be executed in the hardware as a matrix of parallel and dependent groups of instructions. In contrast to VLIW where only parallel instructions are scheduled using the Very Long Instruction width template, the template of the ULIM architecture encapsulates a group of instructions that have both parallel and dependent instructions. This can be viewed as a 2 dimensional template matrix where parallel instructions are allocated horizontally while dependent instructions are allocated only vertically. This template is sent as one instruction matrix to the execution hardware, where each execution block processes an instruction matrix.

FIG. 1 illustrates such a template where if an instruction is put in slot **101** then another instruction that can execute in parallel to it can be put in any of the parallel slots 1 to N in that same row. However, an instruction that depends on the one placed at slot **101** cannot be placed in the same row and has to be placed on a following row (e.g., parallel slot 0 of serial slot 1) **102**. The slot noted by **102** can receive as an input either the result produced by **101** or an external input operand or a combination of both. The execution model of such an instruction template is that instructions at any row will execute before those in the next row.

The ULIM instructions' grouping can be scheduled statically by a ULIM compiler or dynamically by a ULIM hardware composition unit. The significance of this architecture is clear if it is compared to a traditional architecture. In a traditional architecture, one row of N.sub.1 parallel instructions can be put in a template, such as VLIW or SIMD template. This means each cycle, N.sub.1 instructions can be executed (all have to be insured to be parallel which is a serious constraint for a large N). On the other hand, the ULIM architecture can execute N.sub.1\*N.sub.2 instructions each cycle by pipelining execution at each row boundary. In spite of executing N.sub.1\*N.sub.2 instructions each cycle, the ULIM architecture imposes only the same constraint of insuring that N.sub.1 instructions execute in parallel.

The instruction matrix template can be constructed by the programmer or by a compiler/hardware formatter where neither of them need to be constrained by finding only parallel instructions to schedule every cycle. Available parallel instructions can be picked and placed horizontally in rows. The parallel instructions can be augmented by dependent instructions that are placed in subsequent rows. A matrix can execute in a single or multiple cycles. A matrix can localize storage of operands near the execution hardware to optimize interconnect complexity, area, speed and power.

The invention is more fully appreciated in connection with the example of FIG. 2A. FIG. 2A illustrates an example of an instruction sequence **200** presented by a single serial program flow. The figure also shows how the instructions are grouped to form a single instruction matrix with both serial

and parallel slots utilized in the matrix template. The matrix template is applied to an execution block **201**. The execution block **201** includes a multiplication unit **202**, a floating point add unit **204**, a load unit **206**, a multiple accumulate (MAC) unit **208**, a logic unit (e.g., an ALU) **210**, and another logic unit **212**.

Thus, an instruction matrix refers to an instruction group template with parallel and serial instructions. An execution block refers to a group of execution units that execute an instruction matrix. Execution units are individual computation units (e.g., both complex and simple units) within an execution block.

Straight arrows, such as **214**, indicate a dependency between instructions. The mapping can be done by the compiler, by the front end hardware or by a run time environment. FIG. 2A also depicts a formatted operation map showing the relative physical location of the instructions in the matrix as they will be executed on the corresponding hardware locations with parallel and serial dependency indicators.

As shown in FIG. 2A, the single stream program is reformulated into a matrix of instructions that statically determines serial execution, as well as instruction parallelism. For example, in the serial single program flow in FIG. 2A, the last instruction uses R3 as a source while the fourth instruction writes R3 as a result. This is mapped in the matrix template by placing the last instruction in a row that is subsequent to the row that the fourth instruction occupies. Line **214** illustrates this dependency.

The encoded instructions and their sources and destinations for the template shown in FIG. 2A are illustrated in FIG. 2b, where the instruction matrix template includes the opcode for the instructions and specifies the operands and result registers. Sources and destinations are separate from opcodes. This simplifies the decoding stage, the dependency resolution stage, and the register/memory read stage.

Several instruction matrices can be issued simultaneously, as shown in FIG. 3. FIG. 3 illustrates the instruction matrix operation map of **201**, represented here as **301**, along with alternately configured instruction matrices operation maps **300**, **302** and **304**. Simultaneous issuance may be implemented using one of the following models:

- 1—MIMD or SIMD: Software/compiler glues multiple matrices into a super matrix.
- 2—Threaded model: Each matrix belongs to a separate software or hardware thread.
- 3—Dynamic execution: Matrices from a single stream can be dynamically issued by the hardware if no dependency exists between them.

The instruction matrix templates represented by their operational maps in FIG. 3 are executed on a hardware that maps those instruction slots into execution units (inside the execution blocks) with a one to one correspondence. Granularity of the matrix allows forming a baseline matrix and combining those matrices to form a super matrix. This is illustrated in FIG. 4A, where 4 base-line instruction matrices execute in parallel on four execution blocks **301**, **300**, **302**, and **304**. Each execution block consists of 2 rows of complex units. The first row has 3 complex units (e.g., **402**, **404**, and **406**) and another row with 3 complex units (e.g., **408**, **410**, and **412**). Each complex unit can be operated to compute complex operations like a multiply, floating point add, or multiply-accumulate operations. Thus, for example, complex unit **402** may correspond to **202** of FIG. 2, complex unit **404** may correspond to **204** of FIG. 2, etc.

A complex unit can be operated to compute up to 4 simple operations, such as ALU operations. Such a complex unit is

thus shown to have multiple operands and multiple outputs. The units can be arranged to compute parallel operations or be sequenced to perform dependent operations. Each of the base-line instruction matrices can be run independent of other matrices in a threaded mode or a number of them can be combined in a group that can be run in the same cycle as a super instruction matrix composing a MIMD architecture. The whole matrix can be executed in one cycle or could be pipelined over multiple cycles.

As an example of operating the execution engine shown in FIG. 4A to execute the ULIM instruction template of FIG. 3, instruction MAC 208 is executed in complex unit 408, while the pair of simple Logical and ALU operations 210 are executed in a pair of units of 408. FIG. 4A illustrates the similarities and differences with a VLIW architecture. If in FIG. 4A we use the top 3 slots (402, 404, 406) to execute 3 parallel instructions, then these 3 slots in the ULIM template would resemble an equivalent VLIW instruction. Using the next row of simple units (408, 410, 412) to execute 3 more parallel instructions will mean that we are executing another equivalent of a VLIW that depends on the previous one. Thus, the ULIM architecture can be viewed as executing in space and with a fixed lag of time a fixed number of multiple VLIW instructions that are dependent on each other. In addition, the architecture allows executing a single complex instruction or multiple simple instructions in one single slot, which is not allowed in VLIW templates.

The 4 ULIM matrices indicated by operation maps 301, 300, 302, and 304 in FIG. 3 can be executed on the hardware in FIG. 4A. This may be implemented in one of 3 execution modes: either by being grouped together by the compiler/programmer to form a MIMD super instruction matrix, or each matrix can be executed independently in a threaded mode where separate threads execute simultaneously on each of the 4 hardware sections (301, 300, 302, and 304). The last execution mode possible is the ability to dynamically execute 4 different instruction matrices from a single thread using a hardware dependency check to insure no dependency exists between those different matrices that execute simultaneously on the 4 different hardware sections in FIG. 4A.

The register files 420 in FIG. 4A may be alternately configured depending upon the execution mode. In one mode, the register files are viewed as either a MIMD sectioned register file serving a MIMD width of 4 sections or they serve as 4 individual register files, each serving a separate thread. The register files can also support a dynamic execution mode where the 4 sections are one unified register file where data written to any register in a particular section is accessible by all units in the other sections. Switching between those modes can be seamless as different executing modes can alternate between individual thread baseline instruction matrix and MIMD super instruction matrix threads.

Each single instruction matrix is a mix of parallel and dependent instructions. Also, each individual instruction can be a scalar or SIMD instruction. At the finest granularity, the instruction can resemble variable data-width SIMD operating on multiple bytes/words or a single scalar entity.

In a multithread execution mode, each register file and its execution unit that executes a thread is totally independent of other register files and their threads. This is similar to each thread having its own register state. However, dependency between those threads can be specified. Each matrix that belongs to a thread will execute in the execution unit of that thread's register file. If only one thread or non-threaded single program is executed on the hardware in FIG. 4A, then

the following method is used to allow parallel matrices belonging to that single thread/program to be able to access the results written into the registers in the other sections. The way this is done is by allowing any matrix writing results into any one of the 4 register file sections to generate copies of those registers in the other register file sections. Physically this is done by extending the write ports of each section into the remaining sections. However, this is not scalable, as we cannot build an efficient register file with each memory cell having as many as 4 times the write ports as needed for one section alone. We present a mechanism where the register file is built such that it will not be impacted with such single thread register-broadcast extension. Such a mechanism is shown in FIG. 4B.

FIG. 4B shows one section of the register file consisting of 24 registers where a matrix that belongs to a single thread is storing the results of execution in that section's 24 entry register file. At the same time, 3 other parallel matrices are executing on the other 3 sections of FIG. 4A and the results of their execution are broadcasted to this register file section.

The way that the write ports are configured to enable single thread register broadcast is by limiting the results of each matrix to non-overlapping 6 register groups. This is implemented by having sectioned write ports where each write port writes into a separate group of registers 430. The write ports 440 coming from other sections will write into different non-overlapping groups of registers.

If this is a threaded mode or MIMD mode, then all the write ports that go to those non-overlapping groups are used by the results of this section to utilize and write to the full 24 entry register file and no broadcasting is done since other sections have independent code that uses independent registers (which means local section registers will need all registers to use). On the other hand, if a single thread is in use, then all the sections are cooperating on doing useful work for this single thread. The total registers in this case will be only 24, thus registers across the remaining sections (24 entries\*3 sections) can be used to hold copies among each other. This group assignment of the registers can be assigned by the compiler using analysis to determine if matrices could be parallelized and thus assign those matrices that have a chance of executing in parallel non-overlapping group of registers.

Even though the results are being written from all 4 sections, each memory cell in the register file only has ports to support one section. In traditional register files it has to have support for 4 sections, a four fold increase as illustrated in the following example.

The data parallelism in the ULIM is implemented in these architectures on top of the base line format of the ULIM. This is done by allowing each instruction in the ULIM template to be a SIMD/MIMD instruction. In the previous figure each parallel slot can support an internal replicated SIMD structure, while the MIMD is supported by the different parallel/serial slots.

The memory/register or matrix buffer being accessed by an instruction can be viewed differently depending on the intended access nature. For example, the data matrix could be viewed as MIMD of wide data elements, SIMD of small data elements or MIMD of mixed data width SIMD instructions.

In FIG. 5 there are 2 views of the memory/register matrix buffer layout of the data. The one on the right represents orthogonal data elements in each row and column. This supports different combination of MIMD/SIMD data. The view on the left represents different elements on each position of any row, but the column represents the remaining



bits of a larger data size element. For example, the view on the right can represent 4 MIMD instructions each operating on 4 different SIMD bytes, where each is a byte of parallel data elements. While the one on the left represents 4 MIMD instructions, where each of these instructions operates on an element of 32-bits laid out vertically (actual physical layout will differ from the logical representation shown). Moreover, if the view is a MIMD view, then all belong to one single MIMD register of 4 sections, but if the view is non-MIMD view, then those registers are 4 independent registers laid out vertically.

The significance of this memory and register file view and its corresponding execution mode is that it enables the execution unit to morph to execute a wide MIMD/SIMD instruction (glue all register sections to form 4-way MIMD/SIMD), but at the same time the 4 register file sections and corresponding execution units attached can execute as 4 independent units acting on 4 different scalar registers, allowing single and multiple threaded execution within the execution unit at the lowest level of granularity.

The ULIM architecture has fixed size instruction templates similar to VLIW or MIMD templates. In contrast to VLIW or MIMD templates, the ULIM templates allow one to specify both parallel instructions as well as dependent instructions. It follows the same Von Neumann architecture of instructions writing into registers and dependency of instructions within a matrix communicated through register name dependency. One more noteworthy aspect of the ULIM architecture is that each instruction in the matrix has a fixed predetermined location in the matrix and executes in a fixed timing relative to other instructions in the matrix. The width of the ULIM matrix resembles the width of a corresponding VLIW template. Actually, it is always possible to transform serial flow of dependent VLIW instructions into a ULIM template by placing one VLIW instruction at one row of the horizontal rows of the ULIM template. It is not possible to resemble all possible ULIM templates using a flows of VLIW instructions because the ULIM template can include in the same row one complex instruction in one slot and multiple simple instructions in the horizontally adjacent slot.

The advantages of utilizing the matrix architecture composing a matrix of instructions as opposed to executing individual instructions as traditional architectures do are numerous. The following discussion illustrates mechanisms enabling and utilizing the invention's instruction matrix and execution block architecture to build and implement a massively-parallel single processor pipeline.

FIG. 6 illustrates a possible processor pipeline that takes advantage of a ULIM architecture. The invention utilizes a mechanism to simplify the fetch stage 600, branch resolution and decoding stage 608. The fetch unit 600 steps forward while fetching the code on an instruction matrix basis as opposed to an instruction basis. The program counter for such an architecture is incremented by the size of the matrix instead of being incremented by the instruction size. This means that in each cycle a large number of instructions are fetched. To be able to do that, the ULIM matrix will not allow a branch to exist within the ULIM matrix, but branches can exist between ULIM matrices. Branch resolution is done on 2 levels. Within the ULIM matrix, the branches are replaced with conditional execution, conditional moves and prediction. Across matrices, the branches are handled by path prediction and branch coloring. This allows large numbers of instructions grouped into matrices to be moved forward across the pipeline fetch and branch resolution stages.

Executing dependent instructions along side parallel instructions within a single matrix relieves the compiler from the difficulty of constructing all-parallel instructions slot code. It also simplifies the data dependence checking in the score board hardware 602 dispatch unit 604 or hardware scheduling unit. This is achieved by using the matrix number as a utility to enforce score boarding and dependency maintenance between matrices as opposed to using individual registers or individual instructions. In the example of FIG. 7, the score board characterizes the dependency precedence of matrix 8 by only referencing matrix numbers 2, 4 and 5, which means matrix 8 needs to read data results from those matrices. The score board dependency checking does not need to reference the individual register or instruction information to maintain the dependency score boarding. The matrix number carries that information and is enough to maintain correctness of dependency checking. Instructions within a matrix that depend on other matrices can be issued when those matrices are executed. The whole matrix is prevented from being dispatched when the matrices it depends on stalls (e.g., for a cache miss). In one embodiment of the ULIM pipeline implementation, the decode stage 608 is delayed until the stage just before execution, and it is done in parallel with the register read stage 606.

FIG. 8 illustrates one implementation for encoding the instruction template of the ULIM architecture. The key is the encoding and organization of the operands (results and sources registers). The registers specifying instruction results and source operands are specified in a separate section of the ULIM template regardless of the opcode of the instructions and regardless of the fact that the instructions are complex operations or pairs of simple instructions. This matrix format that lists the sources and destinations in an explicit section of the matrix enables the source and destination registers to be extracted independent of the decoding of instructions within the matrix. It will thus be able to implement a delayed decode stage, where actual decoding of the individual instruction opcodes is delayed until just prior to the execution stage and will proceed in parallel with register read to enable execution on the next cycle. It also simplifies dependency resolution and scoreboard implementation.

If a slot includes a complex instruction, such as "Multiply accumulate" (MAC) then it requires 4 sources and writes back two results. If the same slot includes two simple instructions, such as a Logic and an ALU, then each requires 2 sources and writes back one result, which both combined requires 4 sources and generates two results. This makes the number of sources and results independent of the type of operation.

Processor execution hardware as shown in FIG. 4A includes register read and write mechanisms where a matrix operand buffer can assemble the required register sources and destinations based on physical location of where each source will execute on the respected hardware element of the matrix. This reduces the number of read and write ports and the bandwidth requirement on the register file. Using this characteristic of the matrix architecture, the bypassing mechanism is simplified where buffering the sources and/or the destinations in a matrix buffer that is close by or attached to each execution unit can provide shorter access time and larger source and results port bandwidth than a traditional register file, especially in the case of large size register file that needs to support so many individual execution units.

FIG. 9 illustrates the concept of a matrix buffer of the invention. The figure shows the instruction matrix operand buffer 900 connected to the execution units 902. In this

example, the instruction matrix operand buffer **900** buffers sources and destinations for 3 different matrices. Particularly important is the fact that write ports **904** are architected such that each write port writes to different memory cells. This means the matrix operand buffer memory cells are single ported even though there are 6 results that are written at the same time, which is equivalent to a traditional register file that is 6-way ported. Moreover, each write port has a fan out (cells that it needs to drive) equal to the number of matrices in the matrix buffer (only 3 in this example). These features have a lot of advantages in area, power and access speed, making this buffer design very scalable and attractive for high bandwidth high speed register file alternatives.

The following method describes how the registers are written and accessed from the matrix operand buffer. Each matrix is allocated to any available matrix space in the matrix buffer just in time or a short time before the matrix is ready for execution. Remote sources (e.g., sources that are not in other matrices storage within this matrix buffer) that the matrix needs to be able to start executing can be temporarily staged in this matrix storage.

After executing the matrix, results are written into the area allocated for this matrix storage (in one of the 3 matrix locations in the matrix buffer of FIG. 9). Each result is written into the corresponding location accessed by that result write port regardless of the result register number. This location along with the matrix location is communicated to the consuming matrices similar to the score board mechanism shown in FIG. 7, such that each matrix that depends on this matrix will annotate its register sources with the location of the matrix that those sources come from and location of each of the sources within the matrix. The result location within the matrix can be communicated at execution time by the execution hardware or can be embedded in the matrix instruction template alongside the source register number by the software since the matrix template is fixed at compile time.

The basic idea is to build a scalable design of sources and result buffers alongside register files where those buffers are connected to the execution units to allow higher bandwidth and speed by holding data temporary in a matrix location-based identification method establishing an intermediate medium between regular register files and execution units. Values in those matrix buffers can be accessed using the matrix location and the location of the source inside the matrix. For example, register 5 written by matrix 20 can be accessed by recording where that matrix is allocated in the matrix buffer and indexing that matrix's own storage by the entry number that the register 5 result physically occupies inside that matrix. However, after the matrix is de-allocated from the matrix buffer, then all the entries holding register values within the matrix will be written back into the actual register file and accessed by the register number from that moment onwards. The same location-based identification and access method discussed earlier for a register file using a matrix data buffer can be applied to memory accesses using a memory buffer cache.

The matrix architecture can be easily constructed by a compiler if the underlying hardware is uniform and replicated. It also allows for greater efficiency in utilizing the power and silicon area. Here we introduce the concept of a universal unit that is constructed from basic building elements, such as small adders, logical gates, multiplexers, and booth cells.

The architecture of the universal unit allows it to perform all functions/operations inside every single universal unit. This means each universal unit is capable of performing

addition, multiplication, shift, permute, etc. The way it is able to perform such universal functionality is its composition out of basic building elements that are used to perform the simple ALU operations. On the other hand, those simple elements are cascaded to perform the complex operations. It also can process floating point and integer data. The universal unit concept is facilitated by the ideas described above, but it achieves an important advantage by simplifying the scheduling and utilizing the machine throughput to the maximum. In regular architectures, a separate unit is used to perform each operation or function. They share the same port of execution. Thus, when one unit is used, the rest are not utilized. Moreover, the latency in traditional architectures varies among them making it difficult for the scheduler to schedule them. In contrast, in this universal unit, latency is unified for the whole unit and the scheduler sees a symmetric instantiation of the universal unit.

FIG. 10A shows part of this universal unit. Each universal unit can perform different execution units' functions, such as a multiplier, adder, shifter, permuter, etc. This embodiment shows the structure with carry save adders and/or generic adders **1000**. The Unit is composed of basic constructs, each one with 4 rows of adders (could be more or less adders) capable of adding 8 inputs in parallel (4 parallel/serial add operations). These adders are then structured in groups. Each adder in a row can be either connected to the same location adder in the row below (to perform serial ALU operation) or be connected to the adder to its right in the row below to perform a multiply operation. The operations can be  $C*B+A$ , or  $A \text{ OP } B$ , in each row forming 4 parallel/serial ALU operations. In addition, it is possible for these groups of adders to have different data sizes. This structure of adders allows for a tree to perform multiple operand addition, multiplication, multiply accumulate, sum of difference, shifting and rotating. Additionally, multiplexers (not shown in the figure) will align/permute/shift the input or intermediate outputs to obtain the required operation, including shift and permute operations. Booth cells/bit multiply cells **1002** are added to the adders to enable multiplication. Other specific logic, state, memory, or LUT elements are added to provide expanded functionalities.

The universal unit allows the permute/shift unit to be implemented using the same structure that is used to perform the multiply operation or the structure that is used to do the floating point add or floating point multiply accumulate. This advantage allows less routes/area to implement a permute/shift logic. The way the shift or rotate is performed in a multiply structure is by performing a multiplication by  $2.\text{sup.}x$  where  $x$  is the shift count. Performing left shift, right shift or rotate is done by selecting the upper product of the multiply result or lower part or performing the OR function between lower and upper multiply result, respectively.

Each of the elements compose a group of bits using a basic 2-input adder structure. Carry-save-adders can also be built with logic and MUXES. For example, to build  $32*32$  elements, the basic groups can be constructed of 8 bits or 4 bits of basic adders and MUXES, and be able to perform logic functions using the modified carry look ahead adder cell internal logic gates.

FIG. 10B shows the modified basic one bit cell of a carry look-ahead adder used in the 4-bit adder in FIG. 10A to produce either an adder output or a selected logic output. Modification is shown by connections **1010** and two 4:1 multiplexers **1012** that are not in the critical path of the adder. The original adder bit structure (marked as **1014**) includes carry look ahead and sum logic. This figure is for logical representation, actual circuit may differ.

The 4-bit (or 8-bits) groups facilitate the execution of various size SIMD widths as well as 16-bit operations. By the same concept, those 16-bit tiles can be cascaded for larger width data operations, such as 64-bit operations, while still facilitating 8-bit, 16-bit and 32-bit SIMD operations of addition and multiple operand addition, shifting, rotating and multiplication.

The basic concept behind this organization is to be able to execute a combination of parallel and serial instructions on the same structure. For example, the first row of constructs can execute a single 32-bit ALU that can be followed by either a dependent or independent ALU on the 2.sub.nd row and so on. The 4 rows together can execute up to four 32-bit ALU serial/parallel operations or a single 32-bit multiply operation. It can also perform partial width SIMD operations on the sub matrices. The instructions and operands scheduled on this universal unit come as one group, particularly within the matrix data and instructions section.

The ability to pipeline instructions within one cycle is possible using the instruction matrix architecture because we pipeline the dependent instructions to be scheduled within the same cycle or on the following cycle depending on the required frequency. There are multiple ways to take advantage of the ULIM architectures. The system allows for Ultra Large Instruction Matrix scheduling. Parallel instructions as well as dependent instructions are scheduled as a matrix (this is in contrast to VLIW where only parallel instructions can be scheduled). Each instruction or dependent instruction in this matrix can be scalar or SIMD.

The invention may be implemented in any number of ways. For example, multiple dependent instructions may be staged within a clock cycle. In this embodiment of the invention, multiple dependent and parallel instructions can be staged within one clock cycle. Multiple dependent instructions can start within one cycle; this reduces the optimum critical path of the program execution. Multiple dependent instructions may be pipelined with state elements, separating each basic operation in a unit from the following operation. This increases the rate of pipeline execution. However, the power of the design will increase because of clock speed and extra state elements. The state elements may stay constant, but the rate of data pumped through the design increases using wave pipelining.

The invention also includes a Time-Lag Sliced Architecture (TLSA) that accelerates the latency of dependent instructions. The basic idea behind the time lagged sliced architecture is that an operation produces its result digit slice by digit slice. Each slice is produced earlier than the next slice with a time lag between slices. Once the first slice is produced, the next computation can start execution and produce its own slice. The sliced architecture described here is an overall architecture that applies to computational units as well as register files and memories. The architecture applies to all arithmetic, shift, integer and floating point operations.

The TLSA is used to implement an entire system architecture, including memory and computations. The digit slices are not necessarily equal sized digits. The invention can operate with both operands arriving in a digit sliced manner. The invention can implement a booth encoded multiplier, variable shifters, permute engines, as well as floating point adders and multipliers.

In designing execution units, the common methodology is to synchronize the digits or bits of a digit of the output result of an arithmetic/logical or shifter unit as one single output result. This result is either latched into a storage element or staged synchronously as one piece to a receiving element.

However, in this architecture fine grain execution is provided with or without coarse grain synchronous execution. The basic philosophy is to formulate the arithmetic or permute/shift operation in such an organization of time lag logic slices that are staged in time and/or space. The execution hardware is connected in a time delay flow, where early slices execute faster and produce slices of the output results faster, while later slices need more time to execute and produce results in a delay relative to earlier slices. It is worth mentioning that the slices are done on fine granularity of bits/digits within even a single execution unit, like an adder or permuter. This architecture can utilize such organization of digit/bit logic slices to optimize logic timing critical paths and/or number of signal routing paths and/or arca for performing arithmetic, permute, shift, etc. for both integer and/or floating point operations. The slices can be of equal number of bits/digits or different number of bits/digits. One particular advantage of this architecture is the ability to start executing dependent instructions before all the output result slices of the source instruction are finalized.

FIG. 11 illustrates a TLSA unit 1100 where data flows in and out of slices 1102A-1102C. Each slice output has a lag time delay (d) with respect to a previous slice. This time-lag nature allows the unit to be pipelined such that state elements of the different slices are not synchronized to one time, as is typical for row/stage flip flops.

The architecture of FIG. 11 includes a basic adder stage structure that computes basic computation tasks, such as multiple operand addition or sub-block multiplication. Those computations are cascaded using staging elements 1104A-1104C that are not part of the critical path of the basic task. The staging elements can be adders, multiplexers, or logical gates, depending upon the basic computational task that is being sliced. The delay of these staging elements 1104 is minimal and equal to time "d", which is the delay between each slice output and the next slice output.

The staging element is chosen to have the smallest delay possible, as it also establishes the delay of the input operand slices between themselves. The basic computational task in FIG. 11 can use arbitrary levels of adders. Those adders can be any type, e.g., binary or Carry Save Adders (CSA). The architecture of FIG. 11 has the advantage of producing the first slice of the result earlier than the final result. The first slice is forwarded to subsequent operations.

FIG. 12 illustrates one embodiment of the invention where multiple time-lag sliced units are staggered back to back. In this embodiment, each diagonal slice represents an instruction computation unit divided into slices. Here each slice starts execution at a lag in time with respect to a previous slice. Each unit feeds a subsequent unit. This embodiment shows four units back to back. The notation SU1.sub.-0 refers to Slice number 0 of unit number 1. SU4.sub.-7 refers to Slice number 7 of unit number 4.

The architecture shown in FIG. 12 allows (if desired) for multiple TLSA units to process data in a single cycle (or in multiple cycles). A low slice of a first unit feeds the low slice of a second unit and this in turn feeds the third and then the third feeds the fourth, etc. It is also important to notice that in addition to the first slice of the first unit feeding the first slice of the second unit, it also feeds the second slice of its own unit (the 1.sub.st unit). FIG. 12 illustrates the following concepts:

1—Sub-cycle/multi-cycle execution in TLSA [0092] TLSA allows for the execution of the arithmetic/shift/logic operations within one cycle. FIG. 12 illustrates this where 4 units are executed in one cycle, where each slice has a delayed version of that clock cycle. By the same token, the

pipelining can be done at the output of each unit slice (instead of output of 4) to increase the throughput and execute in multiple cycles.

2—Asynchronous/Synchronous/Wave TLSA topologies [0094] The TLSA can be designed in at least 3 different topologies or combinations of those topologies: [0095] A—Asynchronous: where slices' inputs/outputs are communicating with each other within the cycle time without synchronous state elements (e.g., flops). This allows for removal of internal pipeline state elements and enables power friendly slower clock domains. [0096] B—Synchronous: each slice is clocked into a state element (Flop/Latch/domino, etc). This allows for a higher clock throughput and pipelining rate. [0097] C—Wave: in this topology, the data is fed into the unit slice by slice, with the next input data coming at a rate that is faster than the normal pipelining rate. Normal pipeline rate is determined by the maximum time of logic paths between two state elements. Wave pipeline is determined by minimum time of logic paths between two state elements. One interesting combination of topologies is Fine Grain Asynchronous-Coarse Grain Synchronous (FGA-CGS). In this scheme, the TLSA is implemented using time lag slices that are connected asynchronously, where fine grain asynchronous execution is provided with or without coarse grain synchronous execution. The basic philosophy is to formulate the arithmetic or permute/shift operation in such an organization of sliced staged processing where the execution of the different slices of the execution hardware is asynchronously connected in a time delay flow where early slices have less inputs and execute faster and produce their output results faster. Later slices have more inputs, thus need more time to execute and produce results in a delay relative to earlier slices. Each slice is then clocked in a synchronous (or asynchronous) element that has a time lag with respect to the previous slice.

FIG. 12 illustrates multiple TLSA units staggered within one cycle (4 back to back units within 1 clock), at the same time the implementation illustrates a FGA-CGS implementation where unit slices communicate with each others in an asynchronous manner (fine granularity asynchronous), while each slice or back to back slices are synchronized at the output to a state element clock. Each output of the slices may be synchronized to a different clock (delayed version).

The TLSA architecture supports the Ultra Large Instruction Matrix (ULIM) architecture. In this TLSA embodiment, a whole instruction group is scheduled where multiple parallel and dependent instructions are scheduled on instantiation of the TLSA cluster shown above. Each unit can also support SIMD data where duplicates of the data slices are instantiated, but controlled by the same instruction excitation. Additionally, multiples of this assembled structure of SIMD Universal Units can be instantiated horizontally to implement a MIMD architecture on top of a single unit. This way a whole instruction template containing both parallel variations of SIMD instructions and dependent instructions is scheduled in a cycle.

FIG. 13 illustrates a traditional multiplication technique. In particular, each B digit is multiplied against the set of A digits, each of those digits must be available at the multiplication execution unit at the initiation of multiplication. The results are then summed. In contrast, with the present invention, as shown in FIG. 14, operands arrive digit by digit. It can be seen that each row of FIG. 14 represents a partial product of the multiplication operation, but contains only current arriving and previously arrived digits with respect to digit slice arrival times.

To demonstrate how to build the logic structure that uses Booth encoded multiplication to execute the time delay sliced architecture, FIG. 15 illustrates a traditional Booth encoded 32-bit regular multiplier. The Booth encoder groups consecutive multiplier bits together to generate a digit. This grouping can reduce the maximum digit value that represents those bits by considering the signed combinations of the 2 consecutive digits in the number. For example, a 3-bit digit has a maximum value of 7, but by adding 1 to the value of the digit to its left, then the digit 7 is now equivalent to -1. Using signed representations of the digits allows values of those encoded digits to reach a maximum value of  $\frac{1}{2}$  of the original digit values.

FIG. 16 implements the traditional logic structure of the regular Booth multiplication shown in FIG. 15 using radix-4 digits. The selectors 1600A, 1600B choose which multiple of the multiplicand to use out of the possible signed values (0,1,-1,2,-2); the choice is determined by the Booth encoding of the multiplier bits

FIGS. 17 and 18 show the new Booth encoded scheme and the new TLSA logic structure to implement it. Notice that a traditional multiplier has a continuous encoding of the stream of bits, while the TLSA Booth encoder inserts 0's in the stream at the boundaries of the digit slices (in this example a digit of 8 bits). The inserted zeros do not change regardless of the sign of the multiplication (the last 2 bits represent the sign).

FIG. 18 shows how to implement the new modified time-lag sliced Booth encoded 32-bit multiplier. This implementation resembles the generic TLSA structure shown in FIG. 11. FIG. 18 implements sub-multiplication operations illustrated in FIG. 14 and FIG. 17.

The data parallelism in the TLSA is implemented in these architectures on top of the base line format of the TLSA. This is done by allowing each instruction in the TLSA data format of the SIMD/MIMD to be organized in an orthogonal dimension to the TLSA slices. FIG. 19 shows a configuration where a memory/register file data block is accessed by an instruction that can be viewed differently depending on the intended access nature. For example, the data block could be viewed as MIMD of wide data elements, SIMD of small data elements, MIMD of mixed data width SIMD instructions, etc. FIG. 19 illustrates an architecture to execute such combinations. The slices within the unit can operate independently to perform sub-operations. For example, each slice of 8 bits can perform independent 8-bit multiplication, while the group of slices that construct one 32-bit multiplier unit can also be operated as a 4-way SIMD byte multiplier. On the other hand, the group of units can be operated as a MIMD multiplier.

FIG. 20 illustrates a memory that is accessed in a sliced manner. In traditional memory architectures, a single operand (e.g., a 64-bit integer or floating point operand) is fetched as a whole. After the address decoding is finished, all the bits are read through the read port, which has to buffer the read enable across the whole width of the operand size in memory. In the TLSA architecture, after the decoding of the address occurs, the data read and/or write occurs on a time lag model of a slice following a previous slice with a time delay in between. The benefit of this model is the fast memory response when it is not necessary to decode and drive the whole data width at once.

FIG. 21 illustrates a TLSA architecture with a permute/shift unit that takes advantage of the time lag between data slices. This advantage allows faster time to produce early result slices and/or less routes/area to implement a permute/shift logic. In FIG. 21, a right shifter is constructed to take

the time lag arrival of a 32-bit operand sliced in 8-bit digits. The first slice (digit) of the 32-bit input arrives at time T.sub.0, while the last slice arrives at time T.sub.0+3d, where d is one MUX delay. The bits (0 to 5) shown vertically on the right side represent the shift count (maximum of 32, any value >32 generates an output of zero, basically all data is shifted out). The execution starts with the arrival of the first low order digit from the right side of the shifter. The unit then waits for the next input digit to arrive. One of the digits is selected to the lower digit position depending on the value of bit 3 of the shift count, which will determine if the number will be shifted by 8 bits to the right. Then the next most significant digit arrives and a choice is made to select this new digit or pass the data that was selected in the upper multiplexer levels using the next bit in the shift count and so on. Any multiplexer position where the shift count will zero out that location will implement a zero override to its output. When the last digit arrives, it goes through the least number of multiplexer levels and thus will have a minimum delay "d" with respect to the previous digit to enable a fast propagation of the last digit to the output.

A left shifter can be constructed with the structure of FIG. 21 mirrored about a vertical line where left slices have larger stacks of multiplexers and right slices have smaller stacks of multiplexers. The most significant digit passes through the least number of multiplexer levels.

The sliced architecture universal unit can be a universal unit similar to the one described in FIGS. 10A-10B. It uses the same techniques of the sliced architecture (TLSA) and/or fine grain asynchronous concepts. It performs all functions/operations inside every single universal unit. This means each universal unit is capable of performing addition, multiplication, shift, permute, etc. The way it is able to perform this universal functionality with low latency is the ability to process the individual slices one at a time in a time lag fashion. It also can process floating point and integer data. The universal unit concept is facilitated by the ideas described above, but it achieves an important advantage by simplifying the scheduling and utilizing the machine throughput to the maximum. In regular architectures, a separate unit is used to perform each operation or function. They share the same port of execution. Therefore, when one unit is used the rest is not utilized. Moreover, the latency varies among them making it difficult for the scheduler to schedule them. In contrast, in this universal unit, latency is unified for the whole unit and the scheduler sees a symmetric instantiation of the universal unit.

Each universal unit can perform different execution units' functions, such as a multiplier, adder, shifter, etc. In addition, it is possible for these slices to have different data sizes. In this particular illustration, each slice is larger in data width than the previous slice. This structure of adders allows for a tree of slices to perform multiple operand addition, multiplication, multiply accumulate, sum of difference, etc. Multiplexers (not shown in the figure) align/permute/shift the input or intermediate outputs to obtain the required operation, including shift and permute operation using the universal structure of adders/multiplexers. Booth cells/bit multiply cells are added to the adders to enable multiplication. Other specific logic, state, memory, or LUT elements are added to provide expanded functionalities.

The ULIM architecture can be time sliced using the disclosed TLSA techniques. One other way to construct a Universal unit is to configure it as a Floating point multiply accumulate unit (MAC). The functions used in building this unit are Multiplier, Right Shifter, Adder, and Left shifter. Such a structure as disclosed in FIG. 22. A Universal unit

can utilize such a structure to perform any one or combinations of those functions that construct the FP-MAC.

Each one of those functions has been described earlier and therefore can be implemented individually as TLSA structures and then be combined to operate as a floating point multiple accumulate TLSA structure. Such a structure can also operate as a consecutive sliced ALU or multiply followed by an ALU or shift, etc.

An embodiment of the present invention relates to a computer storage product with a computer-readable medium having computer code thereon for performing various computer-implemented operations. The media and computer code may be those specially designed and constructed for the purposes of the present invention, or they may be of the kind well known and available to those having skill in the computer software arts. Examples of computer-readable media include, but are not limited to: magnetic media such as hard disks, floppy disks, and magnetic tape; optical media such as CD-ROMs, DVDs and holographic devices; magneto-optical media; and hardware devices that are specially configured to store and execute program code, such as application-specific integrated circuits ("ASICs"), programmable logic devices ("PLDs") and ROM and RAM devices. Examples of computer code include machine code, such as produced by a compiler, and files containing higher-level code that are executed by a computer using an interpreter. For example, an embodiment of the invention may be implemented using Java, C++, or other object-oriented programming language and development tools. Another embodiment of the invention may be implemented in hard-wired circuitry in place of, or in combination with, machine-executable software instructions.

The foregoing description, for purposes of explanation, used specific nomenclature to provide a thorough understanding of the invention. However, it will be apparent to one skilled in the art that specific details are not required in order to practice the invention. Thus, the foregoing descriptions of specific embodiments of the invention are presented for purposes of illustration and description. They are not intended to be exhaustive or to limit the invention to the precise forms disclosed; obviously, many modifications and variations are possible in view of the above teachings. The embodiments were chosen and described in order to best explain the principles of the invention and its practical applications, they thereby enable others skilled in the art to best utilize the invention and various embodiments with various modifications as are suited to the particular use contemplated. It is intended that the following claims and their equivalents define the scope of the invention.

What is claimed is:

1. An execution unit to execute instructions using a time-lag sliced architecture (TLSA), the execution unit comprising:

a first computation unit, wherein the first computation unit includes a plurality of logic slices arranged in order, wherein each of the plurality of logic slices of the first computation unit except a lattermost logic slice is coupled to an immediately following logic slice to provide an output of that logic slice to the immediately following logic slice, wherein the immediately following logic slice is to execute with a time lag with respect to its immediately previous logic slice, wherein the plurality of logic slices of the first computation unit are to collectively perform a first operation, wherein a result of the first operation is to be generated slice by slice with time lags between the generation of each slice; and

a second computation unit, wherein the second computation unit includes a plurality of logic slices arranged in order, wherein each of the plurality of logic slices of the second computation unit except a lattermost logic slice is coupled to an immediately following logic slice to provide an output of that logic slice to the immediately following logic slice, wherein the immediately following logic slice is to execute with a time lag with respect to its immediately previous logic slice, wherein each of the plurality of logic slices of the second computation unit is coupled to a corresponding logic slice of the plurality of logic slices of the first computation unit to receive an output of the corresponding logic slice of the first computation unit, wherein the plurality of logic slices of the second computation unit are to collectively perform a second operation that is dependent upon the result of the first operation, wherein a result of the second operation is to be generated slice by slice with time lags between the generation of each slice, wherein at least one logic slice of the plurality of logic slices of the second computation unit is to begin execution before every slice of the result of the first operation is generated.

2. The execution unit of claim 1, wherein the first computation unit and the second computation unit are configured to access data in a memory in units of data slices with time lags between accesses of data slices.

3. The execution unit of claim 1, wherein the first computation unit and the second computation unit are configured to execute in a single clock cycle.

4. The execution unit of claim 1, wherein each logic slice is configured to produce a single digit as its output.

5. The execution unit of claim 1, wherein logic slices are configured to communicate with other logic slices in an asynchronous manner without the use of synchronous state elements.

6. The execution unit of claim 1, wherein logic slices are configured to be clocked into state elements, and wherein logic slices are configured to communicate with other logic slices in a synchronous manner using the state elements.

7. The execution unit of claim 1, wherein logic slices are configured to communicate with other logic slices of the same computation unit in an asynchronous manner without the use of synchronous state elements, and wherein logic slices are configured to be synchronized with corresponding logic slices of a different computation unit using a state element clock.

8. The execution unit of claim 1, wherein the first computation unit and the second computation unit implement part of a Booth encoded multiplier.

9. The execution unit of claim 1, wherein the first computation unit and the second computation unit implement part of a left shifter or a right shifter.

10. A processor to execute instructions using a time-lag sliced architecture (TLSA), the processor comprising:

- a memory to store data; and
- an execution unit communicatively coupled to the memory, wherein the execution unit includes a first computation unit and a second computation unit, wherein the first computation unit includes a plurality of logic slices arranged in order, wherein each of the

plurality of logic slices of the first computation unit except a lattermost logic slice is coupled to an immediately following logic slice to provide an output of that logic slice to the immediately following logic slice, wherein the immediately following logic slice is to execute with a time lag with respect to its immediately previous logic slice, wherein the plurality of logic slices of the first computation unit are to collectively perform a first operation, wherein a result of the first operation is to be generated slice by slice with time lags between the generation of each slice, and wherein the second computation unit includes a plurality of logic slices arranged in order, wherein each of the plurality of logic slices of the second computation unit except a lattermost logic slice is coupled to an immediately following logic slice to provide an output of that logic slice to the immediately following logic slice, wherein the immediately following logic slice is to execute with a time lag with respect to its immediately previous logic slice, wherein each of the plurality of logic slices of the second computation unit is coupled to a corresponding logic slice of the plurality of logic slices of the first computation unit to receive an output of the corresponding logic slice of the first computation unit, wherein the plurality of logic slices of the second computation unit are to collectively perform a second operation that is dependent upon the result of the first operation, wherein a result of the second operation is to be generated slice by slice with time lags between the generation of each slice, wherein at least one logic slice of the plurality of logic slices of the second computation unit is to begin execution before every slice of the result of the first operation is generated.

11. The processor of claim 10, wherein the execution unit is configured to access the data stored in the memory in units of data slices with time lags between accesses of data slices.

12. The processor of claim 10, wherein the first computation unit and the second computation unit are configured to execute in a single clock cycle.

13. The processor of claim 10, wherein each logic slice is configured to produce a single digit as its output.

14. The processor of claim 10, wherein logic slices are configured to communicate with other logic slices in an asynchronous manner without the use of synchronous state elements.

15. The processor of claim 10, wherein logic slices are configured to be clocked into state elements, and wherein logic slices are configured to communicate with other logic slices in a synchronous manner using the state elements.

16. The processor of claim 10, wherein logic slices are configured to communicate with other logic slices of the same computation unit in an asynchronous manner without the use of synchronous state elements, and wherein logic slices are configured to be synchronized with corresponding logic slices of a different computation unit using a state element clock.

17. The processor of claim 10, wherein the execution unit implements a Booth encoded multiplier.

18. The processor of claim 10, wherein the execution unit implements a left shifter or a right shifter.