

(No Model.)

# J. P. JOHNSON. BELLOWS.

No. 582,139.

Patented May 4, 1897.

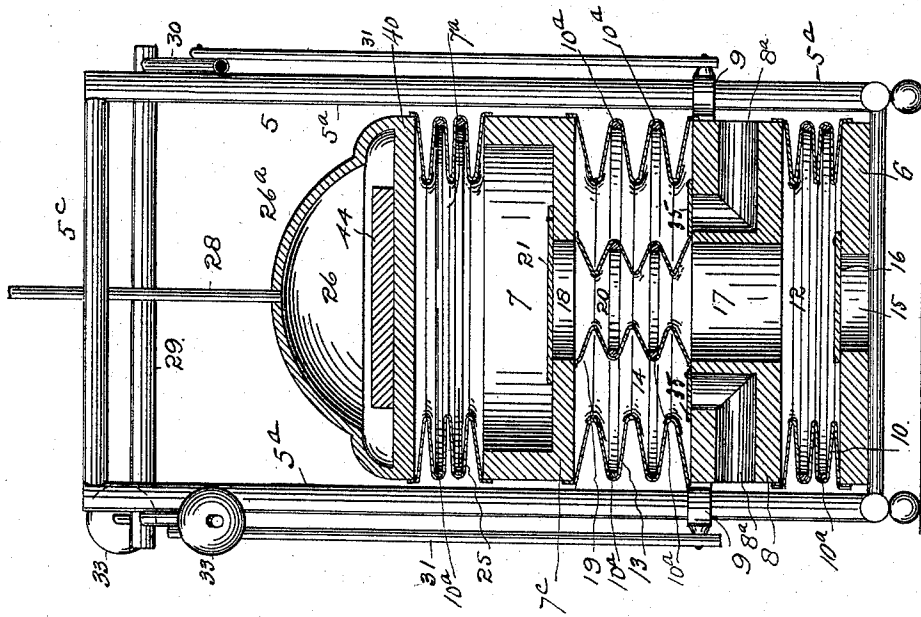

FIG. 2.

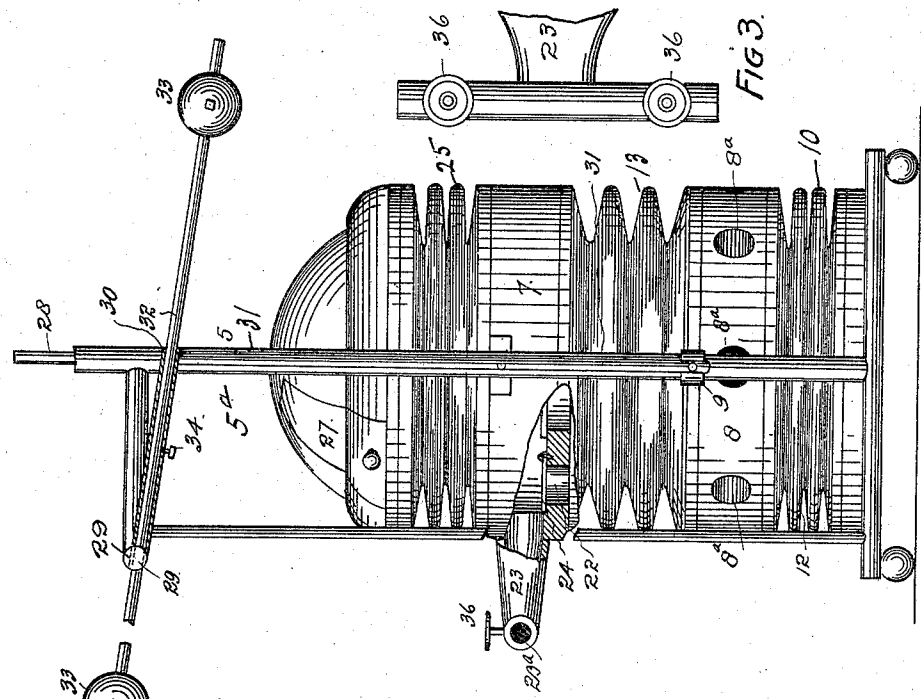

FIG. 1.

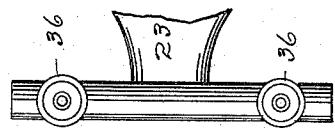

FIG. 3.

Witnesses  
*G. J. Dillaudet.*  
*Chas. E. Lawson*

Inventor  
*J. P. Johnson*  
 By his Attorney  
*J. B. Zien*

# UNITED STATES PATENT OFFICE.

JOHN PETER JOHNSON, OF DENVER, COLORADO.

## BELLOWS.

SPECIFICATION forming part of Letters Patent No. 582,139, dated May 4, 1897.

Application filed April 13, 1896. Serial No. 587,356. (No model.)

*To all whom it may concern:*

Be it known that I, JOHN PETER JOHNSON, a citizen of the United States of America, residing at Denver, in the county of Arapahoe and State of Colorado, have invented certain new and useful Improvements in Bellows; and I do declare the following to be a full, clear, and exact description of the invention, such as will enable others skilled in the art to which it appertains to make and use the same, reference being had to the accompanying drawings, and to the figures of reference marked thereon, which form a part of this specification.

My invention relates to improvements in bellows, and my chief object is to prevent the possibility of explosions in an apparatus of this class.

It is well known that in the case of ordinary bellows used to blow a furnace-fire there is always some back draft from the furnace as the bellows is opened. By reason of this back draft gases are drawn into the bellows. These gases are liable to ignition by a spark from the fire, thus causing an explosion which may result in loss of life as well as in destruction of property.

My further object is to provide a bellows which shall be simple in construction, economical in cost, and reliable, durable, and efficient in use; and to these ends the invention consists of the features hereinafter described and claimed, all of which will be fully understood by reference to the accompanying drawings, in which is illustrated an embodiment thereof.

In the drawings, Figure 1 is a side elevation, partly in section, of my improved bellows. Fig. 2 is a vertical longitudinal section taken through the same. Fig. 3 is a fragmentary top view illustrating the blast-pipe and controlling-valves.

Similar reference-characters indicate corresponding parts in the views.

Let the numeral 5 designate a suitable upright frame upon which is mounted the stationary base 6 and the stationary partition 7<sup>c</sup>, forming the bottom of the chamber 7. This partition is located a suitable distance above the base. Between the base 6 and the partition 7<sup>c</sup> is a vertically-movable partition 8, to which are attached guides 9, surrounding

two vertical frame-bars 5<sup>a</sup>, located on diametrically opposite sides of the machine. The partition 8 is attached to the base 6 by means of a flexible connection 10, forming an expandible and collapsible chamber 12. The partition 8 is also attached to the partition 7<sup>c</sup> by a flexible connection 13 of substantially the same construction as the connection 10. The connection 13 incloses a chamber 14 of the same character as the chamber 12.

The base 6 is provided with a central port 15, which communicates with the outer air. This port 15 is controlled by a suitable flap-valve 16, opening upward into the chamber 12, thus allowing the air to enter said chamber, but preventing its return. There is an opening 17 through the center of the horizontal partition 8 and a similar opening 18 in the bottom of the chamber 7. These openings 17 and 18 are connected by some suitable flexible fabric 19, which forms a passage-way 20 through the center of the chamber 14. The opening 18 is controlled by a suitable flap-valve 21, opening upward. The bottom of the chamber 7 is also provided with an opening 22, leading from the chamber 14 into the chamber 7 and located directly in front of the blast-pipe 23, through which the air makes its escape to the furnace. This opening 22 is controlled by a flap-valve 24, opening upward into the chamber 7. The partition 8 is provided with a number of ports 8<sup>a</sup>, which lead from the outer air to the chamber 14. These ports are controlled by flap-valves 35, opening upward into the chamber 14.

The apparatus is provided with a top plate 40, which is connected with a vertical flange on the partition 7<sup>c</sup> by means of a flexible connection 25, thus making the chamber 7 expandible and collapsible. The plate 40 forms the bottom for a chamber 26, having a covering 26<sup>a</sup>, provided with a hinged section 27, which may be opened at will for the purpose of placing weights in the chamber 26. To the roof of the chamber 26 is attached a guide-rod 28, which passes through an aperture formed in the top bar 5<sup>c</sup> of the frame.

Mounted upon the top part of the framework is a rock-shaft 29, to which are made fast two hollow cranks 30, whose extremities remote from the rock-shaft are suitably connected with pitmen 31, one being located on

each side of the apparatus. The lower extremities of these pitmen are respectively connected with the guides 9.

A hand-lever 32 for operating the bellows 5 may be passed through either of the hollow cranks 30. This lever is provided with detachable weights 33, which are also adjustable. The lever is held in place by a set-screw 34. By loosening the set-screw and 10 detaching one of the weights the lever may be removed from one crank and inserted in the other. By means of this feature the user may operate the bellows from either side, as may be more convenient.

15 The blast-pipe 23 is T-shaped and has two openings 23<sup>a</sup> for the escape of air. These openings are controlled by stop-cocks 36. Hence one apparatus may be made to blow two fires.

20 The operation of the bellows will now be described, assuming that the parts are in the relative positions shown in Fig. 1. As the extremity of the lever 32 located farther to the left in said view is depressed the partition 25 will be raised through the instrumentality of the rock-shaft 29, the cranks 30, the pitmen 31, and the guides 9. As this partition is raised the chamber 12 is expanded and the chamber 14 contracted. As this occurs the 30 valve 16 opens and the air enters the chamber 12 via the port 15, while the air is forced out of the chamber 14 into the chamber 7 via the port 22, the valve 24 opening upward to permit this result. Again, as the movement of 35 the lever 32 is reversed the chamber 12 is contracted and the chamber 14 expanded, with the result that the air is forced out of the chamber 12 via the port 17, the passage-way 20, and the port 18 into the chamber 7, while 40 the air enters the chamber 14 via the ports 8<sup>a</sup>. As the air enters the chamber 7 the weight on the plate 40 in the chamber 26 aids in forcing the air out of said chamber via the blast-pipe 23. As the air is forced out of the 45 chambers 12 and 14 the valves 16 and 35, con-

trolling the respective inlet-ports of the said chambers, are closed. It will thus be seen that as the lever 32 is operated the air is forced into the chamber 7 in an uninterrupted 50 current. While the lever is making one movement this current proceeds from the chamber 12, but while the lever is making the reverse movement the current passes from the chamber 14. Hence during the operation of the 55 bellows the air is passing out of the blast-pipe in a continuous current, and there can be no back draft from the furnace, and consequently no possibility of explosion in the bellows through the ignition of confined furnace-gases. 60

A weight 44 is shown in the chamber 26 and resting on the top plate 40. The gravity of the weight on this top plate may be regulated at will.

The flexible parts 10, 13, 19, and 25 are 65 preferably made of heavy leather, reinforced by ribs 10<sup>a</sup>.

Having thus described my invention, what I claim is—

The combination with a bellows having a 70 movable partition, and a frame provided with upright side bars, guides slidingly mounted on the side bars, and to which guides the movable partition is attached, a rock-shaft 75 mounted on the upper part of the frame, two hollow cranks respectively mounted on the extremities of the rock-shaft, two pitmen whose upper extremities are connected with the cranks, their lower extremities being connected with the vertically-sliding guides, and 80 a hand-lever adapted to be inserted in and connected with either hollow crank at will, substantially as described.

In testimony whereof I affix my signature in the presence of two witnesses.

JOHN PETER JOHNSON.

Witnesses:

CHAS. E. DAWSON,  
ALFRED J. O'BRIEN.