

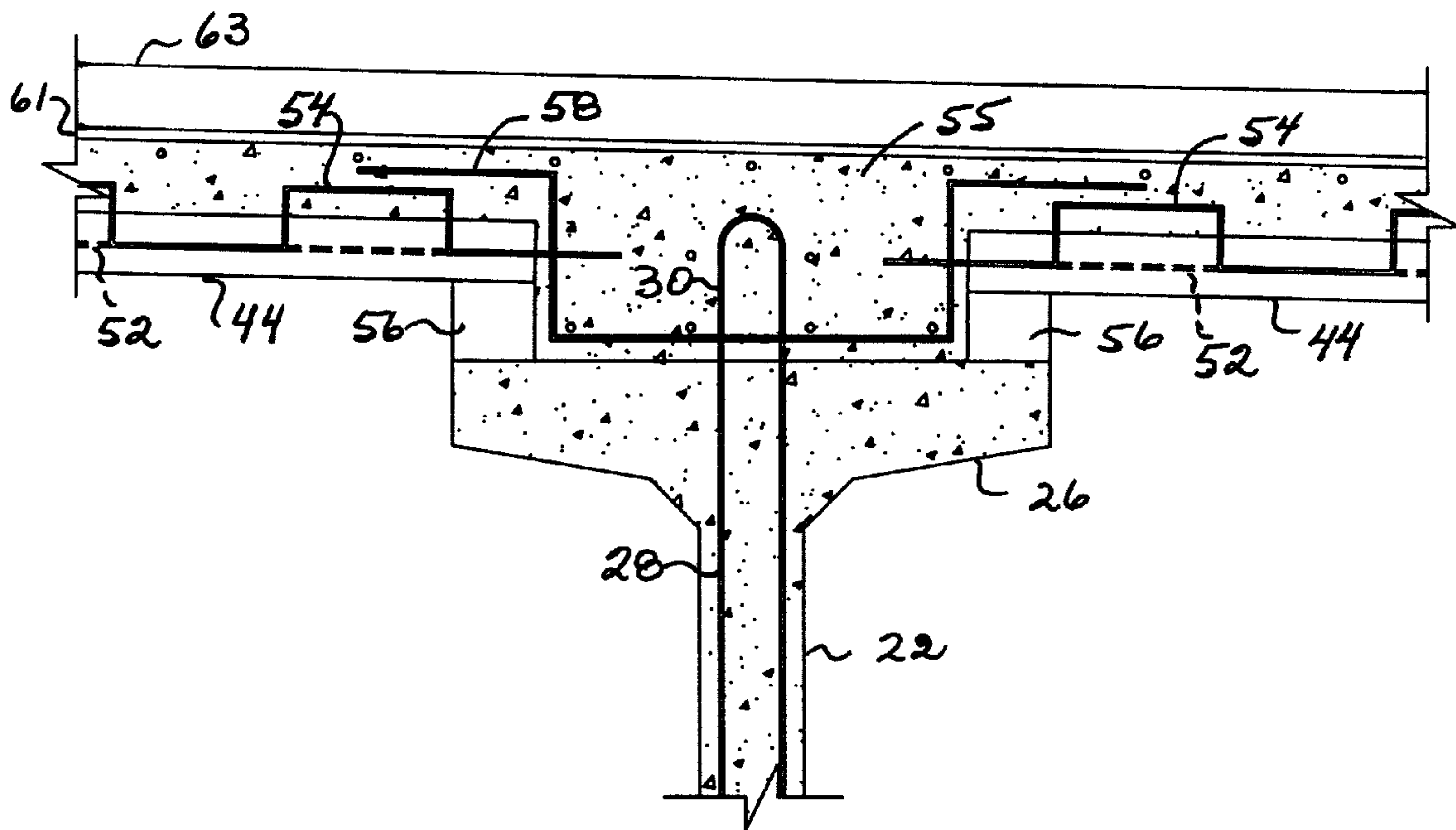

(22) Date de dépôt/Filing Date: 2000/04/20  
(41) Mise à la disp. pub./Open to Public Insp.: 2001/10/20

(51) Cl.Int.<sup>7</sup>/Int.Cl.<sup>7</sup> E01D 2/02  
(71) Demandeur/Applicant:  
BOT CONSTRUCTION LIMITED, CA  
(72) Inventeur/Inventor:  
BOT, STEVEN ROBERT, CA  
(74) Agent: GOWLING LAFLEUR HENDERSON LLP

(54) Titre : PONT AVEC TABLIER DE BETON AYANT UNE DALLE PREFABRIQUEE  
(54) Title: BRIDGE STRUCTURE WITH CONCRETE DECK HAVING PRE-CAST SLAB



(57) Abrégé/Abstract:

A precast concrete slab for forming a deck in a bridge superstructure has a chamfer on forward and trailing edges so that adjacent slabs can mate. The slab is reinforced with bars which protrude laterally from the slab on opposite sides and which, in use, extend over support beams. Selected bars are formed in a castellated shape of which inverted U-shaped portions extend above the surface of the precast concrete slab. Conveniently, the U-shaped portions anchor a concrete topping which is poured over the slabs at a bridge site and also provide locations for hooking a crane used to transport the slab at a site.

**ABSTRACT**

A precast concrete slab for forming a deck in a bridge superstructure has a chamfer on forward and trailing edges so that adjacent slabs can mate. The slab is reinforced with bars which protrude laterally from the slab on opposite sides and which, in use, extend over support beams. Selected bars are formed in a castellated shape of which inverted U-shaped portions extend above the surface of the precast concrete slab. Conveniently, the U-shaped portions anchor a concrete topping which is poured over the slabs at a bridge site and also provide locations for hooking a crane used to transport the slab at a site.

## **BRIDGE STRUCTURE WITH CONCRETE DECK HAVING PRECAST SLAB**

### **Field of the Invention**

**[0001]** This invention relates to a bridge superstructure, and more particularly relates to the construction of a concrete deck made of precast concrete slabs and which rest on a series of precast concrete beams or steel girders.

### **Background of the Invention**

**[0002]** Typically, the construction of bridges is a time consuming task where precast concrete support beams or steel girders are erected on location and customized form work is created between the beams in order to support concrete to be poured onto the form work. To some extent, the form work which is made from wood beams and plywood may be pre-fabricated but all the components must be trimmed to their final dimensions and assembled on location. After the poured concrete deck has set, the form work is removed. In order to minimize the danger of materials falling from scaffolding onto an underlying roadway and to minimize disruptions to traffic flow, such form work is typically erected and dismantled at night when the roadway is less busy and the roadway may be closed to general circulation.

**[0003]** A system for building a concrete deck with precast concrete slabs is described in US Patent Number 4,604,841. The slabs are reinforced with prestressed reinforcement rods which must extend throughout the width of the deck across support beams and through adjacent slabs. Because the precast slabs and prestressed rod system is unwieldy, the invention described in US Patent Number 4,604,841 proposes a precast slab having a width which corresponds to the width of the bridge and which has prestressed reinforcement rods extending throughout the width of the precast slab. The sheer size of such a slab is in itself a deterrent to its use since it is very heavy and difficult to manipulate.

**[0004]** Another problem which is encountered with decks constructed with precast slabs occurs at the joint between slabs placed end to end along the length of the bridge. Because of imperfections inherent in pouring concrete, and the likelihood of slabs becoming damaged during transportation, particularly at the bottom edges of slabs having large dimensions, the forward and trailing edges often do not mate. As a result, some form of sealant must be

applied to the joints between slabs before pouring a concrete topping to build the deck to the required thickness.

[0005] An object of this invention is to simplify the construction of a bridge superstructure in order to minimize the time required for creating a concrete deck and to minimize the safety hazards to both the patrons using the roadway and the personnel who erect such structures, usually at night, when visibility is poor.

### **Summary of the Invention**

[0006] In accordance with this invention, there is provided a precast concrete slab which is dimensioned to locate between beams and which is reinforced with steel rods at predetermined spaced locations, a selected number of said reinforcement bars extending upwardly above the surface of the precast concrete slab to define anchors for securing a concrete topping to be poured onto the precast concrete slab.

[0007] The reinforcement bars comprising said anchors are preferably bent into a castellated shape of which inverted U-shaped portions extend above the surface of the precast concrete slab.

[0008] Preferably, the slabs are shaped to abut on each other end to end and have chamfered bottom edges to ensure mating of the upper edges on slabs disposed adjacent to one another.

[0009] In accordance with another aspect of the invention, a bridge is constructed by first erecting support beams at predetermined spaced locations and by placing screed adjusters comprising high density expanded polystyrene foam strips along opposed lateral edges of the support beams, locating precast slabs made according to the invention on said screed adjusters to bridge the spaces defined between the beams and form a deck, and pouring a fresh concrete topping over said deck to build the deck to a final pre-determined thickness in accordance with prevailing design considerations. Preferably, the precast slabs are coupled to anchors in the support beams with deck reinforcement bars and ties securing the deck reinforcement bars to the beam anchors and to the slab reinforcement bars.

### **Brief Description of Drawings**

[0010] In order that the invention be more clearly understood, a preferred embodiment thereof is described below with reference to the accompanying drawings, in which:

Fig. 1 is a schematic side elevation view of a prior art bridge construction including lumber framework;

Fig. 2 is a schematic side elevation view of a bridge construction made using a precast concrete slab in accordance with the invention;

Fig. 3 is a perspective view of a precast concrete slab in accordance with the invention spanning a pair of beams to form a deck;

Fig. 4 is a plan view of the precast concrete slab of Fig. 3;

Fig. 5 is a cross-sectional view on line 5-5 of the slab of Fig. 3;

Fig. 6 is a side elevation view of a pair of precast concrete slabs disposed end to end;

Fig. 7 is a detailed view of circled area 7 of Fig. 6 with a concrete topping, waterproof sheeting and asphalt applied to the surface of the concrete slabs;

Fig. 8 is a front elevation view of the deck of Fig. 3 with a concrete topping, waterproof sheeting and asphalt applied to the surface of the concrete slabs;

Fig. 9 is a top plan view of a single span for a bridge superstructure showing a precast slab layout;

Fig. 10 is a top plan view of a deck slab of Fig. 9 and drawn to a larger scale;

Fig. 11 is a top plan view of a deck slab of Fig. 9 and drawn to a larger scale;

Fig. 12 is a top plan view of a deck slab of Fig. 9 and drawn to a larger scale;

Fig. 13 is an end elevation view of a bridge superstructure showing a sidewalk;

Fig. 14 is an isometric view showing the shape of a precast concrete slab in accordance with the invention;

Fig. 15 is a front side view of the slab of Fig. 14;

Fig. 16 is a top plan view of the slab of Fig. 14; and

Fig. 17 is a right side elevation view of the slab of Fig. 14.

### **Description of Preferred Embodiment with Reference to Drawings**

[0011] A typical bridge construction made in accordance with the prior art is illustrated in Fig. 1 in which the bridge superstructure is generally indicated by reference numeral 20. The bridge superstructure 20 comprises a series of support beams 22 which, in this case, are made of precast concrete and which generally have an I-shaped cross-section defining a wide support base 24 and a wide deck platform 26. The support beams 22 are reinforced with reinforcement bars 28 disposed at spaced intervals along the length of the beams 22 and bent into an inverted U-shape with a loop 30 extending above the surface of the deck platform 26 and defining a beam anchor.

- [0012]** Typically form work 32 made in accordance with the prior art spans the separation between the beams 22 and is constructed from lumber in order to provide a platform onto which concrete is poured to form a deck 34. The form work 32 comprises 2x12 doubled bearers 36 supported at each end by steel hangers 38 spaced at approximately three foot intervals on support beams 22. The 2x12 bearers 36 in turn support a plurality of 4x4 beams 40 lying transversely to the 2x12 bearers 36 and spaced a maximum of 400 millimetres apart. The form work 32 is completed a plywood sheet 42, 17 millimetres in thickness.
- [0013]** All of this form work 32 is trimmed and assembled on location. Once the concrete to form the deck 34 has been poured onto the form work 36 and over the beams 22, and it has set, the form work 32 is removed. The deck is normally completed by laying waterproof sheeting over the concrete, and asphalt (not shown).
- [0014]** In accordance with the invention, the form work 32 is replaced by a precast concrete slab generally indicated by numeral 44 in Fig. 2 of the accompanying drawings. Other features of the resulting bridge superstructure 46 which are similar to the prior art bridge superstructure 20 of Fig. 1 are identified by like numerals.
- [0015]** A detailed drawing of the precast slab 44 is shown in Fig. 3 and essentially comprises a rectangular slab which typically will have a length of about 3 metres and a width of 2050 millimetres with a thickness of 90 millimetres. As will be seen more clearly in Figs 14 to 17 the top face 48 of the slab is orthogonal to its sides whereas the bottom face 49 is somewhat recessed to define a 20 millimetre chamfer 50 (shown in more detail in Fig. 7 on forward and trailing edges for the slab). A plurality of slab reinforcement bars 52, 53 extend throughout the width and length respectively of the slab 44 in a grid pattern shown in ghost outline in Fig. 4 of the accompanying drawings. The reinforcement bars 52 which extend across the width of the slab 44 have extremities which protrude laterally from both sides of the slab over the deck platform 26 of the associated support beams 22. Since the slab reinforcement bars 52 are not pre-stressed, they may be trimmed and cut, as necessary, for the slabs 44 to follow the contour of an underlying roadway (see Fig. 9).
- [0016]** A number of the slab reinforcement bars 52 extend upwardly above the top face 48 of the precast concrete slab 44 to define slab anchors 54 for securing a concrete topping 55 (Fig. 8) to be poured onto the precast concrete slabs 44 and form the deck 34. The reinforcement bars 52 comprising the slab anchors 54 are preferably bent into a castellated shape of which inverted U-shaped portions extend above the top face 48 of the precast concrete slab 44, as

will be seen in Figs. 4 to 6, where the ghost outline shows portions of the slab reinforcement bars 52 which are imbedded in the precast slab and the solid lines show slab reinforcement bars which are exposed until the concrete topping 55 is poured.

- [0017] The precast concrete slabs 44 are placed end to end adjacent one another to extend along the length of the bridge as shown in Figs. 6 and 9. Where the forward and trailing ends of adjacent slabs 44 meet, the upper edges mate as shown in Fig. 7 and operate to provide a flush surface upon which concrete may be poured without having to use sealants 57 or fillers between adjacent slabs other than in exceptional circumstances in selected locations. When viewed from the bottom, the chamfers 50 of abutting adjacent slabs 44 give the deck 34 a grooved appearance and architectural appeal.
- [0018] The construction of a bridge superstructure 46 is schematically shown in Fig. 8 and comprises erection of the support beams 22 at predetermined spaced locations and placing screed adjusters 56 comprising high density expanded polystyrene foam strips along opposed edges of the support beam deck platform 26. The polystyrene foam bedding material is typically 50 millimetres wide and will have a height of 40 millimetres to 125 millimetres to suit the screed elevations. The precast concrete slab 44 is lowered by crane over the support beams 22 so as to rest on the screed adjusters 56. Conveniently, the slabs 44 may be transported to a bridge site by hooking into the slab anchors 54. Once the precast concrete slabs 44 are installed, which can be done very quickly and with a minimum of preparation, wet concrete may be poured to form a concrete topping 55. It will be appreciated that the slab anchors 54 serve to mechanically lock the freshly poured concrete of the concrete topping 55 to the precast concrete slabs 44.
- [0019] The concrete topping 55 extends to a greater depth over the support beams 22 where it is locked by the laterally extending slab reinforcement bars 52 and by the beam anchors or loops 30. Deck reinforcement bars (not shown) are placed over the precast slabs 44 before pouring the concrete topping 55 and will be supported by a number of base structures commonly called a chair and which are placed on the precast slabs 44. Special deck reinforcement bars 58 are used to couple the precast concrete slabs 44 to the beam anchors 30 and comprise lengths of rod having ends which extend horizontally on opposite sides of a support beam 22 over the associated precast slabs 44 and a central portion which reaches the deck platform 26 of the associated support beam 22. Such deck reinforcement bars 58 are placed to cross the laterally extending slab reinforcement bars 52 and beam anchors 30.

Ties (not shown) are provided to secure the deck reinforcement bars 58 to the beam anchors 30 and slab reinforcement bars 52. In this way, the invention obviates the need for prestressing the reinforcement provided in the precast slabs.

- [0020]** The slab layout for a typical bridge span is shown in Fig. 9 where the support beams 22 are shown in chain dotted lines and comprise eight in number and spanning a pair of oppositely disposed abutments 60 extending across the width of the bridge. It will be understood that a bridge may comprise a single span as illustrated or a number of spans disposed end to end and supported on a corresponding number of piers in the associated bridge substructure. Typically, a single span, as illustrated, is sufficiently long to bridge two lanes of highway traffic running transversely below the bridge.
- [0021]** The precast slabs 44 are shown in solid lines disposed end to end with forward and trailing edges abutting one another along the length of the associated support beams 22. The deck slabs 44 identified by the numeral 2 have rectangular upper and lower faces, as shown in Fig. 10 and occupy most of the area of the span. Custom formed deck slabs 44 identified by the numerals 1 and 3 and shown in Figs. 11, and 12 are disposed at the ends of the span and have respective forward and trailing edges which are not orthogonal to their lateral edges. This layout would be typical in bridges where the abutments 60 are not orthogonal to the support beams 22 as a result of changes in the terrain or topography in the area where the bridge is being erected. The deck slabs identified by numerals 1 and 3 could also be cut to the required shape on location, the reinforcement bars not being prestressed.
- [0022]** The deck 34 is completed by laying waterproof sheeting 61 over the concrete topping 55, and asphalt 63 (Figs. 7 and 8).
- [0023]** It will be appreciated that the concrete topping 55 formed on the outer support beams 22a, 22b is roughened as shown in Fig. 13 on a top surface thereof prior to a second concrete pour for forming a sidewalk 62, as is commonly done. The outer edges of the sidewalk 62 support an upwardly extending barrier wall 64 or railings for protecting motorists and pedestrians from falling off the bridge.
- [0024]** Those skilled in the art will appreciate that several variations may be made to the invention and that the rights associated with the invention are not limited by the details of the preceding description but are defined by the appended claims. In particular, dimensions which are provided are typical and it will clearly be understood that these may vary, as required, to suit the application and according to materials available.



**Claims**

1. A precast concrete slab having oppositely disposed operatively upper and lower faces and side walls coupling the upper and lower faces, the side wall adjacent to the upper face being orthogonal thereto and the side wall adjacent to the lower face on two opposite sides of the slab being somewhat recessed to define a chamfer on forward and trailing edges therefor.
2. A precast concrete slab according to claim 1 which has rectangular upper and lower faces.
3. A precast concrete slab having a plurality of reinforcement bars disposed within the slab at spaced intervals along its length, the bars having extremities which protrude laterally from the slab on opposite sides thereof.
4. A precast concrete slab according to claim 3 in which a selected number of said reinforcement bars extend upwardly above an operatively upper face of the slab to define anchors for securing a concrete topping to be poured onto the precast concrete slab.
5. A precast concrete slab according to claim 4 in which the anchors are defined by a plurality of inverted U-shaped portions.
6. A precast concrete slab having a plurality of reinforcement bars disposed within the slab at spaced intervals along its length, the reinforcement bars having extremities which protrude laterally from the slab on opposite sides thereof,  
a selected number of said reinforcement bars extending upwardly above an operatively upper face of the slab to define anchors for securing a concrete topping to be poured onto the precast concrete slab,  
the precast concrete slab having an operatively lower face disposed opposite said upper face and side walls coupling the upper and lower faces, the side wall adjacent to the upper face being orthogonal thereto and the side wall adjacent to the lower face on two opposite sides of the slab being somewhat recessed to define a chamfer on forward and trailing edges therefor.
7. A precast concrete slab according to claim 6 in which the anchors are defined by a plurality

of inverted U-shaped portions.

8. A system for building a bridge superstructure, the system having a plurality of support beams extending longitudinally along the length of the bridge, and erected at predetermined spaced locations across the width of the bridge to define a separation, the support beams each having a plurality of beam anchors secured to the support beams;
- screed adjustors provided in pairs for disposing on opposed lateral edges of the support beams;
- precast concrete slabs having a width for spanning said separation between the support beams, the slabs having a plurality of slab reinforcement bars disposed within the slabs at spaced intervals along the lengths of the slabs, the slab reinforcement bars having free extremities which protrude from the slabs on opposite lateral sides thereof, and a selected number of said slab reinforcement bars extending upwardly above an operatively upper surface of the slabs to define slab anchors for securing a concrete topping to be poured onto the precast concrete slabs;
- deck reinforcement bars for coupling the precast concrete slabs to the beam anchors;
- and ties for securing the deck reinforcement bars to the beam anchors and to free extremities of the slab reinforcement bars.
9. A deck system according to claim 8 having a plurality of precast concrete slabs each having rectangular upper and lower faces.
10. A deck system according to claim 8 having a plurality of precast concrete slabs each having parallel lateral edges, and forward and trailing edges for abutting on adjacent precast concrete slabs which are not orthogonal to said lateral edges.
11. A deck for a bridge superstructure having a plurality of support beams extending longitudinally along the length of the bridge, and erected at predetermined spaced locations across the width of the bridge to define a separation, the support beams each having a plurality of beam anchors secured to the support beams and screed adjustors disposed in pairs on opposed lateral edges of the support beams, the deck having;
- a plurality of precast concrete slabs disposed with forward and trailing edges abutting one another along the length of the associated support beams, the precast concrete slabs having a width

for spanning said separation between the support beams, the slabs having a plurality of slab reinforcement bars disposed within the slabs at spaced intervals along the lengths of the slabs, the slab reinforcement bars having free extremities which protrude from the slabs on opposite lateral sides thereof, and a selected number of said slab reinforcement bars extending upwardly above an operatively upper surface of the slabs to define slab anchors for securing a concrete topping formed *in situ* on the precast concrete slabs;

deck reinforcement bars coupling the precast concrete slabs to the beam anchors;

and ties securing the deck reinforcement bars to the beam anchors and to free extremities of the slab reinforcement bars.

12. A deck according to claim 11 in which the precast concrete slabs have parallel lateral edges and the forward and trailing edges at the ends of a span are not orthogonal to said lateral edges;

13. A deck according to claim 11 having additional reinforcement bars disposed in said concrete topping.

14. A deck according to claim 11 having a waterproof sheeting disposed above the concrete topping.

15. A deck according to claim 11 having asphalt disposed above the concrete topping.

16. A deck according to claim 14 having asphalt disposed above the waterproof sheeting.

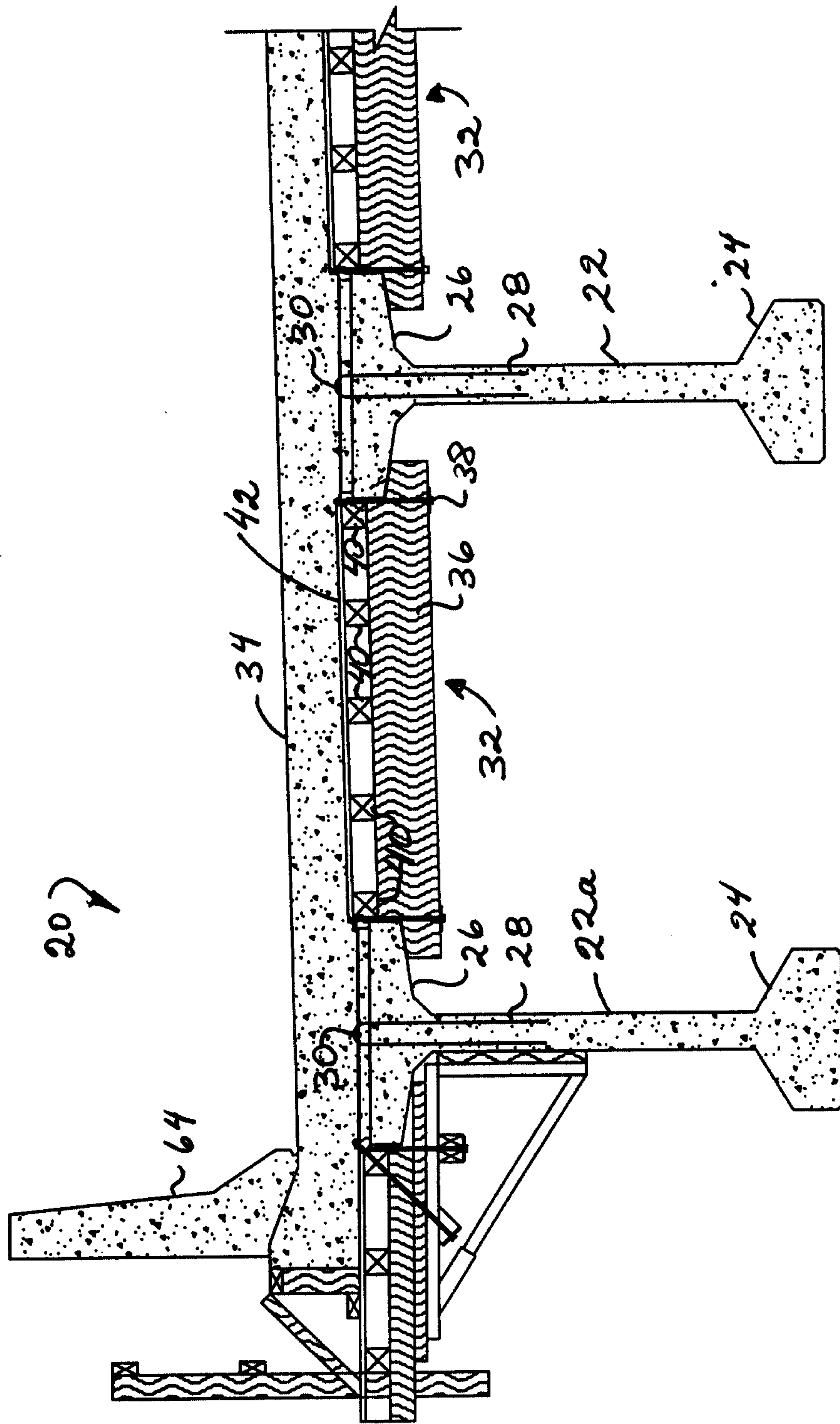

Fig 1  
(Prior Art)

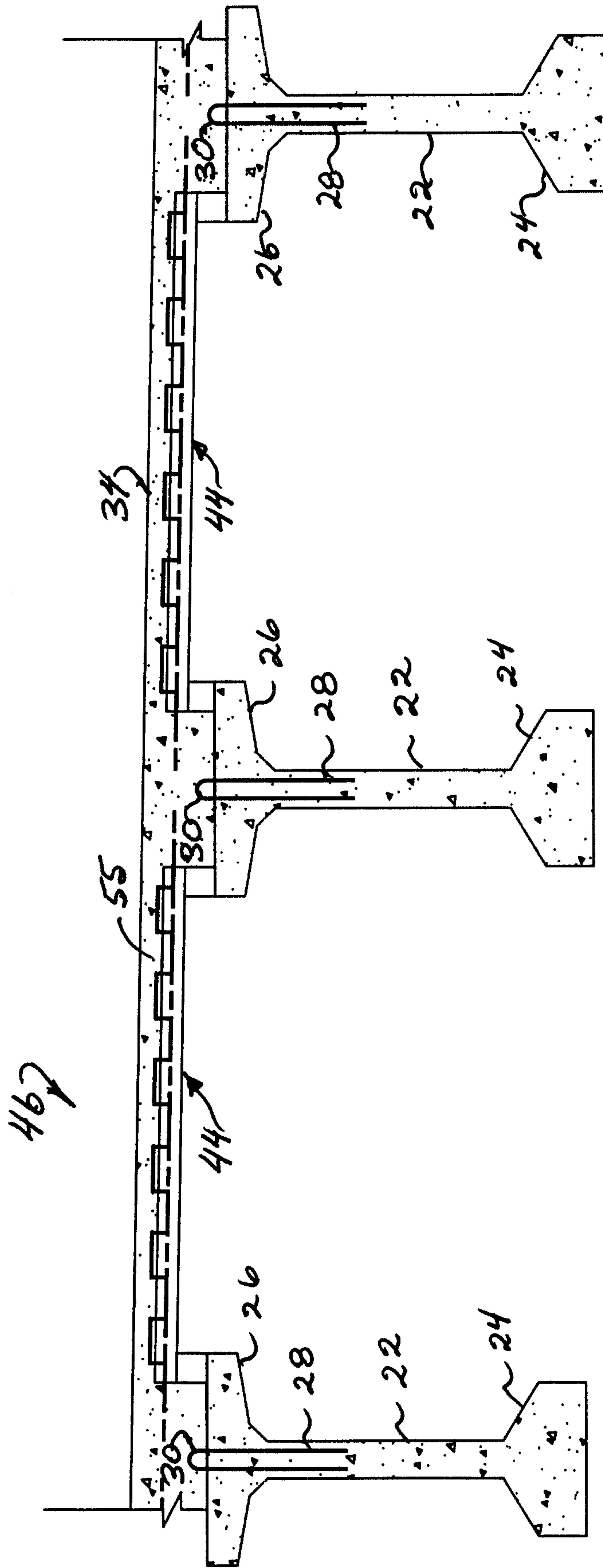

Fig 2

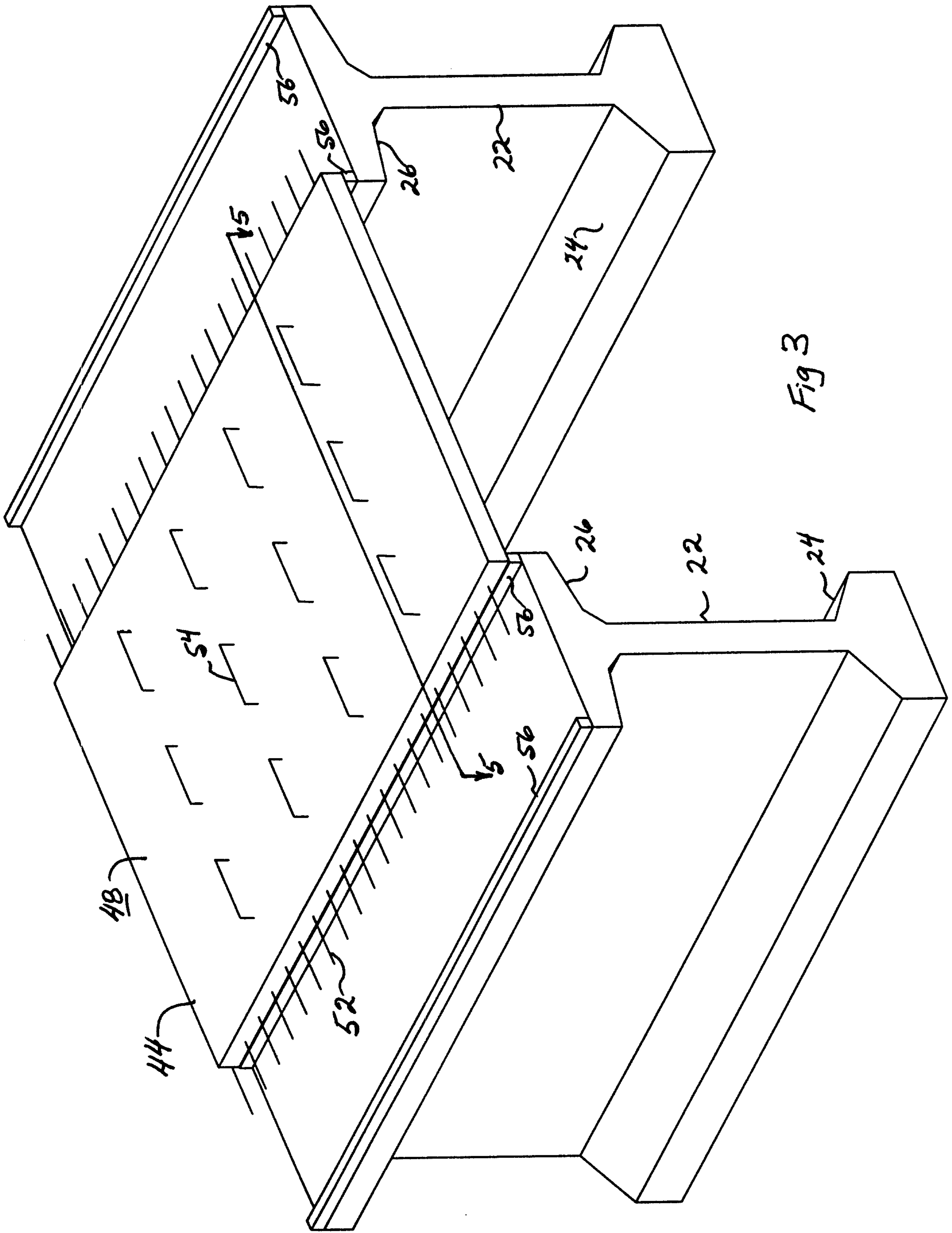

Fig 3

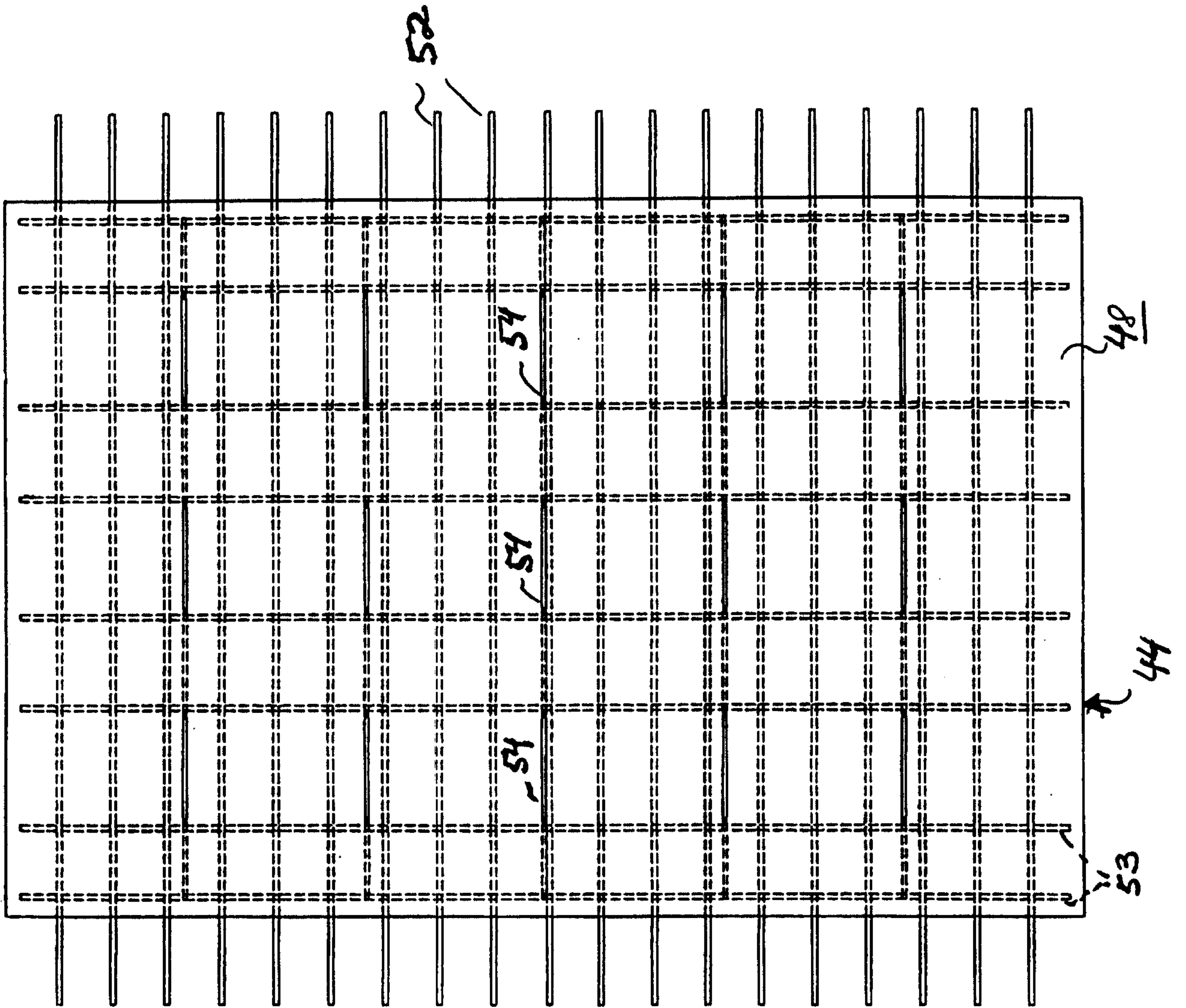
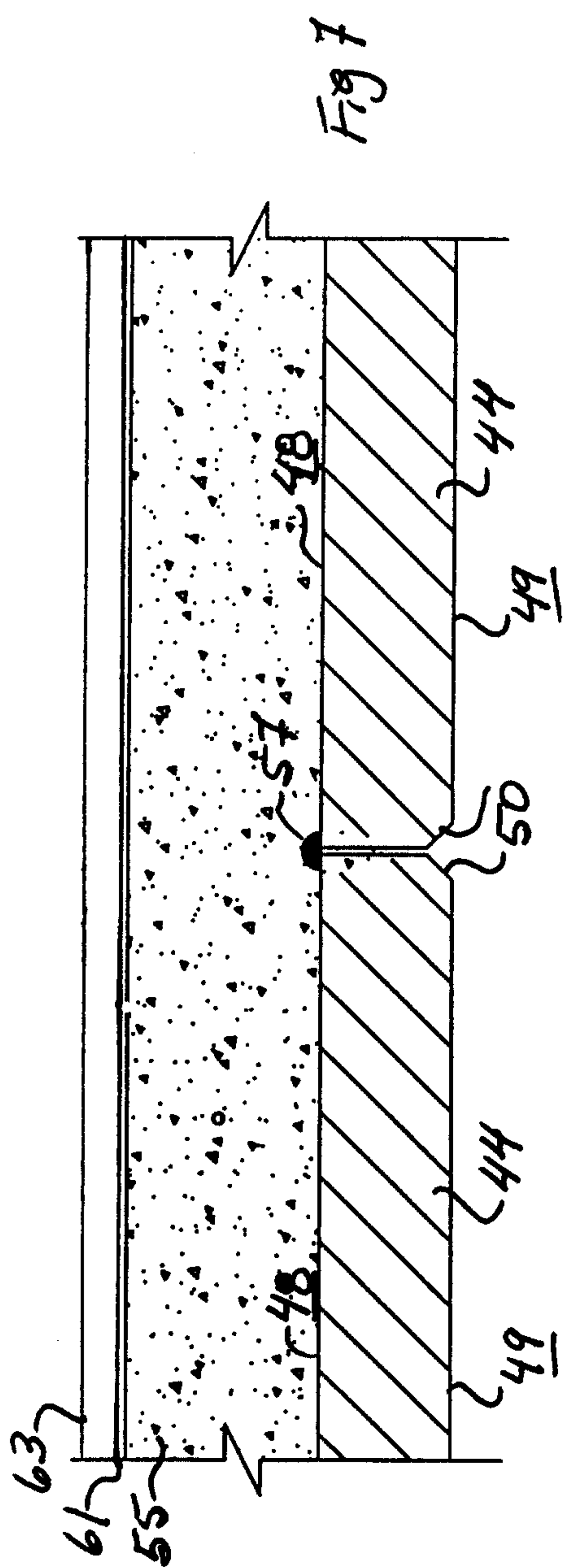
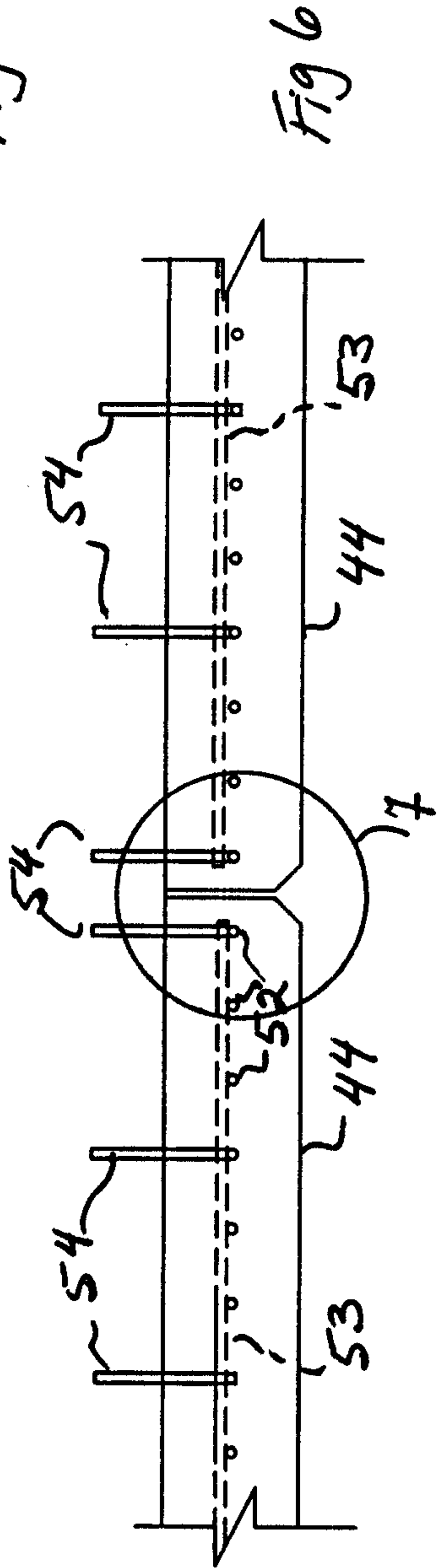
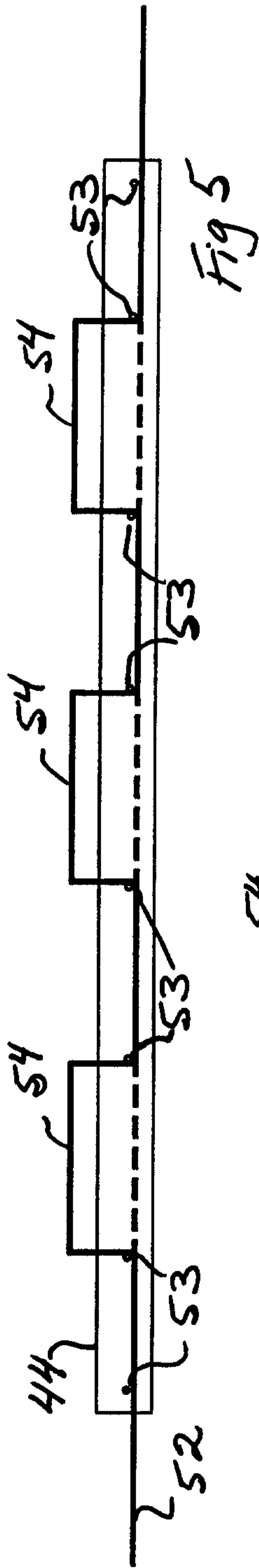

Fig 4





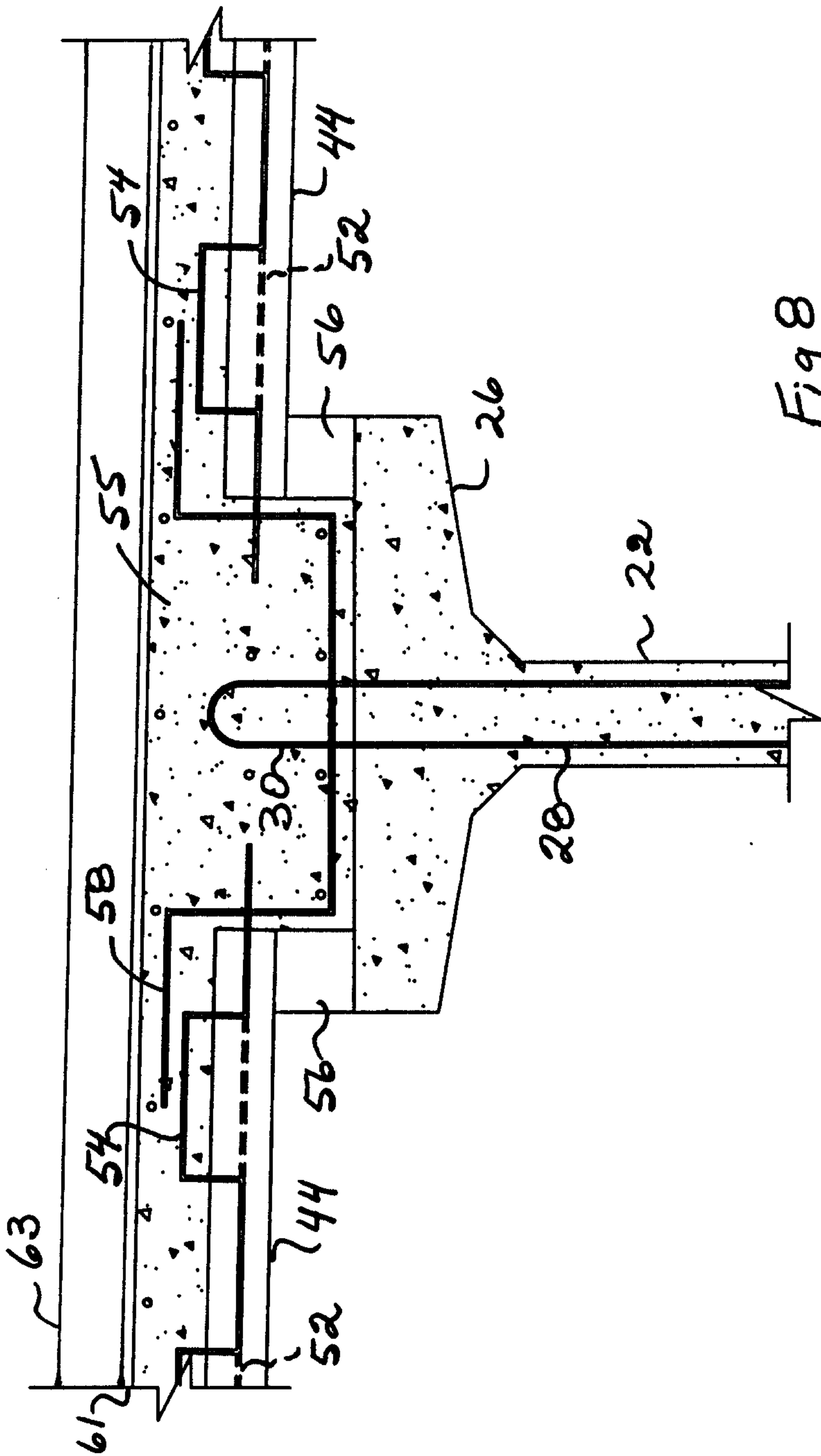

Fig 8

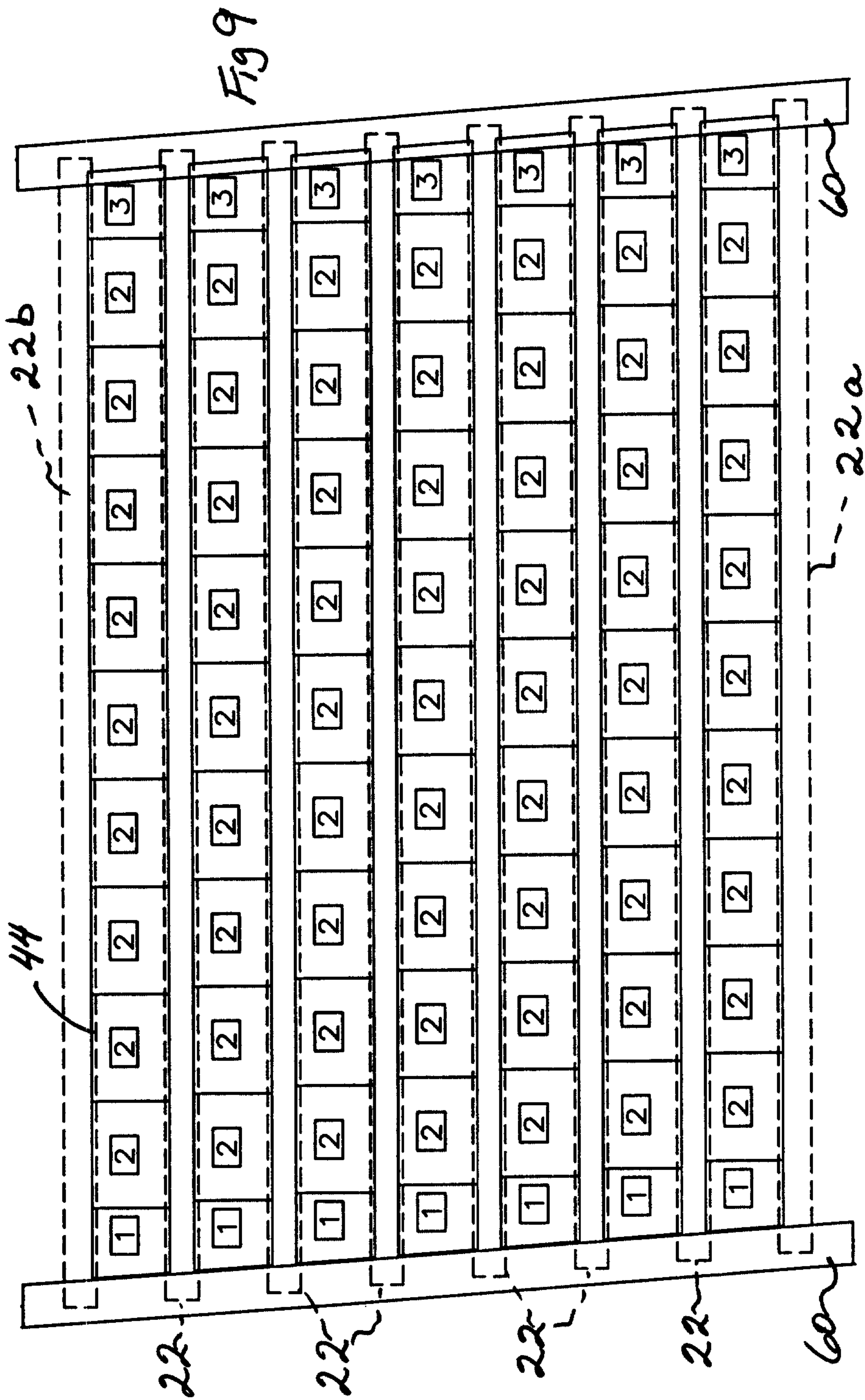

Fig 9

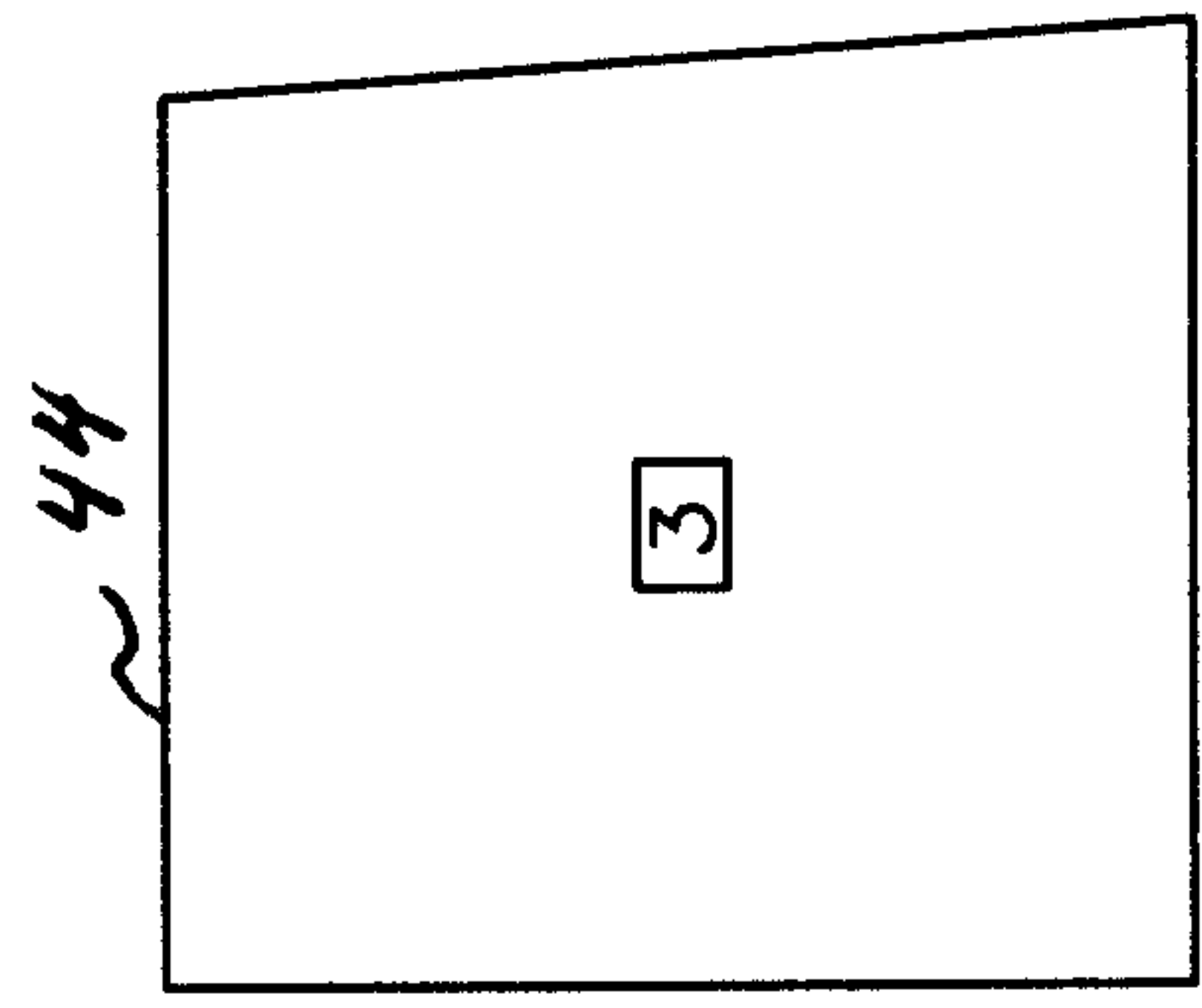

Fig 10

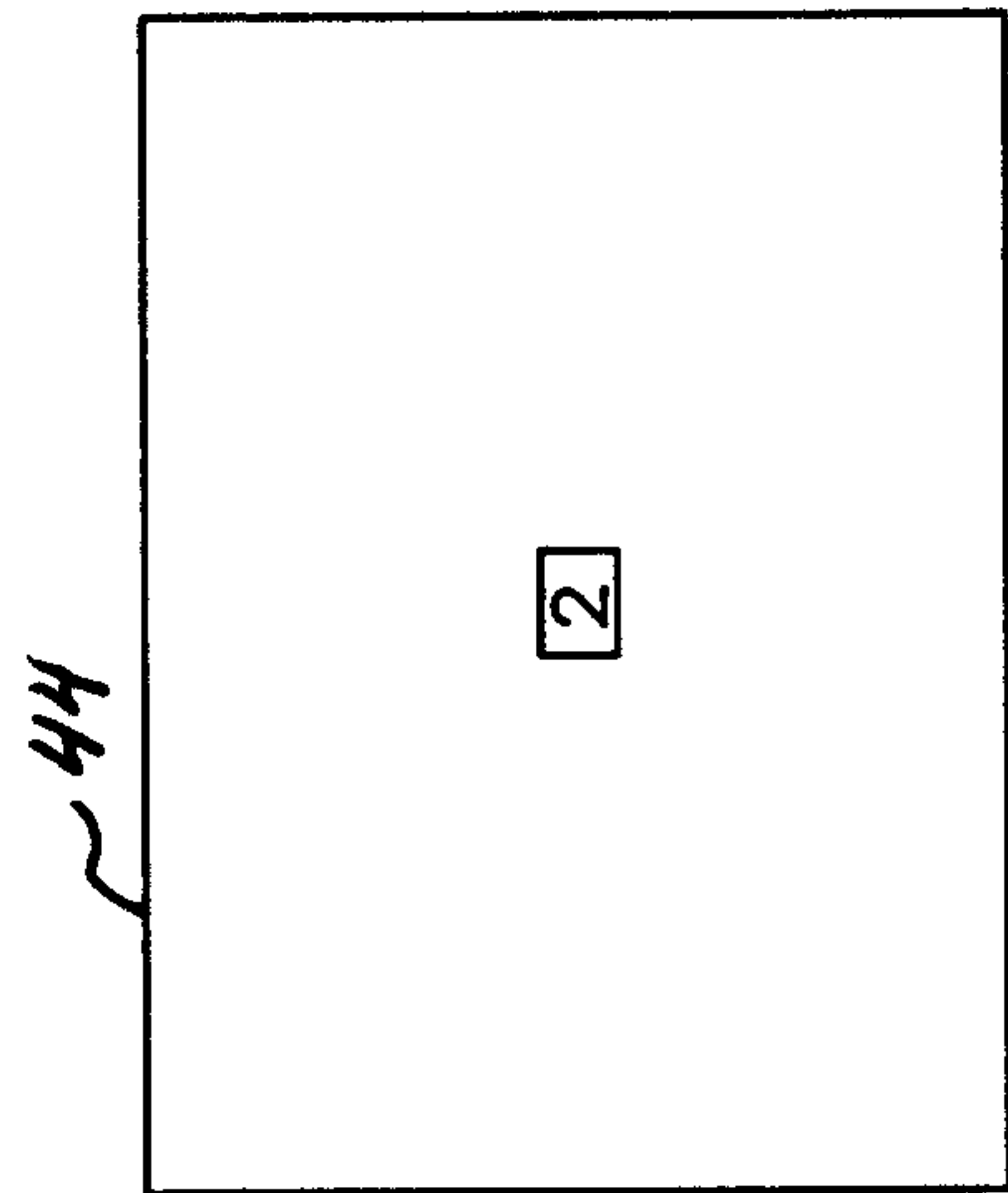

Fig 11

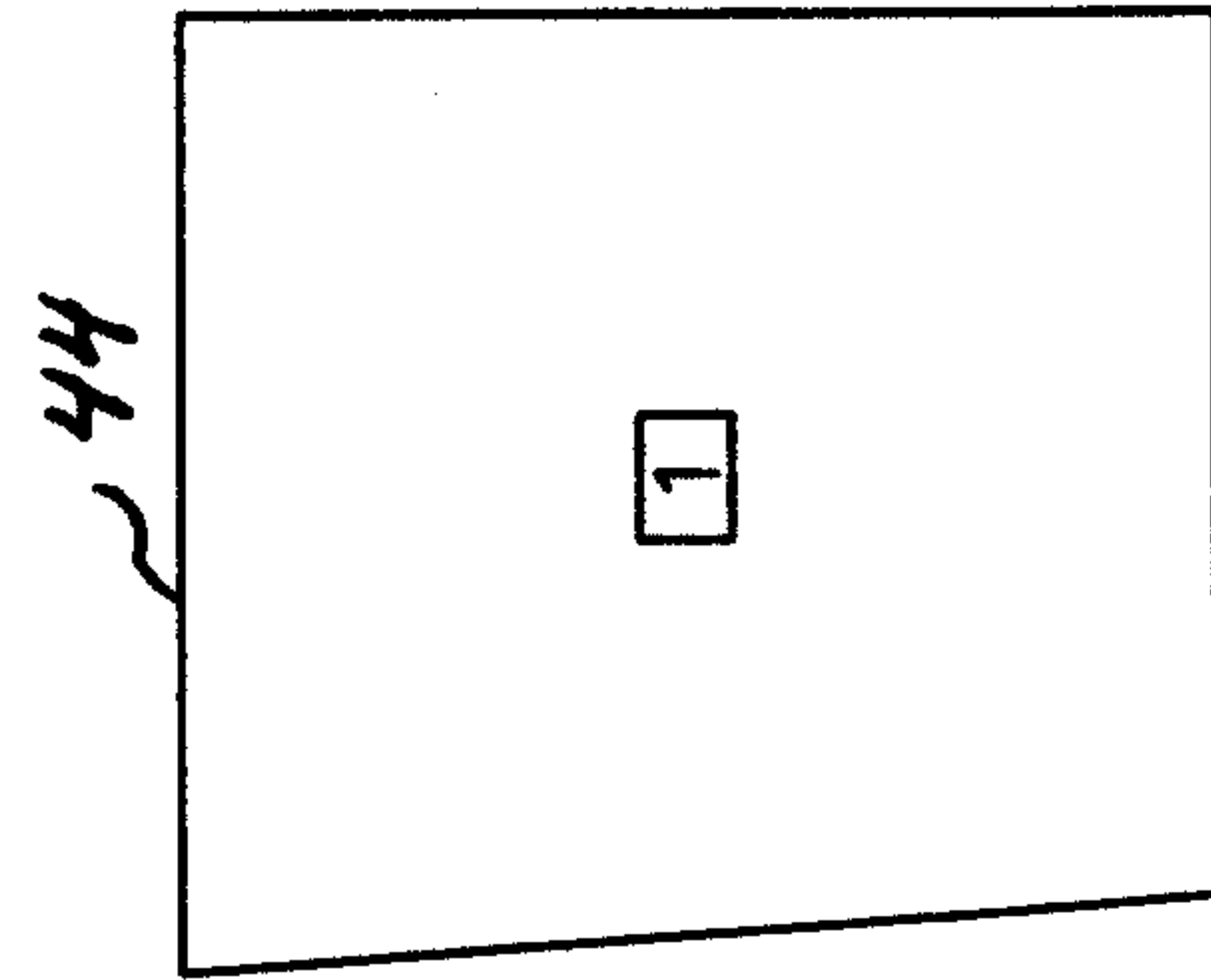

Fig 12

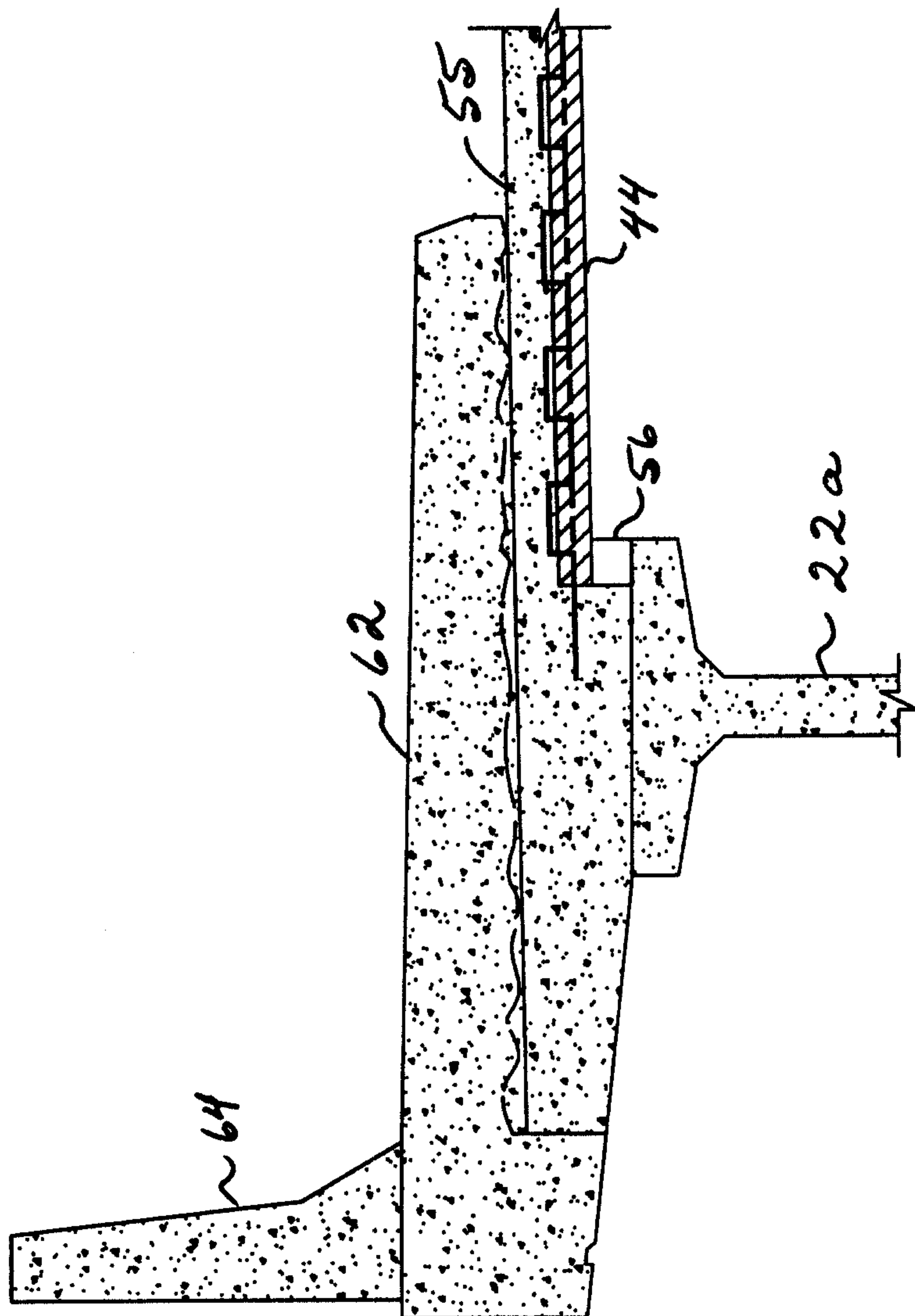

Fig 13

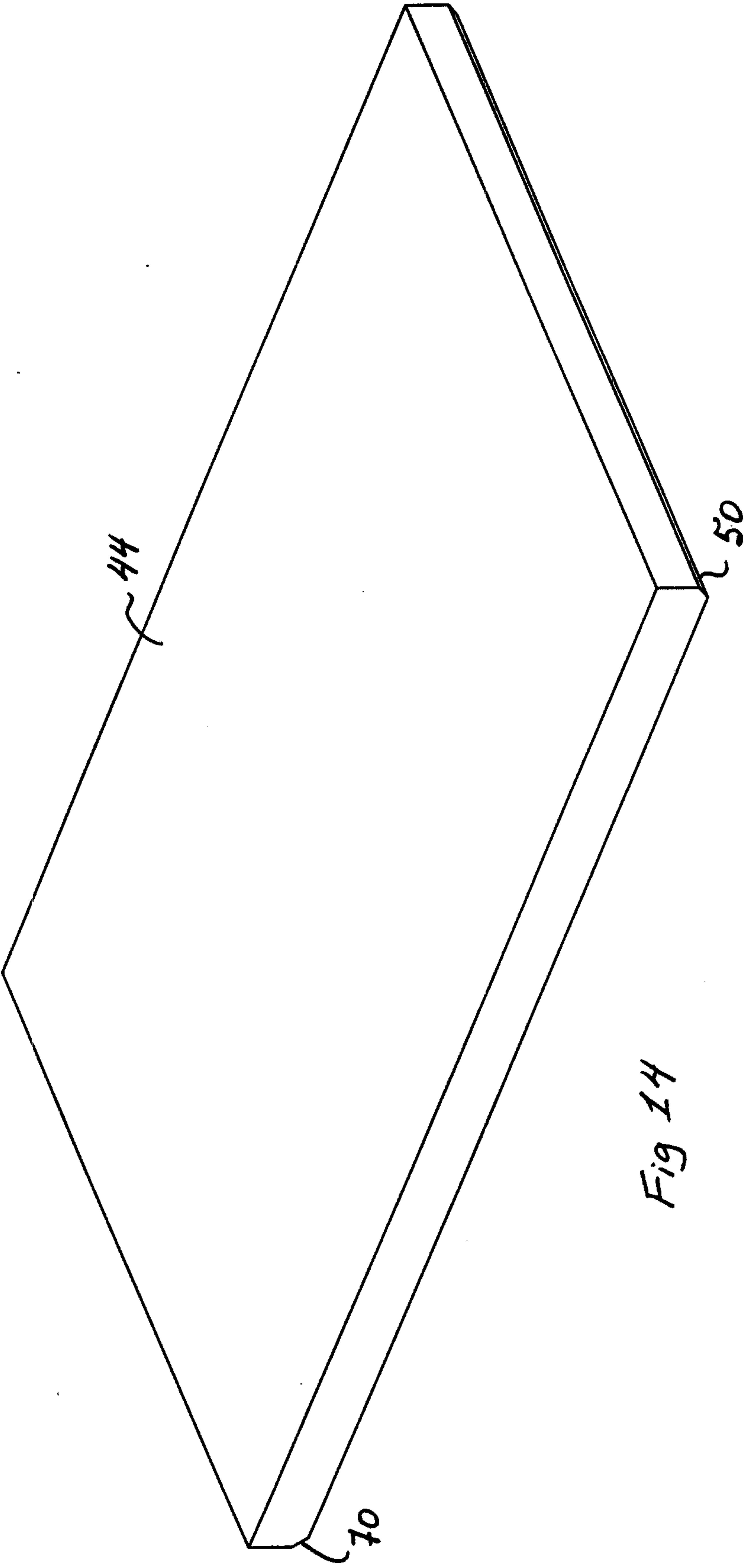

Fig 14

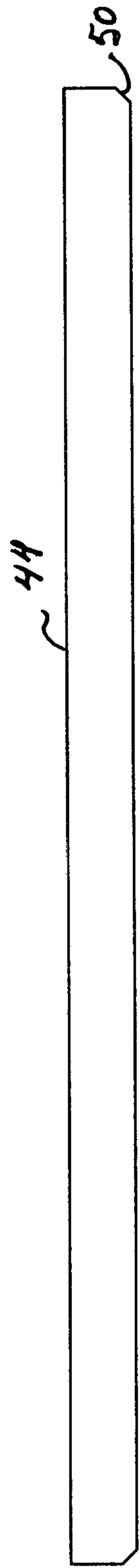

Fig 15

44

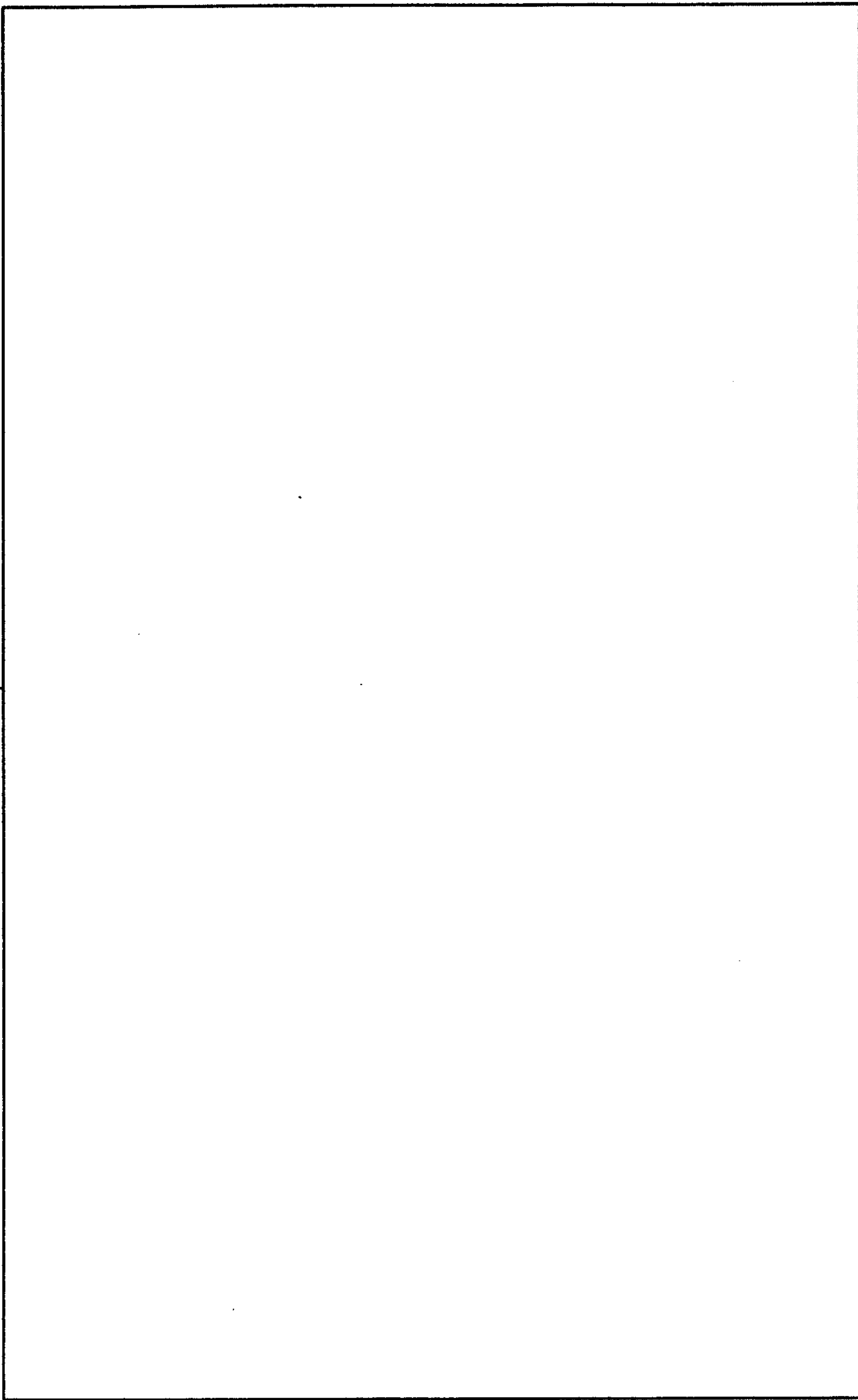

Fig 16

44

50



Fig 17

