



(12) **EUROPEAN PATENT APPLICATION**

(43) Date of publication:  
**29.12.1997 Bulletin 1997/52**

(51) Int Cl.6: **B41J 29/02**

(21) Application number: **97304185.8**

(22) Date of filing: **16.06.1997**

(84) Designated Contracting States:  
**AT BE CH DE DK ES FI FR GB GR IE IT LI LU MC  
NL PT SE**

• **Bowling, Bruce A.**  
**Beavercreek, Ohio 45432-2613 (US)**

(30) Priority: **18.06.1996 US 665563**

(74) Representative: **Freed, Arthur Woolf et al**  
**Reginald W. Barker & Co.,**  
**Chancery House,**  
**53-64, Chancery Lane**  
**London, WC2A 1QU (GB)**

(71) Applicant: **Scitex Digital Printing, Inc.**  
**Dayton, Ohio 45420-4099 (US)**

(72) Inventors:  
• **Simon, Robert J.**  
**Bellbrook, Ohio 45305 (US)**

(54) **Continuous ink jet print head**

(57) A larger print width print head apparatus for an ink jet printer comprises a droplet generating means and a means for providing fluid to the droplet generating means. The apparatus further comprises a means for charging and collecting drops from the droplet generating means and a means for providing data signals to the

means for charging and collecting drops. The apparatus further comprises a two-member housing means containing the print head apparatus with removable ink jet components so that failed ink jet components can be returned to a central refurbishment center without sending all the associated electronics.

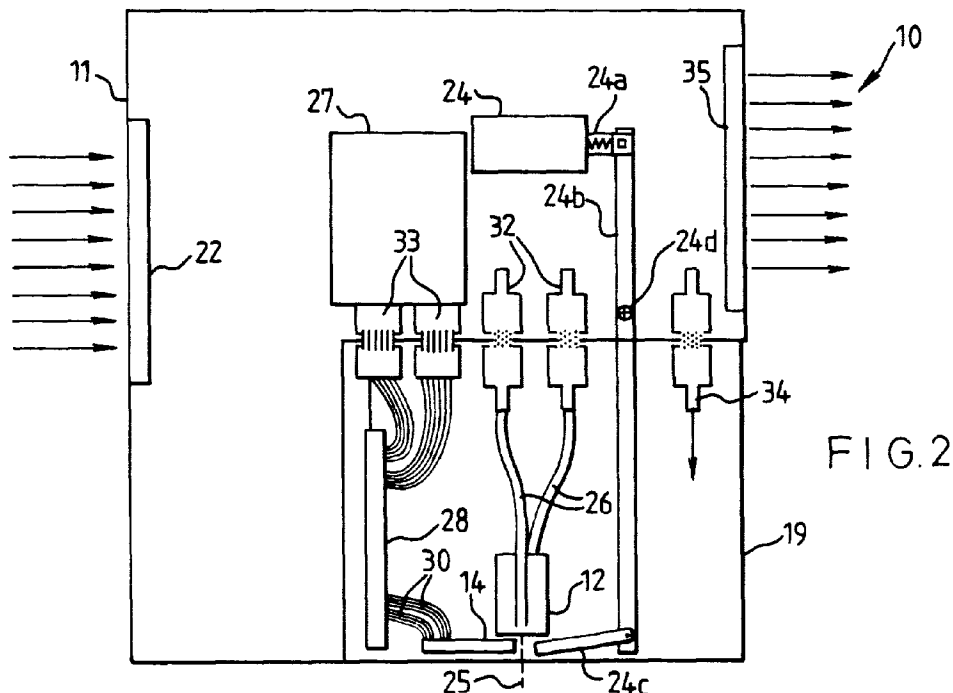

FIG. 2

## Description

### Technical Field

The present invention relates to continuous binary array ink jet technology and, more particularly, to improved ink jet printhead component design and operation.

### Background Art

Continuous binary array ink jet technology was first successfully commercialized by Mead Corporation of Dayton, Ohio, in the midnineteen-seventies. In this technology, a print head defines one or more rows of orifices which receive an electrically conductive recording fluid, such as for instance a water base ink, from a pressurized fluid supply, manifold and ejects the fluid in rows of parallel streams. Printers using such print heads accomplish graphic reproduction by selectively charging and deflecting the drops in each of the streams and depositing at least some of the drops on a print receiving medium, while others of the drops strike a drop catcher device.

In the prior art, it is known to have separate assemblies for each component of the ink jet print head. For example, the orifice plate and the charge plate, and electronic driving components are separate assemblies. Other systems interconnect the electronic source of the data to be printed to the print head components which charge and deflect the jets to accomplish the printing task. The print head components are of such precision and sensitivity that occasionally evanescent dirt, an electrical transient of some type, or wear causes a print head to fail. When that happens, the print head must be returned to a central site for refurbishment. When a print head needs to be replaced or repaired, there are several critical tolerances within the print head assembly that need to be maintained. For instance, if a component of one assembly is replaced, the replacement component is required to be realigned with the various other components in the assembly. The realignment process requires specific, precise realignment tools. The process, therefore, is time consuming and costly, and must be done in a controlled environment. This is why print heads are sent to a central facility for overhaul.

In the design of a print head, concerted efforts are made to integrate the various components and assemblies into a rugged structure which is capable of maintaining alignment. In some designs, various components, such as charge plates and drop stream generators could be disassembled and replaced in the field. However, that approach required alignment of some components in the field as a part of the component replacement. At the same time, market demands for improved print quality led to development of print heads containing more jets per linear inch. As the print quality of binary array continuous ink jet improved, the align-

ment tolerances became even tougher to maintain, so that replacement of print head component parts in the field was no longer practical.

The commercial state of the art in continuous binary array ink jet technology allows printing at 240 dots per inch (dpi). This is done with a linear array of jets, in which the spatial density of jets is the same as the print resolution. See, for example, U.S. Patent 4,636,808 which is totally incorporated herein by reference. With the ever increasing demand for improved image quality, there is a need to further increase the print resolution. Existing systems at 240 dpi have the inherent capability to be scaled to the higher print resolutions needed. However, practical problems have hindered the development of such systems. A 240 dpi continuous binary array system with flat face charging scheme, as described in the '808 patent, has 240 electrical charging leads per inch on the charge plate. To make a practical printer, each of these leads must be connected to external circuitry which supplies the imaging data. Making electrical connections to these leads even at 240 dpi is a major hindrance to further improvement of resolution.

In the prior art, conducting traces, from the face of the charge plate "fan out" across the top of the charge plate, to an interconnection point where the leads are much more widely spaced than they are at the active surface of the charge plate. This is necessary because the current state of the art in connection technology, allows only about one hundred connections per linear inch. By using the fanout technique, connections to 240 charge leads per inch is achieved with the commercially feasible interconnection density of 100 connections per inch. The cost of this is print head space, because at the interconnection point, there are 2.4 inches of connection space for each inch of active print width. It is clear that this requires a much larger charge plate than is otherwise required for the '808 technology. Typically, fanout causes the charge plate to be two or three times deeper than would be required by other print head constraints. This, in turn, causes the print head to be larger than the desirable size.

Another aspect of the interconnection problem relates to the number of connections which need to be made between the print head and the data source. For example, the prior art print head uses 1024 print jets at a resolution of 240 jets per inch. Although the print width is only 4.267 inches, 1024 connections to the data system are required. To accommodate print heads with a large number of jets, it is common practice to send data to a print head in a series of 1's and 0's, serial form, and to convert the serial data back to "parallel" data in the print head. This raises the rate at which data must be transferred over the "serial" connection, but dramatically reduces the number of connections. Use of this technique means that there are some electronic components which also reside in close proximity to the charge plate. In the example just described of the "four inch" print head, common practice is to use an electronic chip

which contains drivers for 64 jets, and is driven through 8 input connections. The four inch print head requires 16 such chips mounted in close proximity to the actual charge electrodes in the print head.

There are additional electronic components in prior art print heads. For example, manufacturing differences between components mean that different print heads produce best quality print output at slightly different voltages, ink pressures, operating frequencies, etc. These "personality" differences are accommodated by putting a computer in the print head to communicate the specific needs of the print head to the fluid supply station which supplies power and fluids to the print head. The computer is also useful to record any problems which may have been detected in the print head, the length of its use, the exact phase required for the charging voltage in relation to the drop generation sequence for each jet, etc.

The entire electronic package must be mounted in close proximity to the operating ink jets, and in prior art, is designed as part of the structure of the print head. This has led to a problem because the ink jet components have a much shorter useful life in a print head than the electronic components. When a print head is sent back to the refurbishment center because of a problem with the ink jet components, the electronic system which supports the print head and is part of it is sent back as well, even though it is operating properly. This means that when hundreds of these print heads are in service, and other hundreds are in transit to and from the refurbishment center, there is a huge waste in the "float" of good electronic components.

It is seen then that there is a need for a print head design in which the ink jet components can be made into a field replaceable assembly which can be quickly and easily replaced without requiring alignment. It is also seen that there is a need for wider print heads. It is further seen that there is a need for a print head structure in which the ink jet components can be replaced in the field without affecting the print head control electronics.

#### Summary of the Invention

These needs are met by the assembly means and method according to the present invention, wherein a two-member print head apparatus is disclosed.

In accordance with one aspect of the present invention, a larger print width print head apparatus for an ink jet printer comprises a droplet generating means and a means for providing fluid to the droplet generating means. The apparatus further comprises a means for charging and collecting drops from the droplet generating means and a means for providing data signals to the means for charging and collecting drops. The apparatus further comprises a two-member housing means containing the print head apparatus with removable ink jet components so that failed ink jet components can be returned to a central refurbishment center without sending all the associated electronics.

Accordingly, it is an object of the present invention to provide a continuous ink jet print head with separate electronics. It is a further object of the present invention to provide a continuous ink jet print head with refurbishable components. It is an advantage of the present invention that parts which are sent back from the field for refurbishment are field separable from the print head electronic components.

Other objects and advantages of the invention will be apparent from the following description, the accompanying drawings and the appended claims.

#### Brief Description of the Drawings

Fig. 1 illustrates a front view of a two element print head assembly in accordance with the present invention; and

Fig. 2 illustrates a side view of the two element print head assembly of Fig. 1.

#### Detailed Description of the Preferred Embodiments

The present invention provides for a nine inch print head assembly which provides a minimum package size and minimizes operator interventions. In operation, the nine inch print head is similar to that of the earlier generation print head described in U.S. Patent No. 5,455,611 which is totally incorporated herein by reference. Ink jet printers are typically comprised of several components, including a fluid system, data system, and print head. The fluid system provides electrical control of the components required to control drop formation and maintain fluid quality. The print head, which accepts fluids from the fluid system, generates drops and returns unused drops to the fluid system. The print head selectively controls drop charging to allow imaging on a print medium, utilizing information prepared by the data system. The data system accepts data in standard formats, such as ASCII, EBCDIC, etc., along with print start and delay signals. The information is transferred to the print head for imaging.

In the drawings, for purposes of illustration only, components within a preferred embodiment of a print head have been expanded from what is typical for a continuous ink jet printer print head to include all the control sensors required for maintaining drop quality. The drawings will be described with reference to a preferred embodiment of the present invention, wherein the preferred embodiment is a nine inch printer which incorporates 2176 printing jets, but are not to be considered as limiting the invention.

Referring now to Fig. 1, a two element print head assembly 10 is shown in a ready to use state attached to a print head interface controller (PIC) box 11. The separate housing 19 is the refurbishable print head module (RPM). The RPM houses a droplet generator means 12 which has been previously coupled to a droplet charging and collecting means 14. Filtered fluids are provided to

the droplet generator means 12 and removed from the droplet charging and collecting means 14 via a fluid control manifold 16 located in the PIC box. The connections between the PIC box and the RPM are established by fluidic and electrical connecting means which are mated by latching means (not shown) when the two components are attached into an operational state. The fluid control manifold 16 in the PIC box contains an ink temperature sensor 16a, an ambient temperature sensor 16b, and an airflow path in the direction of arrow 16d. The airflow path 16d is controlled by a solenoid valve 16e. The solenoid valve 16e allows air to flow into and through the droplet generator means 12 during the print head shutdown sequence to accelerate removal and drying of ink. To prevent drying of ink in the main filter 17a during shutdown, a second filter 17b located in the RPM 19 is provided for the vent. This venting capability is particularly advantageous for overnight storage and transportation. Ink supplied from the fluid manifold 16 in the PIC box is filtered by filter means 17a prior to being supplied to the drop generator means 12.

The manifold assembly 16 also houses a pressure measuring means 16f for precisely controlling the pressure at which drops are generated, as well as an outlet valve 16g. The outlet valve 16g is activated to provide a high flow rate through the droplet generator means 12 during startup for dissolving ink and wetting the orifice plate attached to the droplet generator. When the outlet valve 16g is closed, pressure builds up sufficient for droplet formation. During each of these operations the pressure in the droplet generator means 12 is monitored for servo control via the pressure measuring means 16f. During cross flush conditions, a small positive pressure is maintained, typically 0.5 to 1.0 psig, to prevent air ingestion into the droplet generator means 12 where air can become trapped. The trapped air would then prevent uniform drop generation. Continuing with Fig. 1, ambient and ink temperature sensors, 16b and 16a respectively, can be utilized by an external controller to provide ink at a fixed temperature relative to the surroundings. This is utilized for condensate cleaning of the drop charging and collecting means 14 during startup conditions. This could also be utilized during normal run operations. When the RPM 19 is connected to the PIC box 11, a plurality of electrical and fluidic connections are maintained so that the RPM is in an operable state. In the event of a failure of the ink jet components, the RPM 19 can be easily disconnected from the PIC box 11, so that the print head can be returned to the refurbishment center. A replacement print head can be immediately attached to the PIC box 11 using latching means not shown in the diagram, and work can be resumed. The size of the combination PIC box and print head is smaller than the prior art print heads, two of which would be needed to cover a comparable print width. In part, this is enabled by improved interconnection technology in the drop charging and collecting means 14.

Referring now to Fig. 2 and continuing with Fig. 1, an eyelid 24c is used in the closed position to divert ink into the drop collection means 14 for removal via a flow path 20 during the start up and shut down conditions. In the normal operating (printing) condition, the eyelid 24c is opened to allow the selected drops 25 to strike a print medium which is not shown in Fig. 2. The eyelid 24c is activated (opened) using electromechanical means 24 in the PIC box which is connected to a link 24b, and which pivots at pivot point 24d. A bias means 24a is used to close the eyelid 24c against the drop charging and collecting means 14 in the default state. Placement of the activation components (in the PIC box) away from the ink usage area prevents ink from drying on the pivots, etc. where they could cause sticking or binding of the eyelid motion.

Both print means elements, the PIC box and the RPM are fully enclosed by housing means 11 and 19 except for small gaps in the region of the moving eyelid 24c. The small gaps allow positive air pressure to be maintained within the assembly 10. Positive air is supplied to the PIC box by a fan (not shown). The positive air flows into the PIC box through opening 22, past the PIC box electronics 27, and out through another opening in the PIC box 35. Positive air in the RPM is provided via an air pump in the fluid system (not shown) through two ports 34 which also serve as alignment features for the PIC box and RPM. In the prior art, the same clean air was used for cooling and positive air pressure in the print head. However, experience showed that the cooling air could not be maintained clean enough for use near the ink jets 25. Cooling of the RPM electronics is accomplished via a flow of ink which is split from the drop generator path and returned via a path (not shown) beyond the outlet valve used for starting jets.

Referring again to Fig. 2, the charge electrode drivers reside on an electronic circuit board 28 in the RPM 19 and connect to the drop charging and collecting means 14. The PIC box electronics board 27 connects to fluid system, the data system, and the print head. The board 27 takes print data from the data system, combines it with timing data from the fluid system, and converts it to a format suitable for high voltage drivers located on the electronic board 28 in the RPM 19. Also residing on the electronic board 28 is the electronics which contains the personality module for the specific RPM. The interface from the data system to the PIC box 11 is preferably accomplished through a fiber optic cable means driven by a fiber optic transmitter (not shown) in the data system. The electronic board 28 in the RPM is connected to the drop charging and collecting means 14 via connecting means 30.

In ink jet printers, the charge and therefore the deflection of a drop depends in the voltage on the charge plate just prior to the break off of the drops. A drop will only be charged for catch if the charge voltage is high during the very short interval just prior to break off. Conversely, a drop will be left uncharged for print only if the

charge voltage is near zero during this time interval. To ensure proper selection of the print drops, it is necessary to maintain proper phase between the print pulses and the break off of drops. To aid the operator in selecting the optimum phase, a microprocessor in the PIC box electronics 27 can generate a diagnostic plot of the stimulation break off phase for each array of jets. From this plot, the operator can readily select the desired operating phase. This plot also provides a check on stimulation uniformity which may indicate a degradation in the drop generator 12.

The PIC box electronics 27 includes the microcontroller which does status monitoring, and selftest control, and monitors the personality module in the RPM for specific fluid system parameters. The microcontroller communicates with the fluid system over a bidirectional serial link. The microcontroller is used to provide a serial interface to the fluid system, transfer status and commands to and from the fluid system, and to control analog components in PIC box.

In the preferred embodiment of the present invention, the PIC box and the RPM assembly are controlled by a fluid system utilizing parameters within the personality module within the RPM. The two member print head apparatus accepts data via a fiber optic link from a data system to ultimately control print drop selection.

Although the preferred mode of practicing the invention has been described with reference to an ink jet print head for a continuous ink jet printer, the principle of the present invention can also be applied to a wide variety of ink jet printers.

#### Industrial Applicability and Advantages

The RPM and PIC box apparatus according to the present invention are useful in continuous ink jet printers. The apparatus of the present invention provides for a separable print head and drive electronics assembly so that the ink jet components can be returned for refurbishment without including the support electronics. The RPM of the present invention has the further advantage of being able to store operating (initial and final) parameters, so that the replacement RPM can work with the same PIC box electronics. The combined PIC box and RPM of the present invention is smaller than the prior art print head, and prints a larger swath than two prior art print heads.

Having described the invention in detail and by reference to the preferred embodiment thereof, it will be apparent that other modifications and variations are possible without departing from the scope of the invention defined in the appended claims.

#### **Claims**

1. An ink jet printer comprising:

a data system;  
a two-element print head assembly for accepting data from the data system to control print drop selection; and  
a fluid system controlled by the two-element print head assembly which provides electrical control for drop formation and fluid quality.

2. An ink jet printer as claimed in claim 1 wherein the two-element print head assembly comprises:

a print head interface controller; and  
a refurbishable print head module, including at least one print head, separable from and attachable to the print head interface controller.

3. An ink jet printer as claimed in claim 2 further comprising a print head interface controller connection means for connecting the print head interface controller to the fluid system, the data system and the at least one print head.

4. An ink jet printer as claimed in claim 2 further comprising a refurbishable print head module connection means for connecting the refurbishable print head module to the droplet charging and collecting means.

5. A print element apparatus with associated electronics for use with an ink jet printer, the print element apparatus comprising:

a. droplet generating means;  
b. a means for providing fluid to the droplet generating means;  
c. droplet charging and collecting means for charging and collecting drops from the droplet generating means;  
d. a means for receiving data signals from the associated electronics for controlling the means for charging and collecting drops;  
e. means for storing operating parameters relating to the droplet generating means, and the droplet charging and collecting means, wherein the print element apparatus is field-replaceable.

6. A print element apparatus as claimed in claim 5 further comprising a print head interface controller having control electronics which is easily attachable to the field-replaceable print element.

7. A print element apparatus as claimed in claim 6 wherein the control electronics comprise:

a. a microcontroller;  
b. fiber optic means for receiving data and control signals and providing the signals to an input

buffer;

c. a random access memory for providing data memory;

d. latch and shift register means for latching and shifting data from the random access memory; 5

e. high voltage driver means for receiving data from the latch and shift register means; and

f. a control state machine which communicates with the microcontroller, for handling generation of all control signals for the input buffer, the random access memory, and the latch and shift register means. 10

8. A print element apparatus as claimed in claim 7 further comprising means for controlling print quality by controlling externally supplied ink pressure, ink temperature, and stimulation level in accordance with internally stored parameters, and utilizing previously measured hole size information to control a number of drops printed on a spot for use in color adjustment. 15 20

9. A print element apparatus for an ink jet printer having a droplet generator and a droplet charging and collecting means, the apparatus comprising: 25

a. a means for controlling externally supplied flow of fluid to the droplet generator;

b. a means for controlling externally supplied data signal voltage levels; 30

c. a field-replaceable housing means for containing the print element apparatus.

10. A print element apparatus as claimed in claim 9 wherein the means for controlling flow of fluid to the droplet generator comprises storage means for storing operational parameters within the print element. 35 40

45

50

55

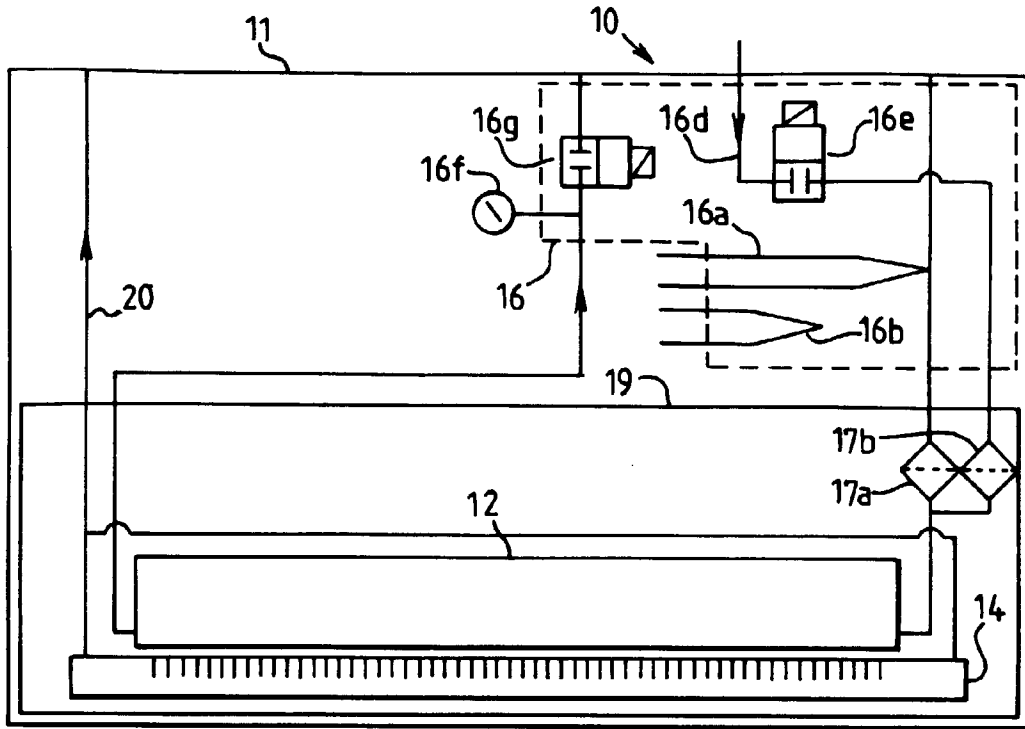

FIG. 1

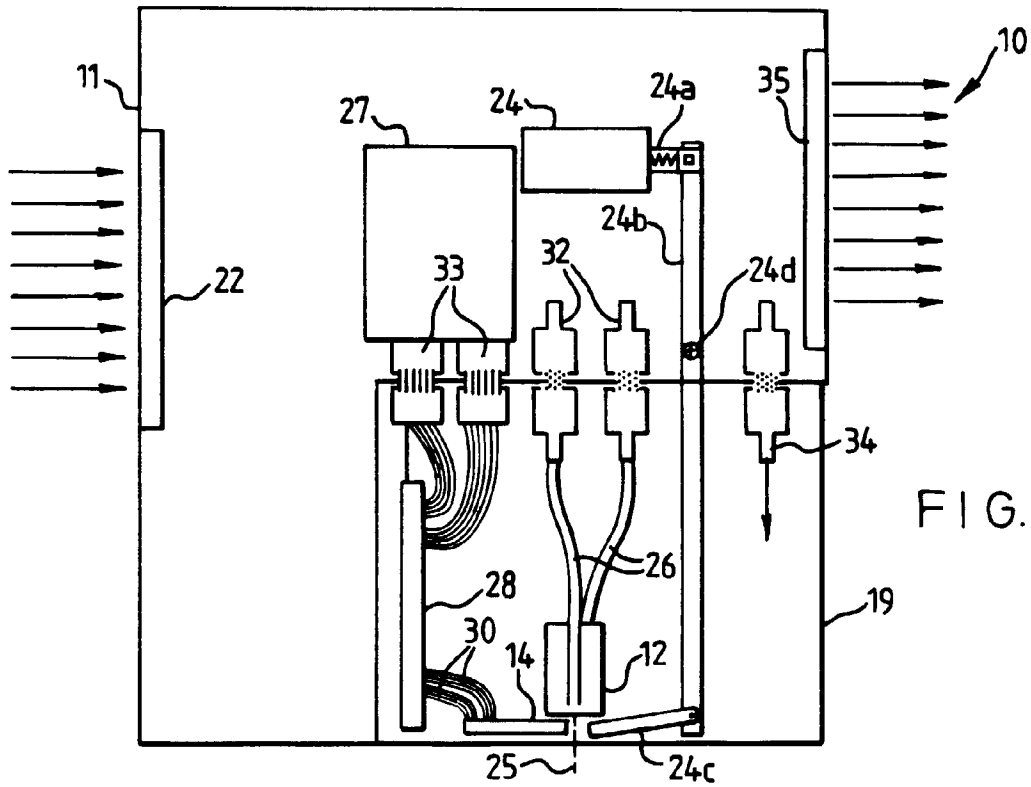

FIG. 2