



US 20070033825A1

(19) **United States**

(12) **Patent Application Publication**

Lo et al.

(10) **Pub. No.: US 2007/0033825 A1**

(43) **Pub. Date: Feb. 15, 2007**

(54) **HOT AIR BLOWER WITH CERAMIC HEATING ELEMENT**

Publication Classification

(75) Inventors: **Hou On Lo**, Kowloon (HK); **Kam Lo**, Kowloon (HK)

(51) **Int. Cl.**
A45D 20/12 (2006.01)
A45D 20/00 (2006.01)
(52) **U.S. Cl.** **34/96; 34/283**

Correspondence Address:
Charles N.J. Ruggiero
Ohlandt, Greeley, Ruggiero & Perle, L.L.P.
10th Floor
One Landmark Square
Stamford, CT 06901-2682 (US)

(57) **ABSTRACT**

There is provided a heating element for an electric air heater including an electric power source, a ceramic base, and a conductive heating film substantially uniformly deposited on at least a portion of a surface of the base and electrically connected to the power source. There is also provided a method for manufacturing the heating element. There is further provided an electric hot air blower including a housing having an air inlet and an air outlet, a fan operatively connected to an electric motor, and an electric heating element located inside the housing that includes a ceramic base and a conductive film substantially uniformly deposited on a surface of the base and electrically connected to a power source. The electric heating element is located along an air flow path of the blower for heating air flow.

(73) Assignee: **Beauty-Gear International Limited**

(21) Appl. No.: **11/371,753**

(22) Filed: **Mar. 9, 2006**

(30) **Foreign Application Priority Data**

Apr. 18, 2005 (CN) 200520015978

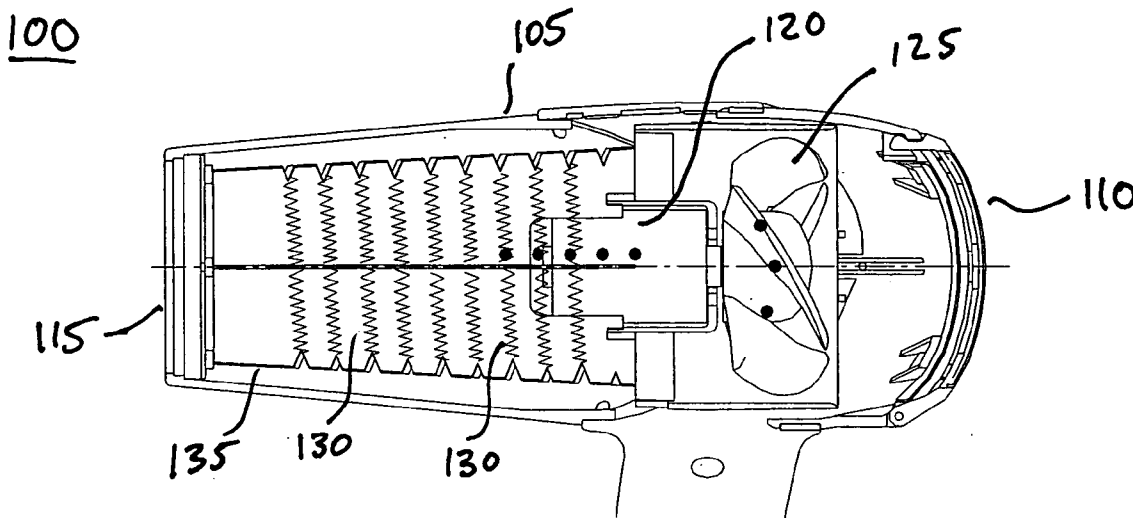

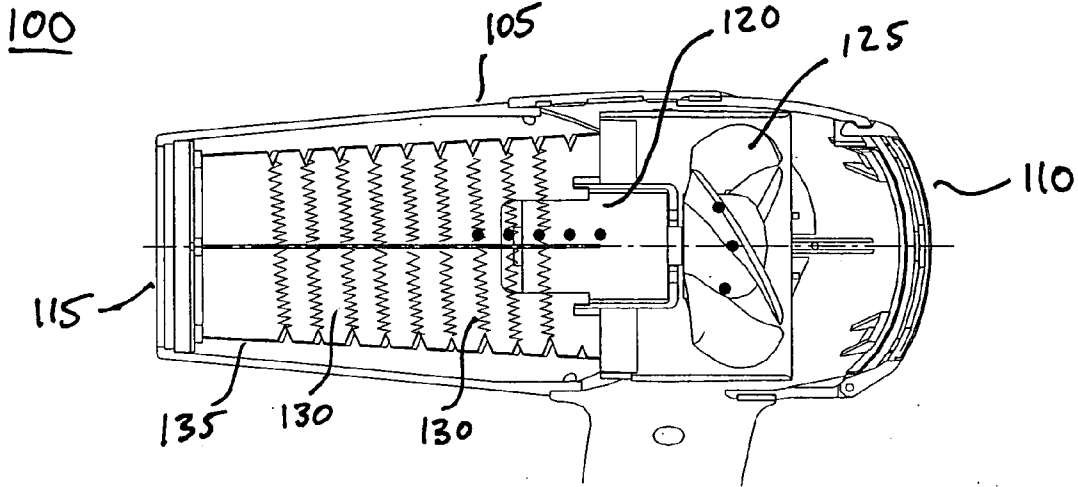

FIG. 1

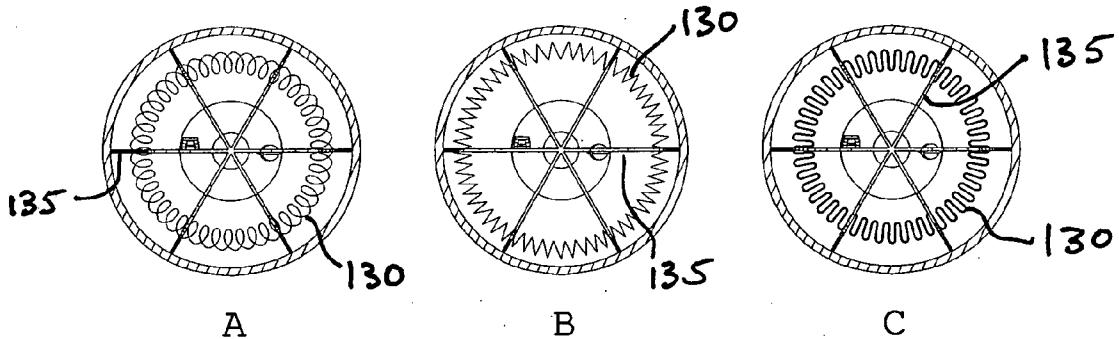

FIG. 2

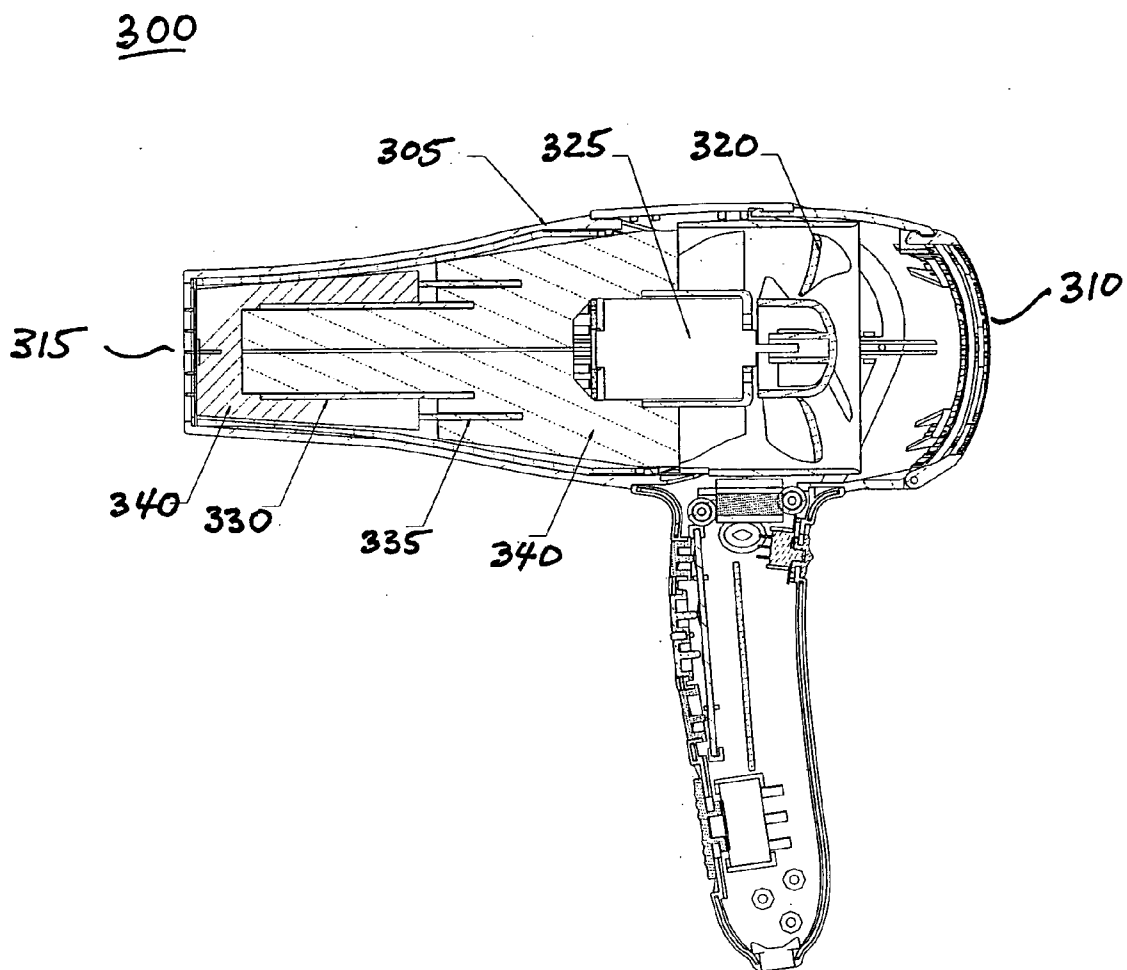

FIG. 3

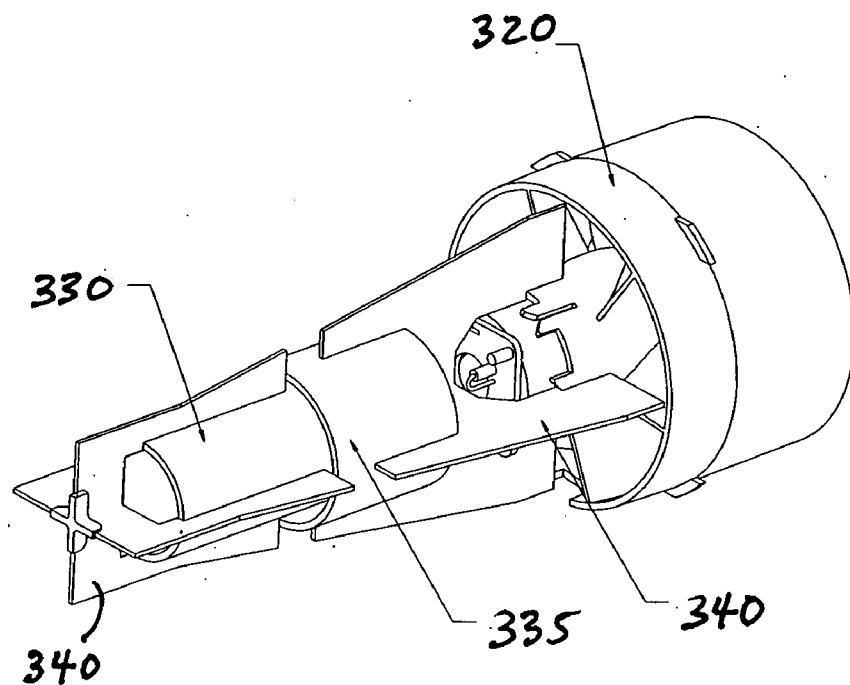

FIG. 4

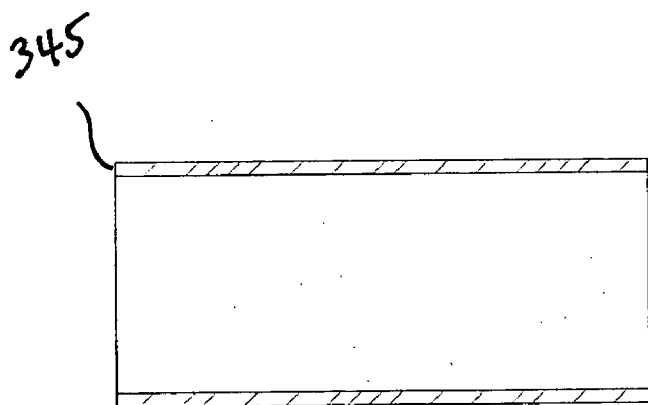

FIG. 5A

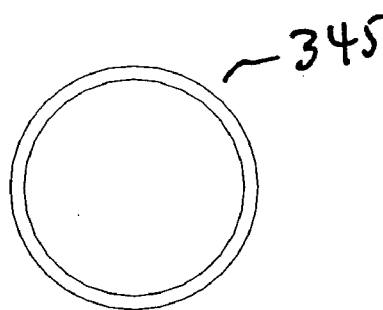

FIG. 5B

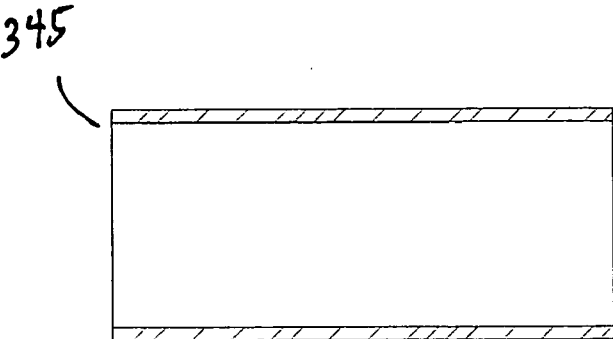

FIG. 6A

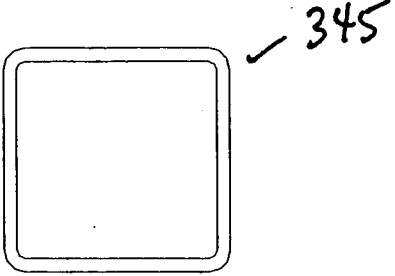

FIG. 6B

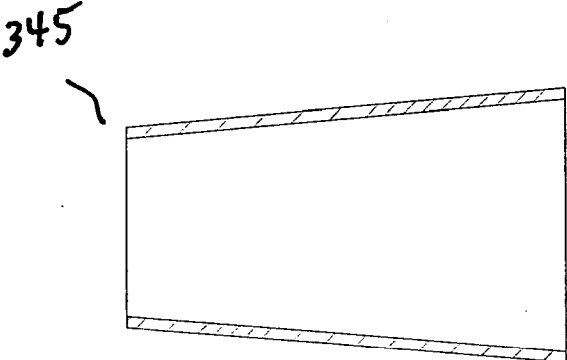

FIG. 7A

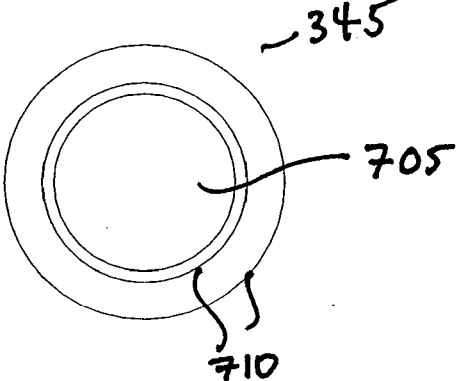

FIG. 7B

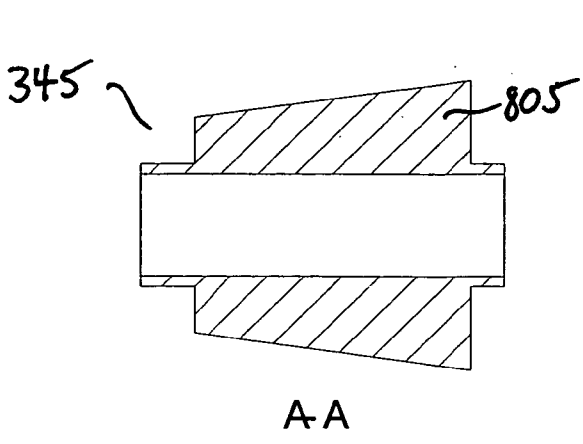

FIG. 8A

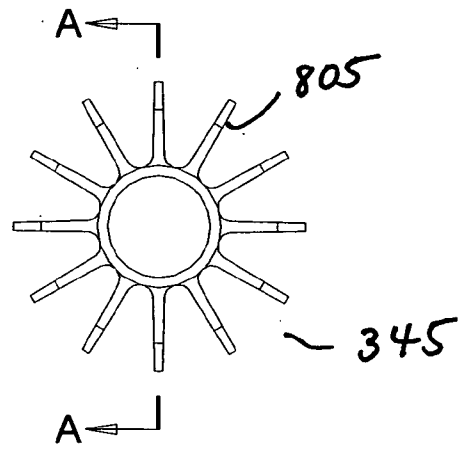

FIG. 8B

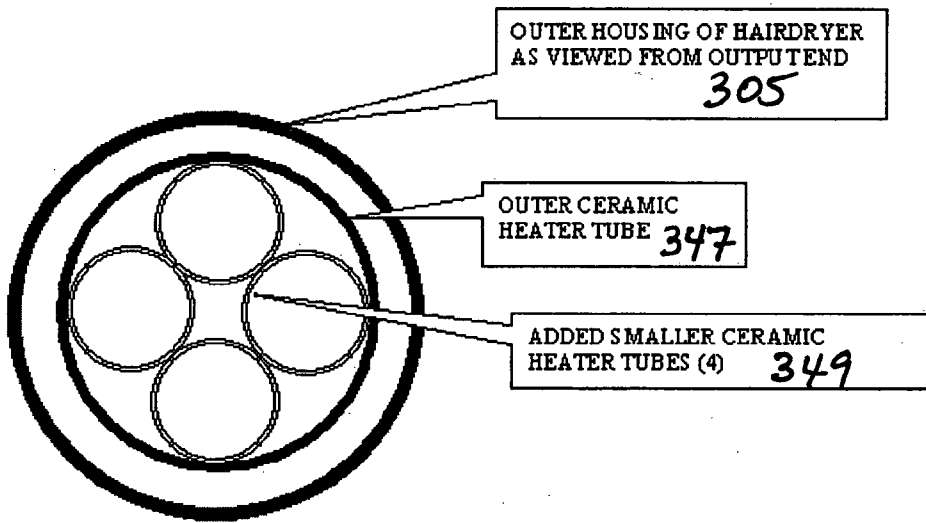

FIG. 9

1000

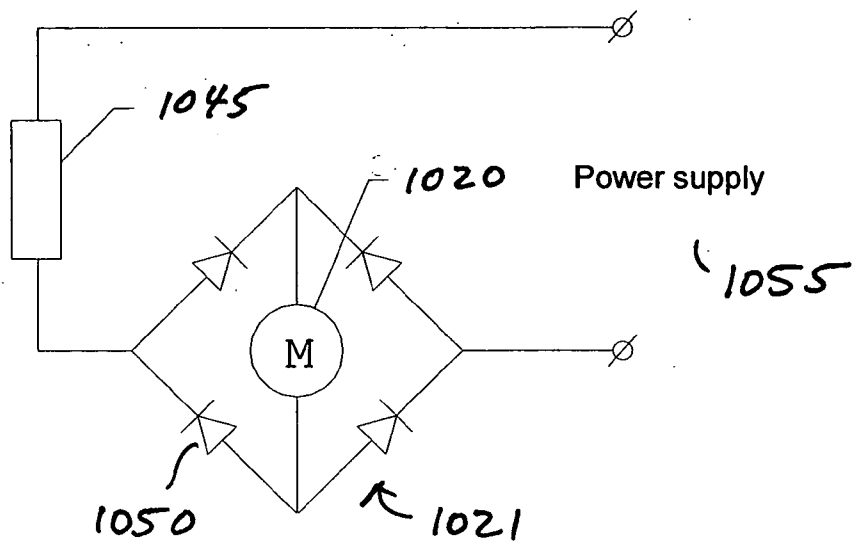

FIG. 10

1100

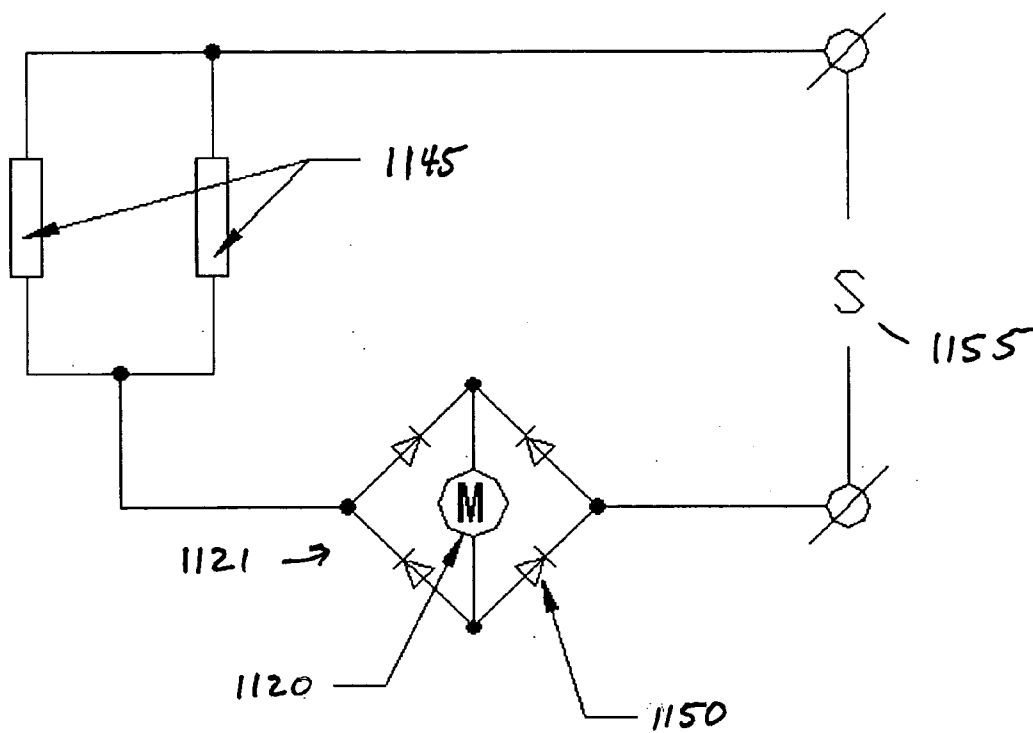

FIG. 11

1200

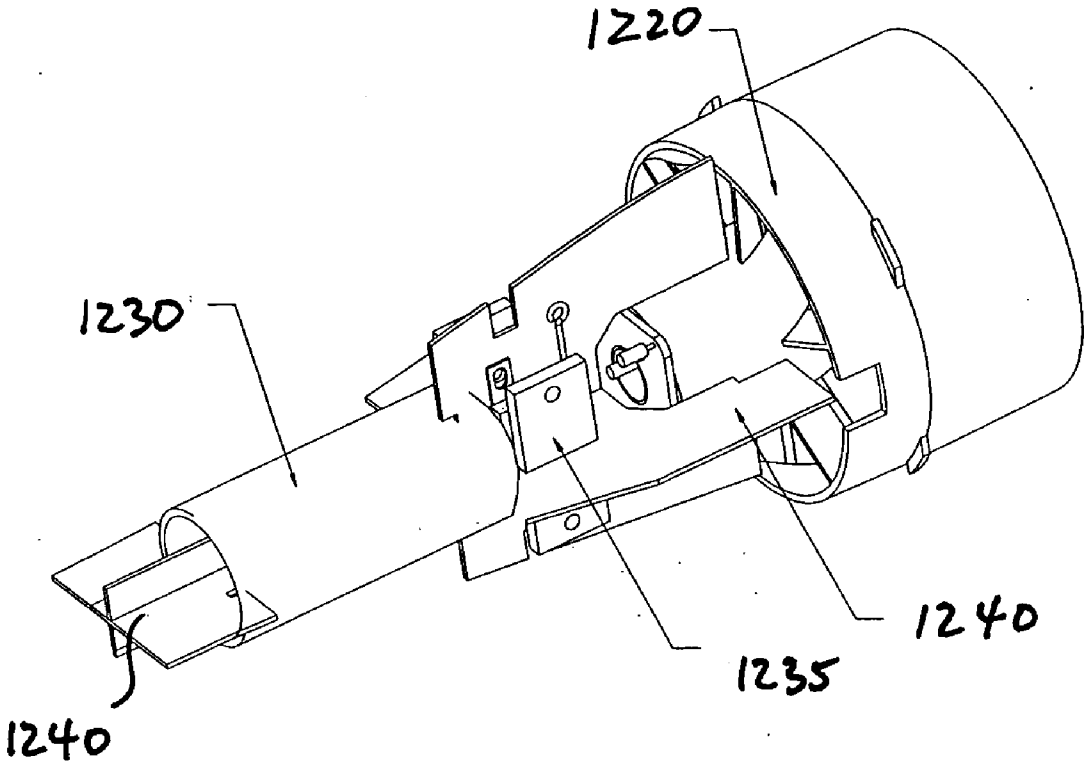

FIG. 12

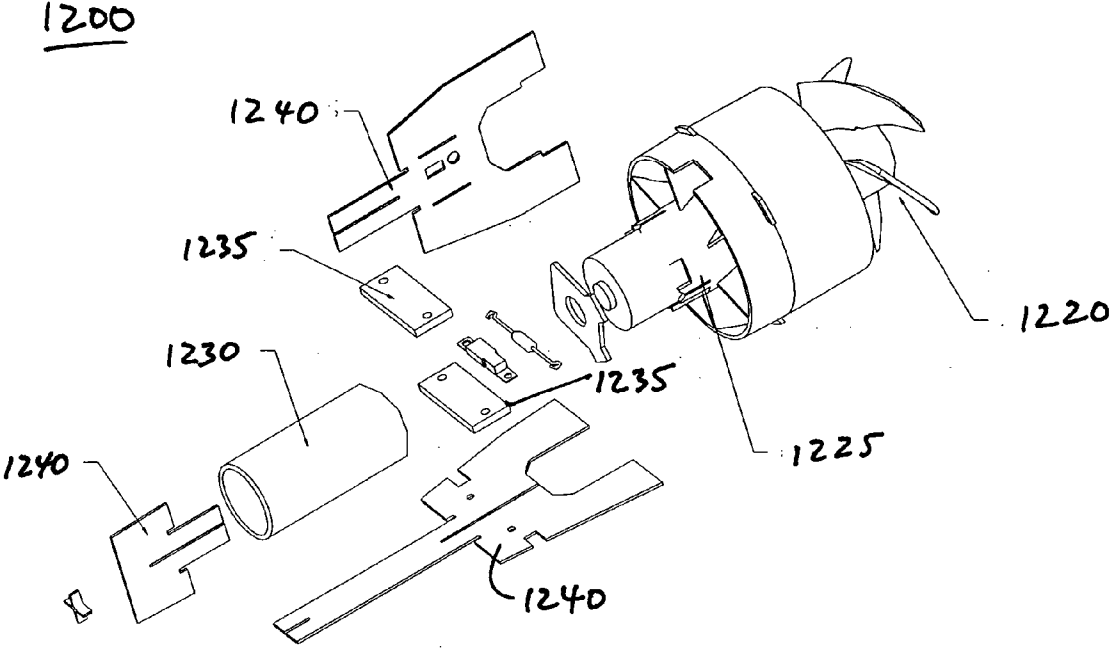

FIG. 13

HOT AIR BLOWER WITH CERAMIC HEATING ELEMENT

CROSS-REFERENCE TO RELATED APPLICATIONS

[0001] The present application is claiming priority of Chinese Patent Application No. 200520015978.1, filed on Apr. 18, 2005, the content of which is herein incorporated by reference.

BACKGROUND OF THE INVENTION

[0002] 1. Field of the Invention

[0003] The present invention relates to home appliances involving electric heating, and more particularly, to hair blowers and electric air heaters having heating elements.

[0004] 2. Description of the Related Art

[0005] Commonly used electric hot air blowers, such as electric hair dryers or air heaters for home heating in winter, generally employ nickel-chromium alloy wires wound around a mica bracket as a heater. FIG. 1 illustrates an inner structure of an existing electric hot air blower 100, where the electric heater is made of wound nickel-chromium alloy wires. Blower 100 includes a housing 105, an air inlet 110, an air outlet 115, a driving motor 120, a fan 125, and resistance heating wires 130 wrapped around a bracket 135. Resistance heating wires 130, when an electric current is applied thereto, heat up and heat air blown from fan 125 that contacts wires 130. FIG. 2 shows several common winding patterns of the existing electric hot air blower resistance wires 130. FIG. 2A shows a spring coil pattern, FIG. 2B shows a delta pattern, and FIG. 2C shows a long arc pattern of heating wires 130.

[0006] U.S. Pat. No. 6,378,225 B1, for example, discloses an air blower that uses a ceramic radiator, suspended on a bracket, that can emit far infrared radiation. Nickel-chromium resistance wires are wound around the ceramic radiator.

[0007] All the above-mentioned technological approaches aim to reduce noise by providing different winding patterns of resistance wires. Although some winding patterns do have some effect in the reduction of noise, their potential in this respect is very limited. Existing electric hot air blowers have the following disadvantages: long resistance wires, large space occupation, complex bracket structure, high air resistance and noise. Because the wires must be wound around a bracket, the winding of resistance wires can easily be made uneven, resulting in local over-heating, causing oxidation and breakage of resistance wires and shortening the service life of those electric hot air blowers. Another significant disadvantage is the fact that heater coils naturally fatigue, may break, and get "spit" out of a dryer, causing possible personal injury. Another cause of "spitting" is the fact that most heaters are hand wound, and a loose or poorly assembled coil may touch an adjacent coil, thereby causing a local drop in resistance, creating a hot spot resulting in near instant coil breakage and "spitting".

[0008] In addition, resistance wires emit light, resulting in a low efficiency in the conversion from electricity to heat and a consequent waste of energy. Current electric heaters having ceramic radiators are also inefficient, as electric heaters made up of nickel-chromium resistance wires heat the far infrared ceramic radiators indirectly, resulting in a low emission efficiency.

[0009] In addition, many motors driving fans in electric hot air blowers, whether they are AC or DC motors, must be equipped with voltage dropping devices, i.e., voltage converters. Other AC fan motors may also run at incoming line voltage, without reducing voltage. For example, many electric hot air blowers use DC motors operating at about 1.5 Volts to about 24 Volts, however, they are usually powered by DC supply converted from an AC 120V or 230V supply. At present, there are several methods of conversion for small home appliances and they all have their own disadvantages. Dropping voltage using resistors or capacitors requires that the resistors or capacitors be of a relatively large size. Coil transformers for dropping voltage suffer from the disadvantages of higher costs and large size. Another method includes dropping voltage using nickel-chromium resistance wires. Although this method is economical, the manufacturing process requires multiple stages and the resulting voltage dropping device is comparatively large.

SUMMARY OF THE INVENTION

[0010] It is an object of the present invention to provide an air heater having improved heating uniformity and reduced noise relative to current electric hot air blowers.

[0011] It is another object of the present invention to provide an air heater that incorporates voltage reduction devices having a minimal size and having a structure allowing simple assembly.

[0012] It is yet another object of the present invention to provide an air heater having a superior airflow capability.

[0013] It is still another object of the present invention to provide an air heater that produces heat by far infrared waves.

[0014] It is a further object of the present invention to provide an air heater having an efficient drying system that provides significant energy savings without loss of performance.

[0015] These and other objects of the present invention are achieved by a heating element for an electric air heater including an electric power source, a ceramic base, and a conductive heating film substantially uniformly deposited on at least a portion of a surface of the base and electrically connected to the power source. There is also provided a method for manufacturing the heating element.

[0016] There is also provided an electric hot air blower including a housing having an air inlet and an air outlet, a fan operatively connected to an electric motor, and an electric heating element located inside the housing that includes a ceramic base and a conductive film substantially uniformly deposited on a surface of the base and electrically connected to a power source. The electric heating element is aligned with an air flow path of the blower for heating air flow.

BRIEF DESCRIPTION OF THE DRAWINGS

[0017] FIG. 1 is a side cross-sectional view of a prior art hot air blower.

[0018] FIG. 2 is a front view showing variations of the hot air blower of FIG. 1, particularly showing several common winding patterns of resistance wires.

[0019] FIG. 3 is a side cross-sectional view of one embodiment of an electric hot air blower of the present invention including cylindrical ceramic elements constituting both a heater and a voltage dropping resistor for a driving motor.

[0020] FIG. 4 is a perspective view of the internal structure of the electric hot air blower of FIG. 3.

[0021] FIG. 5A is a side cross-sectional view, and FIG. 5B is a front cross-sectional view, of a cylindrical ceramic heating element according to the present invention.

[0022] FIG. 6A is a side cross-sectional view, and FIG. 6B is a front cross-sectional view, of a square tubular ceramic heating element according to the present invention.

[0023] FIG. 7A is a side cross-sectional view, and FIG. 7B is a front cross-sectional view, of a cone shaped ceramic heating element according to the present invention.

[0024] FIG. 8A is a side cross-sectional view along a plane represented by the line A-A, and FIG. 8B is a front cross-sectional view in a plane perpendicular to plane A-A, of a column-shaped heating element according to the present invention.

[0025] FIG. 9 is a front cross-sectional view of an embodiment of the heating element of the present invention having multiple interior components.

[0026] FIG. 10 is an electric schematic drawing, showing a single piece of a ceramic heating element as a voltage dropping resistor.

[0027] FIG. 11 is an electric schematic drawing, showing two pieces of ceramic heating elements incorporated as a voltage dropping resistor.

[0028] FIG. 12 is a perspective view showing the internal structure of a second embodiment of an electric hot air blower of the present invention, shown assembled.

[0029] FIG. 13 is a perspective view showing the internal structure of the electric air blower of FIG. 12, shown disassembled.

DESCRIPTION OF THE INVENTION

[0030] Referring to the drawings and, in particular, to FIGS. 3 and 4, there is provided an embodiment of an electric hot air blower, i.e., a hair dryer, of the present invention generally represented by reference numeral 300. Hair blower 300 utilizes a newly developed heating element, including conductive film or thin layer deposited on and preferably attached to a ceramic base, as an air heater.

[0031] Hair blower 300 includes a shell 305 with an air inlet 310 and an air outlet 315, a fan 320 operatively connected to a driving motor 325 assembled inside shell 305. Also mounted or assembled inside shell 305 is an electric heating element 330 for heating airflow and a power control assembly including a secondary/auxiliary heater and/or voltage dropping resistor 335. A bracket 340 holds heating element 330 and voltage dropping resistor 335 in position along an air flow path of hair blower 300. In one embodiment, resistor 335 acts as a dropping resistor, and may also act as a secondary heater. In another embodiment, resistor 335 acts only as a secondary heater.

[0032] Electric heating element 330 includes a ceramic base, upon whose surfaces are deposited a film that is preferably adhered to ceramic base. The combined thickness of the ceramic base and the film is preferably between about 0.8 mm to 1.5 mm. In a preferred embodiment, the combined thickness of the ceramic base and the film is about 1.2 mm. The film is an electrically conductive film having a resistance sufficient to produce a desired amount of heat upon

application of a selected current. Heating element 330, when heated, emits far infrared radiation.

[0033] When power is switched on, the resistance heating film on heating element 330 will be heated first, and then the ceramic base of heating element 330 is heated directly, which will emit far infrared radiation at high temperature to heat airflow passing over it. The heated air will be forced out of air outlet 315 by the airflow produced by fan 320, thus acquiring high electricity-heat conversion efficiency, high far infrared emission efficiency and less air resistance.

[0034] Hair Blower 300 also includes a power control assembly. Power control assembly includes a voltage dropping device 335 connected to driving motor 325. Dropping device 335 lowers the voltage from the higher voltage supplied by a power source, such as power accessed from a wall socket, to a lower voltage suitable for driving motor 325. Dropping device 335 preferably includes a heating element that includes a conductive resistance heating film deposited on a ceramic base as the voltage dropping resistor. Dropping device 335 is thus preferably of a similar structure as heating element 330, and materials used for the ceramic base and resistive film of dropping device 335 are preferably the same materials used for the ceramic base and resistive film of heating element 330.

[0035] Both heating element 330 and voltage dropping device 335 are mounted on a bracket 340 located between fan 320 and air outlet 315. Preferably, bracket 340 is a mica bracket.

[0036] Referring now to FIGS. 5A through 8B, heating element 330 includes a ceramic base piece 345 having a resistive heating film adhered to at least part of the surface of base piece 345. In one embodiment, the resistive heating film is deposited on all exterior surfaces of base piece 345. Base piece 345 can take any desired shape, such as a hollow cylinder shown in FIGS. 5A and 5B, a hollow square tubular shape shown in FIGS. 6A and 6B, and a hollow conical shape. An example of a conical shaped ceramic base piece 345 is shown in FIGS. 7A and 7B, in which the bore 705 is cylindrical and the external surface 710 is conic. Other shapes include a column or cylindrical shape having radially extending ribs or protrusions 805, as shown in FIGS. 8A and 8B. Electrodes (not shown) may be adhered to, or incorporated in, a part of the resistive heating film.

[0037] In one embodiment, ceramic base piece 345 includes a plurality of ceramic tubular structures surrounded by an exterior ceramic tubular structure. An example is shown in FIG. 9, in which ceramic base piece 345 includes an exterior ceramic base piece 347 and multiple ceramic interior base pieces 349. Preferably, the interior pieces 349 and the exterior piece 347 are made from the same material. Preferably, the conductive resistive heating film is applied only to the exterior of exterior piece 347, but the heating film may also be applied to portions of both the exterior piece 347 and the interior pieces 349. In this example, four hollow tubular interior ceramic pieces are shown, although any number may be used.

[0038] In a preferred embodiment, heating element 330 includes a conductive resistive heating film that is substantially uniformly deposited on a surface of the ceramic base, and is adhered to the ceramic base. The conductive film may be sintered onto the surface of the ceramic base. The conductive film preferably includes electrodes incorporated into or electrically connected to the conductive film for connection between heating element 330 and a power source.

[0039] In a preferred embodiment, ceramic base piece **340** is made of quality ceramic having a thickness of about 0.5 to 3.0 mm thick. In another embodiment, the ceramic material contains aluminum oxide. The resistive heating film may contain any of a number of compositions such as germanium, borosilicate, ytterbium oxide, a semiconductor ceramic far-infrared material, and bismuth oxide. Preferably, the resistive heating film does not contain any potentially harmful substances such as lead, mercury, hexavalent chromium, polyether, benzene, and benzoic acid.

[0040] In another preferred embodiment, the resistive heating film is made from a slurry that is adhered to ceramic base piece **340** by sintering. The expansion coefficient of the slurry is preferably substantially the same as that of the material of ceramic base piece **340**.

[0041] In a corresponding preferred method for manufacturing heating element **330**, the slurry is first applied to the selected surfaces of ceramic base piece **345**, preferably by spraying. After applied onto the selected surfaces, the slurry is sintered on the surfaces at a temperature of, e.g., about 1300° C. to form a uniform resistive heating film. Electrodes are then formed by applying additional slurry on the surface at preferably both ends of ceramic base piece **345** together with welding leads for electric connections. The additional slurry is then sintered at a high temperature, such as 1300° C. to firmly fix the electrodes to the resistive heating film.

[0042] The manufacturing requirements of dropping resistor **335**, constructed from the ceramic base and the resistive film are generally more stringent than those used for manufacture of heating element **330**. Many factors may influence physical properties of the resistance film, including ratios of germanium, borosilicate, ytterbium oxide, a semiconductor ceramic far-infrared material, bismuth oxide and, purity of bonding substance, particle size and degree of uniformity of the compositions, spraying thickness and technology. For example, if the resistive film is not uniformly applied to the ceramic base of dropping resistor **335**, the DC motor may change its rotating speed continuously and the DC current may vary, thus causing great noise and shortening the motor's service life. Resistive film should be sprayed on or applied to the ceramic base to ensure a uniform resistive film to ensure stable resistance value and thus stable rotation speed of the DC motor, based on different power and voltage requirements of the motors.

[0043] The voltage applied to driving motor **325** inside electric hot air blower **300** should not be too high, and is preferably at a level of about 24 V (DC) or below, which is generally converted from AC 10V or 220V.

[0044] FIGS. **10** and **11** are circuit diagrams showing embodiments of the electrical setup of dropping device **335** and motor **325**. Referring to FIG. **10**, an embodiment of a circuit **1000** is shown wherein a dropping resistor **1045** includes only one piece of a heating element that includes a ceramic base having a conductive resistive heating film adhered to its surface. Dropping resistor **1045** is electrically connected to a motor **1020** in serial in circuit **1000**, which comprises four diodes **1050** to form a rectifier circuit **1021**. In this embodiment, the heating element is connected in serial in circuit **1000** with the DC motor **1020** that drives a fan in the air blower. AC power voltage is dropped by dropping resistor **1045** prior to reaching the rectifier circuit input terminal, and DC voltage is thus supplied to the DC motor **1020** from the output terminal.

[0045] FIG. **11** shows a circuit where two pieces of heating elements, each including a ceramic base having a conductive

heating film adhered to its surface, are connected in parallel in a circuit **1100** as dropping resistors **1145** for a motor **1120** that drives a fan in the air blower. Motor **1120** includes four diodes **1150** to form a rectifier circuit **1121**, which is connected to a power supply **1155**. Other connections in circuit **1100** are similar to those of circuit **1000**. Dropping resistors **1145** in this embodiment are connected in parallel in circuit **1100** with the DC motor **1120** driving the fan. In another embodiment, dropping resistors can also be used in conjunction with an AC motor to drive the fan. While the heating elements are used in the above embodiments as dropping resistors, they also act as an auxiliary heater to the electric hot air blower, providing additional air heating capability.

[0046] Referring now to FIGS. **12** and **13**, an alternative embodiment of the hair blower **300** is provided, generally represented by reference numeral **1200**. Hair blower **1200** includes a fan **1220** operatively connected to a driving motor **1225**, an electric heating element **1230** for heating airflow and a voltage dropping resistor **1235**. Bracket **1240** holds heating element **1230** and voltage dropping resistor **1235** in position along an air flow path of hair blower **1200**.

[0047] This embodiment is similar in construction to the hair blower of FIGS. **3** and **4**. However, dropping resistors **1235** are provided as two separate pieces secured to a bracket **1240**. Dropping resistors **1235** are shown as two flat rectangular pieces, although other shapes, sizes and numbers may be utilized. Heating element **1230** and dropping resistors **1235**, each of which include a ceramic base having a conductive film deposited and/or adhered to its surface, are assembled inside a shell of hair blower **1200** (not shown), by way of a mica bracket **1240**.

[0048] Heating element **1230** acts to heat air blowing from fan **1220** to an outlet, and dropping resistors **1235**, in the form of rectangular strips in the present embodiment, act as both dropping resistors for the driving motor of fan **1220** and as auxiliary heaters. In the embodiments described above, the heating elements and dropping resistors are provided as separate components. In another embodiment, a single heating element can be utilized to act as both a heater and a dropping resistor. In this embodiment, a heating element having a ceramic base with a conductive heating film is provided to heat airflow, and a selected portion of the conductive heating film in the heater makes a dropping resistor for the motor. This alternate configuration results in a simpler and more compact structure of the hot air blower. The heating element has numerous advantages, including the physical properties of uniform heat generation and far infrared emission. The heated ceramic base can directly emit strong far infrared that has healthcare function. The heating element's flat and smooth surface also induces less air resistance, resulting in a more efficient air blower. The heating element features large surface area and low air resistance. As air resistance is low and air passage is smooth, rotation speed of the fan can be reduced, leading to reduction of noises. Furthermore, avoidance of resistance coils avoids the disadvantages inherent therewith, such as uneven heating and "spitting".

[0049] Because the conductive surface heating film is preferably sintered onto the ceramic base after the resistance slurry material is sprayed on surface of said ceramic base, the film is uniform, thus resulting in even temperature distribution and long service life.

[0050] Because of high conversion efficiency from electricity to heat and less power for the fan, energy is saved

with the air blower. Furthermore, when the heating element is used as dropping resistor in the motor-controlling circuit, the air blower can be reduced in size and cost, and can simplify assembly.

[0051] Another advantage is due to the fact that heaters of the present invention can produce and utilize a laminar airflow. These units channel the air through the front of the dryer, with minimal turbulence. A conventional wire heater creates turbulence to effectively heat the air and avoid troublesome hot spots that fatigue and break wires. Therefore turbulence is a necessity in prior art wire coil dryers, and does not create a smooth passage of air through the grill. The nature of the heating tubes of the present invention creates superior airflow with reduced turbulence, with actually less fan speed, that also increases the life of the dryer motor. Reduced turbulence results in easier airflow from the fan to the air outlet, allowing the fan to be run at a slower speed, resulting in energy savings and an increase in the life of the dryer.

[0052] It should be understood that various alternatives, combinations and modifications of the teachings described herein could be devised by those skilled in the art. The present invention is intended to embrace all such alternatives, modifications and variances that fall within the scope of the appended claims.

What is claimed is:

- 1. A heating element for an electric air heater, comprising:
 - an electric power source;
 - a ceramic base; and
 - a conductive heating film substantially uniformly deposited on at least a portion of a surface of said base and electrically connected to said power source.
- 2. The heating element of claim 1, wherein said electric heater emits far infrared radiation when heated to a selected temperature.
- 3. The heating element of claim 1, wherein said conductive film includes electrodes adhered onto a portion of said surface of said ceramic base.
- 4. The heating element of claim 1, wherein said ceramic base is made from ceramic material containing aluminum oxide.
- 5. The heating element of claim 4, wherein said ceramic base has a thickness between about 0.5 mm and 3 mm.
- 6. The heating element of claim 1, wherein said conductive heating film is deposited on an exterior surface of said ceramic base.
- 7. The heating element of claim 1, wherein said ceramic base has a shape selected from the group consisting of: cylindrical, tubular, square tubular, conical, and columnar.
- 8. The heating element of claim 7, wherein said ceramic base has a cylindrical shape having radially extending ribs or protrusions.
- 9. The heating element of claim 7, wherein said ceramic base includes a plurality of ceramic tubular structures surrounded by an exterior ceramic tubular structure.

- 10. An electric hot air blower comprising:
 - a housing having an air inlet and an air outlet;
 - a fan operatively connected to an electric motor; and
 - an electric heating element located inside said housing that includes a ceramic base and a conductive film substantially uniformly deposited on at least a portion of a surface of said base and electrically connected to a power source,
 wherein said electric heating element is located along an air flow path of said blower for heating air flow.
- 11. The hot air blower of claim 10, further comprising a power control assembly including a voltage dropping device electrically connected to said electric motor, wherein said voltage dropping device includes a second ceramic base and a second conductive film substantially uniformly deposited on at least a portion of a surface of said second base and electrically connected to said motor.
- 12. The hot air blower of claim 10, wherein said electric heating element heats said air flow and acts as a voltage dropping resistor device to reduce a voltage applied to said motor from said power source.
- 13. The hot air blower of claim 10, wherein said conductive film includes electrodes adhered onto part of said surface of said ceramic base.
- 14. The hot air blower of claim 10, wherein said conductive heating film is deposited on an exterior surface of said ceramic base.
- 15. The hot air blower of claim 10, wherein said ceramic base has a shape selected from the group consisting of: cylindrical, tubular, square tubular, conical, and columnar.
- 16. The hot air blower of claim 10, wherein said heating element is installed on a bracket located between said fan and said air outlet.
- 17. The hot air blower of claim 11, wherein said voltage dropping device is selected from the group consisting of: one or more dropping resistor elements connected in series with said motor, and at least two dropping resistor elements connected in parallel with said motor.
- 18. A method for manufacturing a heating element for a hot air blower, comprising the steps of:
 - depositing a conductive heating film on at least a portion of a surface of a ceramic base; and
 - forming electrodes in electrical contact with said conductive film for connection to an electric power source.
- 19. The method of claim 18, further comprising the step of adhering said film to said surface by sintering.
- 20. The method of claim 19, wherein said step of depositing is accomplished by spraying a slurry of conductive material to said surface.

* * * * *