

- [54] **ARRANGEMENT FOR RETAINING ELECTRICAL CONNECTOR INSERT**
- [75] Inventor: **Kenneth M. Clark**, Beaumont, Calif.
- [73] Assignee: **The Deutsch Company, Electronic Components Division**, Banning, Calif.
- [22] Filed: **Feb. 25, 1974**
- [21] Appl. No.: **445,108**

Related U.S. Application Data

- [60] Division of Ser. No. 167,317, July 29, 1971, Pat. No. 3,727,172, which is a continuation-in-part of Ser. No. 83,782, Oct. 26, 1970, abandoned.
- [52] U.S. Cl. **339/90 R**
- [51] Int. Cl. **H01r 13/54**
- [58] Field of Search 339/89, 90, 94

- [56] **References Cited**
- UNITED STATES PATENTS**
- 3,493,670 2/1970 Broadbelt et al. 339/94 M

Primary Examiner—Joseph H. McGlynn
Attorney, Agent, or Firm—Gausewitz, Carr & Rothenberg

[57] **ABSTRACT**

An electrical connector that includes an insert assembly held in the shell by means of outwardly projecting lugs on the insert that are rearwardly moved through longitudinal slots in the shell upon assembly, followed by rotation of the insert to position the lugs between opposed shoulders on the shell, which thereby prevents relative axial movement of the shell and insert.

3 Claims, 15 Drawing Figures

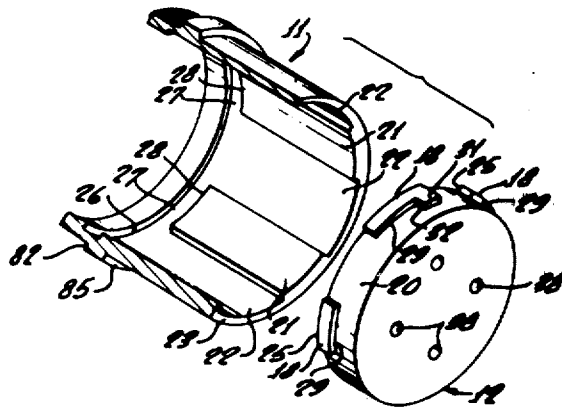

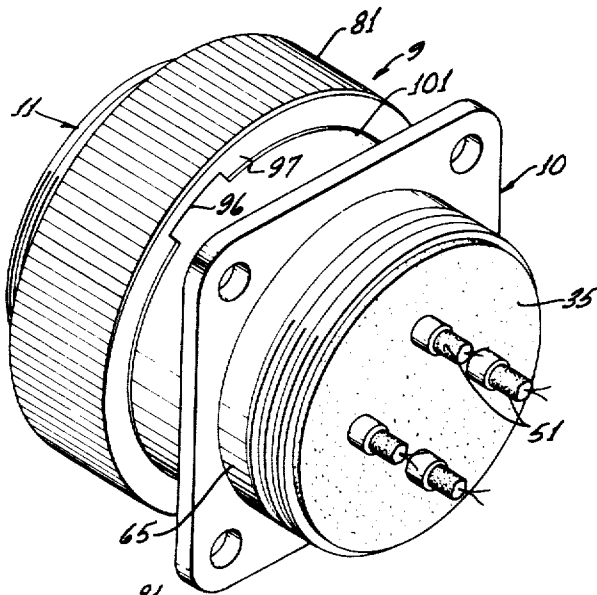

FIG. 1.

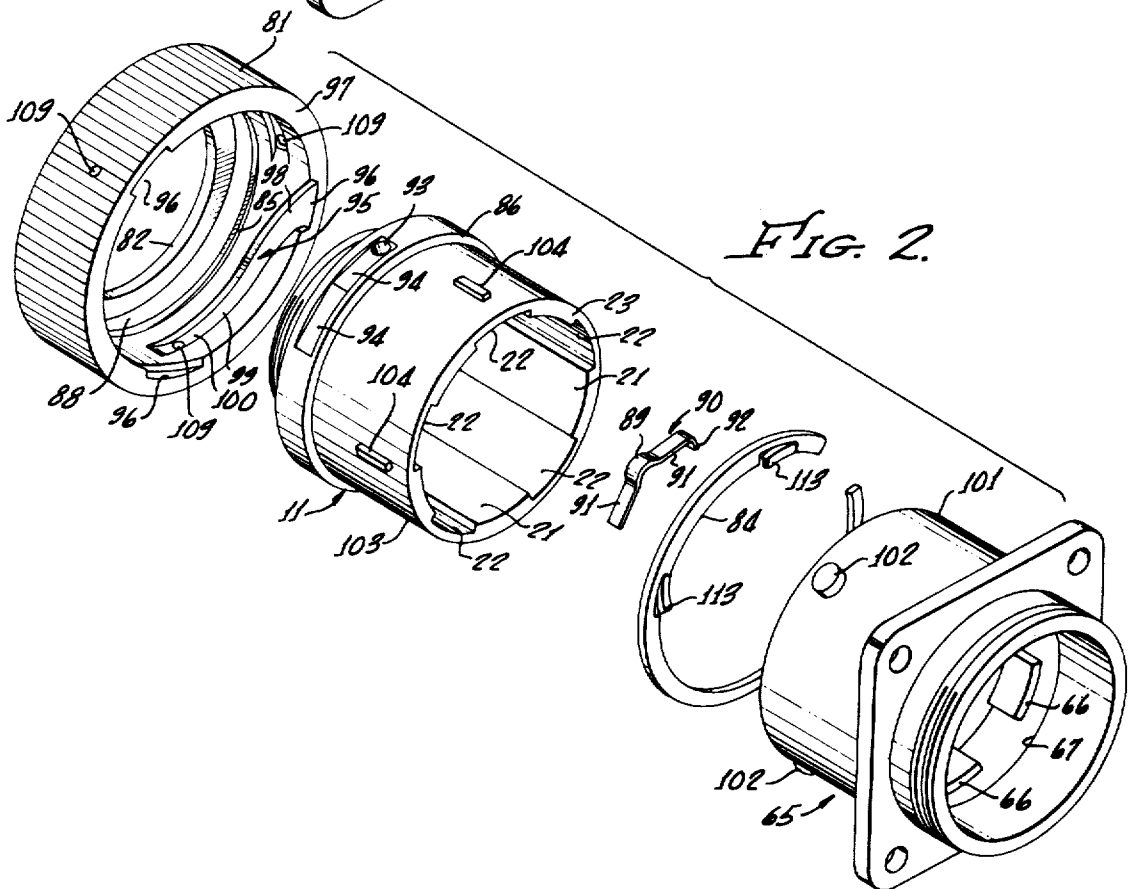

FIG. 2.

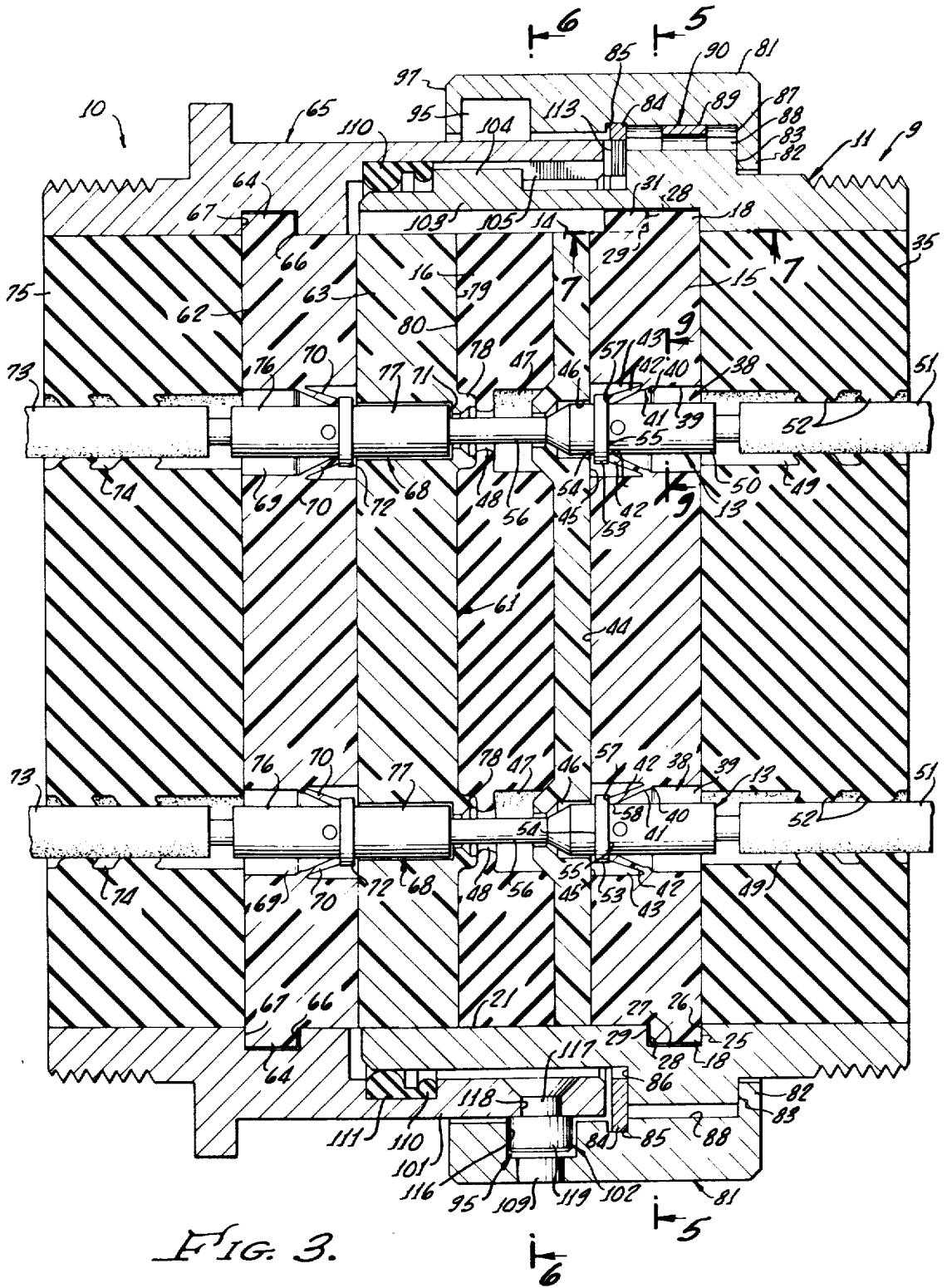

FIG. 3.

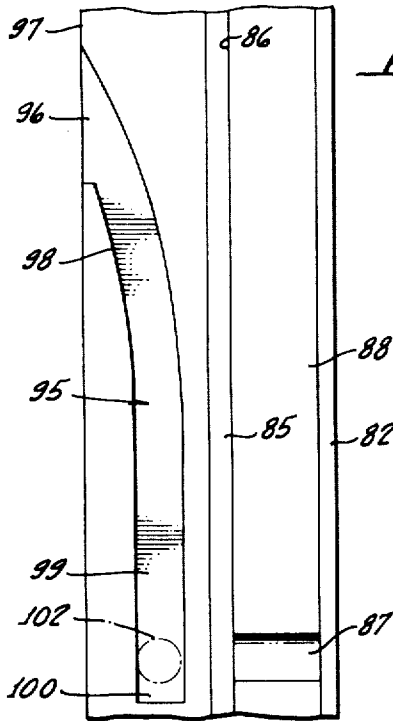

FIG. 14.

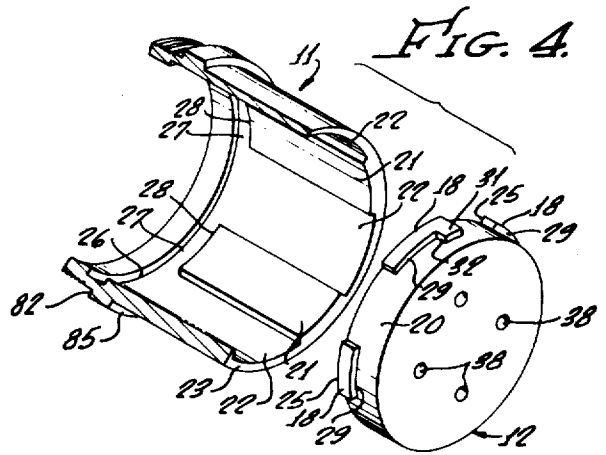

FIG. 4.

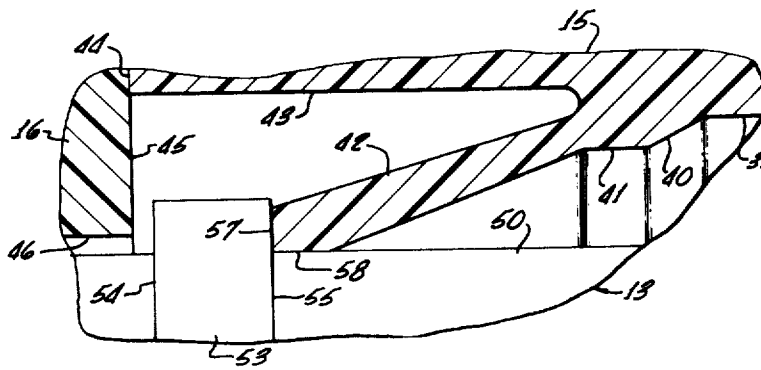

FIG. 10.

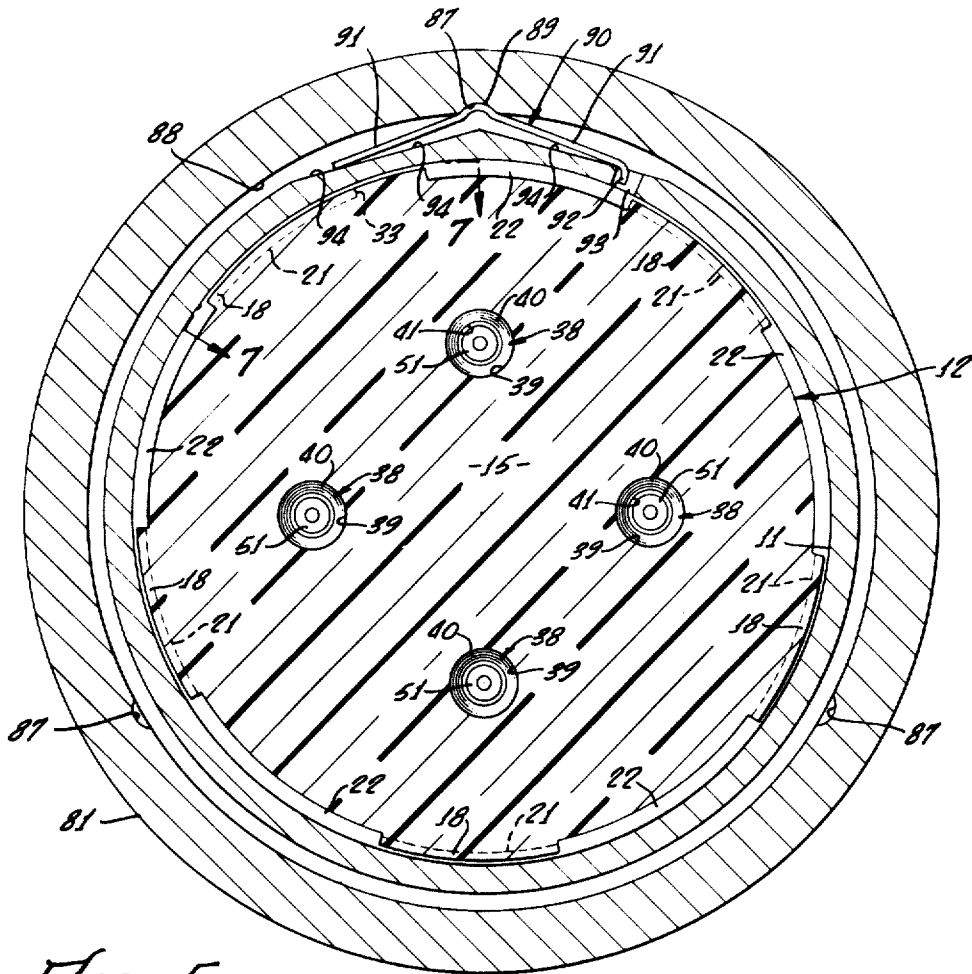

FIG. 5.

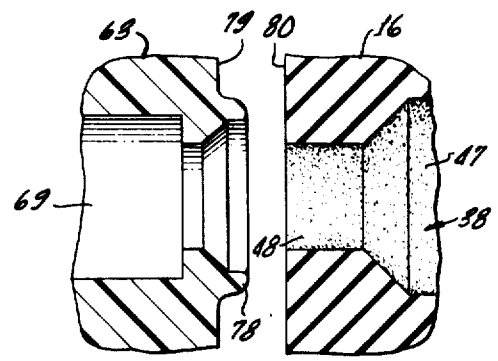

FIG. 13.

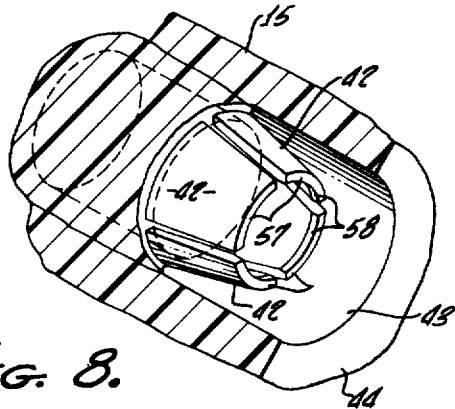

FIG. 8.

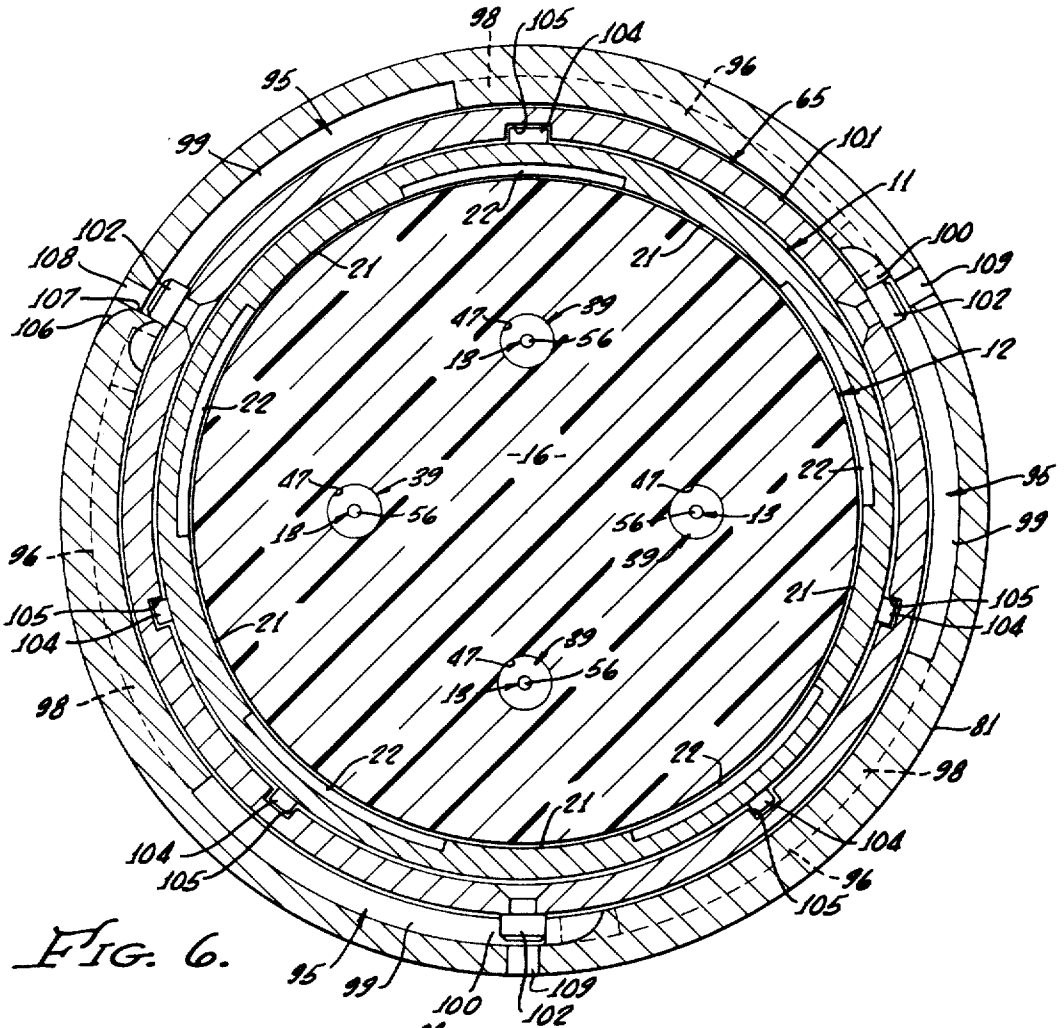

FIG. 6.

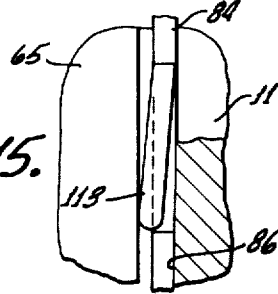

FIG. 15.

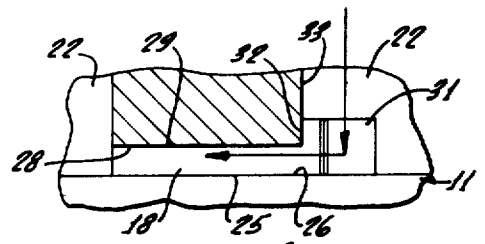

FIG. 7.

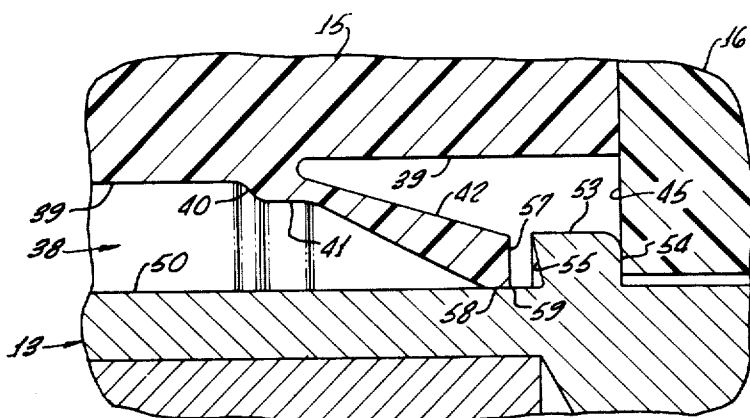

FIG. 11.

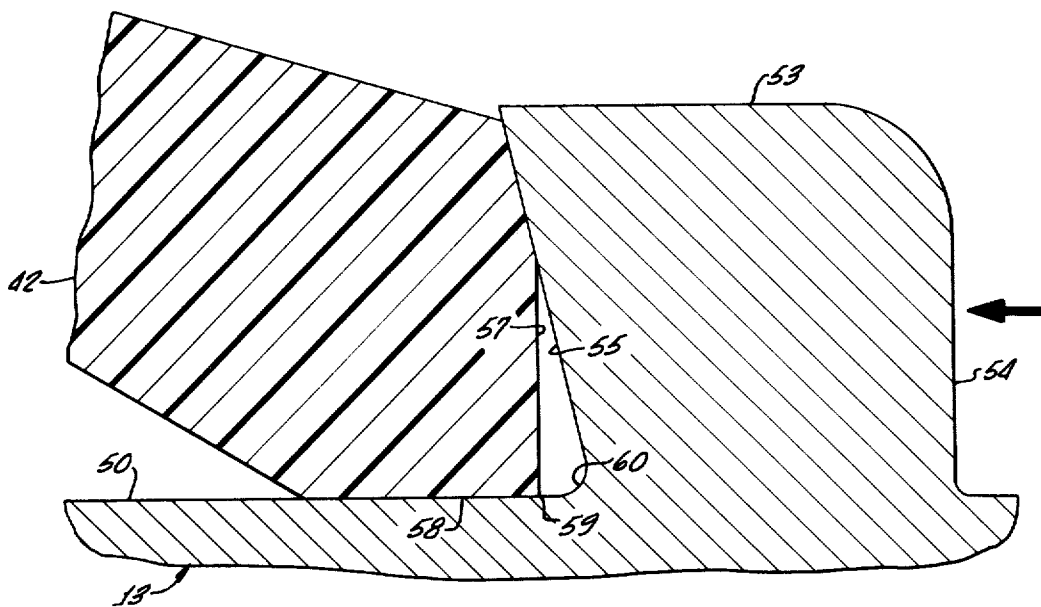

FIG. 12.

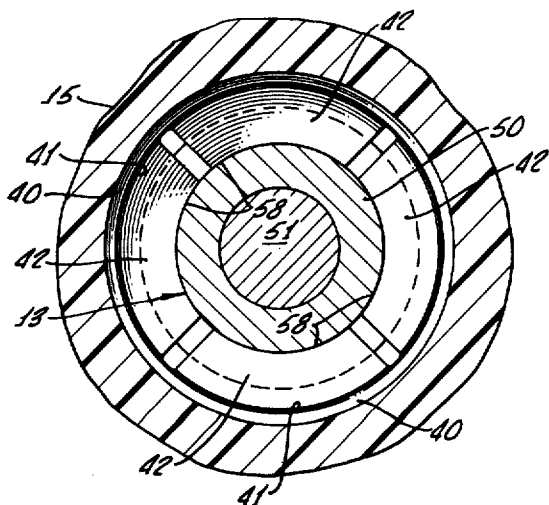

FIG. 9.

ARRANGEMENT FOR RETAINING ELECTRICAL CONNECTOR INSERT

REFERENCE TO RELATED APPLICATIONS:

This is a division of my copending patent application Ser. No. 167,317, filed July 29, 1971, for Electrical Connector, now U.S. Pat. No. 3,727,172, which is a continuation-in-part of application Ser. No. 83,782, filed Oct. 26, 1970, now abandoned.

BACKGROUND OF THE INVENTION

1. Field of the Invention

This invention relates to electrical connectors.

2. Description of Prior Art

Electrical connectors conventionally include a plug and receptacle, each of which has an insert of dielectric material provided with multiple openings within which the electrical contacts are retained. The insert is introduced from the rearward end into a metallic shell, where it is held against an abutment by means of a nut. The nut is subject to loosening during service, so that there is no positive assurance of retention of the insert. Such loosening of the nut will allow the insert to move rearwardly even when the plug and receptacle are coupled, and can result in the separation of the contacts and the interruption of their electrical circuits. Also, this arrangement for retaining the insert wastes space within the shell, adding to the size of the connector.

SUMMARY OF THE INVENTION

The present invention provides an improved electrical connector which overcomes the difficulties outlined above. In this connector, the insert is held in the shell by immovable abutments rather than a nut so that the insert will not become loosened while the connector is in service. This is accomplished by including spaced longitudinal grooves in the inner circumferential surface of the shell, which extend rearwardly from the forward end to an annular shoulder adjacent the rearward end. Circumferential recesses communicate with the longitudinal grooves and define additional abutments adjacent the annular shoulder. Lugs project outwardly from the insert and slide through the longitudinal grooves as the unit is assembled by moving the insert into the shell from the forward end. When the lugs have reached the annular shoulder, the insert is rotated to position the lugs in the circumferential recesses between the shoulder and the abutments. A suitable connection, such as bonding, holds the insert against reverse rotation.

This construction means that the inserts cannot move rearwardly past the annular shoulder, so that the inserts are held positively under vibrational and other loads imposed during use. Once the connector has been coupled, the inserts will remain fixed and cannot move so as to disengage the contacts. Also, by assembling the insert from the forward end, more available space is provided inside the shell, increasing the number of contacts that may be included in a connector of a given size. Virtually the entire interior dimension of the plug shell can be used in retaining contacts, allowing the receptacle shell, where excess space necessarily is present, to accommodate a comparably increased number of contacts.

BRIEF DESCRIPTION OF THE DRAWINGS

FIG. 1 is a perspective view of an electrical connector made in accordance with this invention;

FIG. 2 is an exploded perspective view of certain portions of the connector, including in particular the parts used for coupling the plug and receptacle;

FIG. 3 is an enlarged longitudinal sectional view of the connector in the mated position;

FIG. 4 is an exploded perspective view, partially broken away, of the plug insert and shell;

FIG. 5 is a transverse sectional view taken along line 5—5 of FIG. 3;

FIG. 6 is a transverse sectional view taken along line 6—6 of FIG. 3;

FIG. 7 is a fragmentary sectional view taken along line 7—7 of FIG. 5;

FIG. 8 is a fragmentary enlarged perspective view of one portion of the plug insert assembly, illustrating the contact retention fingers;

FIG. 9 is a fragmentary transverse sectional view taken along line 9—9 of FIG. 3;

FIG. 10 is an enlarged fragmentary view illustrating the details of the finger shape and its engagement with the contact;

FIG. 11 is a fragmentary longitudinal sectional view showing the retention finger spaced from the contact shoulder when the contact is shifted forwardly;

FIG. 12 is a further enlarged fragmentary view illustrating the engagement between the retention finger and the contact shoulder, with the contact under rearward load;

FIG. 13 is an enlarged fragmentary longitudinal sectional view of the forward portions of the inserts of the plug and receptacle, shown slightly separated and illustrating the sealing arrangement for the openings;

FIG. 14 is a fragmentary flat pattern of the inside of the coupling ring, showing one of the bayonet grooves; and

FIG. 15 is an enlarged fragmentary sectional view taken along line 15—15 of FIG. 3, illustrating the engagement of the spring tab on the snap ring and the forward end of the receptacle shell.

DESCRIPTION OF THE PREFERRED EMBODIMENT

Illustrated in the drawing is a multiple pin and socket connector that includes a plug 9 and a receptacle 10. The general arrangement for retaining the contacts is the same in the plug and receptacle. In the embodiment illustrated, the pin contacts are in the plug and the socket contacts in the receptacle, although this may be reversed if desired. The plug 9 includes a plug shell 11, which is a generally tubular metal member of circular cross section. Within the shell 11 is an insert assembly 12 that serves to retain and hold a plurality of pin contacts 13. The insert assembly 12 includes disks 14 and 15 of a substantially rigid plastic. A suitable material for these members, because of its strength and temperature-resistance, is a polyarylsulfone marketed under the trademark "Astrel" 360 plastic by Chemical Division, 3M Company, 3M Center, St. Paul, Minnesota. The disks 14 and 15 are suitably bonded together at their mating radial faces. At the forward end of the insert assembly 12 is bonded a gasket disk 16 of a resilient elastomeric material, such as silicone rubber.

The insert assembly 12 is retained in the plug shell 11 by means of interengaging castellations on the insert assembly and the plug shell. For this purpose, there are circumferentially extending lugs 18 that project outwardly from the periphery of the rearward disk 15, as seen in FIG. 4. In the embodiment illustrated, there are five of the lugs 18. The circumferential surface 20 from which the lugs 18 project is substantially complementary to the inner surface 21 of the plug shell 11. The slots 22 are made sufficiently wide to permit the insert assembly 12 to be introduced into the plug shell 11 by being slid inwardly from the forward end 23 of the plug shell, with the lugs 18 passing through the slots 22. The insert assembly 12 is moved into the plug shell until the rearward radial edges 25 of the lugs 18 are brought into engagement with an annular shoulder 26 at the rearward portion of the plug shell.

Circumferential slots 27 are formed at the rearward portion of the inner surface 21 of the plug shell 11, and are of widths substantially equal to the widths of the lugs 18. This provides circumferentially extending shoulders 28 spaced opposite from the annular shoulder 26 of the plug shell. The shoulders 26 and 28 are spaced apart a distance corresponding to the dimensions of the lugs 18 longitudinally of the insert assembly 12. This allows the insert assembly 12 to be rotated after the rearward edges 25 of the lugs 18 have been brought into engagement with the annular shoulder 26. The rotation of the insert assembly brings the lugs 18 in back of the circumferential shoulders 28 and into the circumferential slots 27. This positions the forward edges 29 of the lugs adjacent the circumferential shoulders 28 so that the radial shoulders 26 and 28 of the plug shell 11 hold the insert assembly 12 against longitudinal movement relative to the plug shell.

One of the lugs 18 may include a longitudinally forwardly projecting portion 31 having a side edge 32 which is brought into engagement with the side edge 33 of one of the longitudinal slots 22 in the plug shell for thereby limiting the rotational movement of the insert assembly 12 (see FIGS. 4 and 7). When the forward projection is provided, it assures that the insert assembly 12 assumes the proper rotational alignment relative to the plug shell. After being properly positioned in the plug shell 11, the insert assembly is locked in place so as to prevent it from being given reverse rotation. This may be accomplished by bonding the insert assembly to the plug shell.

With the insert assembly positioned in this manner, a rearward sealing element 35 made of a resilient elastomer, such as silicone rubber, is bonded to the rearward radial face of the insert assembly and to the rearward portions of the inner circumferential wall 21 of the plug shell.

The pin contacts 13 are received in spaced parallel openings 38 formed in the insert assembly 12. The openings 38 are continuous from the front to the rear of the insert assembly 12, and are separated from each other so that there is no communication from one opening 38 to the other. The connector is designed so that a large number of the pin contacts 13 may be retained in close adjacency, but, for clarity of illustration, only a relatively few such contacts are shown in the drawing.

Each opening 38 includes a relatively wide-diameter portion 39 at the rearward end of the plastic disk 15 which, through a frustoconical portion 40, tapers for-

wardly to a portion 41 of smaller diameter. A plurality of fingers 42 extends radially inwardly and axially forwardly from the portion 41 of the opening 38 into the continuation 43 of the opening 38 in the member 15. This positions the fingers 42 inwardly and radially opposite the circumferential wall of the portion 43 of the opening 38. The fingers 42 are shorter than the section 43 of the opening, so that their forward ends are inward of the forward radial face 44 of the member 15. There are four of the fingers 42 in the example shown, as illustrated in FIG. 8. The fingers 42 are rounded transversely so that collectively they define a generally frustoconical shape with narrow spaces between adjacent fingers. While the plastic member 15 is relatively hard and rigid, the fingers 42 are thin and, therefore, resilient. A radial shoulder is formed by the rearward face 45 of the member 14 where the diameter of the opening decreases at portion 46. In the gasket member 16, the opening has a relatively wide-diameter portion 47 at the rearward end and a smaller-diameter portion 48 at the forward end.

An opening 49 in the rearward sealing member 35 communicates with each of the openings 38.

The pin contacts 13 may be of conventional construction, including hollow, longitudinally elongated barrel portions 50 at their rearward ends, which receive the ends of wires 51 from which the insulation has been stripped. The contact barrels 50 are crimped to the wires 51 to form a mechanical and electrical connection. The wires 51 enter the openings 38 through the openings 49 in the rearward member 35, being engaged by annular sealing beads 52 formed on the circumference of the opening 49.

Forwardly of the barrel portion 50, each contact 13 includes a part 53 of enlarged diameter which defines forward and rearward shoulders 54 and 55, respectively. Beyond the forward shoulder 54, the contact narrows to a projecting pin portion 56 that is adapted to enter the socket contact. When installed in the opening 38, the forward shoulder 54 of the contact is adjacent the rearwardly facing shoulder defined by the rearward face 45 of the insert 14, which thereby prevents forward movement of the contact 13.

In this manner, the contact is positioned within the insert assembly and securely retained. With the use of the integral fingers 42, it is unnecessary to provide any auxiliary metal clip for retaining the contact, as in conventional connector construction. This simplifies the manufacture of the connector and lowers its cost. The danger of an improperly installed retainer clip is obviated. With the fingers 42 being entirely received in the section 43 of the opening 38, which locates them rearwardly of the forward face 44 of the disk 15, the bonding together of the inserts 14 and 15 will not adversely affect the fingers. In other words, the fingers are remote from the bond line so that any excess bonding material squeezed out at the joint will not interfere with the movement of the fingers.

As best seen in the enlarged illustration of FIG. 10, the fingers 42 are thicker in cross section at their forward ends than they are at their points of attachment to the insert 15, being tapered gradually in thickness to the rear. Also, each finger has a substantially radial forward end surface 57 which connects at a right angle to an inner end surface 58, which is a cylindrical segment generally complementary to the barrel 50 of the contact 13. When the finger 42 engages the contact 13,

the radial end surface 57 fits behind the rearward shoulder 55 of the contact, while the inner end surface 58 of the finger rests upon the barrel 50 adjacent the shoulder 55.

The rearward transverse shoulder 55 of the contact 13 does not fall within a radial plane. Instead, it is inclined toward the forward end of the contact. Consequently, the shoulder 55 is undercut, being defined by a frustum of a cone. Desirable results are achieved when the shoulder 55 is inclined at around 12° relative to a radial plane. When the contact 13 is subjected to a force pushing it toward the rear, the undercut shoulder configuration and the inner finger surfaces 58 contribute greatly to the amount of force which can be absorbed before the retention fingers 42 will fail.

With the arrangement of this invention, the fingers 42, loaded as columns, receive the forces on them near the neutral centers of the columns, minimizing the tendency to buckle. The plastic of the fingers 42, being softer than the metal of the contact 13, becomes distorted where it engages the radially outer portion of the shoulder 55, as illustrated in particular in the enlarged view of FIG. 12. This has the effect of embedding the shoulder in the outer ends of the plastic fingers 42, stabilizing the finger ends. This increases the column strength of the fingers 42 because a column can withstand more loading if its ends are stabilized.

An additional stabilizing effect is realized because of the arcuate inner surfaces 58 of the fingers 42 substantially complementarily engaging the periphery of the barrel 50 of the contact adjacent the base of the shoulder 55. This helps to anchor the free ends of the fingers. The inclined configuration of the shoulder 55 results in a force component on the fingers 42 helping to hold the surfaces 58 tightly against the circumference of the barrel 50 to enhance the column stabilizing effect.

The greater wall thickness of the fingers at their outer ends adds to their strength in shear and in bending. The bending strength resists the buckling of the fingers under load.

Another advantage comes from the fact that the inner corner 59 of the finger 42, between the end surface 57 and the inner surface 58, becomes spaced rearwardly from the fillet 60, which necessarily is formed between the shoulder 55 and the barrel 50 when the contact 13 is machined. When there is a straight radial shoulder, the inner corners of the retention fingers will engage the fillet at the base of the shoulder. This deflects the fingers outwardly, thereby tending to cam the fingers out of engagement with the shoulder. The undercut shoulder 55 permits the finger to clear the fillet 60 without requiring a recess in the finger and without sacrifice in the strength of the fingers.

The insert assembly 61 for the receptacle 10 includes a plastic disk 62 that is similar to the member 15. To it is bonded or otherwise suitably secured a forward cover disk 63. The members 62 and 63 also may be made of "Astrel" 360 plastic. Outwardly projecting lugs 64 on the disk 62 correspond to the lugs 18 on the member 15. The lugs 64 secure the insert assembly 61 to the receptacle shell 65 in the same way that the lugs 18 attach the insert assembly 12 in the plug shell 11. The insert assembly 61 is introduced into the receptacle shell 65 by passing the lugs 64 through axial grooves in the inner surface of the receptacle shell 65, whereupon subsequent rotation of the insert assembly 61 places the lugs 64 between opposed forward and rear-

ward shoulders 66 and 67, respectively, in the receptacle shell. This holds the disk 62 and the cover element 63 within the receptacle.

The socket contacts 68 are retained in continuous separate openings 69 in the insert assembly of the receptacle, positioned against axial rearward movement by integral fingers 70 that project forwardly and inwardly from the insert disk 62. A shoulder 71 on the insert member 63, where the opening 69 reduces in width, is adjacent the forward end of the contact 68 and precludes forward movement of the contact. The fingers 70 are engageable with the rearward edge of the annular enlargement 72 on the socket contact. A wire 73 extends inwardly through an opening 74 in the rearward sealing member 75 of the receptacle 10 for each of the socket contacts 68. The end portions of the wires 73 are stripped of insulation and connected by crimping to the rearward barrel ends 76 of the socket contacts 68. When the forward ends 77 of the socket contacts receive the projecting pin portions 56 of the pin contacts 13 upon the mating of the connector, circuits are completed between the wires 51 and 73.

A rounded annular bead 78 projects outwardly from the forward radial face 79 of the cover disk 63 of the receptacle insert around each of the openings 69. The bead 78 is engaged by the flat forward face 80 of the gasket 16 of the plug 9 when the connector is in the assembled position. Consequently, the bead 78 displaces the resilient material of the gasket 16 and an efficient moisture seal is produced. This type of seal does not rely upon the entry of a projecting part of the resilient elastomer into a recess in the hard plastic of the mating part as in some prior-art designs. Unlike the previous designs, swelling of the gasket 16 from attack of fluids will not appreciably interfere with the mating of the connector so that the axial force required will not vary significantly under those conditions.

The mechanism for securing the plug and receptacle together in the mated position includes a coupling ring 81 that circumscribes the plug shell 11. The rearward end of the coupling ring includes a radially inwardly extending flange 82 in back of a rearwardly facing shoulder 83 on the plug shell. A snap ring 84 fits in an annular recess 85 in the intermediate portion of the inner circumferential wall of the coupling ring 81. The snap ring 84 is positioned in front of a forwardly facing radial shoulder 86 on the plug shell 11, cooperating with the flange 82 in retaining the coupling ring 81 on the plug shell 11. This allows the coupling ring 81 to rotate relative to the plug shell 11, but relative axial movement is prevented.

Intermediate the snap ring 84 and the flange 82, the coupling ring 81 is provided with three short, arcuate, longitudinally extending recesses 87 in its inner surface 88 (see FIGS. 2 and 5). These recesses are adapted to receive the outer rounded portion 89 of a leaf spring 90. The latter member has normally straight legs 91 terminating in an inwardly bent end 92 which is received within a radial opening 93 in the periphery of the plug shell. This holds the spring 90 to the plug shell 11. Adjacent the legs 91 of the spring 90 are flat chordal surfaces 94 which provide a clearance for permitting flexure of the spring 90.

By this construction, the coupling ring 81 can be rotated relative to the plug shell 11, but there is a detent action tending to prevent relative rotation when the portion 89 of the spring 90 enters a recess 87. This re-

taining force may be overcome by applying adequate torque to the coupling ring to cam the rounded spring portion 89 out of the recess 87, compressing the spring inwardly and allowing the spring portion 89 to slide along the circumferential surface 88 of the coupling ring intermediate the recesses 87.

Forwardly of the snap ring 84, three bayonet grooves 95 are formed in the inner circumferential surface 88 of the coupling ring. Each groove 95 includes a wide entrance opening 96 at the forward end 97 of the coupling ring, from which there extends an inclined portion 98 of the groove, leading to a circumferential inner part 99 of the groove. The axis of the latter portion of the bayonet groove 95, as best seen in FIGS. 2 and 14, falls entirely within a radial plane as there is no recess for the bayonet pin at the inner end 100 of the groove.

The receptacle shell 65 includes a forward portion 101 of enlarged diameter which provides a clearance around the insert assembly 61. At the end of the forward portion 101 of the receptacle shell are three radially outwardly projecting bayonet pins 102.

When the electrical connector is to be mated, the forward end portion 103 of the plug shell 11 enters the forward portion 101 of the receptacle shell 65, fitting in the clearance space around the insert assembly 61 of the receptacle. Keys 104 on the plug shell fit in keyways 105 in the receptacle shell, assuring the proper rotational alignment of the plug and receptacle. With the keys in the keyways, the detent spring, when in a recess 87 in the coupling ring, positions the coupling ring so that the entrances 96 of the bayonet grooves 95 are aligned with the bayonet pins 102. Therefore, the bayonet pins 102 are brought to the entrances 96 of the bayonet grooves 95 in the coupling ring 81 as the plug and receptacle are advanced axially toward each other. Subsequent rotation of the coupling ring 81 moves the bayonet pins 102 through the inclined portions 98 of the grooves 95 and into the circumferential portions 99, drawing the plug and receptacle into the fully mated position. The coupling ring 81 is turned until the pins 102 are adjacent the inner ends 100 of the grooves 95, which occurs as the outer portion 89 of the spring 90 enters a detent recess 87 in the coupling ring.

A positive stop is provided in one of the bayonet grooves to prevent rotation of the coupling ring 81 past the detent position when the connector is mated. This is accomplished by bending inwardly a small section 106 of the circumferential wall of the coupling ring, presenting an abutment surface 107 in the bayonet groove where it can be contacted by the bayonet pin at the termination of the rotation of the coupling ring 81 (see FIG. 6). This location corresponds to the positioning of the outer portion 89 of the detent spring 90 in a detent receptacle 87. An opening 108 is formed in the wall of the coupling ring adjacent the stop 107, while two additional openings 109 in the coupling ring are spaced 120° from the opening 108. This permits visual exterior inspection of the connector when in the mated position to ascertain whether or not the bayonet pins 102 have moved a sufficient distance into the bayonet grooves 95. When the ends of the pins 102 (which may be painted) can be seen through the openings 108 and 109, it is known that the bayonet pins are in the inner portions of the bayonet slots and that the plug and receptacle are coupled properly.

By this arrangement, the plug and receptacle are advanced axially toward each other the maximum dis-

tance when the bayonet pins are adjacent the ends 100 of the grooves 95 that receive them. No outward movement occurs as the connection is made, and, when the bayonet pins 102 reach the circumferential portions 99 of the grooves 95, the parts are held in their position of full maximum engagement. Even though subjected to a separating force, no relative movement of the plug and receptacle can take place, so that electrical continuity through the contacts is assured. The bayonet pins 102 are held against the forward sides of the bayonet grooves 95 when separating forces are imposed, while the coupling ring 81 is prevented from movement axially by the engagement of the flange 82 with the rearwardly facing shoulder 83 of the plug shell 11. This provides a solid connection of the parts.

When the connector is in the fully mated position, the forward outer periphery of the forward end of the plug shell 11 engages an annular seal 110. The latter member is held in an annular groove 111 in the receptacle shell 65 by bonding.

In some instances, the snap ring 84 may be provided with forwardly projecting tabs 113 that are brought into engagement with the end of the forward portion 101 of the receptacle shell 65 when the connector is mated (see FIG. 15). This puts a desirable tension on the coupled plug and receptacle, eliminating any clearance in the coupling mechanism. This also makes an electrical connection between the plug shell 11 and the receptacle shell 65.

The plug and receptacle are disconnected by reverse rotation of the coupling ring 81 to free the bayonet pins 102 from the bayonet grooves 95. As this is accomplished, the detent spring 90 is forced out of one detent recess 87, and its central part 89 slides along the surface 88 of the coupling ring 81 to the next detent recess 87. In the latter detent position, the bayonet pins 102 have reached the entrances 96 to the grooves 95 and the plug and receptacle may be pulled apart axially.

The foregoing detailed description is to be clearly understood as given by way of illustration and example only, the spirit and scope of this invention being limited solely by the appended claims.

I claim:

1. An electrical connector device comprising an annular shell,
 - an insert of dielectric material received in said shell, said insert having a plurality of openings there-through,
 - a contact in each of said openings for engaging a mating contact and completing an electrical circuit, and means for retaining said insert in said shell, said retaining means including two longitudinally spaced opposed inwardly directed fixed abutments on the inner surface of said shell, and at least one outwardly projecting element on said insert,
 - said element being positioned between said abutments,
 - said element having opposite edges spaced longitudinally of said insert a distance substantially equal to the distance between said abutments, whereby said insert is retained by said shell and held against substantial longitudinal movement relative thereto,
 - the first of said abutments extending for a limited distance circumferentially of said shell for providing a space adjacent said first abutment,

said element extending for a limited distance circumferentially of said insert,

whereby, for assembly of said shell and said insert, said insert is movable longitudinally relative to said shell to move said element past said first abutment so that, upon subsequent relative rotation of said insert and said shell, said element is so positioned between said abutments,

said element including a portion extending from one of said edges and away from the other of said edges longitudinally relative to said shell so as to provide an additional edge engaging the side of said first abutment for limiting the rotational movement of said insert upon said positioning of said element between said abutments.

2. An electrical connector device comprising an annular shell,

an insert of dielectric material received in said shell, said insert having a plurality of openings there-through,

a contact in each of said openings for engaging a mating contact and completing an electrical circuit, and means for retaining said insert in said shell,

said retaining means including two opposed inwardly directed abutments on the inner surface of said shell,

the first of said abutments being defined by a plurality of laterally spaced portions on said shell, the second of said abutments being an annular shoulder,

a plurality of outwardly extending elements on said insert positioned between said first and second abutments for retaining said insert in said shell, said elements having a circumferential dimension no greater than the distance between adjacent surfaces of said portions of said first abutment for permitting said insert to be installed in said shell by moving said elements through said spaces between said portions of said first abutment, and subsequently rotating said insert to position said elements between said portions of said first abutment and said annular shoulder, and means bonding said insert to said shell for rotationally securing said insert to said shell for preventing said insert from rotating so as to remove said element from its position between said abutments.

3. An electrical connector device comprising a tubu-

lar cylindrical shell having a forward end and a rearward end,

an insert of dielectric material received in said shell, said insert having a forward end and a rearward end and a plurality of openings extending there-through between said forward end and said rearward end of said insert,

an electrical contact in each of said openings, and means for retaining said insert in said shell,

said retaining means including an annular radially inwardly directed forwardly facing fixed shoulder adjacent said rearward end of said shell,

said shoulder falling in a radial plane,

said shell having a plurality of spaced longitudinal slots in the inner circumferential wall thereof extending inwardly from said forward end of said shell,

said slots being interconnected by circumferential recesses adjacent said shoulder for thereby defining a plurality of rearwardly facing fixed abutments opposite said shoulder,

said abutments falling in a single radial plane and having ends extending to said slots,

a plurality of elements on said insert extending circumferentially and radially outwardly adjacent said rearward end of said insert,

said elements being positioned between said forwardly facing shoulder and said rearwardly facing abutments,

each of said elements having a forward edge adjacent one of said abutments and a rearward edge adjacent said shoulder,

said edges being in radial planes and spaced apart a distance substantially equal to the distance between said adjacent abutment and shoulder for preventing relative axial movement of said insert and said shell,

said elements having circumferential dimensions no greater than the widths of said slots for permitting them to be slid through said slots to said forwardly facing shoulder upon assembly of said insert and shell so that upon subsequent relative rotation of said insert and said shell said elements are so positioned between said forwardly facing shoulder and said abutments, and means for preventing substantial rotation of said insert relative to said shell.

* * * * *

50

55

60

65