

(No Model.)

J. WALKER.
MOLD FOR CASTING.

No. 343,872.

Patented June 15, 1886.

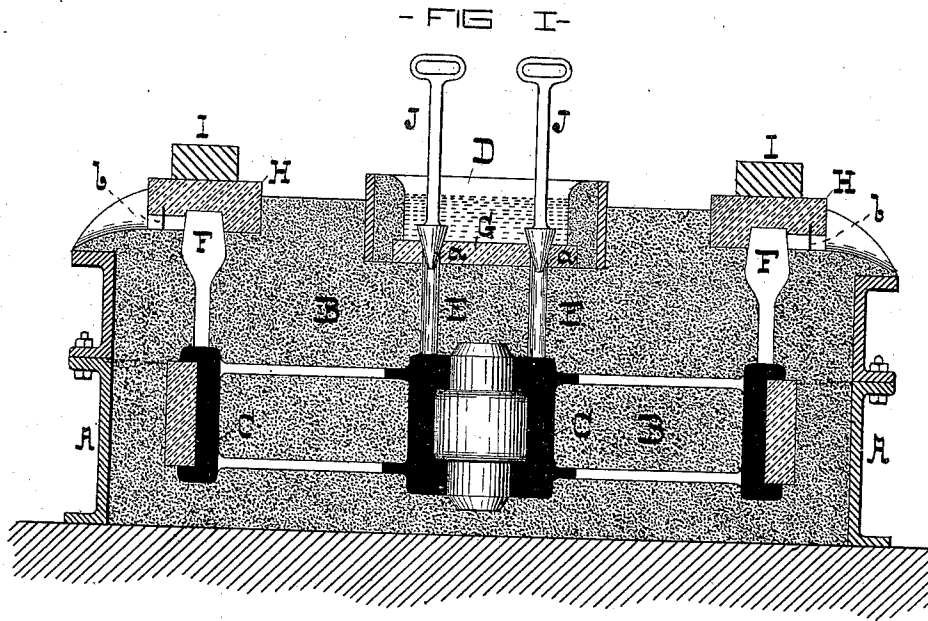

- FIG III -

- FIG II -

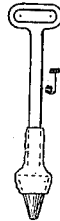
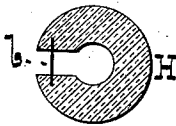

-WITNESSES-

Dan'l Fisher

Thomas S. Price

-INVENTOR-

John Walker,
by G. W. Howard,
attys -

UNITED STATES PATENT OFFICE.

JOHN WALKER, OF CLEVELAND, OHIO.

MOLD FOR CASTING.

SPECIFICATION forming part of Letters Patent No. 343,872, dated June 15, 1886.

Application filed March 9, 1886. Serial No. 194,542. (No model.)

To all whom it may concern:

Be it known that I, JOHN WALKER, of the city of Cleveland, in the county of Cuyahoga and State of Ohio, have invented certain
5 Improvements in the Art of Making Metal Castings, of which the following is a specification.

The first part of my said invention consists in facing the upper surface of that part
10 of the green-sand mold through which the gates are formed with a dried core-sand plate having openings in it which correspond in position with the said gates and constitute
15 the said plate removable stoppers or pods, which serve to close the said gates until the molten metal in the runner has risen to the desired height, when they are removed to admit the metal from below its dross and
20 slag covered surface to the mold. By this means only clean metal is allowed to flow to the mold, and all danger of sand from the upper edges of the gates being carried to the interior of the mold obviated.

25 The second part of my said invention consists in the application to the risers of covering-caps formed of dried core-sand, having outlet-apertures which are closed by sheets of metal which will fuse at a lower temperature than that of the metal poured into the
30 mold. These caps serve to keep the molten metal under a pressure until the metal rises into the caps and melts the fusible plates.

In the further description of my said invention which follows reference is made to the accompanying drawings, forming a part
35 hereof, and in which—

Figure I is a sectional view of a completed mold for a gear-wheel embodying my improvements. Figs. II and III are details of
40 the mold, as hereinafter described.

A represents the flask, and B the green-sand portion of the mold. The cavity in the sand to be filled with metal to form the casting is denoted by C.

45 D is the runner, into which the molten metal is poured, and E E are gates extending from the runner to the hub part of the mold.

F F are risers through which the molten

metal rises from the surface of the mold in 50 the pouring operation.

G is a plate of dried core-sand placed over the gates, having holes *a* corresponding in size and relative position with the gates, the
55 mouths of which they form. This dried-sand plate is sufficiently hard to resist the wearing action of the molten metal in pouring; consequently no sand is carried with the metal to the interior of the mold, as is often the case when green sand only is used. 60

H H are the riser-caps, which consist of blocks of dried core-sand having lateral discharge-openings in which are placed closing-plates *b* of fusible metal, preferably sheet-lead. The riser-caps are held down by weights
65 I, to prevent the caps being forced off by the air issuing from the risers, and to keep the molten metal under pressure until the completion of the pouring operation.

J J are pods to close the gates while the
70 runner is filling with molten metal.

The mold being prepared, as shown in Fig. I, metal is poured into the runner until it is nearly filled, as shown by the dotted lines, when the pods are removed and the pouring
75 continued. The gates being supplied from the lower portion of the metal in the runner, no slag, dross, or other foreign matter can enter the gates, as such matter, being lighter than the metal, remains on the surface. After
80 the mold is filled the surplus metal passing upward in the risers melts the lead plates and overflows, when the pouring is discontinued.

Fig. II is a sectional plan of one of the riser-
85 caps, showing the lead plate.

Fig. III is a view of one of the pods after its withdrawal from the runner. It will be seen that a portion of its surface is covered with iron; but this can be easily broken off
90 when cool.

I do not limit myself to the construction of the plate C and the riser-caps H of dried sand, as they could be formed of brick or other non-heat-conducting substance, if desired. 95

I claim as my invention—

1. In combination with a mold having a gate and a runner, a hardened plate with a

hole corresponding in position with the said gate, or directly over it, interposed between the said runner and gate, and a pod adapted to close the hole in the said plate, substantially as and for the purpose specified.

5 2. In combination with a mold having a riser therein, a cap to fit over the said riser

with an outlet-passage, and a fusible plate inserted in the said passage, substantially as and for the purpose specified.

JOHN WALKER.

Witnesses:

WM. G. TAYLOR,

M. Y. HUTTON.