

(21) Application No 8720744.5

(22) Date of filing 03.09.1987

(71) Applicant
Johnson Electric Industrial Manufactory Limited

(Incorporated in Hong Kong)

**Johnson Building, 14-16 Lee Chung Street, Chaiwan,
Hong Kong**

(72) Inventor
Roger Frederick Baines

(74) Agent and/or Address for Service
Marks & Clerk
57-60 Lincoln's Inn Fields, London, WC2A 3LS,
United Kingdom

(51) INT CL⁴
H02K 5/14

(52) UK CL (Edition J)
H2A AAB
U1S S2107

(56) Documents cited
GB 2183108 A GB 1333787 A GB 1149856 A

(58) Field of search
UK CL (Edition J) H2A
INT CL⁴ H02K

(54) **Brush gear for an electric motor**

(57) The motor is a permanent magnet direct current electric motor comprising a motor frame 10, 11, 12; an armature 18, 19, 22 supported for rotation in the motor frame; and a printed circuit 30 supported by the frame. The armature has a commutator 23, preferably a face plate commutator, and brush gear, in the form of precious metal brush leaves 32, is soldered directly to the printed circuit.

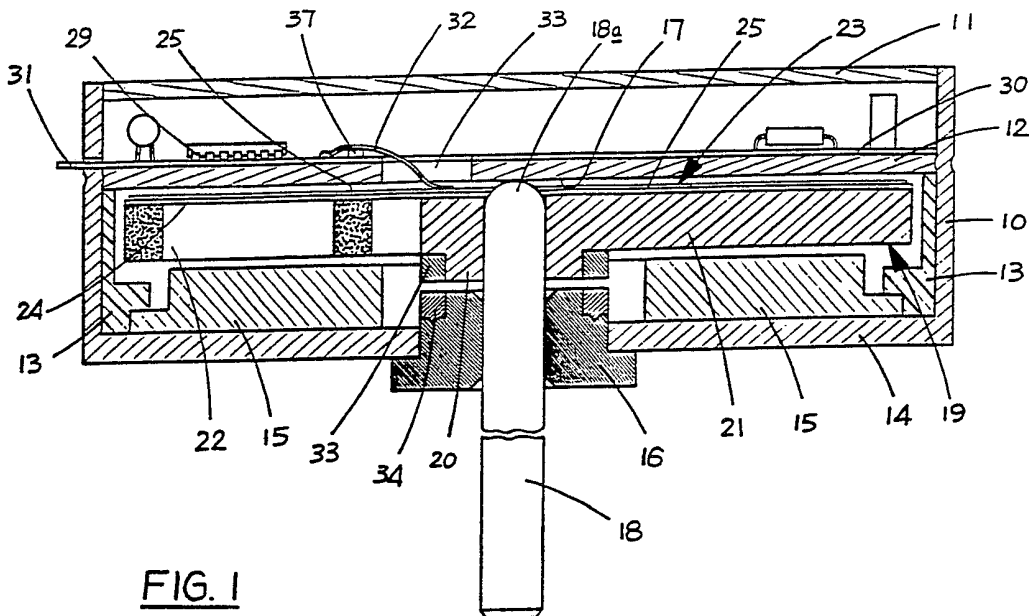

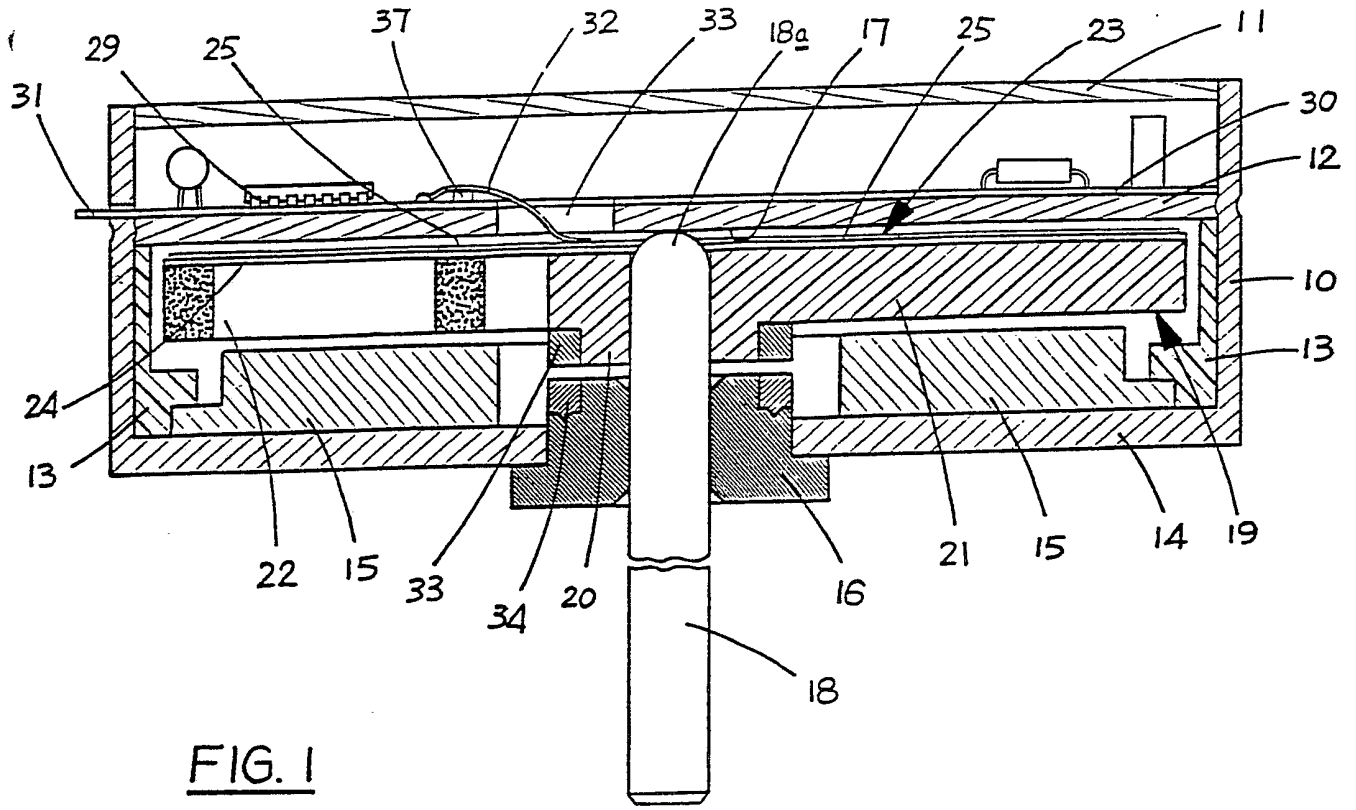

FIG. 1

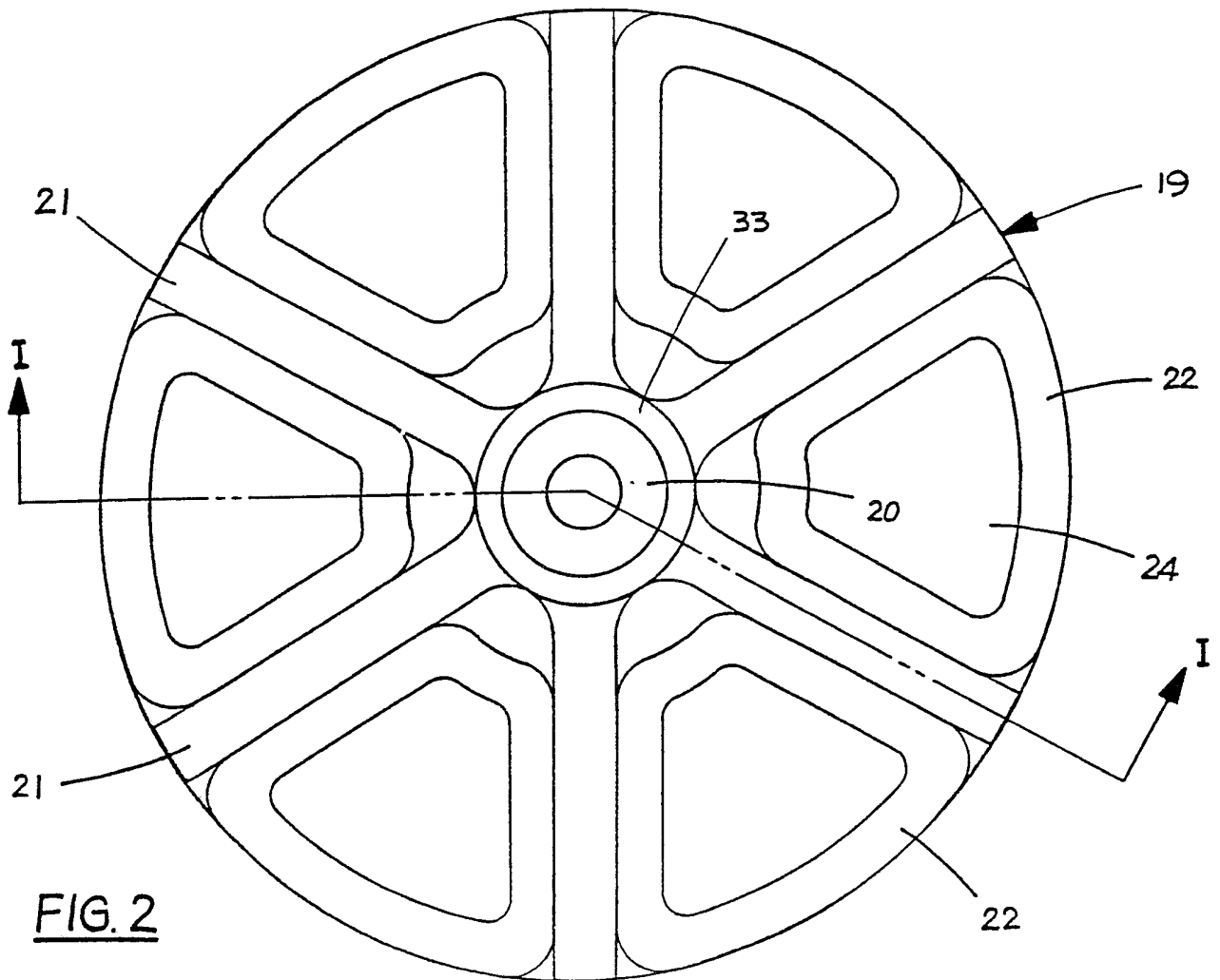

FIG. 2

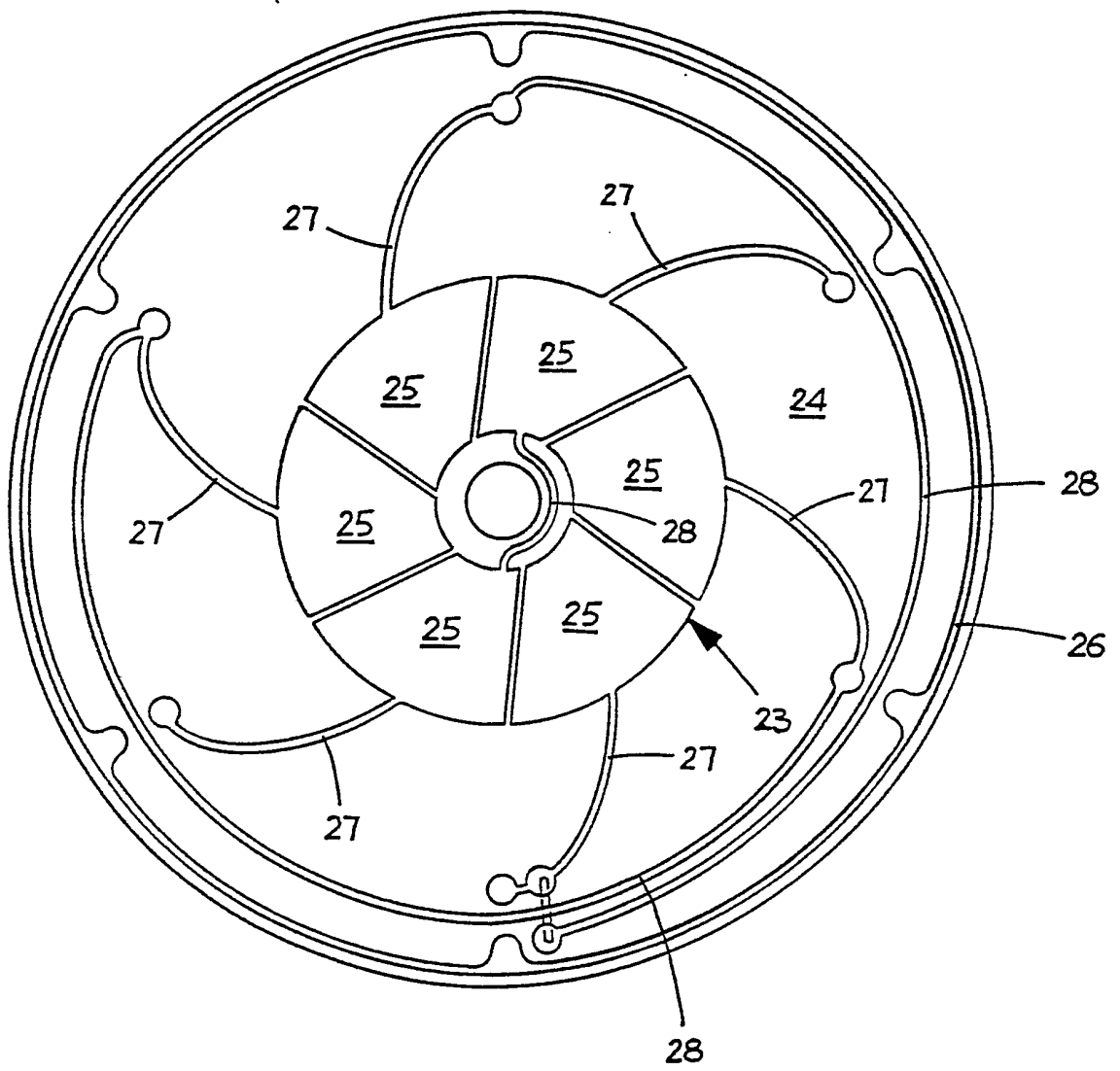

FIG. 3

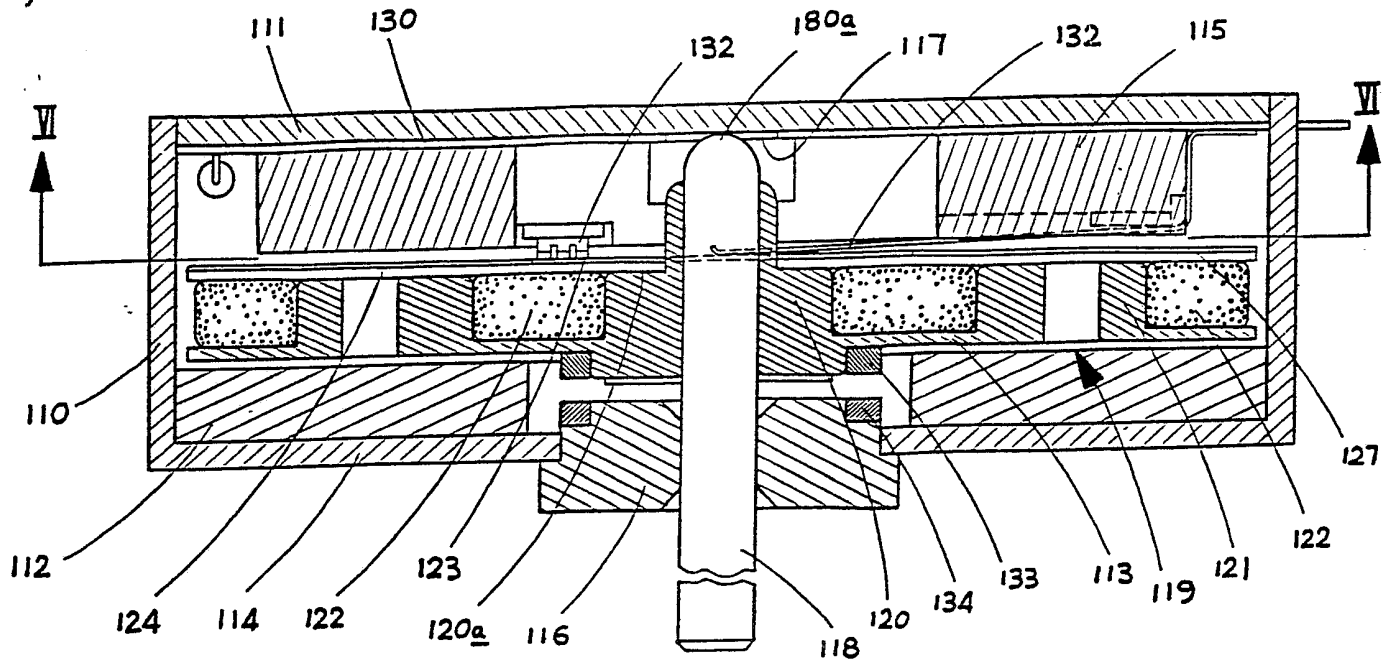

FIG. 4

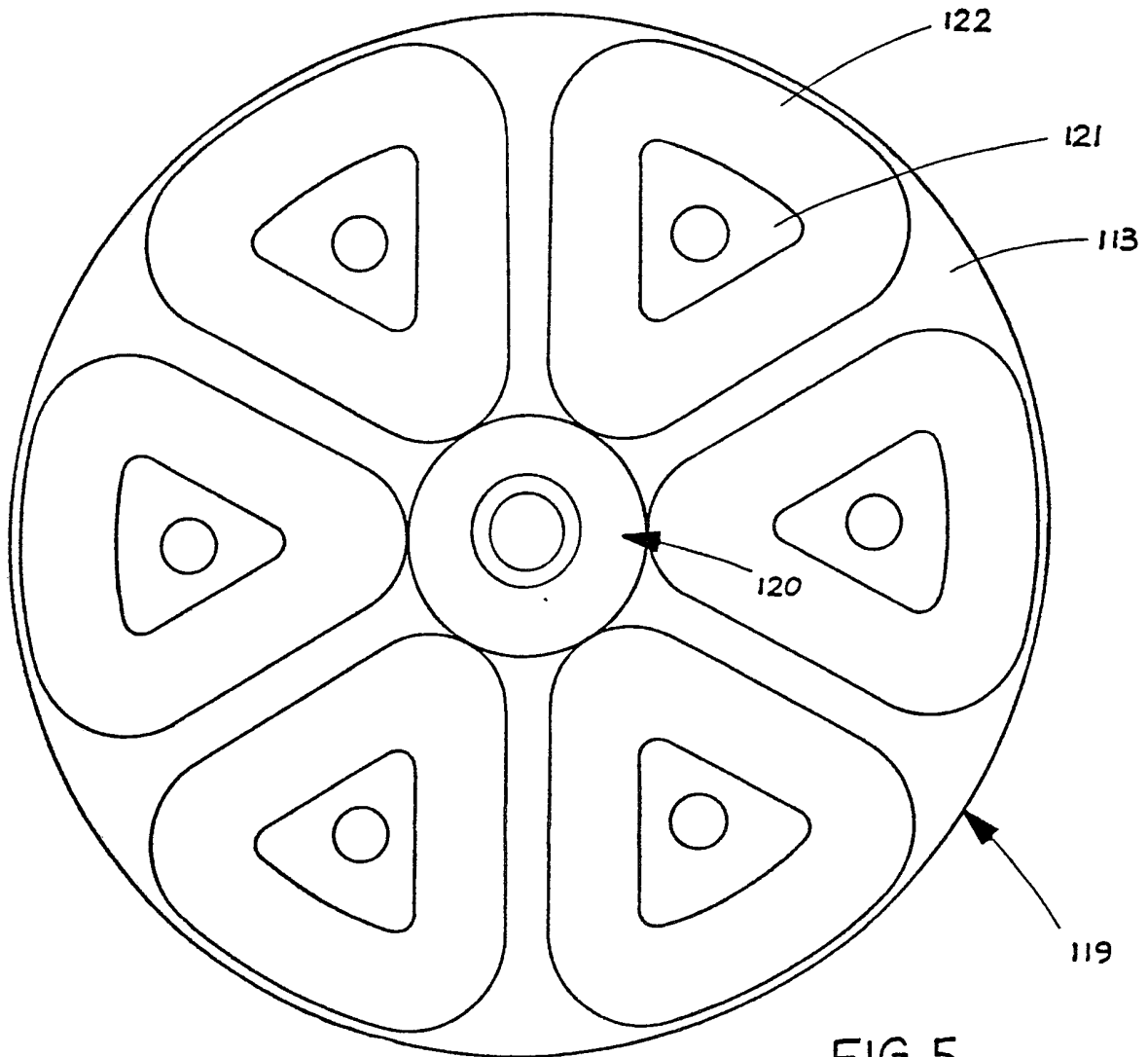

FIG. 5

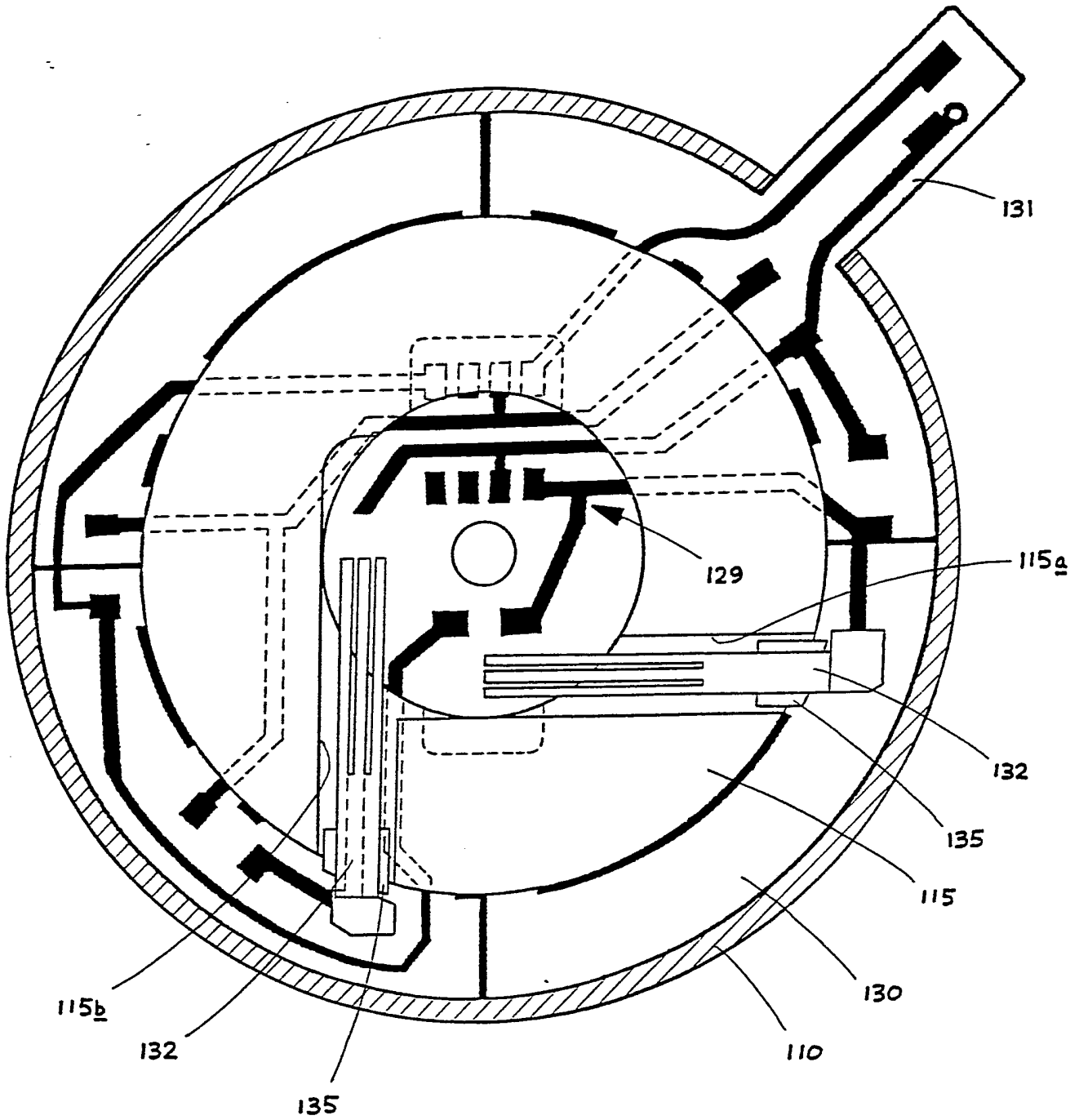

FIG. 6

An electric motor

This invention relates to a permanent magnet direct current electric motor and in particular to a fractional horsepower p.m.d.c. motor, such as may be used to drive audio equipment.

It is common to use printed circuits with electric motors and for example in a motor used to drive audio equipment, e.g. a tape player, it is common to use a printed circuit to mount the various electronic components which control the velocity of the motor.

According to the invention, there is provided a permanent magnet direct current electric motor, comprising a motor frame, an armature supported for rotation in the motor frame, the armature having a commutator, a printed circuit supported by or with respect to the motor frame and brush gear soldered directly to the printed circuit.

By mounting the brush gear in this way some connections in the circuit are eliminated thus minimising costs and reducing the number of elements likely to fail.

Furthermore, the geometry of the brush gear can be kept extremely simple to reduce wastage of material and simplify tooling. Also the geometry of the brush gear can be optimised for minimum energy storage so that the slip-stick effect of the interface with the commutator will not manifest as electrical noise in the system.

Preferred and/or optional features of the invention are set forth in claims 2 to 10.

The invention will now be more particularly described, by way of example, with reference to the accompanying drawings, in which:

Figure 1 is a sectional view of one embodiment of an electric motor according to the present invention, the section through the armature being taken along line I-I of Figure 2.

Figure 2 is an underneath plan view of the armature of Figure 1,

Figure 3 is a top plan view of the armature of Figure 1,

Figure 4 is a sectional view of another embodiment of an electric motor according to the invention,

Figure 5 is a top plan view of the armature of Figure 4 with the film bearing the commutator omitted, and

5 Figure 6 is a section taken along line VI-VI of Figure 4, with the electronics components omitted from the printed circuit film.

Referring first to Figures 1 to 3 of the drawings, the motor shown therein has a motor frame comprising a drawn
10 shallow metal can 10 closed by a metal end cap 11.

A plate 12 is provided within the can 10 and forms part of the motor frame. The plate 12 is located axially against a plastics sleeve 13 disposed within the can 10 and the plate 12 is secured in position by dimpling the
15 can from the outside to pinch and thus secure the plate 12 in position.

The inner surface of the base 14 of the can 10 supports four segmental permanent magnets 15. The magnets 15 are glued to the base 14 and adjacent magnets are magnetised
20 in opposite axial directions.

The magnets 15 are stepped at their outer circumferentially extending edges and these stepped edges are engaged by an annular, stepped, radially inwardly extending portion of the sleeve 13 to provide additional support for the magnets. The magnets could be replaced by a single annulus appropriately magnetised.

A radial bearing 16 is fixed in the base 14 of the can 10 and a thrust face 17 is provided on the inside of the plate 12.

A motor armature comprises a shaft 18 which is journalled in the radial bearing 16 and which has a part spherical non-driving end 18a bearing against the thrust face 17. The armature also comprises a plastics winding support 19 mounted fast on the shaft 18. The support 19 comprises a hub 20 and six radially extending spokes 21. Six discrete winding coils 22 are fixed between the spokes 21 of the support 19, such as by glue, and are equi-angularly spaced apart.

The hub 20 of the winding support 19 also defines a base for a commutator, conveniently a face plate commutator 23. The commutator 23 and the connections between the commutator 23 and the winding coils 22 are printed on a film 24 which is secured to the winding support 19, such as by glue. The film 24 is, conveniently, an epoxy resin or polyester based film clad with copper, etched, and subsequently masked in areas to which connections are not made. The commutator comprises six segments 25 arranged in a common plane and if desired these segments may be plated with noble metal. Typically, this would be achieved by plating the copper with nickel and then plating the nickel with noble metal. One end of each winding 22 is connected to a star point provided by conducting track 26 and the other end of each winding 22 is connected to a respective commutator segment 25 by respective conducting tracks 27. Diametrically opposed commutator segments 25 are electrically connected together by respective conducting tracks 28.

A speed regulating circuit 29 provided on a printed circuit film 30 is attached to the outer surface of the plate 12. Electrical terminations of the motor are printed on a tab 31 integral with the film 30 and

are led out of the can 10 through an opening in the side wall thereof.

Two resilient precious metal brush leaves 32 forming brush gear of the motor are soldered directly to the printed circuit film 30 and extend through holes 33 in the plate 12. The free end of each brush leaf 32 is forked and these ends of the brush leaves define brushes proper which make contact with the commutator at positions which are spaced apart geometrically by 90 degrees and, as considered electrically, at positions appropriate for optimum commutation. A small elastomeric pad 37 is interposed between each leaf 32 and the film 30 at a position close to the soldered connection to dampen vibration.

In the motor described above each winding coil is open circuited for a period as it passes across a pole face and during this period experiences no change in flux energy. This is particularly advantageous if the flux density across the pole face is substantially trapezoidal, which is likely if high energy magnets, such as neodymium iron boron magnets, are used.

In contrast, if the magnets are of a low energy content then the flux density across the pole faces will be sinusoidal and in that case it may be advantageous to connect the windings to form a parallel pair of delta windings so that each coil plays a continuous part in developing torque.

Coaxial ring magnets 33 and 34 are fitted on the hub 20 and on the radial bearing 16, respectively. The magnets 33 and 34 have their magnetic fields axially oriented with like poles adjacent so that the repulsion forces between the magnets urge the shaft 18 into contact with the thrust face 17.

The end cap 11 is secured to the can 10 by splayed lugs on the end cap 11 engaged in notches in the end of the can 10.

Referring now to Figures 4 to 6, the motor shown therein has a motor frame comprising a drawn shallow metal can 110 closed by a metal cover plate 111.

A mild steel keeper ring 112 is glued to the base 114 of the can 110.

A radial bearing 116 is fixed in the base 114 and a thrust face 117 is provided on the inside of the cover plate 111.

5 A motor armature comprises a shaft 118 which is journalled in the radial bearing 116 and which has a part spherical non-driving end 118a bearing against the thrust face 117. The armature also comprises a plastics winding support 119 mounted fast on the shaft 118. The support 119 comprises a hub 120, a
10 thin annular base 113 and six triangular, equi-angularly spaced bosses 121 upstanding from the base 113. Six discrete winding coils 122 are fixed about respective bosses 121, such as by glue.

A film 124, substantially identical to film 24
15 (Figure 3), has a face plate commutator 123 and connections 127 between the winding coils 122 printed thereon. The film 124, which may be self adhesive, is secured to the upper surface of each boss 121 and to a shoulder 120a provided on the hub 120 of the
20 winding support 119. Connections between the winding coils 122 and the segments of the commutator 123 are the same as described previously in connection with the embodiment shown in Figures 1 to 3.

A speed regulating circuit 129 provided on a printed circuit film 130 is attached to the inner surface of the cover plate 111. Electrical terminations of the motor are printed on a tab 131 integral with the film
5 130 and are led out of an opening in the side wall thereof or through the cover plate 111.

An annular magnet 115 appropriately magnetised to define a four pole magnetic field is secured to the printed circuit film 130, which may be self adhesive.

10 Cut outs 115a and 115b are provided in the side of the magnet 115 remote from the film 130 in order to accommodate two resilient precious metal brush leaves 132 which, as shown in Figure 7, are soldered directly to the printed circuit film 130. The free
15 end of each brush leaf 132 is forked and these ends of the brush leaves define brushes proper which make contact with the commutator at positions which are spaced apart geometrically by 90 degrees and, as considered electrically, at positions appropriate for
20 optimum commutation. A small elastomeric pad 140 is interposed between each leaf 132 and the magnet 115 at a position close to the soldered connection to dampen vibration.

Coaxial ring magnets 133 and 134 are fitted on the
hub 120 and on the radial bearing 116, respectively.
The magnets have their magnetic fields axially
oriented with like poles adjacent so that the
5 repulsion forces between the magnets urge the shaft
118 into contact with the thrust face 117.

The above embodiments are given by way of example
only and various modifications will be apparent to
persons skilled in the art without departing from the
10 scope of the invention defined by the appended claims.

Claims

1. A permanent magnet direct current electric motor, comprising a motor frame, an armature supported for rotation in the motor frame, the
5 armature having a commutator, a printed circuit supported by or with respect to the motor frame, and brush gear soldered directly to the printed circuit.

2. An electric motor as claimed in claim 1, wherein the brush gear comprises two precious metal
10 brush leaves.

3. An electric motor as claimed in claim 2, wherein the free end of each brush leaf is forked and bears against the commutator.

4. An electric motor as claimed in any one of
15 claims 1 to 3, wherein the commutator is a face plate commutator.

5. An electric motor as claimed in any one of the preceding claims, wherein vibration damping pads are interposed between the brush gear and the printed
20 circuit close to the soldered connections.

6. An electric motor as claimed in any one of the preceding claims, wherein the motor frame comprises a drawn can-like casing open at one end, an end cover closing the open end of the casing, and a plate fixed within the casing between the ends thereof, the printed circuit being supported by the plate.

7. An electric motor as claimed in any one of the preceding claims, wherein the motor frame comprises a drawn can-like casing open at one end and an end cover closing the open end of the casing, the printed circuit being supported by the end cover.

8. An electric motor as claimed in claim 7, wherein an annular magnet is secured to the printed circuit and the brush gear is accommodated in cut outs in the magnet.

9. An electric motor as claimed in any one of the preceding claims, wherein electrical terminations of the motor are printed on a tab integral with the printed circuit and are led out of the casing through an opening.

10. An electric motor as claimed in any one of the preceding claim, wherein a speed regulating circuit for the motor is provided on the printed circuit.

11. An electric motor as claimed in claim 1 and
5 substantially as hereinbefore described with reference to the accompanying drawings.

Amendments to the claims have been filed as follows

1. A permanent magnet direct current electric motor, comprising a motor frame, an armature supported for rotation in the motor frame, the armature having a commutator, a printed circuit supported by or with respect to the motor frame, and brush gear comprising two precious metal brush leaves soldered directly to the printed circuit.
5
- 10 2. An electric motor as claimed in claim 1, wherein the free end of each brush leaf is forked and bears against the commutator.
3. An electric motor as claimed in claim 1 or claim 2, wherein the commutator is a face plate commutator.
15
4. An electric motor as claimed in any one of the preceding claims, wherein vibration damping pads are interposed between the brush leaves and the printed circuit close to the soldered connections.

5. An electric motor as claimed in any one of the preceding claims, wherein the motor frame comprises a drawn can-like casing open at one end, an end cover closing the open end of the casing, and a plate fixed within the casing between the ends thereof, the printed circuit being supported by the plate.

6. An electric motor as claimed in any one of claims 1 to 4, wherein the motor frame comprises a drawn can-like casing open at one end and an end cover closing the open end of the casing, the printed circuit being supported by the end cover.

7. An electric motor as claimed in claim 6, wherein an annular magnet is secured to the printed circuit and the brush gear is accommodated in cut outs in the magnet.

8. An electric motor as claimed in any one of the preceding claims, wherein electrical terminations of the motor are printed on a tab integral with the printed circuit and are led out of the casing through an opening.

9. An electric motor as claimed in any one of the preceding claims, wherein a speed regulating circuit for the motor is provided on the printed circuit.

10. An electric motor substantially as hereinbefore
5 described with reference to the accompanying drawings.