

---

**(12) PATENT ABRIDGMENT (11) Document No. AU-B-17217/88**  
**(19) AUSTRALIAN PATENT OFFICE (10) Acceptance No. 605873**

---

(54) Title  
**APPARATUS AND METHOD FOR A NODE TO OBTAIN ACCESS TO A BUS**

International Patent Classification(s)  
(51)<sup>4</sup> **G06F 013/36**

(21) Application No. : **17217/88** (22) Application Date : **22.04.88**

(87) WIPO Number : **WO88/08579**

(30) Priority Data

(31) Number (32) Date (33) Country  
**044490 01.05.87 US UNITED STATES OF AMERICA**

(43) Publication Date : **02.12.88**

(44) Publication Date of Accepted Application : **24.01.91**

(71) Applicant(s)  
**DIGITAL EQUIPMENT CORPORATION**

(72) Inventor(s)  
**DARREL D. DONALDSON; RICHARD B. GILLET JR.**

(74) Attorney or Agent  
**GRIFFITH HACK & CO, GPO Box 1285K, MELBOURNE VIC 3001**

(57) Claim

1. A responder node coupled to a central arbiter by a commander request line, a responder request line, and a grant line corresponding exclusively to the responder node, wherein the central arbiter provides a conditional bus grant to a node generating a responder bus request prior to providing a conditional bus grant to a node generating a commander bus request, the node coupled to each of a plurality of other nodes by a shared extend bus cycle line and by a pended bus, wherein a node becomes a transmitter in order to transfer a message, including a command or including return data, on the pended bus during one or more cycles of the bus, wherein a commander node initiates a transaction on the pended bus by making a command transfer, wherein a responder node completes the transaction on the pended bus by making a return data transfer in response to the command transfer, and wherein a node can access the pended bus after the commander node initiates a transaction and before the responder node completes the transaction, the responder node comprising:  
responder bus request means, coupled to the responder request line, for generating a responder bus

(11) AU-B-17217/88  
(10) 605873

-2-

request and synchronously transmitting the responder bus request on the responder request line at times when return data is to be transferred from the responder node onto the bus;

extend request means for generating an extend request for the responder node at times when the responder node requires more than one bus cycle to transfer a message;

extend cycle means, coupled to the extend request means and to the extend bus cycle line, for activating an extend bus cycle signal on the extend bus cycle line when the responder node becomes a transmitter at times when the extend request for the responder node is present; and

bus access means, coupled to the grant line and to the extend bus cycle line, for obtaining control of the pended bus to enable the responder node to become a transmitter during an initial access cycle, in response to receipt of a conditional bus grant on the grant line, at times when an extend bus cycle signal is not activated on the extend bus cycle line by any of the other nodes, and for maintaining control of the pended bus to enable the responder node to remain the transmitter during bus cycles succeeding the initial access cycle at times when the extend bus cycle signal is activated by the responder node.

16. A method by which a node obtains access to a pended bus, wherein the node is coupled to a central arbiter by a commander request line, a responder request line, and a grant line corresponding exclusively to the node, wherein the central arbiter provides a conditional bus grant to a node generating a responder bus request prior to providing a conditional bus grant to a node generating a commander bus request, wherein the node is coupled to each of a plurality of other nodes by a shared extend bus cycle line and by the pended bus, wherein a node becomes a transmitter in order to transfer a message, including a command or including return data, on the pended bus during one or more cycles of the bus, wherein a

.../3

(11) AU-B-17217/88  
(10) 605873

-3-

commander node initiates a transaction on the pended bus by making a command transfer, wherein a responder node completes the transaction on the pended bus by making a return data transfer in response to the command transfer, and wherein a node can access the pended bus after the commander node initiates a transaction and before the responder node completes the transaction, the method comprising the steps of:

generating a commander bus request and synchronously transmitting the commander bus request on the commander request line at times when a command is to be transferred from the node onto the bus;

generating a responder bus request and synchronously transmitting the responder bus request on the responder request line at times when return data is to be transferred from the node onto the bus;

generating an extend request for the node at times when the node requires more than one bus cycle to transfer a message;

activating an extend bus cycle signal on the extend bus cycle line when the node becomes a transmitter at times when the extend request for the node is present;

obtaining control of the pended bus during an initial access cycle, in response to receipt of a conditional bus grant on the grant line, at times when an extend bus cycle signal is not activated on the extend bus cycle line by any of the other nodes; and

maintaining control of the pended bus during bus cycles succeeding the initial access cycle at times when the extend bus cycle signal is activated by the node.



605873

## INTERNATIONAL APPLICATION PUBLISHED UNDER THE PATENT COOPERATION TREATY (PCT)

<b>(51) International Patent Classification<sup>4</sup> :</b>  <b>G06F 13/36</b>	<b>A1</b>	<b>(11) International Publication Number: WO 88/ 08579</b>  <b>(43) International Publication Date: 3 November 1988 (03.11.88)</b>
<b>(21) International Application Number:</b> PCT/US88/01358 <b>(22) International Filing Date:</b> 22 April 1988 (22.04.88) <b>(31) Priority Application Number:</b> 044,490 <b>(32) Priority Date:</b> 1 May 1987 (01.05.87) <b>(33) Priority Country:</b> US <b>(71) Applicant:</b> DIGITAL EQUIPMENT CORPORATION [US/US]; 146 Main Street, Maynard, MA 01754 (US). <b>(72) Inventors:</b> DONALDSON, Darrel, D. ; 119 Old Common Road, Lancaster, MA 01523 (US). GILLET, Richard, B., Jr. ; 315 Pine Hill Road, Westford, MA 01886 (US). <b>(74) Agents:</b> GARRETT, Arthur, S.; Finnegan, Henderson, Farabow, Garrett & Dunner, 1775 K Street, N.W., Washington, DC 20006 (US) et al.	<b>(81) Designated States:</b> AT (European patent), AU, BE (European patent), CH (European patent), DE (European patent), FR (European patent), GB (European patent), IT (European patent), JP, KR, LU (European patent), NL (European patent), SE (European patent).  <b>Published</b> <i>With international search report.  Before the expiration of the time limit for amending the claims and to be republished in the event of the receipt of amendments.</i>  <b>A. O. J. P. 5 JAN 1989</b>  <div style="border: 1px solid black; padding: 5px; text-align: center;"> <b>AUSTRALIAN  - 2 DEC 1988  PATENT OFFICE</b> </div> <div style="border: 1px solid black; padding: 5px; text-align: center;"> This document contains the amendments made under section 49 and is correct for printing. </div>	
<b>(54) Title:</b> APPARATUS AND METHOD FOR A NODE TO OBTAIN ACCESS TO A BUS		
<b>(57) Abstract</b>  A node for obtaining access to a bus. In this arbitration method, the node receives a conditional grant. The node determines whether access to the bus will actually transfer to it. The node contains distributed logic that examines an extend bus cycle signal to determine whether it can become a transmitter to transfer messages on the bus. When the node becomes a transmitter, it generates an extend bus cycle signal to maintain access to the bus when executing a multi-cycle transfer, even though other nodes, perhaps with higher priorities, require access to the bus.		

APPARATUS AND METHOD FOR A NODE TO  
OBTAIN ACCESS TO A BUS  
FIELD OF THE INVENTION

The invention relates to a method and structure for arbitrating access to a bus in a computer system.

BACKGROUND OF THE INVENTION

A computer system can include a number of separate resources, such as processors, memories, and I/O devices, in order to perform various tasks. During operation of the computer system, it is often necessary for commands and/or data to be transferred between different resources in the computer system. Typically, a system bus is provided for transferring messages between a number of resources, or nodes, in a multiple node network.

In order to effectively utilize a common system bus for transfer of messages between resources, access to the bus by each of the resources must be carefully controlled. In particular, only one resource can attempt to transfer messages onto the system bus at any one time. For example, one resource may be ready to send out a read command during a particular bus cycle, while at the same time another resource is ready to obtain access to the bus for several bus cycles in order to transmit a write command and write data.

Therefore, in every computer system including a number of nodes coupled to a common bus, some form of "arbitration" must be performed in order to determine which node obtains access to the bus. A central arbiter can be coupled to each of the bus system resources and can determine which resource will be granted access to the bus during any given bus cycle. Such a central arbiter receives separate bus requests from each of the resources at times when that resource is ready to obtain access to the bus in order to transmit a message to another resource. In response to a number of bus requests, the central arbiter sends a bus grant to only one of the requesting nodes in a predetermined manner corresponding to a priority assigned to each request.

The use of bus request signals results in more efficient utilization of the bus and the system resources. Bus access is granted to a node only when that resource is performing an operation that requires transmission of a message by that resource onto the bus.

Unfortunately, certain types of transfers from a resource to the bus cannot be completed within a single bus cycle. For example, write transfers require that the resource be given access to the bus for more than one bus cycle. The message transferred onto the bus during the first bus cycle (command cycle) of the write transfer will be a write command. During the next consecutive bus cycle, write data will be transferred onto the bus.

To accommodate such multicycle transfers, an arbitration method may be used in which a resource performing a multicycle transfer operation must transmit an activated extend bus cycle signal to the central arbiter. The central arbiter would then determine whether it has received an activated extend bus cycle signal before generating a bus grant for a selected node. In these systems, issuance of the bus grant is delayed while the central arbiter processes the activated extend bus cycle signal. If an extend bus cycle signal is activated, the central arbiter transmits the bus grant to the same resource that had access to the bus during the preceding bus cycle.

An important disadvantage exists in systems utilizing such an arbitration method. Resources in the computer system obtain access to the bus based solely on the presence of a bus grant from the central arbiter. Therefore, the performance of the system and the effective utilization of the common bus depends upon the speed with which the bus grant is transmitted to a selected resource. This arbitration method, however, requires a relatively long bus cycle time because the arbiter must wait for the receipt of the extend bus cycle signal before generating a new grant. For systems that use a single wired-OR extend bus cycle signal, this would delay the availability of the grant.

It would be undesirable, however, to solve this problem by adding additional extend bus cycle lines from the resources to the central arbiter to increase the speed at which the arbiter can determine if the previous owner of the bus should retain ownership for the next cycle. Such a solution would require the addition of several pins on the backplane to supply another interconnect from each resource to the arbiter, and such pins may not be available.

The present invention attempts to overcome some of the above disadvantages and problems.

SUMMARY OF THE INVENTION

According to the present invention there is  
5 provided a responder node coupled to a central arbiter by a commander request line, a responder request line, and a grant line corresponding exclusively to the responder node, wherein the central arbiter provides a conditional bus grant to a node generating a responder bus request  
10 prior to providing a conditional bus grant to a node generating a commander bus request, the node coupled to each of a plurality of other nodes by a shared extend bus cycle line and by a pended bus, wherein a node becomes a transmitter in order to transfer a message, including a  
15 command or including return data, on the pended bus during one or more cycles of the bus, wherein a commander node initiates a transaction on the pended bus by making a command transfer, wherein a responder node completes the transaction on the pended bus by making a return data  
20 transfer in response to the command transfer, and wherein a node can access the pended bus after the commander node initiates a transaction and before the responder node completes the transaction, the responder node comprising:  
responder bus request means, coupled to the  
25 responder request line, for generating a responder bus request and synchronously transmitting the responder bus request on the responder request line at times when return data is to be transferred from the responder node onto the bus;  
30 extend request means for generating an extend request for the responder node at times when the responder node requires more than one bus cycle to transfer a message;  
extend cycle means, coupled to the extend  
35 request means and to the extend bus cycle line, for



activating an extend bus cycle signal on the extend bus cycle line when the responder node becomes a transmitter at times when the extend request for the responder node is present; and

5 bus access means, coupled to the grant line and to the extend bus cycle line, for obtaining control of the pended bus to enable the responder node to become a transmitter during an initial access cycle, in response to receipt of a conditional bus grant on the grant line, at  
10 times when an extend bus cycle signal is not activated on the extend bus cycle line by any of the other nodes, and for maintaining control of the pended bus to enable the responder node to remain the transmitter during bus cycles succeeding the initial access cycle at times when the  
15 extend bus cycle signal is activated by the responder node.

The present invention further provides a responder node coupled to a commander request line, a responder request line, and a grant line corresponding  
20 exclusively to the responder node, and coupled to each of a plurality of other nodes by a pended bus, wherein a node becomes a transmitter in order to transfer a message, including a command or including return data, on the pended bus during one or more cycles of the bus, wherein a  
25 commander node initiates a transaction on the pended bus by making a command transfer, wherein a responder node completes the transaction on the pended bus by making a return data transfer in response to the command transfer, and wherein a node can access the pended bus after the  
30 commander node initiates a transaction and before the responder node completes the transaction, the responder node comprising:

35 responder bus request means, coupled to the responder request line, for generating a responder bus request and transmitting the responder bus request on the responder request line at times when return data is to be transferred from the responder node onto the bus;





extend request means for generating an extend request for the responder node at times when the responder node requires more than one bus cycle to transfer a message;

5 extend cycle means, coupled to the extend request means, for activating an extend bus cycle signal when the responder node becomes a transmitter at times when the extend request for the responder node is present; and

10 bus access means, coupled to the grant line, for obtaining control of the pended bus to enable the responder node to become a transmitter during an initial access cycle, in response to receipt of a conditional bus grant on the grant line, at times when an extend bus cycle signal is not activated by any of the other nodes, and for  
15 maintaining control of the pended bus to enable the responder node to remain the transmitter during bus cycles succeeding the initial access cycle at times when the extend bus cycle signal is activated by the responder  
20 node.

There is also provided a responder node coupled to a central arbiter by a commander request line, a responder request line, and a grant line corresponding exclusively to the responder node, and coupled to each of  
25 a plurality of other nodes by a shared extend bus cycle line and by a pended bus, wherein a node becomes a transmitter in order to transfer a message, including a command or including return data, on the pended bus during one or more cycles of the bus, wherein a commander node  
30 initiates a transaction on the pended bus by making a command transfer, wherein a responder node completes the transaction on the pended bus by making a return data transfer in response to the command transfer, and wherein a node can access the pended bus after the commander node  
35 initiates a transaction and before the responder node completes the transaction, the responder node comprising:  
responder bus request means, coupled to the



responder request line, for generating a responder bus request and synchronously transmitting the responder bus request on the responder request line at times when return data is to be transferred from the responder node onto the bus;

extend request means for generating an extend request for the responder node at times when the responder node requires more than one bus cycle to transfer a message;

extend cycle means, coupled to the extend request means and to the extend bus cycle line, for activating an extend bus cycle signal on the extend bus cycle line when the responder node becomes a transmitter at times when the extend request for the responder node is present; and

bus access means, coupled to the grant line and to the extend bus cycle line, for obtaining control of the pended bus to enable the responder node to become a transmitter during an initial access cycle, in response to receipt of a conditional bus grant on the grant line, at times when an extend bus cycle signal is not activated on the extend bus cycle line by any of the other nodes, and for maintaining control of the pended bus to enable the responder node to remain the transmitter during bus cycles succeeding the initial access cycle at times when the extend bus cycle signal is activated by the responder node.

The present invention further provides a method by which a responder node obtains access to a pended bus, wherein the responder node is coupled to a commander request line, a responder request line, and a grant line corresponding exclusively to the responder node, wherein the responder node is coupled to each of a plurality of other nodes by the pended bus, wherein a node becomes a transmitter in order to transfer a message, including a command or including return data, on the pended bus during one or more cycles of the bus, wherein a commander node



initiates a transaction on the pended bus by making a command transfer, wherein a responder node completes the transaction on the pended bus by making a return data transfer in response to the command transfer, and wherein  
5 a node can access the pended bus after the commander node initiates a transaction and before the responder node completes the transaction, the method comprising the steps of:

- 10 generating a responder bus request and transmitting the responder bus request on the responder request line at times when return data is to be transferred from the responder node onto the bus;
- 15 generating an extend request for the responder node at times when the responder node requires more than one bus cycle to transfer a message;
- activating an extend bus cycle signal when the responder node becomes a transmitter at times when the extend request for the responder node is present;
- 20 obtaining control of the pended bus during an initial access cycle, in response to receipt of a conditional bus grant on the grant line, at times when an extend bus cycle signal is not activated by any of the other nodes; and
- 25 maintaining control of the pended bus during bus cycles succeeding the initial access cycle at times when the extend bus cycle signal is activated by the responder node.

The present invention further provides a method by which a node obtains access to a pended bus, wherein  
30 the node is coupled to a central arbiter by a commander request line, a responder request line, and a grant line corresponding exclusively to the node, wherein the central arbiter provides a conditional bus grant to a node generating a responder bus request prior to providing a  
35 conditional bus grant to a node generating a commander bus request, wherein the node is coupled to each of a plurality of other nodes by a shared extend bus cycle line



and by the pended bus, wherein a node becomes a transmitter in order to transfer a message, including a command or including return data, on the pended bus during one or more cycles of the bus, wherein a commander node  
5 initiates a transaction on the pended bus by making a command transfer, wherein a responder node completes the transaction on the pended bus by making a return data transfer in response to the command transfer, and wherein a node can access the pended bus after the commander node  
10 initiates a transaction and before the responder node completes the transaction, the method comprising the steps of:

generating a commander bus request and  
synchronously transmitting the commander bus request on  
15 the commander request line at times when a command is to be transferred from the node onto the bus;

generating a responder bus request and  
synchronously transmitting the responder bus request on  
the responder request line at times when return data is to  
20 be transferred from the node onto the bus;

generating an extend request for the node at times when the node requires more than one bus cycle to transfer a message;

activating an extend bus cycle signal on the  
25 extend bus cycle line when the node becomes a transmitter at times when the extend request for the node is present;

obtaining control of the pended bus during an initial access cycle, in response to receipt of a conditional bus grant on the grant line, at times when an  
30 extend bus cycle signal is not activated on the extend bus cycle line by any of the other nodes; and

maintaining control of the pended bus during bus cycles succeeding the initial access cycle at times when the extend bus cycle signal is activated by the node.

35 The present invention further provides a commander node coupled to a commander request line, a responder request line, and a grant line corresponding



exclusively to the node, and coupled to each of a plurality of other nodes by a pended bus, wherein a node becomes a transmitter in order to transfer a message, including a command or including return data, on the pended bus during one or more cycles of the bus, wherein a commander node initiates a transaction on the pended bus by making a command transfer, wherein a responder node completes the transaction on the pended bus by making a return data transfer in response to the command transfer, and wherein a node can access the pended bus after the commander node initiates a transaction and before the responder node completes the transaction, the commander node comprising:

commander bus request means, coupled to the commander request line, for generating a commander bus request and transmitting the commander bus request on the commander request line at times when a command is to be transferred from the commander node onto the bus;

extend request means for generating an extend request for the commander node at times when the commander node requires more than one bus cycle to transfer a message;

extend cycle means, coupled to the extend request means, for activating an extend bus cycle signal when the commander node becomes a transmitter at times when the extend request for the commander node is present; and

bus access means, coupled to the grant line, for obtaining control of the pended bus to enable the commander node to become a transmitter during an initial access cycle, in response to receipt of a conditional bus grant on the grant line, at times when an extend bus cycle signal is not activated by any of the other nodes, and for maintaining control of the pended bus to enable the commander node to remain the transmitter during bus cycles succeeding the initial access cycle at times when the extend bus cycle signal is activated by the commander node.



The present invention further provides a commander node coupled to a central arbiter by a commander request line, a responder request line, and a grant line corresponding exclusively to the node, and coupled to each of a plurality of other nodes by a shared extend bus cycle line and by a pended bus, wherein a node becomes a transmitter in order to transfer a message, including a command or including return data, on the pended bus during one or more cycles of the bus, wherein a commander node initiates a transaction on the pended bus by making a command transfer, wherein a responder node completes the transaction on the pended bus by making a return data transfer in response to the command transfer, and wherein a node can access the pended bus after the commander node initiates a transaction and before the responder node completes the transaction, the commander node comprising:

commander bus request means, coupled to the commander request line, for generating a commander bus request and synchronously transmitting the commander bus request on the commander request line at times when a command is to be transferred from the commander node onto the bus;

extend request means for generating an extend request for the commander node at times when the commander node requires more than one bus cycle to transfer a message;

extend cycle means, coupled to the extend request means and to the extend bus cycle line, for activating an extend bus cycle signal on the extend bus cycle line when the commander node becomes a transmitter at times when the extend request for the commander node is present; and

bus access means, coupled to the grant line and to the extend bus cycle line, for obtaining control of the pended bus to enable the commander node to become a transmitter during an initial access cycle, in response to receipt of a conditional bus grant on the grant line, at



times when an extend bus cycle signal is not activated on the extend bus cycle line by any of the other nodes, and for maintaining control of the pended bus to enable the commander node to remain the transmitter during bus cycles  
5 succeeding the initial access cycle at times when the extend bus cycle signal is activated by the commander node.

The present invention further provides a commander node coupled to a central arbiter by a commander  
10 request line, a responder request line, and a grant line corresponding exclusively to the node, wherein the central arbiter provides a conditional bus grant to a node generating a responder bus request prior to providing a conditional bus grant to a node generating a commander bus  
15 request, the node coupled to each of a plurality of other nodes by a shared extend bus cycle line and by a pended bus, wherein a node becomes a transmitter in order to transfer a message, including a command or including return data, on the pended bus during one or more cycles  
20 of the bus, wherein a commander node initiates a transaction on the pended bus by making a command transfer, wherein a responder node completes the transaction on the pended bus by making a return data transfer in response to the command transfer, and wherein  
25 a node can access the pended bus after the commander node initiates a transaction and before the responder node completes the transaction, the commander node comprising:  
commander bus request means, coupled to the commander request line, for generating a commander bus  
30 request and synchronously transmitting the commander bus request on the commander request line at times when a command is to be transferred from the commander node onto the bus;

extend request means for generating an extend  
35 request for the commander node at times when the commander node requires more than one bus cycle to transfer a message;



extend cycle means, coupled to the extend request means and to the extend bus cycle line, for activating an extend bus cycle signal on the extend bus cycle line when the commander node becomes a transmitter at times when the extend request for the commander node is present; and

bus access means, coupled to the grant line and to the extend bus cycle line, for obtaining control of the pended bus to enable the commander node to become a transmitter during an initial access cycle, in response to receipt of a conditional bus grant on the grant line, at times when an extend bus cycle signal is not activated on the extend bus cycle line by any of the other nodes, and for maintaining control of the pended bus to enable the commander node to remain the transmitter during bus cycles succeeding the initial access cycle at times when the extend bus cycle signal is activated by the commander node.

The present invention further provides a method by which a commander node obtains access to a pended bus, wherein the commander node is coupled to a commander request line, a responder request line, and a grant line corresponding exclusively to the node, wherein the commander node is coupled to each of a plurality of other nodes by the pended bus, wherein a node becomes a transmitter in order to transfer a message, including a command or including return data, on the pended bus during one or more cycles of the bus, wherein a commander node initiates a transaction on the pended bus by making a command transfer, wherein a responder node completes the transaction on the pended bus by making a return data transfer in response to the command transfer, and wherein a node can access the pended bus after the commander node initiates a transaction and before the responder node completes the transaction, the method comprising the steps of:





generating a commander bus request and transmitting the commander bus request on the commander request line at times when a command is to be transferred from the commander node onto the bus;

5 generating a commander bus request for the commander node at times when the commander node requires more than one bus cycle to transfer a message;

activating an extend bus cycle signal when the commander node becomes a transmitter at times when the  
10 extend request for the commander node is present;

obtaining control of the pended bus during an initial access cycle, in response to receipt of a conditional bus grant on the grant line, at times when an extend bus cycle signal is not activated by any of the  
15 other nodes; and

maintaining control of the pended bus during bus cycles succeeding the initial access cycle at times when the extend bus cycle signal is activated by the commander node.

20 The present invention further provides a node, coupled to a plurality of request lines corresponding exclusively to the node, and coupled to each of a plurality of other nodes by a pended bus, wherein a node becomes a transmitter in order to transfer a message,  
25 including a command or including return data, on the pended bus during one or more cycles of the bus, wherein a commander node initiates a transaction on the pended bus by making a command transfer, wherein a responder node completes the transaction on the pended bus by making a  
30 return data transfer in response to the command transfer, and wherein a node can access the pended bus after the commander node initiates a transaction and before the responder node completes the transaction, the node comprising:

35 bus request means, coupled to the plurality of request lines corresponding exclusively to the node, for generating a bus request and transmitting the bus request



on one of the corresponding plurality of request lines at times when a command is to be transferred from the node onto the bus, and for generating a bus request and transmitting the bus request on another one of the  
5 corresponding plurality of request lines at times when return data is to be transferred from the node onto the bus;

extend request means for generating an extend request for the node at times when the node requires more  
10 than one bus cycle to transfer a message;

extend cycle means, coupled to the extend request means, for activating an extend bus cycle signal when the node becomes a transmitter at times when the extend request for the node is present; and

•••••  
•••••  
•••••  
•••••  
•••••

15 bus access means, for obtaining control of the pended bus to enable the node to become a transmitter during an initial access cycle, in response to receipt of a conditional bus grant, at times when an extend bus cycle signal is not activated by any of the other nodes, and for  
20 maintaining control of the pended bus to enable the node to remain the transmitter during bus cycles succeeding the initial access cycle at times when the extend bus cycle signal is activated by the node.

•••••  
•••••  
•••••  
•••••  
•••••

The present invention further provides a method  
25 by which a node obtains access to a pended bus, wherein the node is coupled to a commander request line, a responder request line, and a grant line corresponding exclusively to the node, wherein the node is coupled to each of a plurality of other nodes by the pended bus,  
30 wherein a node becomes a transmitter in order to transfer a message, including a command or including return data, on the pended bus during one or more cycles of the bus, wherein a commander node initiates a transaction on the pended bus by making a command transfer, wherein a  
35 responder node completes the transaction on the pended bus by making a return data transfer in response to the command transfer, and wherein a node can access the pended



bus after the commander node initiates a transaction and before the responder node completes the transaction, the method comprising the steps of:

generating a commander bus request and  
5 transmitting the commander bus request on the commander request line at times when a command is to be transferred from the node onto the bus;

generating a responder bus request and  
10 transmitting the responder bus request on the responder request line at times when return data is to be transferred from the node onto the bus;

generating an extend request for the node at times when the node requires more than one bus cycle to transfer a message;

15 activating an extend bus cycle signal when the node becomes a transmitter at times when the extend request for the node is present;

obtaining control of the pended bus during an initial access cycle, in response to receipt of a  
20 conditional bus grant on the grant line, at times when an extend bus cycle signal is not activated by any of the other nodes; and

maintaining control of the pended bus during bus cycles succeeding the initial access cycle at times when  
25 the extend bus cycle signal is activated by the node.

#### BRIEF DESCRIPTION OF THE DRAWINGS

Preferred embodiments of the present invention will hereafter be described, by way of example only, with reference to the accompanying drawings, in which:

30 Fig. 1 is a block diagram of a data processing system of a preferred embodiment;

Fig. 2 is a block diagram of a node in the data processing system of Fig. 1;

35 Fig. 3 is a timing diagram showing timing signals used in the data processing system of Fig. 1;

Fig. 4 is a block diagram of the data interface

MRS

in the node of Fig. 2;

Fig. 5 is a block diagram of the arbiter in the data processing system of Fig. 1;

Fig. 6 is a block diagram of portions of the data processing system in Fig. 1 showing the arbitration signals;

Fig. 7 is a schematic diagram of extend cycle circuitry in the system portions in Fig. 6;

Fig. 8 is a schematic diagram of enable circuitry in the system portions in Fig. 6;

Fig. 9 is a block diagram of the central arbiter shown in Figs. 5 and 6; and

Fig. 10 is a timing diagram showing bus request, conditional bus grant, system bus drive enable, extend request, and extend bus cycle signals activated during operation of the data processing system of Fig. 1.

DETAILED DESCRIPTION OF THE PREFERRED EMBODIMENTS

Reference will now be made in detail to a preferred embodiment of the invention, an example of which is illustrated in the accompanying drawings.

A. System Overview

Fig. 1 shows an example of a data processing system 20 which embodies the present invention. The heart of system 20 is a system bus 25 which is a synchronous bus that allows communication between several processors, memory subsystems, and I/O systems. Communications over system bus 25 occur synchronously using periodic bus cycles. A typical bus cycle time for system bus 25 is 64 nsec.

In Fig. 1, system bus 25 is coupled to two processors 31 and 35, a memory 39, one I/O interface 41 and one I/O unit 51. I/O unit 53, is coupled to system bus 25 by way of I/O bus 45 and I/O unit interface 41.

A central arbiter 28 is also connected to system bus 25 in the preferred embodiment of data processing system 20. Arbiter 28 provides certain timing and bus



arbitration signals directly to the other devices on system bus 25 and shares some signals with those devices.

The implementation shown in fig. 1 is one which is presently preferred and should not necessarily be interpreted as limiting the present invention. For example, I/O unit 53 could be coupled directly to system bus 25, and arbiter 28 need not operate in the manner described for the present invention.

In the nomenclature used to describe the present invention, processors 31 and 35, memory 39 and I/O interface 41, and I/O device 51 are all called nodes. A "node" is defined as a hardware device which connects to system bus 25. A typical node 60 is shown in greater detail in Fig. 2.

According to the nomenclature used to describe the present invention, the terms "signals" or "lines" are mainly used interchangeably to refer to the names of the physical wires. The terms "data" or "levels" are mainly used to refer to the values which the signals or lines can assume.

Nodes perform transfers with other nodes over system bus 25. A "transfer" is one or more contiguous cycles that share a common transmitter and common arbitration. For example, a read operation initiated by one node to obtain information from another node on system bus 25 requires a command transfer from the first to the second node followed by one or more return data transfers from the second node to the first node at some later time.



A "transaction" is defined as the complete logical task being performed on system bus 25 and can include more than one transfer. For example, a read operation consisting of a command transfer followed later by one or more return data transfers is one transaction. In the preferred embodiment of system bus 25, the permissible transactions support the transfer of different data lengths and include read, write (masked), interlock read, unlock write, and interrupt operations. The difference between an interlock read and a regular or noninterlock read is that an interlock read to a specific location retrieves information stored at that location and restricts access to the stored information by subsequent interlock read commands. Access restriction is performed by setting a lock mechanism. A subsequent unlock write command stores information in the specified location and restores access to the stored information by resetting the lock mechanism at that location. Thus, the interlock read/unlock write operations are a form of read-modify-write operation.

Since system bus 25 is a "pended" bus, it fosters efficient use of bus resources by allowing other nodes to use bus cycles which otherwise would have been wasted waiting for responses. In a pended bus, after one node initiates a transaction, other nodes can have access to the bus before that transaction is complete. Thus, the node initiating that transaction does not tie up the bus for the entire transaction time. This contrasts with a non-pended bus in which the bus is tied up for an entire transaction. For example in system bus 25, after a node initiates a read transaction and makes a command transfer, the node to which that command transfer is directed may not be able to return the requested data immediately. Cycles on bus 25 would then be available between the command transfer and the return data transfer of the read transaction. System bus 25 allows other nodes to use those cycles.

In using system bus 25, each of the nodes can assume different roles in order to effect the transfer of information. One of those roles is a "commander" which is defined as a node which has initiated a transaction currently in progress. For example, in a write or read operation, the commander is the node

that requested the write or read operation; it is not necessarily the node that sends or receives the data. In the preferred protocol for system bus 25, a node remains as the commander throughout an entire transaction even  
5 though another node may take ownership of the system bus 25 during certain cycles of the transaction. For example, although one node has control of system bus 25 during the transfer of data in response to the command transfer of a read transaction, that one node does not become the  
10 commander of the bus 25. Instead, this node is called a "responder".

A responder responds to the commander. For example, if a commander initiated a write operation to write data from node A to node B, node B would be the  
15 responder. In addition, in data processing system 20 a node can simultaneously be a commander and a responder.

Transmitters and receivers are roles which the nodes assume in an individual transfer. A "transmitter" is defined as a node which is the source of information placed on system bus 25 during a transfer. A "receiver" is the complement of the transmitter and is defined as the node which receives the information placed on system bus  
20 25 during a transfer. During a read transaction, for example, a commander can first be a transmitter during the command transfer and then a receiver during the return data transfer.

When a node connected to system bus 25 desires to become a transmitter on system bus 25, that node asserts one of two request lines, CMD REQ (commander request) and RES REQ (responder request), which are  
30 connected between central arbiter 28 and that particular node. The CMD REQ and RES REQ lines are shown generally in Fig. 1. In general, a node uses its CMD REQ line to request to become commander and initiate transactions on system bus 25, and a node uses its RES REQ line to become  
35 a responder to return data or message to a commander.



Generally, central arbiter 28 detects which nodes desire access to the bus (i.e., which request lines are asserted). The arbiter then responds to one of the asserted request lines to grant the corresponding node access to bus 25 according to a priority algorithm. In the preferred embodiment, arbiter 28 maintains two independent, circular queues: one for the commander requests and one for the responder requests. Preferably, the responder requests have a higher priority than the commander requests and are handled before the commander requests.

The commander request lines and responder request lines are considered to be arbitration signals. As illustrated in Fig. 1, and as will be explained in greater detail in the description of Fig. 6, arbitration signals also include point-to-point conditional grant signals from central arbiter 28 to each node, system bus extend signals to implement multi-bus cycle transfers, and system bus suppression signals to control the initiation of new bus transactions when, for example, a node such as memory is momentarily unable to keep up with traffic on the system bus.

Other types of signals which can constitute system bus 25 include information transfer signals, respond signals, control signals, console/front panel signals, and a few miscellaneous signals. Information transfer signals include data signals, function signals which represent the function being performed on the system bus 25 during a current cycle, identifier signals identifying the commander, and parity signals. The respond signals generally include acknowledge or confirmation signals from a receiver to notify the transmitter of the status of the data transfer.

Control signals include clock signals, warning signals, such as those identifying low line voltages or low DC voltages, reset signals used during initialization, node failure signals, default signals used during idle bus





cycles, and error default signals. The console/front panel signals include signals to transmit and receive serial data to a system console, boot signals to control the behavior of a boot processor during power-up, signals  
5 to enable modification of the erasable PROM of processors 31,35 on system bus 25, a signal to control a RUN LIGHT on the front panel, and signals providing battery power to clock logic on certain nodes. The miscellaneous signals, in addition to spare signals, include identification  
10 signals which allow each node to define its identification code.

Fig. 2 shows an example of a node 60 connected to system bus 25. Node 60 could be a processor, a memory, an I/O unit or an I/O interface, as shown in Fig. 1. In  
15 the example shown in Fig. 2, node 60

1  
2  
3  
4  
5

6  
7  
8  
9  
0

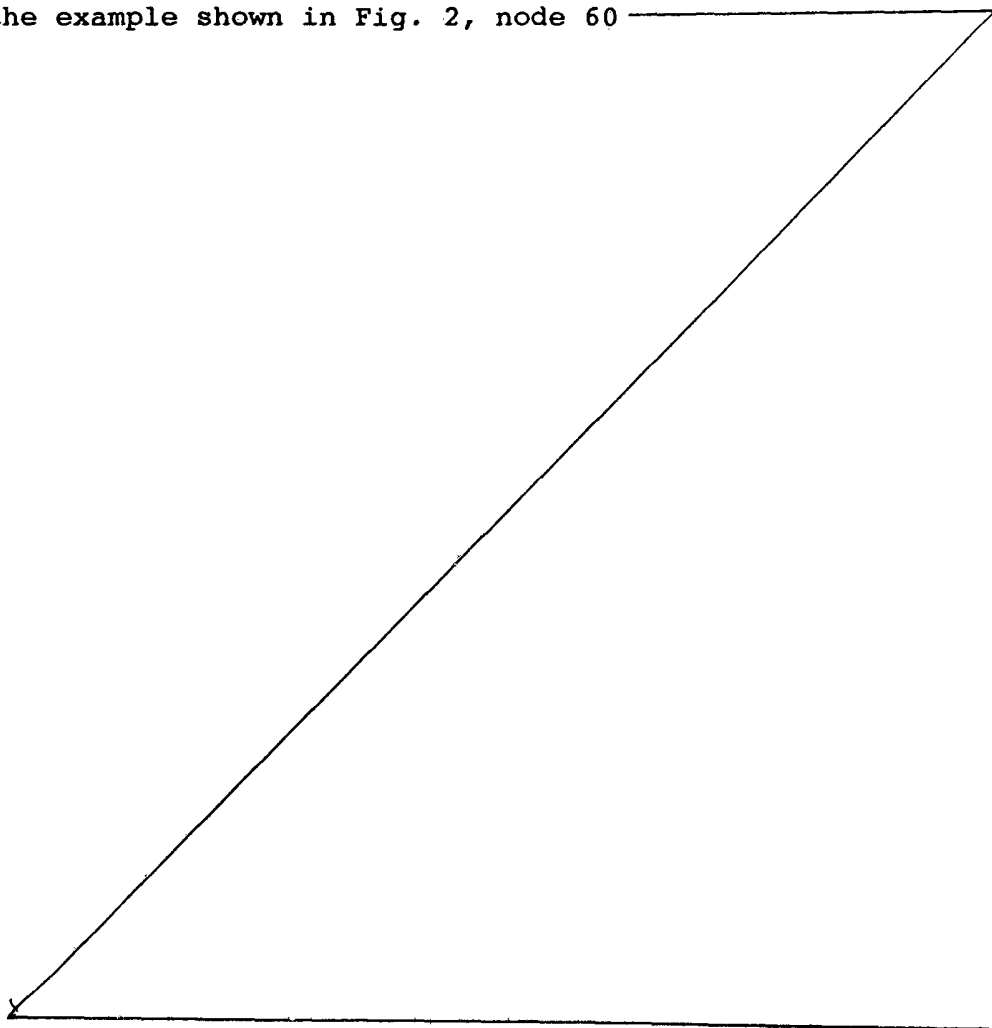

includes node specific logic 65, a node bus 67, and a system bus interface 64 containing a data interface 61 and a clock decoder 63. Preferably, data interface 61, clock decoder 63, and node bus 67 are standard elements for nodes connected to system bus 25. The node specific logic 65, which uses different integrated circuits from system bus interface 64, preferably includes, in addition to the circuitry designed by a user to carry out the specific function of a node, standard circuitry to interface with the node bus 67. In general, data interface 61 is the primary logical and electrical interface between node 60 and system bus 25, clock decoder 63 provides timing signals to node 60 based on centrally generated clock signals, and node bus 67 provides a high speed interface between data interface 61 and node specific logic 65.

In the preferred embodiment of node 60 and system bus interface 64 shown in Fig. 2, clock decoder 63 contains control circuitry for forming signals to be placed on system bus 25 and processes clock signals received from central arbiter 28 to obtain timing signals for node specific logic 65 and data interface 61. Since the timing signals obtained by clock decoder 63 use the centrally generated clock signals, node 60 will operate synchronously with system bus 25.

Fig. 3 is a timing diagram showing one bus cycle, the clock signals received by clock decoder 63, <sup>from central arbiter 28 (Fig. 1)</sup> and certain of the timing signals generated by clock decoder 63. The clock signals received by clock decoder 63 include a Time H signal, a Time L signal, and a Phase signal as shown in Fig. 3. Time H and Time L are inverses of the fundamental clock signals and the Phase signal is obtained by dividing the fundamental clock signal by three. The timing signals generated by clock decoder 63 include C12, C23, C34, C45, C56 and C61, all of which are shown in Fig. 3. Those timing signals required by data interface 61, which occur once per bus cycle, are provided to data interface 61, and a complete set of timing signals, including equivalent ones of the timing signals provided to data interface 61, is buffered and provided to the node specific logic 65. The purpose of buffering is to insure that node specific logic 65 cannot adversely affect the operation of the system bus interface 64 by



improperly loading the timing signals. Clock<sup>decoder</sup><sub>63</sub> uses the clock signals to create six subcycles for each bus cycle and then uses the subcycles to create the six timing signals CXY, where X and Y represent two adjacent subcycles which are combined to form one timing signal.

Each node in the ~~system~~<sup>system</sup> bus has its own corresponding set of timing signals generated by its clock decoder 63. While nominally the corresponding signals occur at exactly the same time in every node throughout the system<sup>20</sup>, variations between clock decoder 63 and other circuitry in multiple nodes introduce timing variations between corresponding signals. These timing variations are commonly known as "clock skew."

Fig. 4 shows a preferred embodiment of data interface 61. Data interface 61 contains both temporary storage circuitry and bus driver circuitry to provide a bidirectional and high speed interface between each of the lines of node bus 67 and each of the lines of system bus 25. As shown in Fig. 4, data interface 61 preferably includes storage elements 70 and 72 and system bus driver 74 to provide a communication path from node bus 67 to system bus 25. Data interface 61 also includes storage element 80 and node bus driver 82 to provide communication path from system bus 25 to node bus 67. As used in the description of data interface 61, the term "storage element" refers generally to bistable storage devices such as transparent latch or a master-slave storage element, and not to a specific implementation. Persons of ordinary skill will recognize which types of storage elements are appropriate.

As shown in Fig. 4, storage element 70 has an input connected to receive data from node bus 67 and an output connected to the input of storage element 72. The output of storage element 72 is connected to an input of system bus driver 74 whose output is connected to system bus 25. Storage elements 70 and 72 are controlled by node bus control signals 76 and 78, respectively, which are derived from the timing signals generated by clock decoder 63. Storage elements 70 and 72 provide a two-stage temporary storage for pipelining data from node bus 67 to system bus 25. Different numbers of storage stages can also be used.



System bus driver 74 is controlled by system bus drive enable 79. According to the state of the system bus drive enable 79, the input of system bus driver 74 either is coupled to its output, thereby transferring the data at the output of storage element 72 to system bus 25, or decoupled from that output. When system bus drive enable 79 decouples the input and output of the system bus driver 74, system bus driver 74 presents a high impedance to system bus 25. The system bus drive enable 79 is also generated by clock decoder 63 in accordance with clock signals received from system bus 25 and control signals received from the node specific logic 65.

Storage element 80 has an input terminal connected to system bus 25 and an output terminal connected to an input of node bus driver 82. The output of node bus driver 82 is connected back to node bus 67. Storage element 80, preferably a transparent latch, is controlled by a system bus control signal 85 which is derived from the timing signals generated by clock decoder 63. A node bus drive signal 87 controls node bus driver 82 similar to the manner in which system bus drive signal 79 controls system bus driver 74. Thus, in response to node bus drive signal 87, node bus driver 82 either couples its input to its output or decouples its input from its output and provides a high impedance to node bus 67.

In order to explain how data is transferred over system bus 25, it is important to understand the relationship between system bus drive enable 79 and control signal 85. In the present embodiment, this relationship is shown in Fig. 3. System bus drive enable 79 is nominally driven from the beginning to the end of a bus cycle. The new data become available for receipt from system bus 25 at some time later in the bus cycle after driver propagation and bus settling time has occurred. In the present embodiment, storage element 80 is a transparent latch. Control signal 85 is logically equivalent to clock C45. The bus timing assures that system bus 25 data is available for receipt sometime prior to the deassertion of control signal 85. Storage element 80 stores bus data that is stable at least a set-up time prior to the deassertion of control signal 85 and remains stable a hold time after the deassertion of control signal 85.



Node bus 67 is preferably a very high speed data bus which allows bidirectional data transfer between the node specific logic 65 and system bus 25 by way of data interface 61. In the preferred embodiment of node 60 shown in Fig. 2, node bus 67 is an interconnect system consisting of point-to-point connections between the system bus interface 64 and the node specific logic 65. In accordance with the present invention, however, there is no requirement for such point-to-point interconnection.

Fig. 5 shows a preferred embodiment of the central arbiter 28 which is also connected to system bus 25. Central arbiter 28 provides the clock signals for system bus 25 and grants ownership of the bus to the nodes on system bus 25. Central arbiter 28 preferably includes an arbitration circuit 90, a clock circuit 95, and a oscillator 97. Oscillator 97 generates the fundamental clock signals. Clock 95 provides timing signals for arbitration circuit 90 and the basic Time H, Time L, and Phase clock signals for timing on system bus 25.

Arbitration circuit 90 receives the commander and responder request signals, arbitrates conflicts between nodes desiring access to system bus 25, and maintains the queues referred to above for the commander and responder requests. Arbitration circuit 90 also provides certain control signals to clock 95.

B. Arbitration

In accordance with the invention, each of the nodes on a bus can obtain access to that bus in order to transfer messages to other nodes. The messages may take one or more bus cycles. At a given time, any or all of the nodes 60 may desire to perform transfers on the bus 25. In the present invention, the bus cycles used for arbitration can occur in parallel with the bus cycles used for transfer of data.

The nodes in the present invention include bus request means for generating a bus request at times when a message is to be transferred from the node onto the bus.



As embodied in Fig. 6, a CPU node 31 and an I/O device node 51 are both included in system 20, which also includes a plurality of other nodes (not shown). In one embodiment, CPU node 31 includes a command generator 110 within its node specific logic 65, and I/O device node 51 includes response generator 112 within its node specific logic (not shown).

At times when either node 31 or node 51 is ready to perform a transfer, they must output a bus request to arbiter 28 on their respective bus request lines. For example, at times when CPU node 31 needs to write data into another node in the system 20, command generator 110 will generate a (commander) bus request in order to request access to bus 25 for at least two consecutive bus cycles. As another example, when I/O device node 51 has previously generated an interrupt request and must transfer interrupt vector data to another node in response to the transfer of an interrupt acknowledge command by that other node, response generator 112 will generate a (responder) bus request. In the case of an interrupt vector message, I/O node 51 typically demands access to bus 25 for only a single bus cycle.

In the preferred embodiment, bus requests are sent from each of the nodes in the system 20 to arbiter 28 using a pair of dedicated lines. A commander request line, such as a CMD REQ 102 or 106, is used by a node to request access when the node is initiating new transactions, and a responder request line, such as RES REQ 104 and 108, is used by a node to return data to a commander, such as when a read command or an interrupt acknowledge command is received and serviced by a node. Preferably, a responder request has higher priority than a commander request.

As shown in Fig. 6 for the example discussed above, CPU 31 will generate a bus request on its dedicated commander request line 102, and I/O device 51 will generate a bus request on its dedicated responder request line 108. As discussed previously, each bus cycle in the



preferred embodiment is divided into six subcycles. In the present embodiment, the arbiter 28 samples bus requests from each of the nodes during subcycles 6 and 1 of each bus cycle, as shown in Fig. 10. In Fig. 10, the origin of the arrow indicates the approximate sample time of a signal, and the presence of an activated signal is determined by the voltage level at the origin of the arrow.

Returning to Fig. 6, in accordance with the present invention, extend request means are provided for generating an extend request for each of the nodes which require more than one bus cycle to transfer a message, and for maintaining this extend request during succeeding bus cycles. As embodied herein, if CPU 31 creates a write command in command generator 110, that command will require multiple bus cycles to complete the transfer of data. Command data is transferred during an initial access cycle, and write data is transferred during succeeding cycles. The initial access cycle is the first cycle in which system bus drive enable signal 79 is asserted for a transfer. Therefore, an extend request generator 111 will output an extend request on line 118 at the same time that command generator 110 is asserting commander request line 102, and will maintain this extend request on line 118 until the last bus cycle, during which transfer of data is completed.

In accordance with the invention, each of the nodes includes extend cycle means coupled to the extend request means for activating an extend bus cycle signal during the initial access cycle when the node becomes a transmitter, and for maintaining the extend bus cycle signal activated during succeeding bus cycles, at times when the extend request for the node is present. As embodied herein, the extend bus cycle signal (Fig. 10, signal E) is output on extend bus cycle line 120, which is coupled to the arbiter 23 and to each of the nodes in system 20. Preferably, CPU 31 includes extend cycle



circuitry 122 in clock decoder 63 for activating the extend bus cycle signal (Fig 10, signal E) on line 120 (Fig. 6) during the initial access bus cycle and succeeding bus cycles at times when the extend request on line 118 is present.

A node cannot activate the extend bus cycle signal if an extend bus cycle signal is currently activated by another node, or a conditional bus grant (Fig 10, signal B) has not been received. As shown in Fig. 6, extend cycle circuitry 122 in CPU 31 receives an extend request generated by extend request generator 111. Circuitry 122 then activates the extend bus cycle signal on extend bus cycle line 120 if the two conditions just described do not exist.

Each node in accordance with the invention includes receiving means for receiving a conditional bus grant from the arbiter and for receiving an extend bus cycle signal from the other nodes. When it is in an activated state, the extend bus cycle signal indicates that a node which is currently transmitting a message will continue to transfer the message during the next bus cycle. Each of the nodes includes enable circuitry 124 that is coupled to a common extend bus cycle line 120 in order to receive an extend bus cycle signal activated by any one of the nodes. Additionally, enable circuitry 124 for each node, which in the present embodiment is included in clock decoder 63, is coupled to arbiter 28 by a dedicated point-to-point conditional bus grant line corresponding to that node, such as lines 114 and 116. Arbiter 28 transmits a conditional bus grant to a selected node along one of these dedicated lines. For example, conditional grant lines 114 and 116 respectively couple CPU 31 and I/O device 51 to arbiter 28.

During any given bus cycle, arbiter 28 receives bus requests (Fig. 10, signal A) from a number of nodes 60 and determines which selected node 60 will be "conditionally" granted access to the bus 25. In the





present embodiment shown in Fig. 10, after arbiter 28 samples the bus requests (signal A) during subcycle 6 (in bus cycle 1) and subcycle 1 (in bus cycle 2), it transmits a conditional bus grant (signal B) to a selected node.

5 The conditional bus grant (signal B) is sampled by the selected node during subcycle 6 of the second bus cycle. If no extend bus cycle signal (signal E) is activated on extend bus cycle line 120 (Fig. 6) when sampled by the selected node during the second bus cycle, the node will  
10 become a transmitter and transfers its message to system bus 25 beginning with the third bus cycle. In this example, the node selected during the second cycle became a transmitter during the third cycle, and the third bus cycle is therefore the "initial access cycle" for that  
15 transmitter. If an extend bus cycle signal is activated on line 120 and sampled by enable circuitry 124 of the selected node during subcycles 4 and 5 of the second bus cycle, then the selected node is unable to obtain access to bus 25 during the next bus cycle, despite receiving a  
20 conditional bus grant during subcycle 6 of the second cycle.

Referring again to Fig. 6, in accordance with the invention, each of the nodes includes bus access means, coupled to the extend bus cycle means and  
25 responsive to the conditional bus grant, for generating a system bus drive enable signal in the selected node when no extend bus cycle signal is activated by another node which was the previous transmitter; and for maintaining the system bus drive enable signal level while the extend  
30 bus cycle signal for the selected transmitter node is activated. As embodied herein, enable circuitry 124 activates system bus drive enable signal 79 for driver 74, which is shown in Fig. 4 as contained in data interface circuitry 61. At times when driver 74 is enabled by an  
35 activated system bus drive enable signal 79, a message can be transferred onto system bus 25 from the node.



The preferred embodiment of a means for activating an extend bus cycle signal is shown in Fig. 7. For purposes of illustration, it will be assumed that, except for timing signals and as otherwise stated, all signals are at a low level when activated. System bus drive enable signal 79 and extend request signal 118 are both coupled to AND gate 126. The output of AND gate 126 is coupled to storage element 128, which is preferably a D-type flip-flop, but, as is the case generally throughout this description, equivalent logic circuit elements can be used instead. Therefore, storage element 128 can only be set at times when the extend request (Fig. 10, signal D) generated by the node is present and when the node has obtained access to bus 25 for the current bus cycle.

In Fig. 7, storage element 128 is set or reset during subcycle 1 of each bus cycle, using clock signal C1. The output of storage element 128 enables a NAND gate 132. Clock signal C1 is also used as an input to inverter 130 in order to enable NAND gate 132 during subcycles 2 through 6, which is coupled to the output of inverter 130. The open drain line driver 134 is turned on by an active output of NAND gate 132 when the extend bus cycle line 120 is to be driven low.

The preferred embodiment for enable circuitry 124 contained in clock decoder 63 is shown in Fig. 8. In response to the receipt of a conditional bus grant on line 114, a storage element 136, such as a D-type flip-flop, will be set. Storage element 136 is set or reset using clock signal C61 beginning on the sixth subcycle of each bus cycle. If an extend bus cycle signal on extend bus cycle line 120 is activated, storage element 138 will be set using clock signal C45 beginning on the fourth subcycle of each bus cycle. The output of storage element 138 is used to enable AND gate 140. AND gate 140 is also enabled by clock signal C12 beginning on the first subcycle of each bus cycle. The output of AND gate 140 is used to clock data into storage element 142, the data





of a conditional grant on line 114 into storage element 142. CPU 31 is unable to obtain access to bus 25 during the third bus cycle, despite the presence of a conditional grant on line 114 during the second bus cycle.

5 Enable circuitry 124 allows CPU 31 to maintain the bus drive enable signal level (signal C) for the needed bus cycles succeeding the initial access cycle even though CPU 31 is no longer selected by arbiter 28 and is not receiving the conditional grant on line 114. As shown  
10 in Fig. 6, an extend request is asserted on line 118 by extend request generator 111 when CPU 31 demands access to bus 25 during more than one bus cycle in order to perform a multi-cycle transfer. If bus system drive enable signal 79 (signal C) is asserted by CPU 31 during the  
15 third bus cycle, as also shown in Fig. 10, the presence of an extend request (signal D) causes extend cycle circuitry 122 to drive extend bus cycle line 120 during the initial access (third) bus cycle. Therefore, as shown  
20 additionally in Fig. 8, when extend bus cycle line 120 is sampled during subcycles 4 and 5 of the third bus cycle, AND gate 140 will be disabled. As a result, although storage element 142 is coupled to conditional grant signal 114, the contents of storage element 142 cannot be updated because of the activation of the extend bus cycle signal  
25 (signal E). Therefore, CPU 31 will not change the contents of storage element 142 at the beginning of the fourth bus cycle. This causes storage element 142 to maintain the system bus drive enable signal level (signal C) during the succeeding bus cycle, and node 31 will be  
30 able to perform a multi-cycle write transfer during bus cycles 3 and 4. Node 31 will not relinquish control of bus 25 until after extend request generator 111 stops generating the extend request during the fourth bus cycle, as shown in Fig. 10.

35 In accordance with the invention, an arbiter means is coupled to the bus request means of each node for transmitting a conditional bus grant to a selected one of



the nodes in response to the bus requests. A block diagram of the portions of arbiter 28 performing such functions is shown in Fig. 9. As shown in Figs. 6 and 9, bus requests from nodes such as CPU 31 and I/O device 51 are sent on separate commander request lines, such as lines 102 and 106, and separate responder request lines, such as lines 104 and 108. In one preferred embodiment, up to 14 separate nodes 60 are included in system 20.

Arbiter 28, as shown in Fig. 9, includes input buffers and latches 144 for receiving fourteen (14) commander request signals and fourteen responder request signals. Beginning on subcycle 6 of a bus cycle, as shown in Fig. 10, arbiter 28 samples the twenty-eight (28) bus request signals (Fig. 10, signal A) and stores the bus requests in latches 144. The stored data is output from latches 144 to priority selection logic 146 using twenty-eight separate lines, one corresponding to each commander or responder request line. Priority selection logic 146 has fifty-six output lines to the priority encoders 148, two lines corresponding to each request line. From the priority encoders 148, only fourteen lines, one corresponding to each node 60, are output to latches 150. The latches 150 also receive as an input the extend bus cycle line 120. Latches 150 have fourteen output lines, one corresponding to each node 60, that are fed back to priority selection logic 146 and are also sent to output buffers 152. The output buffers 152 are coupled to the fourteen conditional bus grant lines, such as lines 114 and 116, coupled to the nodes 60.

The arbiter means according to the present invention may include means for executing a round-robin algorithm for determining the selected one of the plurality of nodes. Arbiter means may also include means for determining as the selected node a node generating a responder request prior to selecting a node generating a commander request. In the arbiter 28 shown in Fig. 9, during any given bus cycle, the lines from input buffers



and latches 144 will contain signal levels corresponding to commander and responder request lines, such as lines 102, 104, 106, and 108, on which a bus request was present during the preceding bus cycle.

5           The elements shown in Fig. 9 perform the arbitration functions. Priority selection logic 146 and priority encoder 148 act as an arbitration queue, and selection logic 146 selects, for the fourteen incoming commander requests and the fourteen incoming responder  
10 requests one of two output lines for each enabled request line in order to execute a round-robin algorithm.

          In the preferred embodiment, twenty-eight locations for responder requests form a first queue and twenty-eight locations for commander requests form a  
15 second queue. Responder bus requests, which are included in the first queue, will be given higher priority than commander bus requests. Although only fourteen commander and fourteen responder bus request signals are input to the arbiter 28, there are twenty-eight locations in each  
20 of the two queues for each set of fourteen requests, so that each request can be assigned to one of two priorities. A high priority array of 14 locations for each queue is executed first, and a low priority array of fourteen locations is executed last for each queue. As  
25 embodied herein, from startup or a period of inactivity, all bus requests are assigned to the high rather than the low priority array of priority selection logic 146 output lines.

          During active periods, priority selection logic  
30 146 determines in which of the two priorities to place each incoming request within its respective (responder or commander) queue based on fourteen lines fed back to logic 146 from latches 150. An activated signal will be present on only one of the fourteen lines fed back from latches  
35 150, and this line will correspond to the node 60 that received the conditional bus grant during the preceding bus cycle. In one preferred implementation, a node having

MBS

a higher ID, or node number, is given higher priority. Thus, the node with ID number 14 will be selected first to receive a conditional bus grant, followed by the nodes with ID numbers 13, 12, etc.

5           A-round robin algorithm can be implemented because the feedback from latches 150 allows priority selection logic 146 to place into the low priority array all bus requests from nodes having IDs greater than or equal to that of the node to which the condition bus grant  
10 (Fig. 10, signal B) was previously transmitted. After all nodes with active requests have been granted the bus 25, the high priority array is empty of all entries and all requests will be placed back in the high priority array. This algorithm ensures that all nodes in a given queue, i.e., responder or commander, shall obtain access to the bus 25 before any other nodes in the same queue obtain access for a second time.

15           The levels of the input signals on the fifty-six lines received by priority encoders 148 determine which node 60 will be selected to receive the next conditional grant. In one example, priority selection logic 146 places a responder request from the node with ID number 2 in the high priority array, a responder request from the node with ID number 14 in the low priority array, a  
20 commander request from the node with ID number 3 in the high priority array, and a commander request from the node with ID number 13 in the low priority array. During the current bus cycle, priority encoders 148 will select only one of fourteen output lines, which line corresponds to  
25 the node to which a conditional grant is transmitted during the current bus cycle. In this example, the responder request from the node with ID number 2 will be given the highest priority, and therefore, only the input line to latches 150 corresponding to the node with ID  
30 number 2 will be enabled. The latch 150 corresponding to the node with ID number 2 will be set, and will drive the corresponding output buffer 152 in order to transmit a



conditional bus grant (Fig. 10, signal B) to a selected node with ID number 2. The feedback of fourteen lines from latches 150 to priority selection logic 146 will be updated to reflect that the node with ID number 2 was the last node 60 to receive a conditional grant, and therefore priority selection logic 146 will place any bus request from the node with ID numbers 2 into the low priority array during the next bus cycle. Thus, a responder request from any node 60 other than the nodes with ID numbers 2 or 14 will have the highest priority during the next bus cycle. If more than one responder with a node IDs other than 2 or 14 make a request for the next cycle, then the responder with the highest node ID will have the highest priority during the next cycle. The commander requests become the highest priority only when no responder requests are present.

The arbiter 28 of the present invention also may include means responsive to the activation of an extend bus cycle signal for ensuring that, while the extend bus cycle signal is activated, the selected node remains the same as the node to which the conditional bus grant was transmitted during the previous bus cycle. As shown in Fig. 9, extend bus cycle line 120 is coupled to latches 150. At times when the extend bus cycle signal is activated during a bus cycle, the output from priority encoders 148 cannot be loaded into latches 150. Therefore, the contents of latches 150 will remain the same, causing the conditional bus grant (Fig. 10, signal B) to be transmitted to the same selected node 60 in consecutive bus cycles. Similarly, the feedback to priority selection logic 146 will remain the same. This prevents a node from being assigned to the lower priority array that was unable to obtain access to bus 25 because another node was executing a multi-cycle transfer.

In the preferred embodiment of the invention, the extend bus cycle line 120 includes a wired-OR connection to each of the plurality of nodes 60. Thus,





whenever one node activates an extend bus cycle signal, each of the other nodes receives it and is prevented from obtaining access to the bus 25 even if the node has received a conditional grant. The extend bus cycle line 5 120 is an open drain line and is terminated on the backplane of the system 20 with a pair of resistive dividers, each consisting of 126 ohms to a +5 volts supply and 500 ohms to ground. This provides a Thevenin equivalent termination of approximately 50 ohms tied to +4 10 volts. The extend bus cycle lines 120 are also series terminated at the driver 134 (Fig. 7) with a resistance of about 20 ohms, which reduces peak output current, and thus noise on the power and ground lines, and provides impedance matching between driver 134 (with an output 15 resistance as low as 2 ohms) and the backplane (impedance typically 20-50 ohms depending on loading).

In the preferred embodiment of the invention, there are several rules on the use of the extend bus cycle signal (Fig. 10, signal E). The extend bus cycle signal 20 is used only to implement multi-cycle transfers; it is not available to commanders to initiate multiple transactions. The only node 60 that may activate the extend bus cycle signal is a node that currently has access to the bus 25. By activating its extend bus cycle line, a node 60 that is 25 currently the transmitter on to bus 25 guarantees that it will be the transmitter on the bus 25 in the next bus cycle, independent of the priority of its bus request signal (signal 14). Finally, it is preferable that no node 60 be allowed to activate an extend bus cycle signal 30 for more than four consecutive bus cycles.

The result of the present invention is a reduction in arbitration and system bus cycle time without requiring additional backplane pins. In the arbitration method of this invention, the central arbiter 35 28 selects a particular node and issues a conditional grant. That grant can be issued more quickly because it is transmitted before a final determination is made



whether access to the bus 25 will actually transfer to another node during the next bus cycle. Each of the nodes 60 contains logic that examines an extend bus cycle signal to determine whether the conditional grant from the  
5 central arbiter 28 causes that node to become a transmitter. Once a node becomes a transmitter, its logic allows it to activate the extend bus cycle signal in order to maintain access to the bus 25 at times when that node is executing a multi-cycle transfer. This invention thus  
10 guarantees that no other node will gain access to the bus 25 until the current transmitter has completed its multi-cycle transfer.

It will be apparent to those skilled in the art that various modifications and variations can be made in the arbitration scheme of the present invention without departing from the scope or spirit of the invention.  
15 Thus, it is intended that the present invention could cover the modifications and variations of this invention provided they come within the scope of the appended claims and their equivalents.  
20



MVS

THE CLAIMS DEFINING THE INVENTION ARE AS FOLLOWS:

1. A responder node coupled to a central arbiter by a commander request line, a responder request line, and a grant line corresponding exclusively to the responder node, wherein the central arbiter provides a conditional bus grant to a node generating a responder bus request prior to providing a conditional bus grant to a node generating a commander bus request, the node coupled to each of a plurality of other nodes by a shared extend bus cycle line and by a pended bus, wherein a node becomes a transmitter in order to transfer a message, including a command or including return data, on the pended bus during one or more cycles of the bus, wherein a commander node initiates a transaction on the pended bus by making a command transfer, wherein a responder node completes the transaction on the pended bus by making a return data transfer in response to the command transfer, and wherein a node can access the pended bus after the commander node initiates a transaction and before the responder node completes the transaction, the responder node comprising:

responder bus request means, coupled to the responder request line, for generating a responder bus request and synchronously transmitting the responder bus request on the responder request line at times when return data is to be transferred from the responder node onto the bus;

extend request means for generating an extend request for the responder node at times when the responder node requires more than one bus cycle to transfer a message;

extend cycle means, coupled to the extend request means and to the extend bus cycle line, for activating an extend bus cycle signal on the extend bus cycle line when the responder node becomes a transmitter at times when the extend request for the responder node is present; and



bus access means, coupled to the grant line and to the extend bus cycle line, for obtaining control of the pended bus to enable the responder node to become a transmitter during an initial access cycle, in response to receipt of a conditional bus grant on the grant line, at times when an extend bus cycle signal is not activated on the extend bus cycle line by any of the other nodes, and for maintaining control of the pended bus to enable the responder node to remain the transmitter during bus cycles succeeding the initial access cycle at times when the extend bus cycle signal is activated by the responder node.

2. A responder node in accordance with claim 1, in which the bus access means includes means for asserting a system bus drive enable signal in the responder node to enable the responder node to obtain control of the pended bus during an initial access cycle, in response to receipt of a conditional bus grant on the grant line, at times when an extend bus cycle signal is not activated on the extend bus cycle line by any of the other nodes, and for asserting the system bus drive enable signal to enable the responder node to maintain control of the pended bus during bus cycles succeeding the initial access cycle at times when the extend bus cycle signal is activated by the responder node.

3. A node in accordance with claim 2 in which the bus access means includes:

a first circuit for asserting the system bus drive enable signal during the initial access cycle; and  
a second circuit for extending the system bus drive enable signal while the extend bus cycle signal is activated.

4. A node in accordance with claim 1 wherein the extend request means includes means for maintaining the extend request until the node is the transmitter for a sufficient number of bus cycles to transfer the entire message.





and

bus access means, coupled to the grant line, for obtaining control of the pended bus to enable the responder node to become a transmitter during an initial access cycle, in response to receipt of a conditional bus grant on the grant line, at times when an extend bus cycle signal is not activated by any of the other nodes, and for maintaining control of the pended bus to enable the responder node to remain the transmitter during bus cycles succeeding the initial access cycle at times when the extend bus cycle signal is activated by the responder node.

8. A responder node in accordance with claim 7, in which the bus access means includes means for asserting a system bus drive enable signal in the responder node to enable the responder node to obtain control of the pended bus during an initial access cycle, in response to receipt of a conditional bus grant on the grant line, at times when an extend bus cycle signal is not activated by any of the other nodes, and for asserting the system bus drive enable signal to enable the responder node to maintain control of the pended bus during bus cycles succeeding the initial access cycle at times when the extend bus cycle signal is activated by the responder node.

9. A node in accordance with claim 8 in which the bus access means includes:

a first circuit for asserting the system bus drive enable signal during the initial access cycle; and

a second circuit for extending the system bus drive enable signal while the extend bus cycle signal is activated.

10. A node in accordance with claim 7 wherein the extend request means includes means for maintaining the extend request until the node is the transmitter for a sufficient number of bus cycles to transfer the entire message.

11. A node in accordance with claim 10 wherein the



node completes the transfer of the message during a last one of the bus cycles, and wherein the means for maintaining the extend request includes means for maintaining the extend request until the bus cycle preceding the last bus cycle.

12. A node according to claim 7 wherein the extend request means includes means for generating the extend request during the initial access cycle.

13. A responder node coupled to a central arbiter by a commander request line, a responder request line, and a grant line corresponding exclusively to the responder node, and coupled to each of a plurality of other nodes by a shared extend bus cycle line and by a pended bus, wherein a node becomes a transmitter in order to transfer a message, including a command or including return data, on the pended bus during one or more cycles of the bus, wherein a commander node initiates a transaction on the pended bus by making a command transfer, wherein a responder node completes the transaction on the pended bus by making a return data transfer in response to the command transfer, and wherein a node can access the pended bus after the commander node initiates a transaction and before the responder node completes the transaction, the responder node comprising:

responder bus request means, coupled to the responder request line, for generating a responder bus request and synchronously transmitting the responder bus request on the responder request line at times when return data is to be transferred from the responder node onto the bus;

extend request means for generating an extend request for the responder node at times when the responder node requires more than one bus cycle to transfer a message;

extend cycle means, coupled to the extend request means and to the extend bus cycle line, for activating an extend bus cycle signal on the extend bus

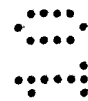
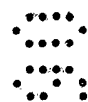
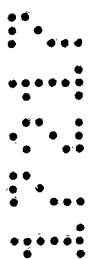

cycle line when the responder node becomes a transmitter at times when the extend request for the responder node is present; and

bus access means, coupled to the grant line and to the extend bus cycle line, for obtaining control of the pended bus to enable the responder node to become a transmitter during an initial access cycle, in response to receipt of a conditional bus grant on the grant line, at times when an extend bus cycle signal is not activated on the extend bus cycle line by any of the other nodes, and for maintaining control of the pended bus to enable the responder node to remain the transmitter during bus cycles succeeding the initial access cycle at times when the extend bus cycle signal is activated by the responder node.

14. A responder node in accordance with claim 13, in which the bus access means includes means for asserting a system bus drive enable signal in the responder node to enable the responder node to obtain control of the pended bus during an initial access cycle, in response to receipt of a conditional bus grant on the grant line, at times when an extend bus cycle signal is not activated on the extend bus cycle line by any of the other nodes, and for asserting the system bus drive enable signal to enable the responder node to maintain control of the pended bus during bus cycles succeeding the initial access cycle at times when the extend bus cycle signal is activated by the responder node.

15. A method by which a responder node obtains access to a pended bus, wherein the responder node is coupled to a commander request line, a responder request line, and a grant line corresponding exclusively to the responder node, wherein the responder node is coupled to each of a plurality of other nodes by the pended bus, wherein a node becomes a transmitter in order to transfer a message, including a command or including return data, on the pended bus during one or more cycles of the bus,





wherein a commander node initiates a transaction on the pended bus by making a command transfer, wherein a responder node completes the transaction on the pended bus by taking a return data transfer in response to the command transfer, and wherein a node can access the pended bus after the commander node initiates a transaction and before the responder node completes the transaction, the method comprising the steps of:

generating a responder bus request and transmitting the responder bus request on the responder request line at times when return data is to be transferred from the responder node onto the bus;

generating an extend request for the responder node at times when the responder node requires more than one bus cycle to transfer a message;

activating an extend bus cycle signal when the responder node becomes a transmitter at times when the extend request for the responder node is present;

obtaining control of the pended bus during an initial access cycle, in response to receipt of a conditional bus grant on the grant line, at times when an extend bus cycle signal is not activated by any of the other nodes; and

maintaining control of the pended bus during bus cycles succeeding the initial access cycle at times when the extend bus cycle signal is activated by the responder node.

16. A method by which a node obtains access to a pended bus, wherein the node is coupled to a central arbiter by a commander request line, a responder request line, and a grant line corresponding exclusively to the node, wherein the central arbiter provides a conditional bus grant to a node generating a responder bus request prior to providing a conditional bus grant to a node generating a commander bus request, wherein the node is coupled to each of a plurality of other nodes by a shared extend bus cycle line and by the pended bus, wherein a

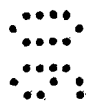
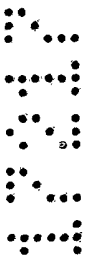

node becomes a transmitter in order to transfer a message, including a command or including return data, on the pended bus during one or more cycles of the bus, wherein a commander node initiates a transaction on the pended bus by making a command transfer, wherein a responder node completes the transaction on the pended bus by making a return data transfer in response to the command transfer, and wherein a node can access the pended bus after the commander node initiates a transaction and before the responder node completes the transaction, the method comprising the steps of:

generating a commander bus request and synchronously transmitting the commander bus request on the commander request line at times when a command is to be transferred from the node onto the bus;

generating a responder bus request and synchronously transmitting the responder bus request on the responder request line at times when return data is to be transferred from the node onto the bus;

generating an extend request for the node at times when the node requires more than one bus cycle to transfer a message;

activating an extend bus cycle signal on the extend bus cycle line when the node becomes a transmitter at times when the extend request for the node is present;

obtaining control of the pended bus during an initial access cycle, in response to receipt of a conditional bus grant on the grant line, at times when an extend bus cycle signal is not activated on the extend bus cycle line by any of the other nodes; and

maintaining control of the pended bus during bus cycles succeeding the initial access cycle at times when the extend bus cycle signal is activated by the node.

17. A commander node coupled to a commander request line, a responder request line, and a grant line corresponding exclusively to the node, and coupled to each of a plurality of other nodes by a pended bus, wherein a

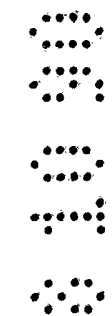

node becomes a transmitter in order to transfer a message, including a command or including return data, on the pended bus during one or more cycles of the bus, wherein a commander node initiates a transaction on the pended bus by making a command transfer, wherein a responder node completes the transaction on the pended bus by making a return data transfer in response to the command transfer, and wherein a node can access the pended bus after the commander node initiates a transaction and before the responder node completes the transaction, the commander node comprising:

commander bus request means, coupled to the commander request line, for generating a commander bus request and transmitting the commander bus request on the commander request line at times when a command is to be transferred from the commander node onto the bus;

extend request means for generating an extend request for the commander node at times when the commander node requires more than one bus cycle to transfer a message;

extend cycle means, coupled to the extend request means, for activating an extend bus cycle signal when the commander node becomes a transmitter at times when the extend request for the commander node is present; and

bus access means, coupled to the grant line, for obtaining control of the pended bus to enable the commander node to become a transmitter during an initial access cycle, in response to receipt of a conditional bus grant on the grant line, at times when an extend bus cycle signal is not activated by any of the other nodes, and for maintaining control of the pended bus to enable the commander node to remain the transmitter during bus cycles succeeding the initial access cycle at times when the extend bus cycle signal is activated by the commander node.

18. A commander node in accordance with claim 17, in which the bus access means includes means for asserting a

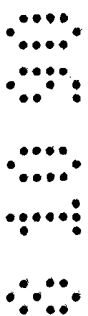
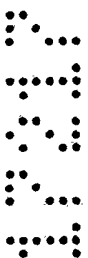

system bus drive enable signal in the commander node to enable the commander node to obtain control of the pended bus during an initial access cycle, in response to receipt of a conditional bus grant on the grant line, at times when an extend bus cycle signal is not activated by any of the other nodes, and for asserting the system bus drive enable signal to enable the commander node to maintain control of the pended bus during bus cycles succeeding the initial access cycle at times when the extend bus cycle signal is activated by the commander node.

19. A commander node coupled to a central arbiter by a commander request line, a responder request line, and a grant line corresponding exclusively to the node, and coupled to each of a plurality of other nodes by a shared extend bus cycle line and by a pended bus, wherein a node becomes a transmitter in order to transfer a message, including a command or including return data, on the pended bus during one or more cycles of the bus, wherein a commander node initiates a transaction on the pended bus by making a command transfer, wherein a responder node completes the transaction on the pended bus by making a return data transfer in response to the command transfer, and wherein a node can access the pended bus after the commander node initiates a transaction and before the responder node completes the transaction, the commander node comprising:

commander bus request means, coupled to the commander request line, for generating a commander bus request and synchronously transmitting the commander bus request on the commander request line at times when a command is to be transferred from the commander node onto the bus;

extend request means for generating an extend request for the commander node at times when the commander node requires more than one bus cycle to transfer a message;

extend cycle means, coupled to the extend

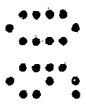

request means and to the extend bus cycle line, for activating an extend bus cycle signal on the extend bus cycle line when the commander node becomes a transmitter at times when the extend request for the commander node is present; and

bus access means, coupled to the grant line and to the extend bus cycle line, for obtaining control of the pended bus to enable the commander node to become a transmitter during an initial access cycle, in response to receipt of a conditional bus grant on the grant line, at times when an extend bus cycle signal is not activated on the extend bus cycle line by any of the other nodes, and for maintaining control of the pended bus to enable the commander node to remain the transmitter during bus cycles succeeding the initial access cycle at times when the extend bus cycle signal is activated by the commander node.

20. A commander node in accordance with claim 19, in which the bus access means includes means for asserting a system bus drive enable signal in the commander node to enable the commander node to obtain control of the pended bus during an initial access cycle, in response to receipt of a conditional bus grant on the grant line, at times when an extend bus cycle signal is not activated on the extend bus cycle line by any of the other nodes, and for asserting the system bus drive enable signal to enable the commander node to maintain control of the pended bus during bus cycles succeeding the initial access cycle at times when the extend bus cycle signal is activated by the commander node.

21. A commander node coupled to a central arbiter by a commander request line, a responder request line, and a grant line corresponding exclusively to the node, wherein the central arbiter provides a conditional bus grant to a node generating a responder bus request prior to providing a conditional bus grant to a node generating a commander bus request, the node coupled to each of a plurality of other nodes by a shared extend bus cycle line and by a pended bus, wherein a node becomes a transmitter in order

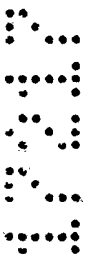

to transfer a message, including a command or including return data, on the pended bus during one or more cycles of the bus, wherein a commander node initiates a transaction on the pended bus by making a command transfer, wherein a responder node completes the transaction on the pended bus by making a return data transfer in response to the command transfer, and wherein a node can access the pended bus after the commander node initiates a transaction and before the responder node completes the transaction, the commander node comprising:

commander bus request means, coupled to the commander request line, for generating a commander bus request and synchronously transmitting the commander bus request on the commander request line at times when a command is to be transferred from the commander node onto the bus;

extend request means for generating an extend request for the commander node at times when the commander node requires more than one bus cycle to transfer a message;

extend cycle means, coupled to the extend request means and to the extend bus cycle line, for activating an extend bus cycle signal on the extend bus cycle line when the commander node becomes a transmitter at times when the extend request for the commander node is present; and

bus access means, coupled to the grant line and to the extend bus cycle line, for obtaining control of the pended bus to enable the commander node to become a transmitter during an initial access cycle, in response to receipt of a conditional bus grant on the grant line, at times when an extend bus cycle signal is not activated on the extend bus cycle line by any of the other nodes, and for maintaining control of the pended bus to enable the commander node to remain the transmitter during bus cycles succeeding the initial access cycle at times when the extend bus cycle signal is activated by the commander node.



22. A commander node in accordance with claim 21, in which the bus access means includes means for asserting a system bus drive enable signal in the commander node to enable the commander node to obtain control of the pended bus during an initial access cycle, in response to receipt of a conditional bus grant on the grant line, at times when an extend bus cycle signal is not activated on the extend bus cycle line by any of the other nodes, and for asserting the system bus drive enable signal to enable the commander node to maintain control of the pended bus during bus cycles succeeding the initial access cycle at times when the extend bus cycle signal is activated by the commander node.

23. A method by which a commander node obtains access to a pended bus, wherein the commander node is coupled to a commander request line, a responder request line, and a grant line corresponding exclusively to the node, wherein the commander node is coupled to each of a plurality of other nodes by the pended bus, wherein a node becomes a transmitter in order to transfer a message, including a command or including return data, on the pended bus during one or more cycles of the bus, wherein a commander node initiates a transaction on the pended bus by making a command transfer, wherein a responder node completes the transaction on the pended bus by making a return data transfer in response to the command transfer, and wherein a node can access the pended bus after the commander node initiates a transaction and before the responder node completes the transaction, the method comprising the steps of:

generating a commander bus request and transmitting the commander bus request on the commander request line at times when a command is to be transferred from the commander node onto the bus;

generating a commander bus request for the commander node at times when the commander node requires more than one bus cycle to transfer a message;



activating an extend bus cycle signal when the commander node becomes a transmitter at times when the extend request for the commander node is present;

obtaining control of the pended bus during an initial access cycle, in response to receipt of a conditional bus grant on the grant line, at times when an extend bus cycle signal is not activated by any of the other nodes; and

maintaining control of the pended bus during bus cycles succeeding the initial access cycle at times when the extend bus cycle signal is activated by the commander node.

24. A node, coupled to a plurality of request lines corresponding exclusively to the node, and coupled to each of a plurality of other nodes by a pended bus, wherein a node becomes a transmitter in order to transfer a message, including a command or including return data, on the pended bus during one or more cycles of the bus, wherein a commander node initiates a transaction on the pended bus by making a command transfer, wherein a responder node completes the transaction on the pended bus by making a return data transfer in response to the command transfer, and wherein a node can access the pended bus after the commander node initiates a transaction and before the responder node completes the transaction, the node comprising:

bus request means, coupled to the plurality of request lines corresponding exclusively to the node, for generating a bus request and transmitting the bus request on one of the corresponding plurality of request lines at times when a command is to be transferred from the node onto the bus, and for generating a bus request and transmitting the bus request on another one of the corresponding plurality of request lines at times when return data is to be transferred from the node onto the bus;

extend request means for generating an extend





request for the node at times when the node requires more than one bus cycle to transfer a message;

extend cycle means, coupled to the extend request means, for activating an extend bus cycle signal when the node becomes a transmitter at times when the extend request for the node is present; and

bus access means, for obtaining control of the pended bus to enable the node to become a transmitter during an initial access cycle, in response to receipt of a conditional bus grant, at times when an extend bus cycle signal is not activated by any of the other nodes, and for maintaining control of the pended bus to enable the node to remain the transmitter during bus cycles succeeding the initial access cycle at times when the extend bus cycle signal is activated by the node.

25. A node in accordance with claim 24, in which the node is coupled to an arbiter by a grant line corresponding exclusively to the node and by the plurality of request lines corresponding exclusively to the node, and wherein:

the bus access means is coupled to the grant line, for obtaining control of the pended bus to enable the node to become a transmitter during an initial access cycle, in response to receipt of a conditional bus grant on the grant line, at times when an extend bus cycle signal is not activated by any of the other nodes.

26. A node in accordance with claim 25, in which the node is coupled to each of the plurality of the other nodes by an extend bus cycle line, and wherein:

the extend cycle means is coupled to the extend bus cycle line, for activating an extend bus cycle signal on the extend bus cycle line when the node becomes a transmitter at times when the extend request for the node is present; and

the bus access means is coupled to the extend bus cycle line, for obtaining control of the pended bus to enable the node to become a transmitter during an initial



access cycle, in response to receipt of a conditional bus grant on the grant line, at times when an extend bus cycle signal is not activated on the extend bus cycle line by any of the other nodes.

27. A node in accordance with claim 24, in which the node is coupled to each of the plurality of other nodes by an extend bus cycle line, and wherein:

the extend cycle means is coupled to the extend bus cycle line, for activating an extend bus cycle signal on the extend bus cycle line when the node becomes a transmitter at times when the extend request for the node is present; and

the bus access means is coupled to the extend bus cycle line, for obtaining control of the pended bus to enable the node to become a transmitter during an initial access cycle, in response to receipt of a conditional bus grant, at times when an extend bus cycle signal is not activated on the extend bus cycle line by any of the other nodes.

28. A node in accordance with claim 27, in which the node is coupled to an arbiter by the plurality of request lines corresponding exclusively to the node, and wherein:

the bus request means generates a bus request and synchronously transmits the bus request on one of the corresponding plurality of request lines at times when a command is to be transferred from the node onto the bus, and generates a bus request and synchronously transmits the bus request on another one of the corresponding plurality of request lines at times when return data is to be transferred from the node onto the bus.

29. A node in accordance with claim 26, in which the node is coupled to the arbiter by the plurality of request lines corresponding exclusively to the node, and wherein:

the bus request means generates a bus request and synchronously transmits the bus request on one of the corresponding plurality of request lines at times when a command is to be transferred from the node onto the bus,

MB  
SEARCHED  
SERIALIZED  
INDEXED  
FILED

and generates a bus request and synchronously transmits the bus request on another one of the corresponding plurality of request lines at times when return data is to be transferred from the node onto the bus.

30. A node in accordance with claim 25, in which the node is coupled to the arbiter by the plurality of request lines corresponding exclusively to the node, and wherein:

the bus request means generates a bus request and synchronously transmits the bus request on one of the corresponding plurality of request lines at times when a command is to be transferred from the node onto the bus, and generates a bus request and synchronously transmits the bus request on another one of the corresponding plurality of request lines at times when return data is to be transferred from the node onto the bus.

31. A node in accordance with claim 24, in which the node is coupled to an arbiter by the plurality of request lines corresponding exclusively to the node, and wherein:

the bus request means generates a bus request and synchronously transmits the bus request on one of the corresponding plurality of request lines at times when a command is to be transferred from the node onto the bus, and generates a bus request and synchronously transmits the bus request on another one of the corresponding plurality of request lines at times when return data is to be transferred from the node onto the bus.

32. A node in accordance with claim 31, in which the plurality of request lines corresponding exclusively to the node include a commander request line and a responder request line, and in which the arbiter provides a conditional bus grant to a node generating a responder bus request prior to providing a conditional bus grant to a node generating a commander bus request, and wherein:

the bus request means is coupled to the commander request line and to the responder request line, for generating a commander bus request and transmitting the commander bus request on the commander request line at

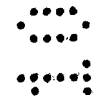
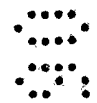
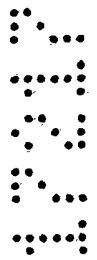

MVS

times when a command is to be transferred from the node onto the bus, and for generating a responder bus request and transmitting the responder bus request on the responder request line at times when return data is to be transferred from the node onto the bus.

33. A node in accordance with claim 30, in which the plurality of request lines corresponding exclusively to the node include a commander request line and a responder request line, and in which the arbiter provides a conditional bus grant to a node generating a responder bus request prior to providing a conditional bus grant to a node generating a commander bus request, and wherein:

the bus request means is coupled to the commander request line and to the responder requests line, for generating a commander bus request and transmitting the commander bus request on to the command request line at times when a command is to be transferred from the node onto the bus, and for generating a responder bus request and transmitting the responder bus request on the responder request line at times when return data is to be transferred from the node onto the bus.

34. A node in accordance with claim 29, in which the plurality of request lines corresponding exclusively to the node include a commander request line and a responder request line, and in which the arbiter provides a conditional bus grant to a node generating a responder bus request prior to providing a conditional bus grant to a node generating a commander bus request, and wherein:

the bus request means is coupled to the commander request line and to the responder request line, for generating a commander bus request and transmitting the commander bus request on the commander request line at times when a command is to be transferred from the node onto the bus, and for generating a responder bus request and transmitting the responder bus request on the responder request line at times when return data is to be transferred from the node onto the bus.



35. A node in accordance with claim 28, in which the plurality of request lines corresponding exclusively to the node include a commander request line and a responder request line, and in which the arbiter provides a conditional bus grant to a node generating a responder bus request prior to providing a conditional bus grant to a node generating a commander bus request, and wherein:

the bus request means is coupled to the commander request line and to the responder request line, for generating a commander bus request and transmitting the commander bus request on the commander request line at times when a command is to be transferred from the node onto the bus, and for generating a responder bus request and transmitting the responder bus request on the responder request line at times when return data is to be transferred from the node onto the bus.

36. A node in accordance with claim 26, in which the plurality of request lines corresponding exclusively to the node include a commander request line and a responder request line, and in which the arbiter provides a conditional bus grant to a node generating a responder bus request prior to providing a conditional bus grant to a node generating a commander bus request, and wherein:

the bus request means is coupled to the commander request line and to the responder request line, for generating a commander bus request and transmitting the commander bus request on the commander request line at times when a command is to be transferred from the node onto the bus, and for generating a responder bus request and transmitting the responder bus request on the responder request line at times when return data is to be transferred from the node onto the bus.

37. A node in accordance with claim 25, in which the plurality of request lines corresponding exclusively to the node include a commander request line and a responder request line, and in which the arbiter provides a conditional bus grant to a node generating a responder bus



request prior to providing a conditional bus grant to a node generating a commander bus request, and wherein:

the bus request means is coupled to the commander request line and to the responder request line, for generating a commander bus request and transmitting the commander bus request on the commander request line at times when a command is to be transferred from the node onto the bus, and for generating a responder bus request and transmitting the responder bus request on the responder request line at times when return data is to be transferred from the node onto the bus.

38. A node in accordance with claim 37, in which the bus access means includes means for asserting a system bus drive enable signal in the node to enable the node to obtain control of the pended bus during an initial access cycle, in response to receipt of a conditional bus grant, at times when an extend bus cycle signal is not activated by any of the other nodes, and for asserting the system bus drive enable signal to enable the node to maintain control of the pended bus during bus cycles succeeding the initial access cycle at times when the extend bus cycle signal is activated by the node.

39. A node in accordance with claim 36, in which the bus access means includes means for asserting a system bus drive enable signal in the node to enable the node to obtain control of the pended bus during an initial access cycle, in response to receipt of a conditional bus grant, at times when an extend bus cycle signal is not activated by any of the other nodes, and for asserting the system bus drive enable signal to enable the node to maintain control of the pended bus during bus cycles succeeding the initial access cycle at times when the extend bus cycle signal is activated by the node.

40. A node in accordance with claim 26, in which the bus access means includes means for asserting a system bus drive enable signal in the node to enable the node to obtain control of the pended bus during an initial access

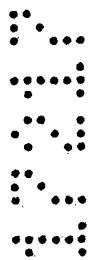

cycle, in response to receipt of a conditional bus grant, at times when an extend bus cycle signal is not activated by any of the other nodes, and for asserting the system bus drive enable signal to enable the node to maintain control of the pended bus during bus cycles succeeding the initial access cycle at times when the extend bus cycle signal is activated by the node.

41. A node in accordance with claim 25, in which the bus access means includes means for asserting a system bus drive enable signal in the node to enable the node to obtain control of the pended bus during an initial access cycle, in response to receipt of a conditional bus grant, at times when an extend bus cycle signal is not activated by any of the other nodes, and for asserting the system bus drive enable signal to enable the node to maintain control of the pended bus during bus cycles succeeding the initial access cycle at times when the extend bus cycle signal is activated by the node.

42. A node in accordance with claim 24, in which the bus access means includes means for asserting a system bus drive enable signal in the node to enable the node to obtain control of the pended bus during an initial access cycle, in response to receipt of a conditional bus grant, at times when an extend bus cycle signal is not activated by any of the other nodes, and for asserting the system bus drive enable signal to enable the node to maintain control of the pended bus during bus cycles succeeding the initial access cycle at times when the extend bus cycle signal is activated by the node.

43. A method by which a node obtains access to a pended bus, wherein the node is coupled to a commander request line, a responder request line, and a grant line corresponding exclusively to the node, wherein the node is coupled to each of a plurality of other nodes by the pended bus, wherein a node becomes a transmitter in order to transfer a message, including a command or including return data, on the pended bus during one or more cycles



MCS

of the bus, wherein a commander node initiates a transaction on the pended bus by making a command transfer, wherein a responder node completes the transaction on the pended bus by making a return data transfer in response to the command transfer, and wherein a node can access the pended bus after the commander node initiates a transaction and before the responder node completes the transaction, the method comprising the steps of:

generating a commander bus request and transmitting the commander bus request on the commander request line at times when a command is to be transferred from the node onto the bus;

generating a responder bus request and transmitting the responder bus request on the responder request line at times when return data is to be transferred from the node onto the bus;

generating an extend request for the node at times when the node requires more than one bus cycle to transfer a message;

activating an extend bus cycle signal when the node becomes a transmitter at times when the extend request for the node is present;

obtaining control of the pended bus during an initial access cycle, in response to receipt of a conditional bus grant on the grant line, at times when an extend bus cycle signal is not activated by any of the other nodes; and

maintaining control of the pended bus during bus cycles succeeding the initial access cycle at times when the extend bus cycle signal is activated by the node.

44. A responder node substantially as hereinbefore described with reference to and as illustrated in the accompanying drawings.

45. A commander node substantially as hereinbefore described with reference to and as illustrated in the accompanying drawings.



MBS



46. A node substantially as hereinbefore described with reference to and as illustrated in the accompanying drawings.

47. A method by which a responder node obtains access to a pended bus substantially as hereinbefore described with reference to and as illustrated in the accompanying drawings.

48. A method by which a commander node obtains access to a pended bus substantially as hereinbefore described with reference to and as illustrated in the accompanying drawings.

49. A method by which a node obtains access to a pended bus substantially as hereinbefore described with reference to and as illustrated in the accompanying drawings.

Dated this 28th Day of September, 1990.

DIGITAL EQUIPMENT CORPORATION  
By Its Patent Attorneys

GRIFFITH HACK & CO.  
Fellows Institute of Patent  
Attorneys of Australia

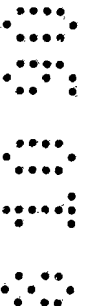

Handwritten initials or mark, possibly 'MFB', in the bottom left corner.

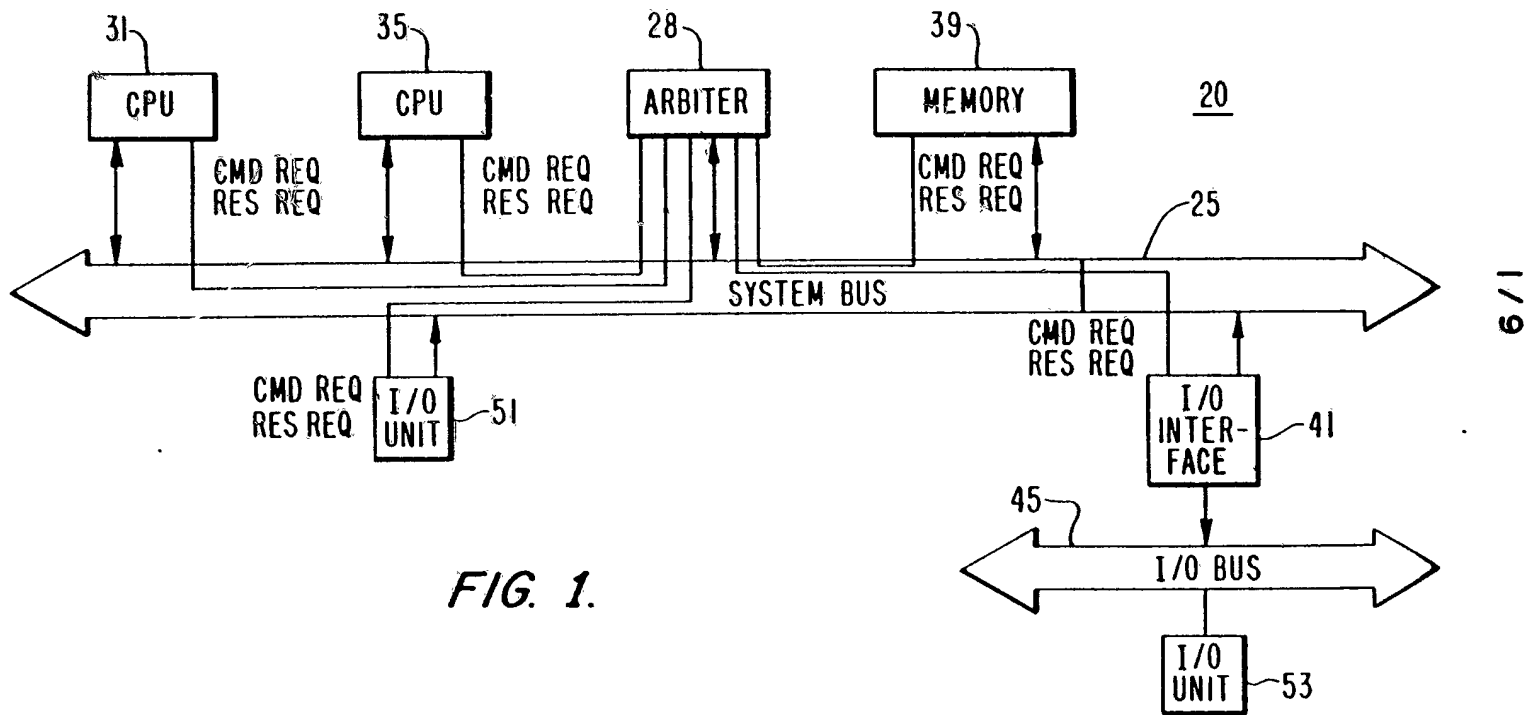

FIG. 1.

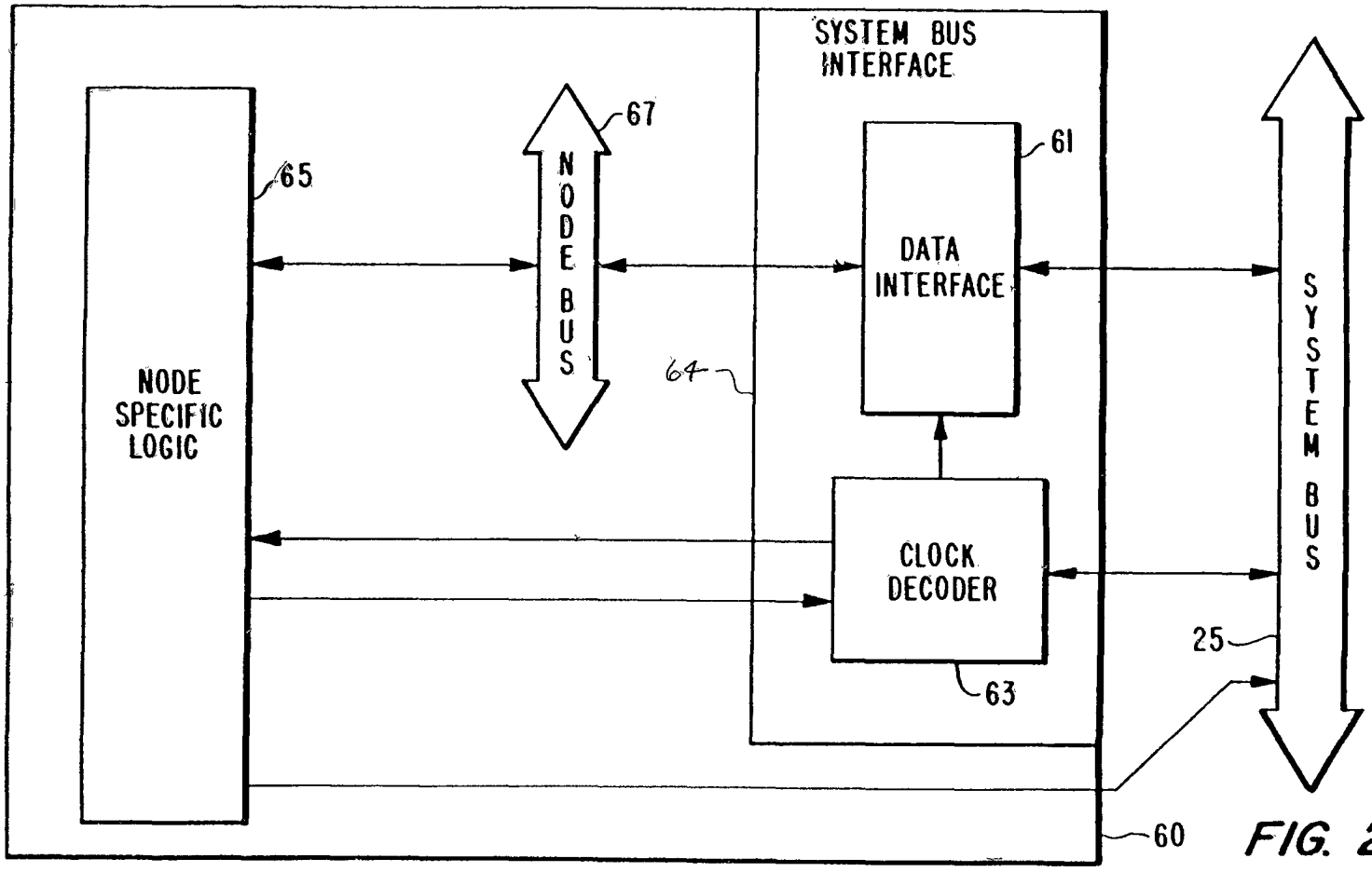

FIG. 2.

FIG. 3.

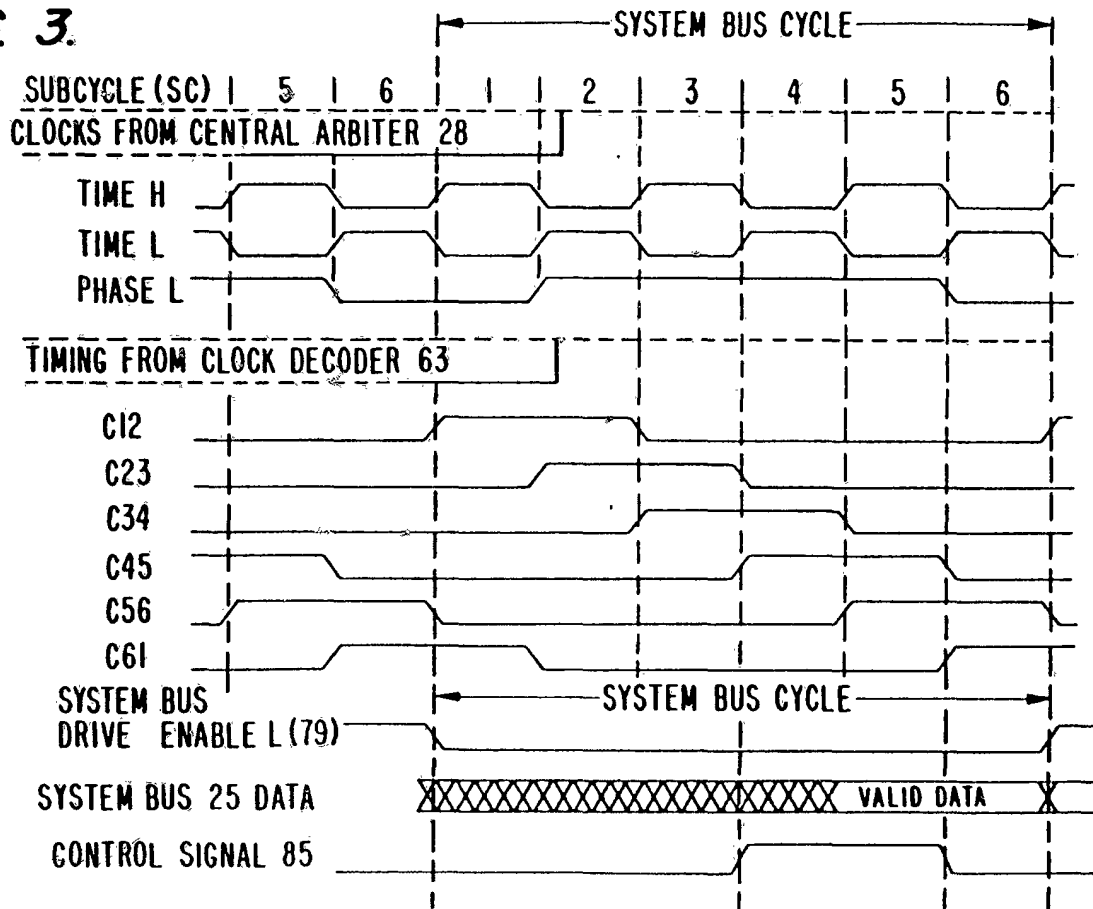

FIG. 4.

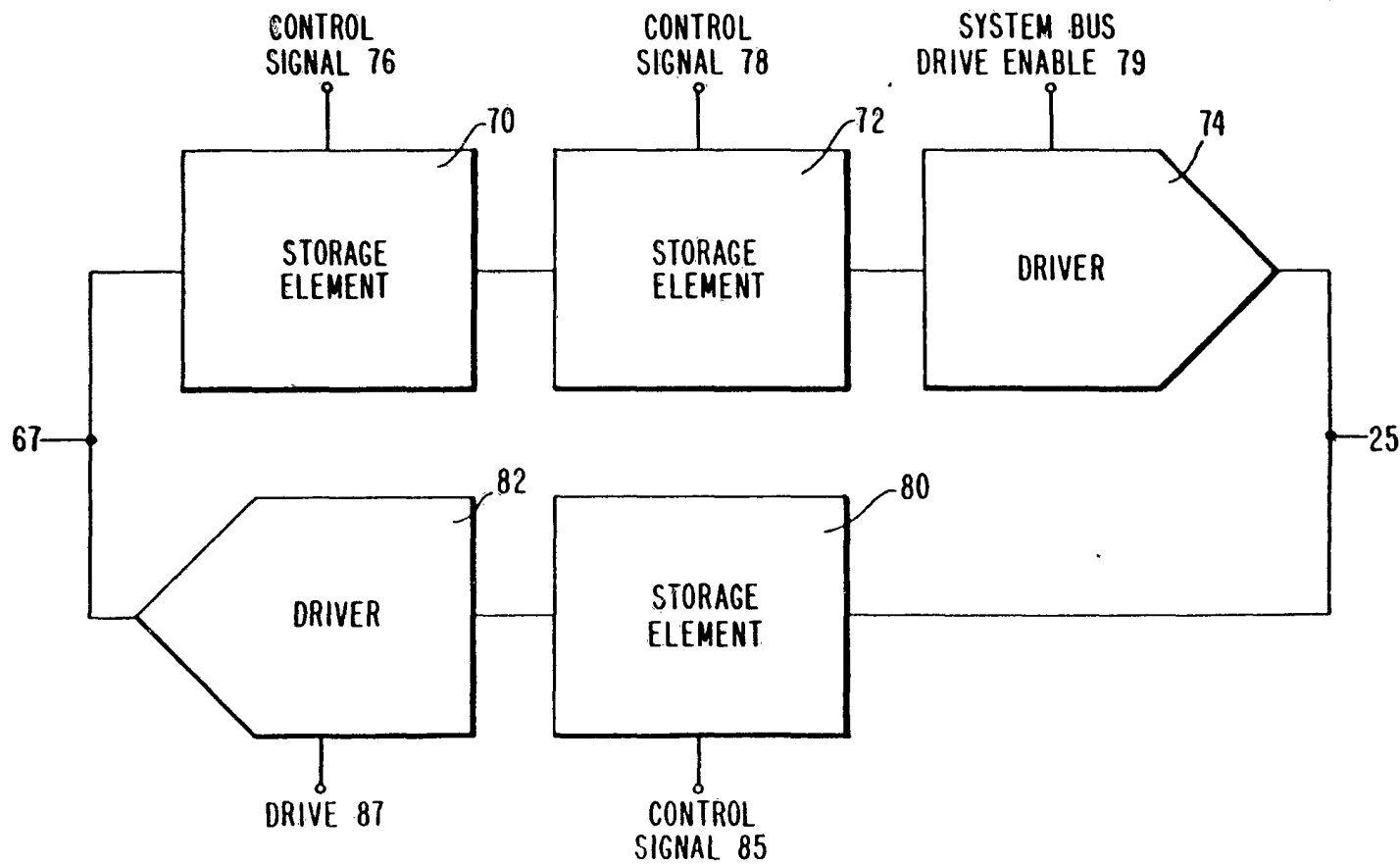
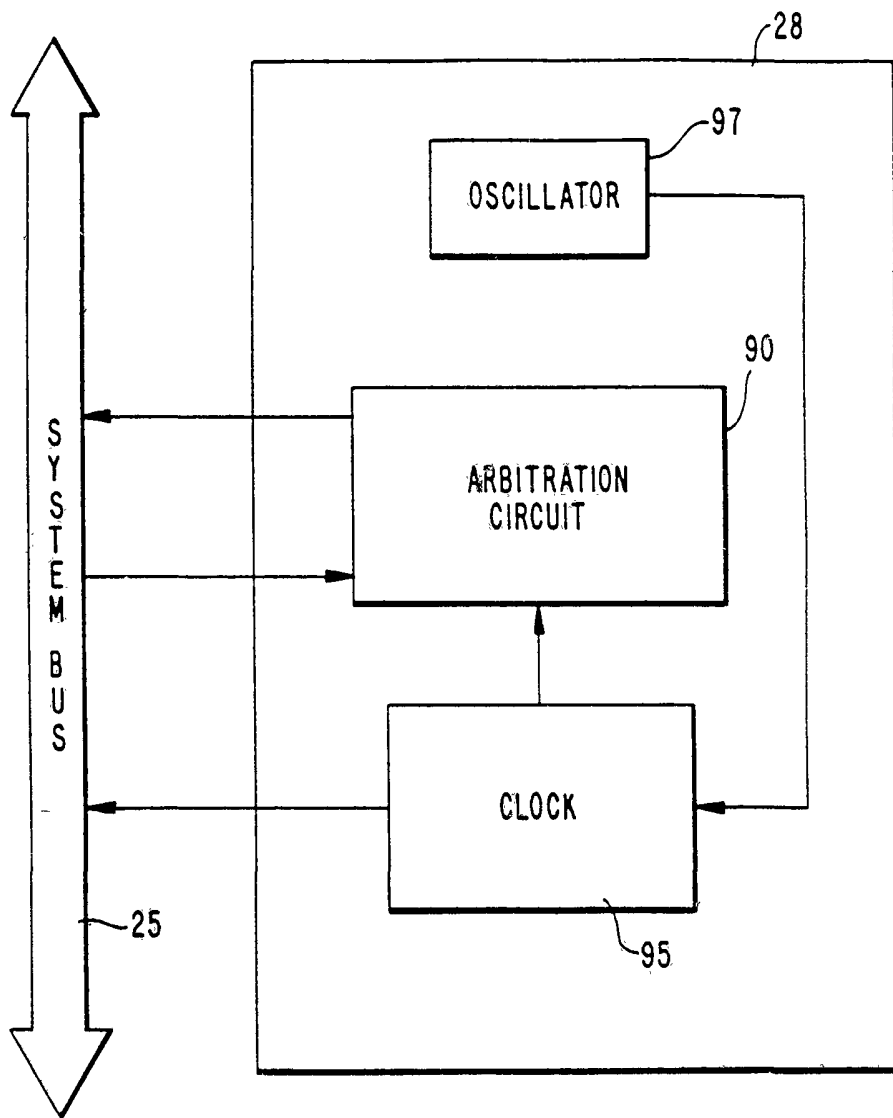

FIG. 5



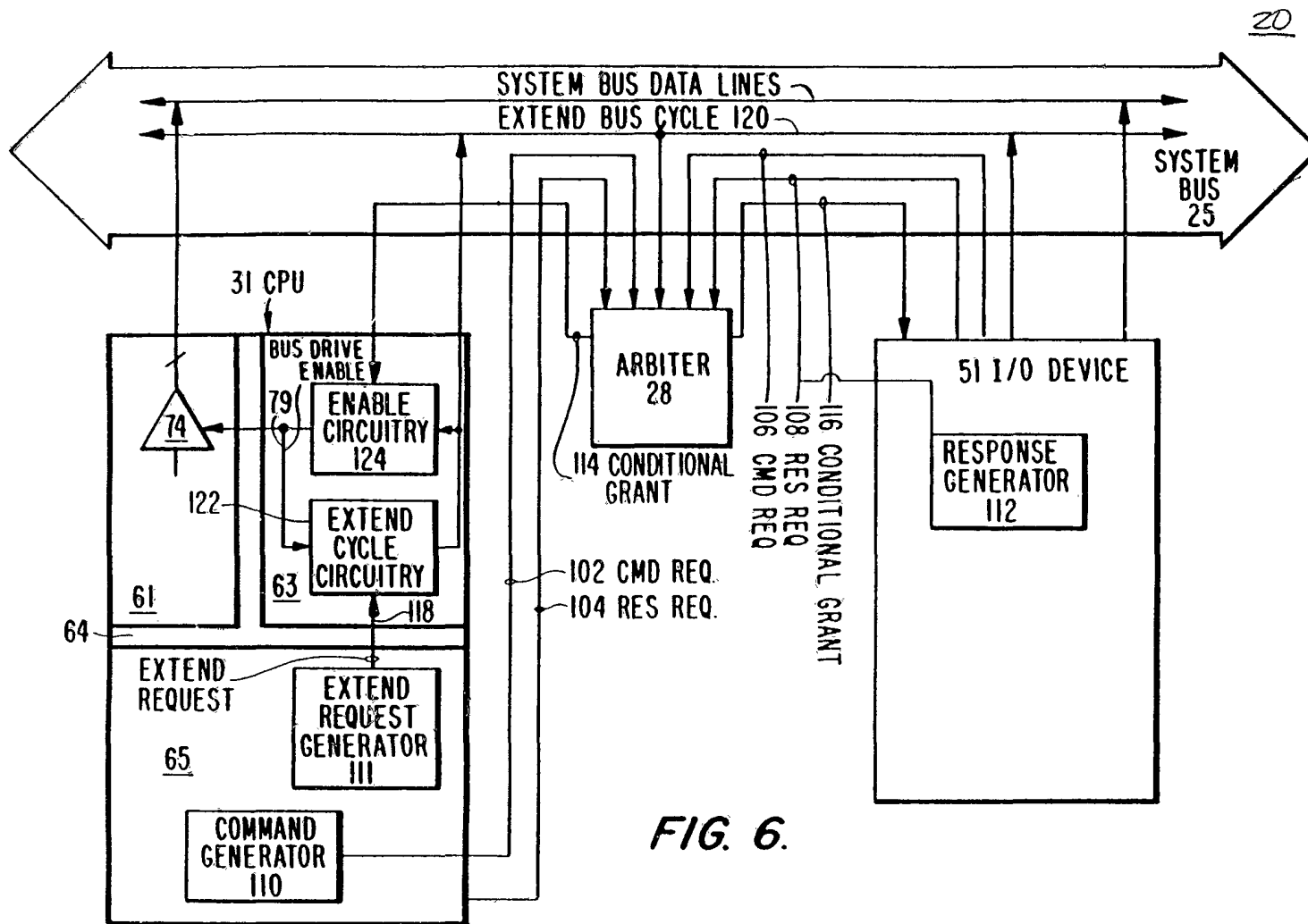

FIG. 6.

FIG. 7.

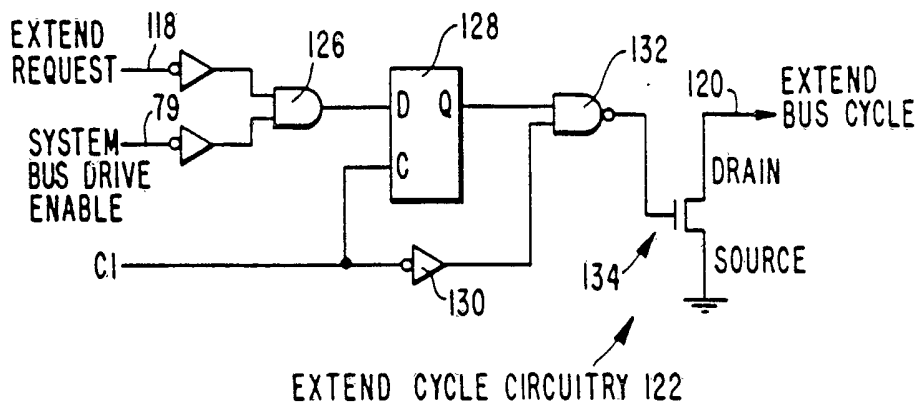

FIG. 8.

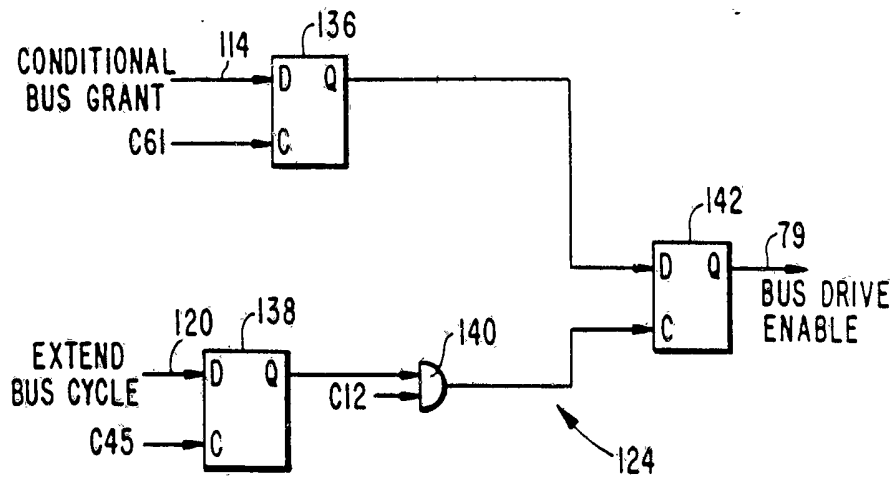



FIG. 9.

ARBITER BLOCK DIAGRAM

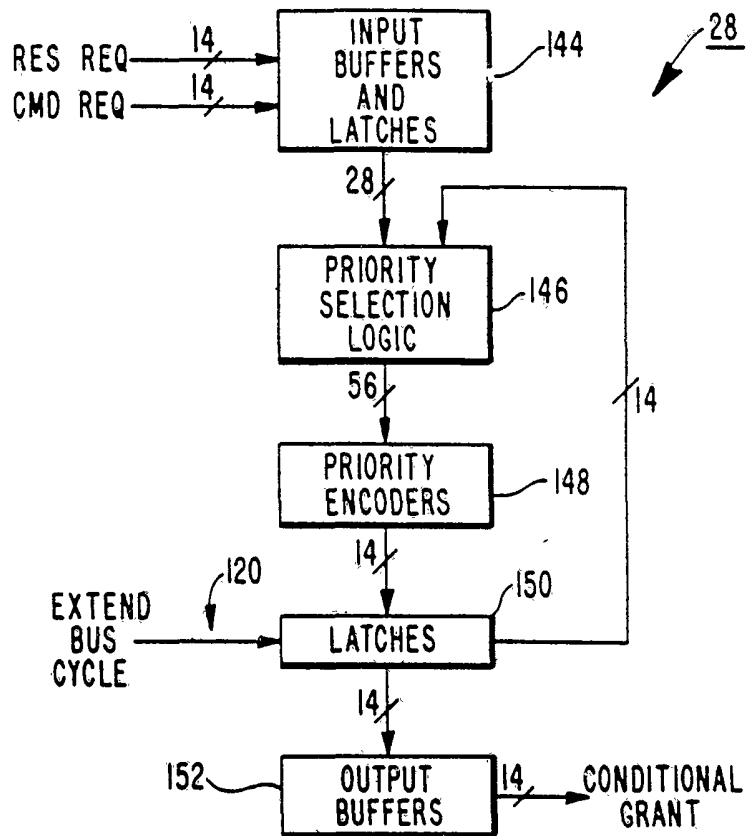
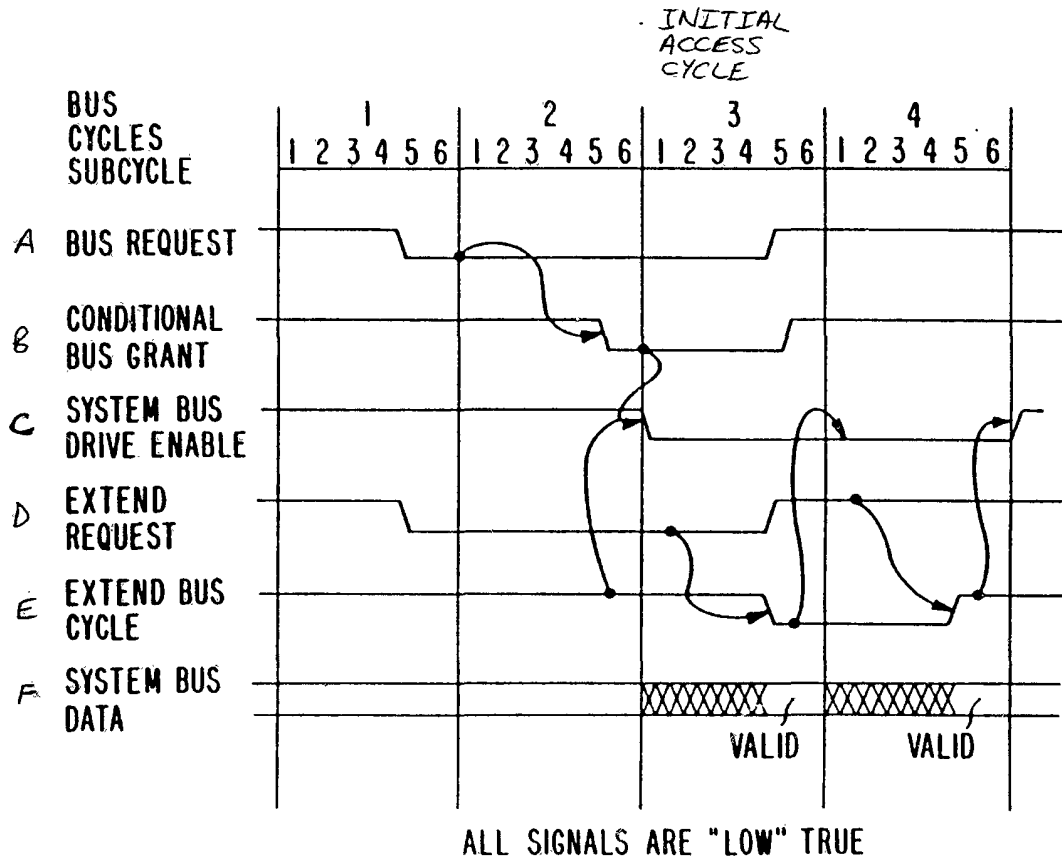

FIG. 10.

SIGNAL



# INTERNATIONAL SEARCH REPORT

International Application No PCT/US 88/01358

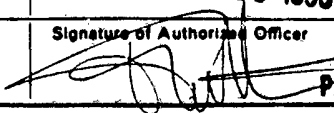
<b>I. CLASSIFICATION OF SUBJECT MATTER</b> (if several classification symbols apply, indicate all) <sup>6</sup>		
According to International Patent Classification (IPC) or to both National Classification and IPC		
IPC <sup>4</sup> : G 06 F 13/36		
<b>II. FIELDS SEARCHED</b>		
Minimum Documentation Searched <sup>7</sup>		
Classification System	Classification Symbols	
IPC <sup>4</sup>	G 06 F	
Documentation Searched other than Minimum Documentation to the Extent that such Documents are Included in the Fields Searched <sup>8</sup>		
<b>III. DOCUMENTS CONSIDERED TO BE RELEVANT <sup>9</sup></b>		
Category <sup>9</sup>	Citation of Document, <sup>11</sup> with indication, where appropriate, of the relevant passages <sup>12</sup>	Relevant to Claim No. <sup>13</sup>
X	IBM Technical Disclosure Bulletin, vol. 28, no. 12, May 1986 (New York, US) "High-Speed processor bus arbitration", pages 5329-5333 see the whole document	1,3,4
A	-----	5,6
<p><sup>9</sup> Special categories of cited documents: <sup>10</sup></p> <p>"A" document defining the general state of the art which is not considered to be of particular relevance</p> <p>"E" earlier document but published on or after the international filing date</p> <p>"L" document which may throw doubts on priority claim(s) or which is cited to establish the publication date of another citation or other special reason (as specified)</p> <p>"O" document referring to an oral disclosure, use, exhibition or other means</p> <p>"P" document published prior to the international filing date but later than the priority date claimed</p> <p>"T" later document published after the international filing date or priority date and not in conflict with the application but cited to understand the principle or theory underlying the invention</p> <p>"X" document of particular relevance; the claimed invention cannot be considered novel or cannot be considered to involve an inventive step</p> <p>"Y" document of particular relevance; the claimed invention cannot be considered to involve an inventive step when the document is combined with one or more other such documents, such combination being obvious to a person skilled in the art.</p> <p>"Z" document member of the same patent family</p>		
<b>IV. CERTIFICATION</b>		
Date of the Actual Completion of the International Search	Date of Mailing of this International Search Report	
27th July 1988	23 AUG 1988	
International Searching Authority	Signature of Authorizing Officer	
EUROPEAN PATENT OFFICE	 <b>P.C.G. VAN DER PUTTEN</b>	