(12) UK Patent Application (19) GB (11) 2 087 240 A

(21) Application No **8134447**
(22) Date of filing **16 Nov 1981**
(30) Priority data
(31) **207522**
(32) **17 Nov 1980**
(33) **United States of America (US)**
(43) Application published
26 May 1982
(51) **INT CL³**
A61F 13/00 13/02 13/18
(52) Domestic classification
A5R PF PG PL
(56) Documents cited
GB 1560151
(58) Field of search
A5R
(71) Applicants
**Johnson & Johnson Baby Products Company,
501 George Street,
New Brunswick,
New Jersey,
United States of America.**
(72) Inventors
**Dennis Charles Holtman,
Shirley Ann Wade.**
(74) Agents
**Carpmaels & Ransford,
43, Bloomsbury Square,
London, WC1A 2RA.**

(54) **Sanitary napkin with two reservoirs**

(57) An absorbent structure comprises an absorbent cellulosic batt and a moisture-permeable cover. The absorbent batt contains two reservoirs each formed by compression of the fibers in a reservoir zone. The first reservoir is open toward the cover and the second reservoir is located below the first reservoir and contains particles of super-absorbent.

GB 2 087 240 A

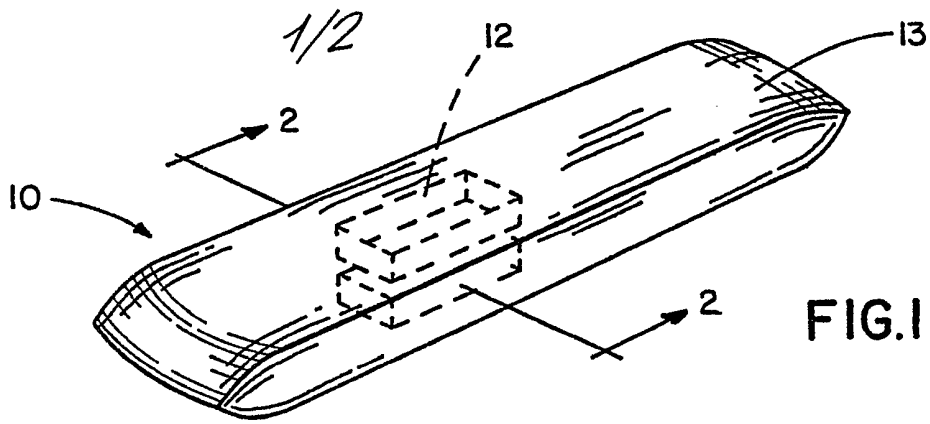

FIG. 1

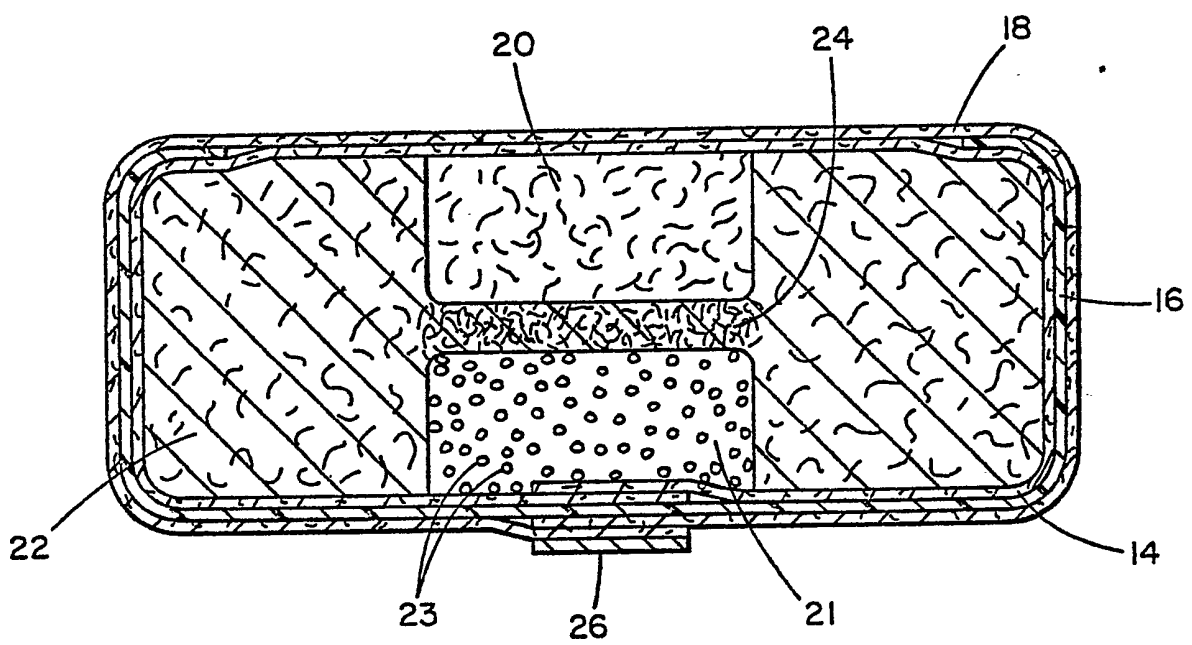

FIG. 2

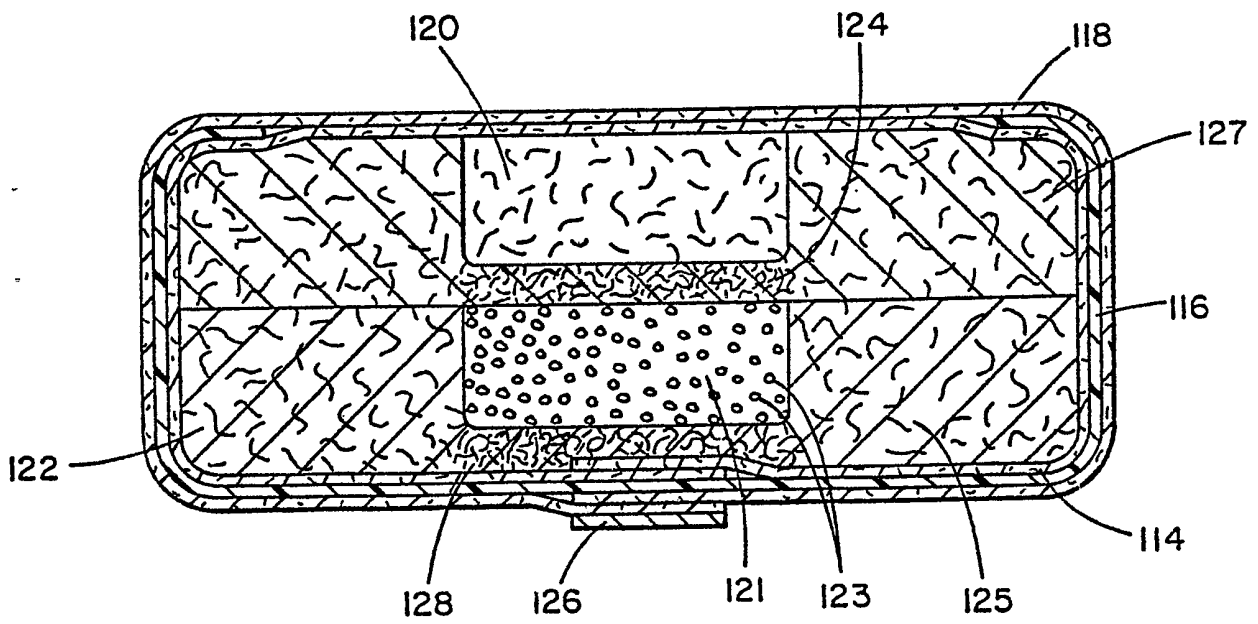

FIG. 2A

2/2

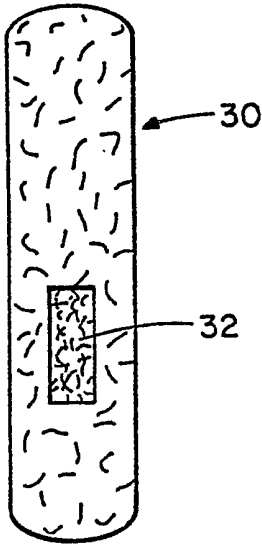

FIG. 3

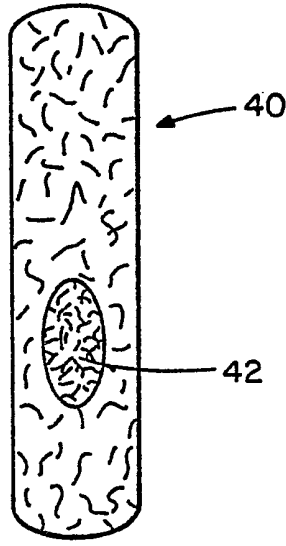

FIG. 4

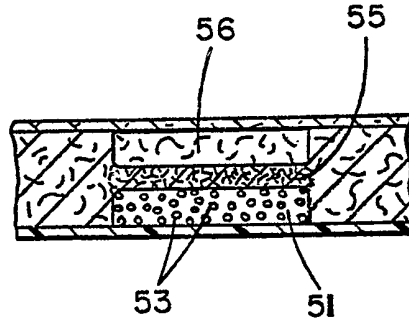

FIG. 5A

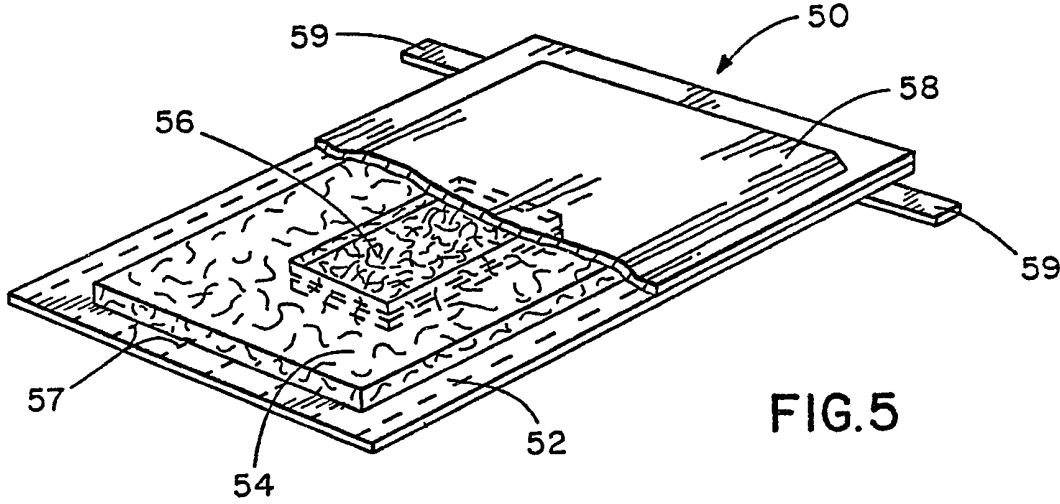

FIG. 5

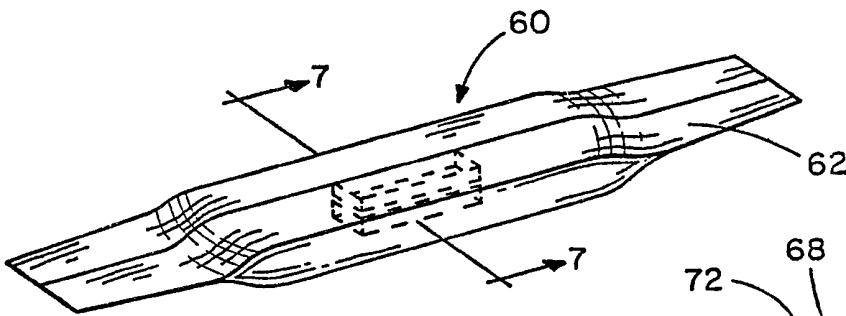

FIG. 6

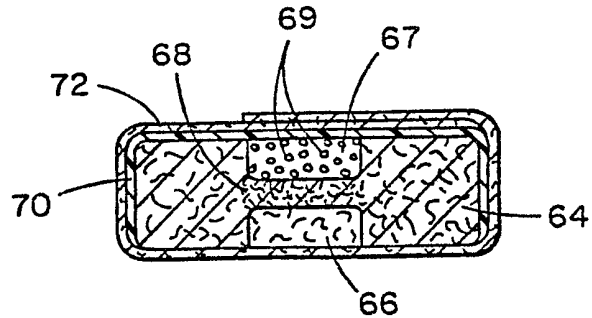

FIG. 7

SPECIFICATION

Absorbent structure containing superabsorbent5 *Background of the invention*

Disposable absorbent structures such as disposable diapers, sanitary napkins and incontinence pads have met with increased commercial acceptance in recent years, primarily because of their convenience.

10 Many different constructions have been proposed and used and some have met with wide-spread commercial success in spite of certain inadequacies in functional properties.

One of the most serious prior art problems has
15 been the inability to provide a suitable construction that can accept a large void of body fluids and retain a large quantity of body fluids. This is particularly true of the devices which have been developed for the adult incontinent whether the incontinent be
20 active and working or ill and bed-ridden. Various attempts have been made to provide special structures to absorb a large body fluid void. These include U. S. Patent 3,441,024 to H. J. Ralph, U. S. Patent 3,747,602 to H. J. Ralph, U. S. Patent 3,968,798 to H.
25 C. Hokanson and U. S. Patent 4,067,366 to R. L. Johnson. Other attempts have been made to provide structures which contain large quantities of body fluids. These include U. S. Patent 4,103,062 to G. M. Aberson et al, U. S. Patent 4,102,340 to F. K. Mesek et al and U. S. Patent 4,055,184 to Karami. While these
30 various constructions were designed to assist the adult incontinent and the infant, the problem of providing an overall absorbent structure which will both handle a full volume discharge without leakage and retain the discharge for a reasonable period of
35 time still remains.

When the incontinent is an adult, disposable structures generally have not accepted and held a full volume discharge of urine without leakage onto
40 clothing. Similarly, the sanitary napkins known in the art will not necessarily hold a full volume discharge of menstrual fluid. The present invention provides an absorbent structure which may be used as an infant diaper, an adult incontinent device, a sanitary
45 napkin, an incontinence pad, or the like.

* *Summary of the invention*

The present invention provides an absorbent structure to receive and contain body fluids comprising
50 a loosely-compacted, cellulosic fibrous batt having a moisture-impermeable backing sheet on one side and a fabric cover which covers at least the side of the absorbent batt opposite the backing sheet on the other side. The absorbent batt is provided
55 with two reservoirs, each of which has a capacity sufficient to hold at least 75% of the body fluid discharged in one second. The first reservoir is situated immediately below the fabric cover in the void zone. The second reservoir of substantially the
60 same size and shape of the first reservoir, is located below the first reservoir within the cellulosic fibrous batt. The reservoirs are formed by compression of the cellulosic fibers in the reservoir zone. The second reservoir contains deposited therein, a water-
65 swellable, water-insoluble absorbent composition.

The cellulosic fibrous batt containing the reservoirs may be incorporated in a disposable diaper such as for an infant or an adult diaper with a larger liquid holding capacity. Furthermore, the absorbent
70 structure may be incorporated in a sanitary napkin as well as in an incontinence pad. In each instance, the opening of the first reservoir is placed in the void zone allowing immediate acceptance by the reservoir of the body fluid discharge. Generally, the
75 discharge capacity of this reservoir will be at least 10 cc. The second reservoir is located below the first reservoir and is of substantially the same size and contains the superabsorbent.

The reservoirs are created by compression of the
80 loosely-compacted, cellulosic fibers in the reservoir area. The compaction may be carried out by application of pressure in the shape desired for the reservoir. This may be done by a stamping-type operation or by an embossing roll or the like.

85 *Brief description of the drawings*

Figure 1 is a perspective view of one embodiment of the present invention;

Figure 2 is a cross-sectional view taken along line
90 2--2 of the embodiment of *Figure 1*;

Figure 2A is a cross-sectional view taken along line 2--2 of another embodiment having the same exterior as that of *Figure 1*;

Figure 3 is a top view of another embodiment of
95 the present invention;

Figure 4 is a top view of still another embodiment of the present invention;

Figure 5 is a perspective view of a disposable diaper utilizing the absorbent structure of the pre-
100 sent invention;

Figure 6 is a perspective view of a sanitary napkin incorporating the absorbent structure of the present invention;

Figure 7 is a cross-sectional view taken along line
105 7--7 of *Figure 6*.

Detailed description of the invention

While this invention is susceptible of embodiment in many different forms, there is shown in the
110 drawings, and herein will be described in detail, preferred embodiments of the invention and modifications thereof. It is understood that the present disclosure is to be considered as an exemplification of the principles of the invention and is not intended to limit the invention to the embodiments illustrated. The scope of the invention will be pointed out in the appended claims.

Referring to the drawings and particularly to *Figure 1*, an absorbent structure 10 is provided with a reservoir area 12 lying below the cover 13. The cover is a moisture-permeable non-woven fabric. *Figure 2* shows the absorbent structure of *Figure 1* in cross-sectional view along line 2--2. The moisture-permeable exterior cover 18 completely wraps the
120 absorbent structure. A moisture barrier 16 which is a moisture-impermeable backing sheet covers the bottom area as well as both sides of the structure. Immediately adjacent the cellulosic batt 22 is a wrap of tissue 14. It may not be necessary to have a tissue
125 wrapping the cellulosic bat, but if the cellulosic batt

is quite thick, such as an inch or more, it may be desirable to provide a tissue wrap to assist with maintenance of the desired shape of the absorbent structure. The cellulosic batt 22 is provided with a first reservoir 20. Immediately below the first reservoir 20 is a densified fibrous region 24. Immediately below the densified fibrous region is the second reservoir 21. The second reservoir contains superabsorbent particles 23. The surface of the fibrous batt containing the opening of the first reservoir 20 is placed toward the wearer with the opening in the void zone. A release liner 26 is removed to expose adhesive so as to secure the structure to the underwear of the wearer.

Referring now to Figure 2A, a modification of the cross-section as shown in Figure 2 is depicted. In Figure 2A the reservoir area is altered in that the opening for the second reservoir 121 is immediately below the densified region 155 and a second densified region 128 is provided which is immediately below the second reservoir 121. The cellulosic batt is provided in two sections, the upper section 127 and the lower section 125. These two sections of absorbent batt are prepared and the reservoirs made in each of the sections. After placement of the superabsorbent particles 153 in the second reservoir 151, the cellulosic batts are superimposed so as to form the structure depicted. The combined cellulosic batts are wrapped in a tissue 114, part of which is surrounded by a moisture-impermeable barrier 116. The moisture-impermeable barrier surrounds the sides and bottom of the structure leaving the top portion open for entrance of the body fluid. A moisture-permeable cover or facing 118 surrounds the absorbent structure. A release liner 126 is removed to expose adhesive so as to secure the structure to the underwear of the wearer. The structure of Figure 2A performs in substantially the same manner as that in Figure 2. Preference of one embodiment over the other may be related to the nature of the body fluid to be absorbed and/or the processes available for the manufacture of the absorbent structure.

Figures 3 and 4 are top views of typical cellulosic batts used in the absorbent structure of the invention. The cellulosic batt 30 contains a reservoir 32 having the shape of a rectangle. The reservoir may be located nearer one end of the cellulosic batt 30, e.g., one-third of the way or between the center and end to assist in location in the void zone of the wearer. In Figure 4, a cellulosic batt 40 is provided with a reservoir 42 having an oval shape. Any desired shape and size may be used so long as the reservoir covers at least one square inch of surface and contains at least 10 cc in volume.

Referring now to Figure 5, a disposable diaper 50 is shown having a moisture-impermeable backing sheet 52. Superimposed upon the backing sheet 52 is a loosely-compacted, fibrous batt 54. The fibrous batt contains a first reservoir 56 situated immediately below a moisture-permeable facing 58 which is a non-woven fabric. The base of the reservoir 56 is a densified fibrous region 55. Immediately below the densified region 55 is a second reservoir 51 which reservoir contains particles of a water-swellable,

water-insoluble absorbent composition. Thus, in the structure defined, the body fluid discharged enters the reservoir 20 and is immediately absorbed by the densified region 24. The fluid then continues to pass through the densified region 24 into the reservoir 21, whereupon the superabsorbent particles 53 absorb large quantities of body fluid and retain the liquid within the absorbent structure 10. The facing 58 and backing 52 are adhered in the margin regions. In addition, glue lines 57 are used to secure the fibrous batt to the backing. Tape tabs 59 are provided to secure the diaper about the wearer.

Referring now to Figures 6 and 7, a sanitary napkin 60 is depicted. The cover 62 shown in Figure 6 is a moisture-permeable non-woven fabric. Figure 7 is a cross-sectional view taken along line 7--7 of Figure 6. A cellulosic fibrous batt 64 is partially surrounded by a moisture barrier 70. The entire structure is wrapped in the moisture-permeable cover 72. The cellulosic batt 64 contains a first reservoir 66. At the bottom of the reservoir is a densified fibrous area 68, beneath which is a second reservoir 67 containing superabsorbent particles 69. The dense fibrous area 68 is created when the reservoirs 66 and 67 are formed.

The loosely-compacted, cellulosic fibrous batt used in the absorbent structure of the present invention is formed from wood pulp fibers, rayon fibers, or cotton linters, or mixtures thereof. The batt is primarily held together by interfiber bonds requiring no added adhesive. In some instances, the batt may contain synthetic fusible fibers, such as polyethylene, polypropylene, and the like. The batt is a low density coherent web of loosely-compacted cellulosic fibers preferably comminuted wood pulp fibers in the form of so-called "fluff." The reservoirs in the cellulosic batt are created by compressing the portion of the batt which it is desired to become a reservoir. The compression should be sufficient to create a reservoir of sufficient depth to hold at least 10 cc. The base of the reservoir is a densified fibrous region wherein the fibers are compacted. The densified region quickly absorbs the body fluid and commences distribution of the fluid to other parts of the cellulosic batt. In addition, it may be desirable to provide a paper-like densified layer on the side of the batt opposite the reservoir which receives the original discharge. The paper-like densified layer is formed by a slight moistening of the surface of the batt followed by light compaction using the application of pressure. U. S. Patent 3,017,304, Burgeni, provides such a densified layer in a loosely-compacted cellulosic fibrous batt.

The cover or facing provided on the absorbent structure of the present invention is a non-woven fabric having a high degree of moisture-permeability. For example, the fabric may be polyester, polyethylene, polypropylene, nylon, rayon, or the like. Preferably, the fabric used for the cover is a lightweight fabric in the range of 0.3 - 5.0 oz/sq. yd. and with a density less than 0.3 gms/cc. The most suitable fabrics have unusually high elongation, loft, softness and drape characteristics. Though the cover is moisture-permeable, it is preferably of the type which after permeation of the moisture, prevents

strike-back of the body fluid when the absorbent structure is approaching saturation.

The body of the cellulosic fibrous batt is substantially more wettable than the cover and tends to draw liquid away from the facing layer. Thus the void occurs and the cover is permeated and the liquid deposited in the reservoir. The individual fibers of the batt are extremely wettable and thus draw liquid into the fibrous batt. The base of the reservoir is a densified fibrous region wherein the capillary radius is quite small. Thus the capillary pressure is increased and the liquid is rapidly distributed to portions of the cellulosic batt. The densified fibrous region at the base of the reservoir provides the maximum capillary pressure because it combines the very low contact angle of the fibers of the batt with the high density of the densified fibers.

The individual fibers of the batt are extremely wettable, generally having liquid-fiber contact angles below about 15° and approaching zero in the optimum embodiment. The wickability or preferential absorptivity of the body of the batt for water is limited, however, by its low density which results in large effective capillary radius for the capillaries between adjacent fibers.

The pressure causing a liquid to enter a cylindrical capillary is expressed by the equation

$$P = \frac{2v \cos \theta}{r}$$

wherein

P is the capillary pressure,
v is the surface tension of the liquid,
θ is the liquid-fiber contact angle, and
r is the capillary radius.

With a given liquid, the pressure (capillary force) increases with the cosine of the liquid-fiber contact angle (reaching a maximum where the angle is zero) and increases with narrower capillary radii so that narrower capillaries will draw liquid from wider ones.

The relative wickability between the cover layer and the body of the fibrous batt is affected by both the relative densities of the layers and the relative wettability of the individual fibers in each layer. The individual fibers of the batt have substantially smaller liquid-fiber contact angles than those of the cover layer overcoming the density difference and providing a substantial overall increase in capillary pressure to absorb liquid into the body of the batt.

A densified fiber layer such as that at the base of the reservoir provides the maximum capillary pressure because it combines the very low contact angle of the fibers of the batt with the high density (small capillary radius) of the densified fibers.

Thus when urine is voided into an area in the cover layer, it partially wets a small portion of the cover layer and is passed through the cover layer almost instantaneously to the first reservoir. In the first reservoir, the liquid comes into contact with the body of the batt and the densified region surrounding the reservoir. It is preferentially absorbed into the densified region because of its small capillary

structure and then into the body of the batt because of the enhanced wettability of the walls of the reservoir. The body fluid then passes through the densified region and into the second reservoir whereupon the superabsorbent particles begin their absorption of the liquid. The absorbent structure performs in the same manner whether the body fluid is urine, a menstrual fluid, or other liquid exudate.

The superabsorbent particles are generally a dry solid water-swellable, water-insoluble absorbent composition such as an ionic complex of a water-soluble anionic polyelectrolyte and a polyvalent metal cation. Typical superabsorbent compositions are illustrated in U. S. Patent 4,090,013 to S. H. Ganslaw et al and U. S. Patent 4,043,952 to S. H. Ganslaw et al. The superabsorbent may be in the form of individual particles or strips of film to which superabsorbent is adhered or other known superabsorbent compositions. The superabsorbent may be affixed to the base of the superabsorbent reservoir or may simply lie independently within the reservoir.

It will be understood by those skilled in the art that variations and modifications of the specific embodiments described above may be employed without departing from the spirit and scope of the invention as defined in the appended claims.

CLAIMS

1. An absorbent structure, suitable for absorption of body fluids, comprising a moisture-impermeable backing sheet; an absorbent, loosely-compacted cellulosic fibrous batt, superimposed on said backing sheet; and a moisture-permeable fabric cover, covering at least the side of said absorbent batt opposite said backing sheet, said absorbent batt being provided with two reservoirs, each having a capacity sufficient to hold at least 75% of the body fluid discharged in one second, the first reservoir being situated immediately below the moisture-permeable fabric cover in the void zone and being formed by compression of the cellulosic fibrous batt, the second reservoir being of substantially the same size as the first reservoir and being located below the first reservoir within the cellulosic fibrous batt, the second reservoir being formed by compression of the cellulosic fibers in the reservoir zone, said second reservoir containing deposited therein a water-swellable, water-insoluble absorbent composition.

2. The absorbent structure of Claim 1 wherein each reservoir has a capacity of at least 10 cc.

3. The absorbent structure of Claim 1 wherein the base of each reservoir is a densified region of the fibers of the fibrous batt.

4. The absorbent structure of Claim 3 wherein the opening of the second reservoir is located immediately adjacent the densified region of the fibers of the base of the first reservoir.

5. The absorbent structure of Claim 3 wherein the opening of the second reservoir is located immediately adjacent the backing sheet.

6. The absorbent structure of Claim 1 wherein the capacity of each of the reservoirs is sufficient to

hold at least 90% of the body fluid discharged in one second.

7. An adult incontinence device substantially rectangular in shape comprising a moisture-impermeable backing sheet; an absorbent loosely-compacted cellulosic fibrous batt superimposed on said backing sheet; and a moisture-permeable fabric cover, covering at least the side of said absorbent batt opposite said backing sheet, said absorbent batt being provided with two reservoirs each covering at least one square inch of the surface of the batt and each having a capacity of at least 10 cc, a first reservoir being situated in the void zone immediately beneath the moisture-permeable fabric cover and the second reservoir being of substantially the same size and shape of the first reservoir and being located below the first reservoir within the cellulosic batt, each reservoir being formed by compression of the cellulosic fibrous batt, said second reservoir containing deposited therein a water-swella-ble, water-insoluble absorbent composition.

8. The adult incontinence device of Claim 7 wherein said backing sheet is provided with an adhesive strip for securement of the device when worn.

9. A disposable diaper comprising a moisture-impermeable backing sheet; an absorbent, loosely-compacted, cellulosic fibrous batt, superimposed on said backing sheet; and a moisture-permeable facing superimposed on the side of the fibrous batt opposite said backing sheet, said absorbent batt being provided with two reservoirs each having a capacity sufficient to hold at least 75% of the body fluid discharged in one second, the first reservoir being situated in the void zone immediately below the facing, the second reservoir being of substantially the same size and shape of the first reservoir and being located below the first reservoir said second reservoir containing deposited therein a water-swella-ble, water-insoluble absorbent composition, each reservoir being formed by compression of the fibrous batt.

10. The disposable diaper of Claim 9 wherein each reservoir has as its base a densified fibrous region and has a capacity of at least 10 cc.

11. A sanitary napkin comprising a moisture-permeable outer layer containing an absorbent loosely-compacted cellulosic fibrous batt, said absorbent batt being provided with two reservoirs each having a capacity sufficient to hold at least 75% of the body fluid discharged in one second, a first reservoir being situated immediately below the moisture-permeable outer layer, the second reservoir being of substantially the same size and shape of the first reservoir and being located below the first reservoir, each reservoir being formed by compression of the fibrous batt.

12. The sanitary napkin of Claim 11 wherein the base of each reservoir is a densified region of the fibers of the fibrous batt.

13. An absorbent structure as claimed in claim 1, substantially as described with reference to Figures 1-4 of the accompanying drawings.

14. A disposable diaper as claimed in claim 9, substantially as described with reference to Figure 5

of the accompanying drawings.

15. A sanitary napkin as claimed in claim 11, substantially as described with reference to Figures 6 and 7 of the accompanying drawings.

Printed for Her Majesty's Stationery Office, by Croydon Printing Company Limited, Croydon, Surrey, 1982.
Published by The Patent Office, 25 Southampton Buildings, London, WC2A 1AY, from which copies may be obtained.