



US 20050127152A1

(19) **United States**

(12) **Patent Application Publication**
McHaney

(10) **Pub. No.: US 2005/0127152 A1**

(43) **Pub. Date: Jun. 16, 2005**

(54) **LID FOR PACKING BOX WITH DISPLAY FEATURE**

Publication Classification

(76) Inventor: **Blair C. McHaney**, Wenatchee, WA
(US)

(51) **Int. Cl.**⁷ **B65D 43/02**

(52) **U.S. Cl.** **229/232**

Correspondence Address:
VENABLE, BAETJER, HOWARD AND CIVILETTI, LLP
P.O. BOX 34385
WASHINGTON, DC 20043-9998 (US)

(57) **ABSTRACT**

A lid having a front portion, a rear portion, a top portion, a right side portion coupled to said front, rear, and top portions, a left side portion coupled to said front, rear, and top portions, and a display portion integrated with said top portion and said front portion. The display portion includes first and second sections, a hinge coupled to the first and second sections, and a flap coupled to the first portion. The display panel is capable of being partially separated from the lid and secured to the rear portion.

(21) Appl. No.: **10/993,150**

(22) Filed: **Nov. 22, 2004**

Related U.S. Application Data

(60) Provisional application No. 60/523,669, filed on Nov. 21, 2003.

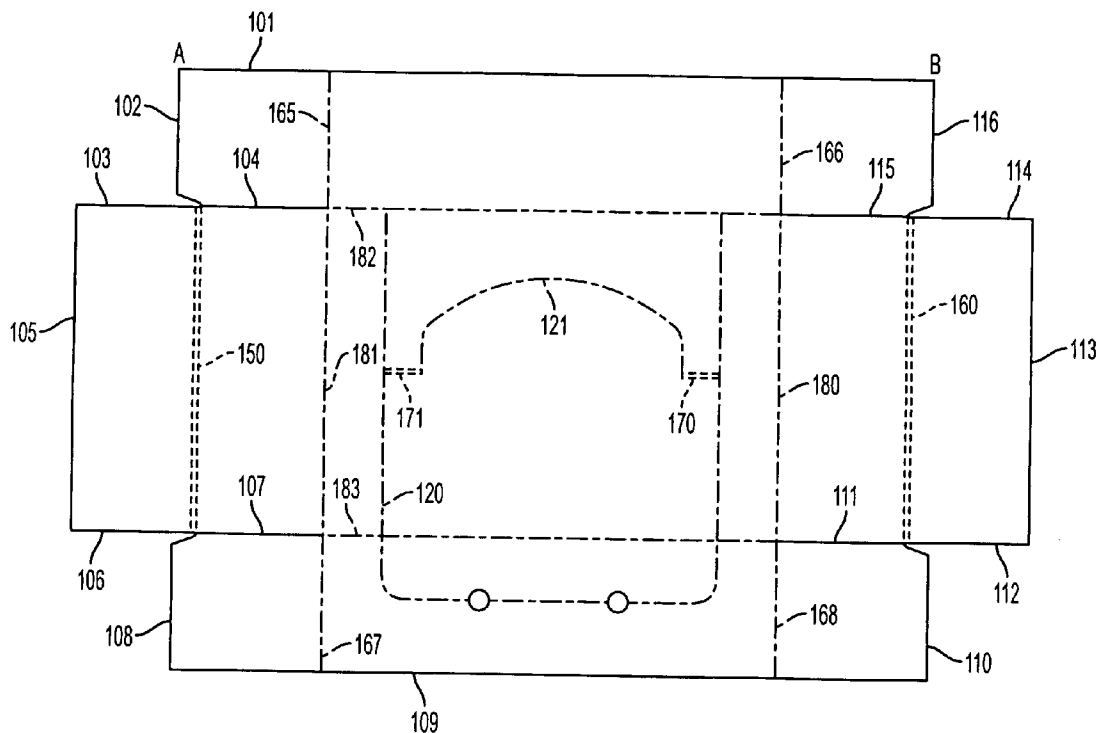

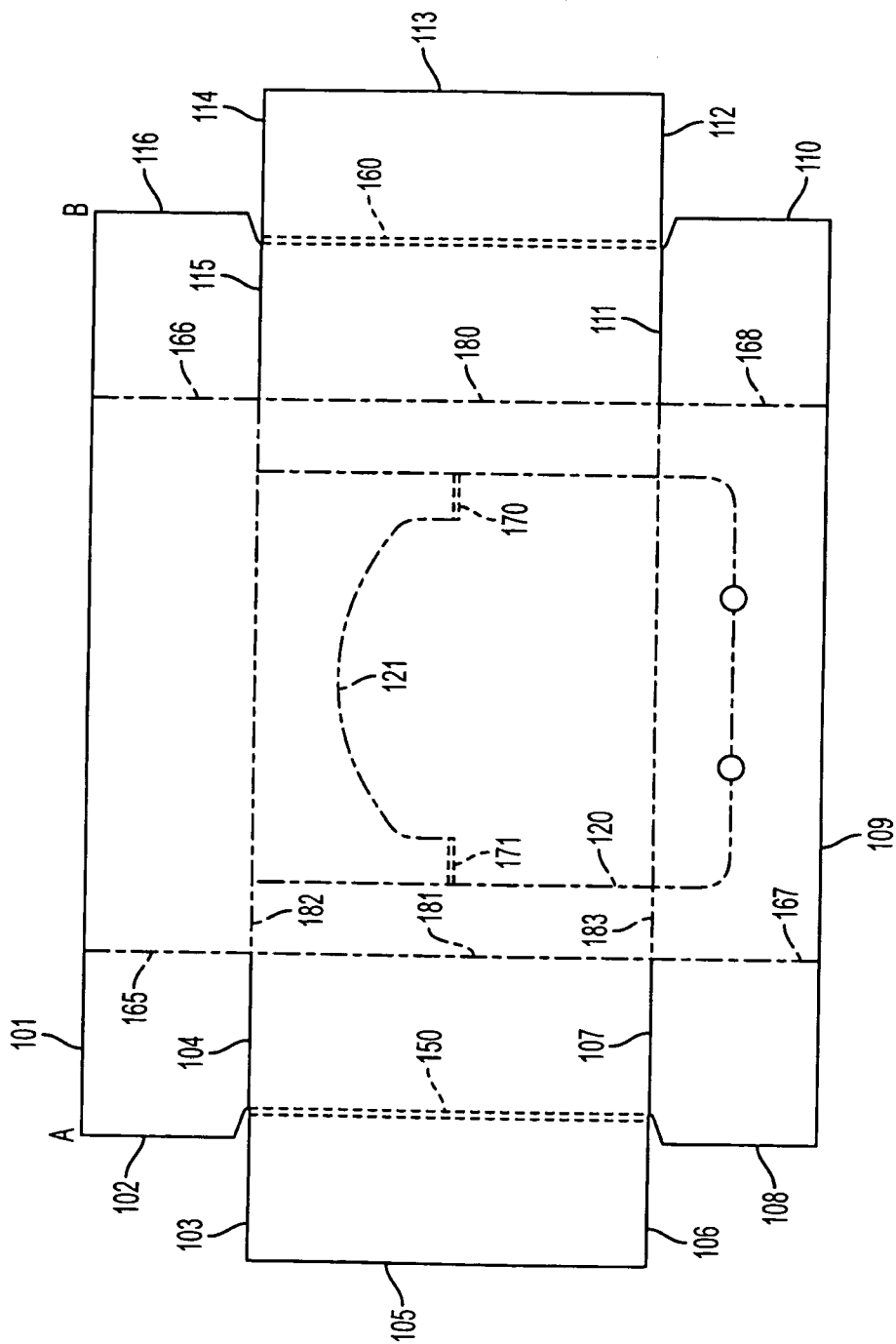

FIG. 1

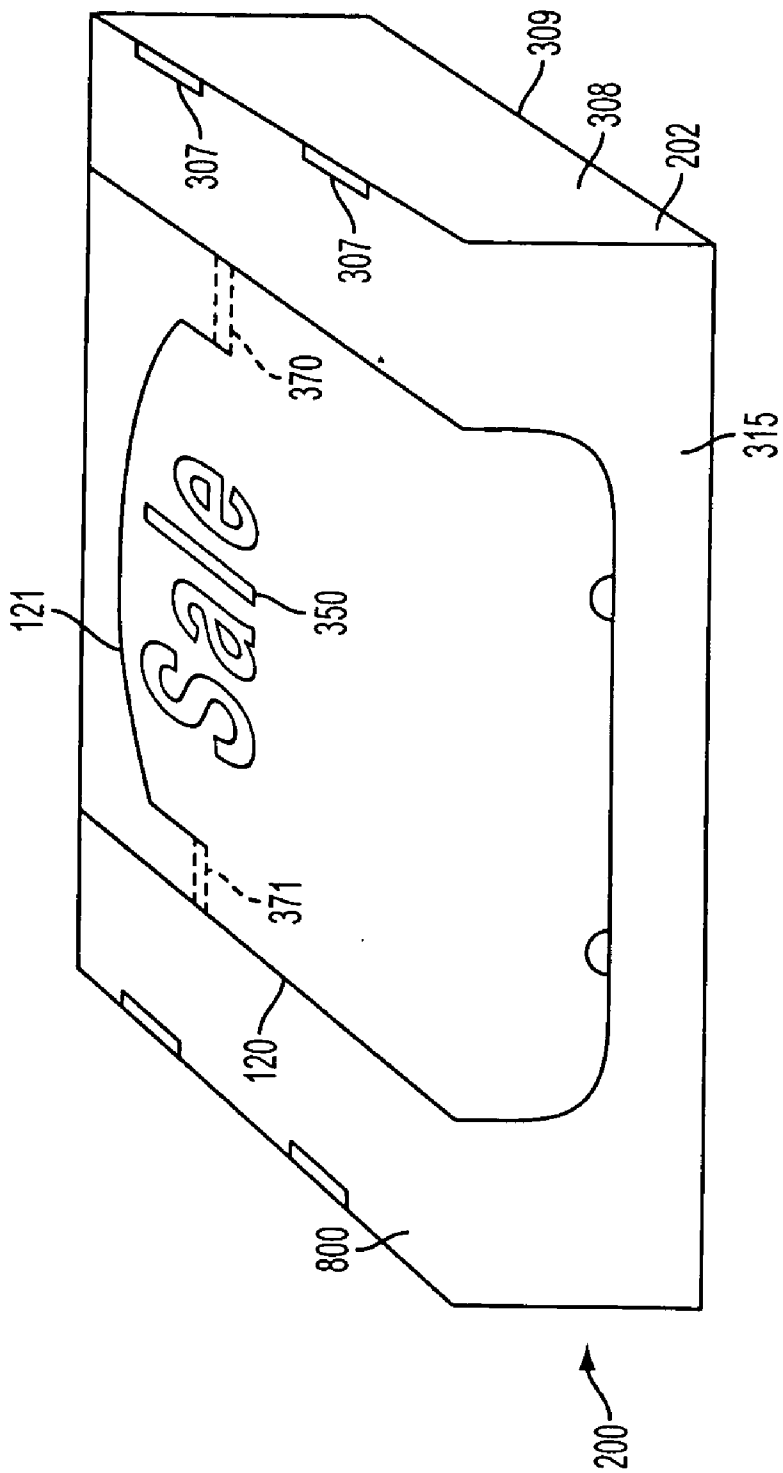

FIG. 2

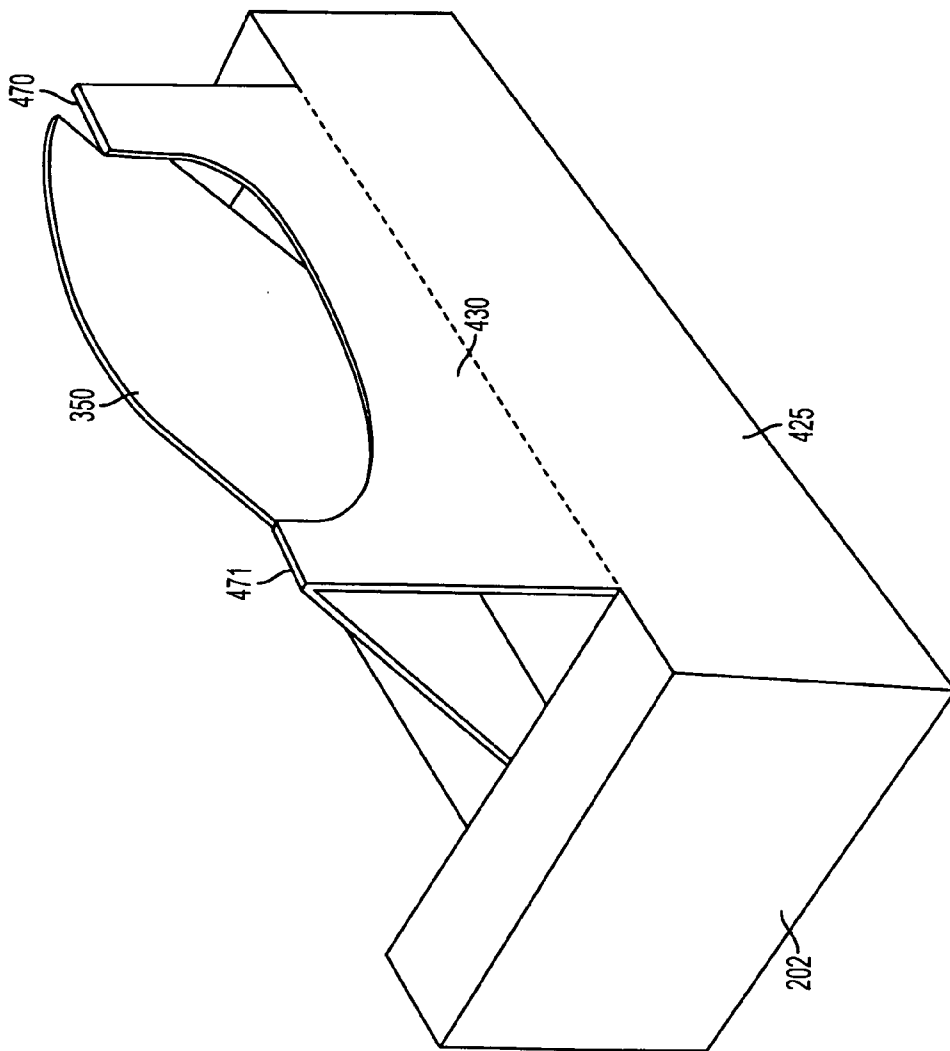

FIG. 3

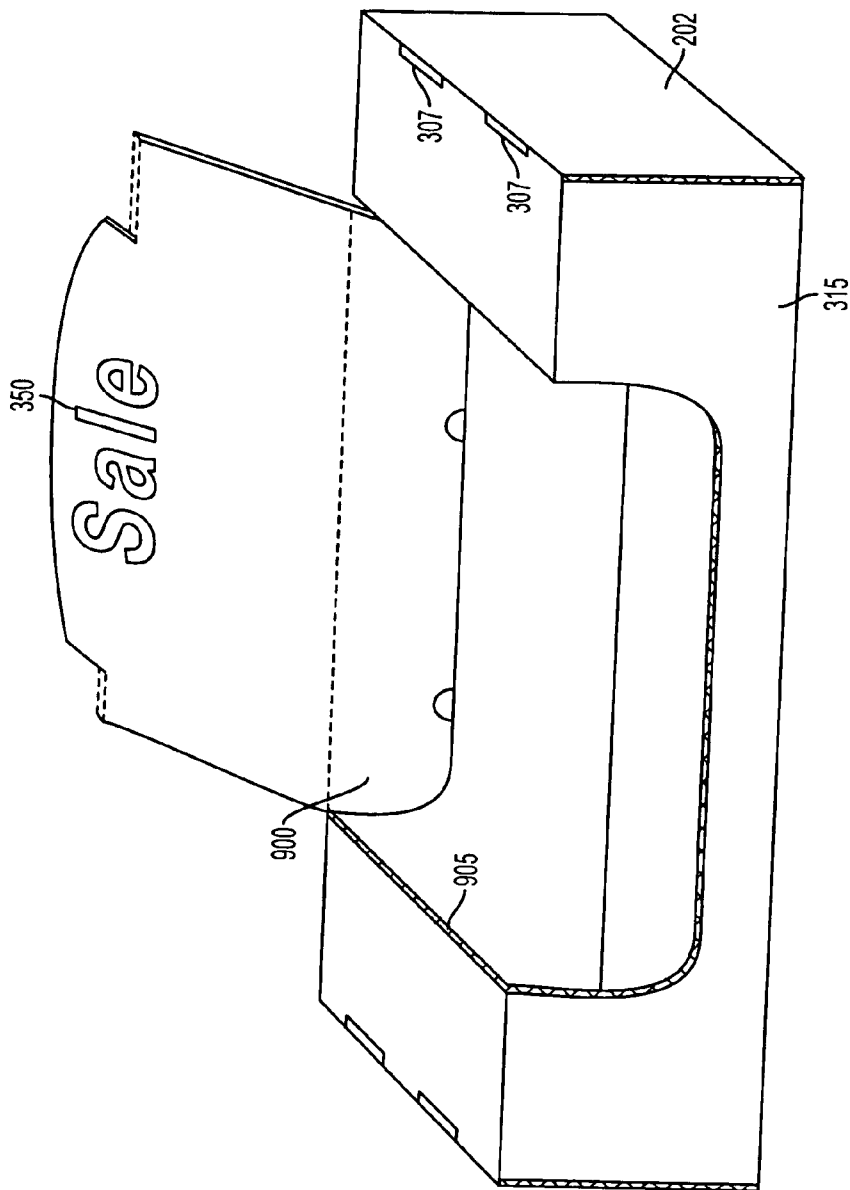

FIG. 4

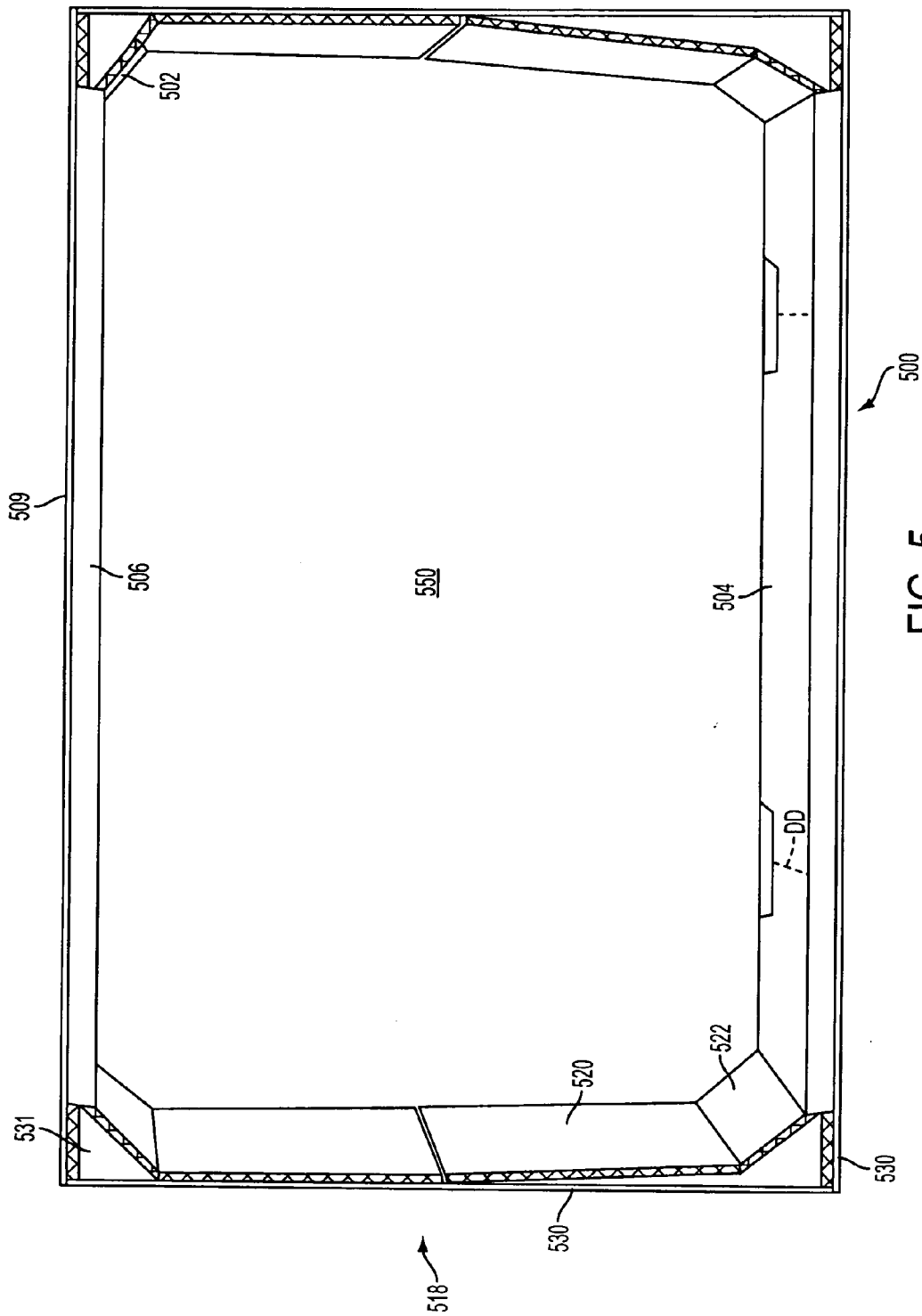

FIG. 5

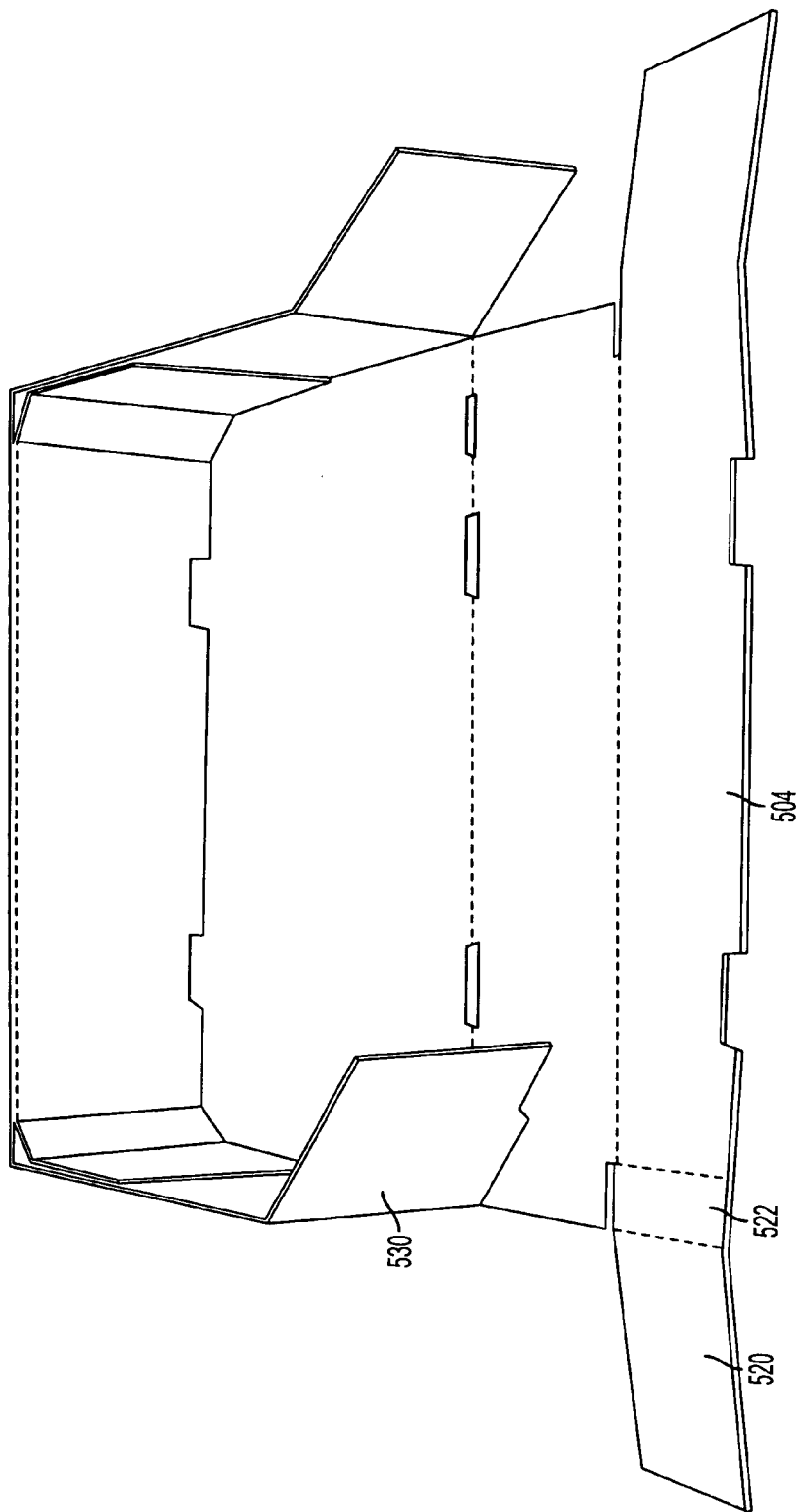
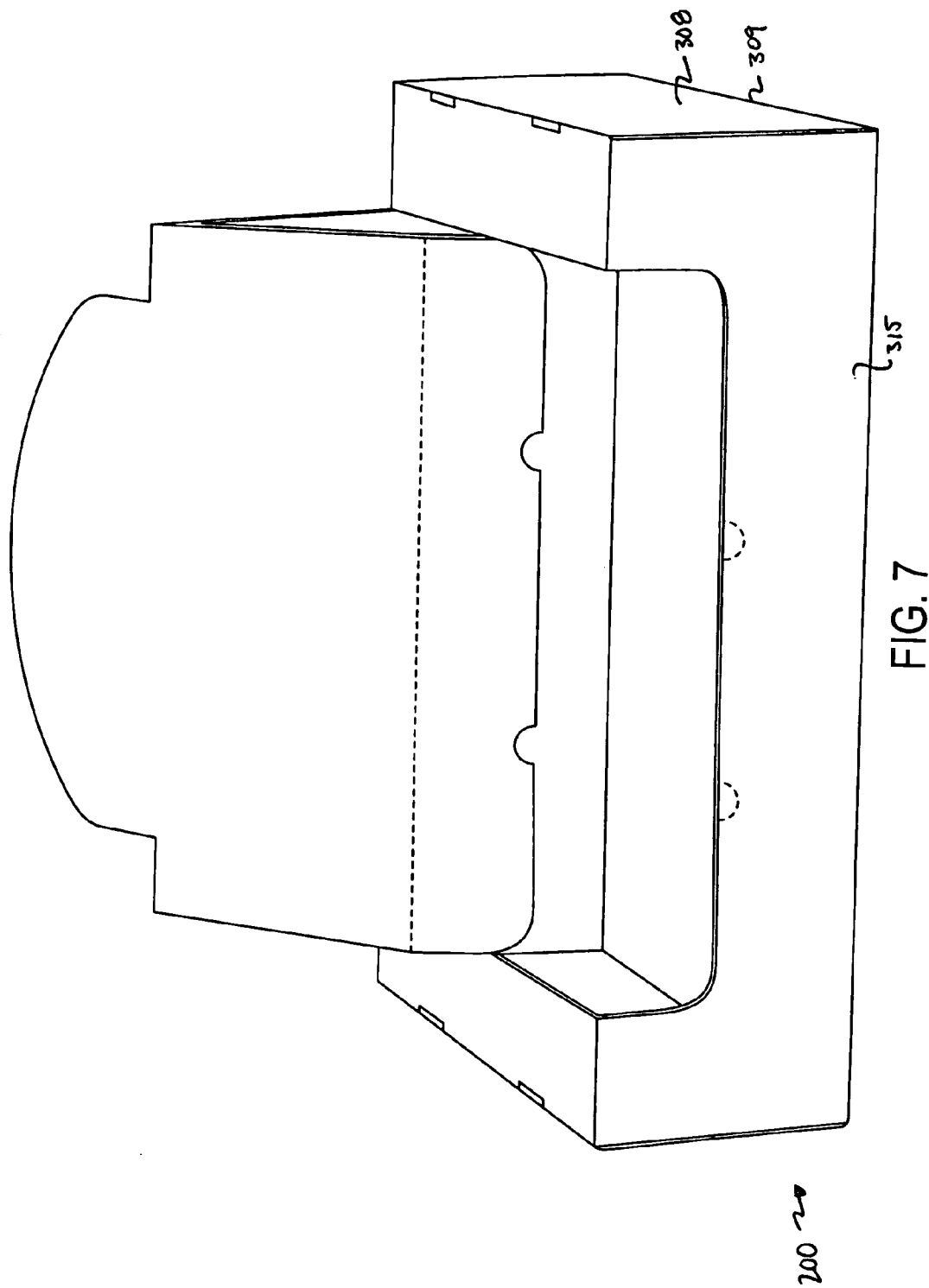

FIG. 6



LID FOR PACKING BOX WITH DISPLAY FEATURE

BACKGROUND OF THE INVENTION

[0001] 1. Field of the Invention

[0002] The present invention relates to an improvement for boxes and more particularly, for those boxes which also serve as display containers for the goods shipped therein in a retail environment.

[0003] 2. Related Art

[0004] Embodiments of the present invention are particularly suitable for a conventional "Euro" box that is now commonly used to ship produce such as apples. The "Euro" box has its own structure and does not require a lid for additional strength. As discussed herein, these boxes have reinforced corners that allow the boxes to be stacked on top of one another without damaging the boxes or the materials contained therein.

[0005] Conventionally, when a retail store receives produce in boxes from a wholesaler, the fruit is unpacked and set in a display. Typically, produce is put onto display racks, produce coolers, bags, bins or trays and the boxes are then discarded. While the display of goods within a shipping box is not novel, there is a need to provide improved display conditions wherein information regarding the product is conveniently provided, and can be easily set up so that it is accessible to a prospective purchaser. Preferably, this information is provided directly adjacent or in close proximity with the goods so that the information is convenient and the goods can be inspected with reference to the information.

BRIEF SUMMARY OF THE INVENTION

[0006] Exemplary embodiments of the invention provide a lid for displaying the contents within a box. In one embodiment, a lid having a front portion, a rear portion, a top portion, a right side portion coupled to said front, rear, and top portions, a left side portion coupled to said front, rear, and top portions, and a display portion integrated with said top portion and said front portion is provided. In such an embodiment, the display portion includes first and second sections, a hinge coupled to the first and second sections, and a flap coupled to the first portion. The display portion is also capable of being partially separated from the lid and secured to the rear portion. Such a lid may be resistant to toploading forces.

[0007] In a further embodiment of the invention, the display portion of the lid may include a display extension that extends beyond the hinge into the second section and is capable of being separated from the second section when said first section is folded into contact with said second section.

[0008] In still a further embodiment of the invention, the lid may be used to cover the contents of a box. The box may include a base, a front sidewall, a rear sidewall, a left sidewall coupled to said base, front sidewall, and rear sidewall, and a right sidewall coupled to said base, front sidewall, and rear sidewall. When the lid is placed on top of the box to cover the contents of the box, the lid, in combination with the box, may be resistant to toploading forces.

[0009] In yet another embodiment of the invention, the lid may be used to display the contents of a box. The box may include a base, a front sidewall, a rear sidewall, a left sidewall coupled to said base, front sidewall, and rear sidewall, and a right sidewall coupled to said base, front sidewall, and rear sidewall. When the lid is placed on top of the box to cover the contents of the box, the lid, in combination with the box, may be resistant to toploading forces.

BRIEF DESCRIPTION OF THE DRAWINGS

[0010] FIG. 1 is a top plan view of an exemplary embodiment of the cardboard from which the lid according to the invention is cut.

[0011] FIG. 2 is a perspective front view of the lid according to the invention showing the display panel in the closed position.

[0012] FIG. 3 is a rear perspective view of an exemplary embodiment of a lid according to the invention wherein the display panel is in an upright position.

[0013] FIG. 4 depicts a front perspective view of an exemplary embodiment of the lid aspect of the invention with the display panel in an upright position.

[0014] FIG. 5 depicts a top view of an exemplary embodiment of the bottom of a box used with the lid according to embodiments of the invention.

[0015] FIG. 6 depicts a front view of an exemplary embodiment of the bottom of a preferred box that is used in accordance with the invention in a partially disassembled condition.

[0016] FIG. 7 depicts a front view an exemplary embodiment of a lid according to the present invention.

DETAILED DESCRIPTION

[0017] Embodiments of the invention are discussed in detail below. In describing embodiments, specific terminology is employed for the sake of clarity. However, the invention is not intended to be limited to the specific terminology so selected. While specific exemplary embodiments are discussed, it should be understood that this is done for illustration purposes only. A person skilled in the relevant art will recognize that other components and configurations can be used without parting from the spirit and scope of the invention. All references cited herein are incorporated by reference as if each had been individually incorporated.

[0018] Exemplary embodiments of the present invention allow goods such as fruit to be displayed within the box it is shipped and provides a "message board" or "display panel" for providing information regarding the contents to be displayed to prospective customers. Providing such improvements allows an in-store display to be quickly and easily set up. In view of the ease of the set up and the added value associated with the lid according to embodiments of the invention, the retailer has additional incentives to purchase goods packed with the present invention. Further, the improved lid as described herein leads to increase the exposure and display of the products within a particular store, allows the origin of the products that are not traditionally individually labeled to be communicated to the purchaser, and provides more marketing and marketing

control by the wholesale seller. Increase exposure and improved display can lead to increased sales.

[0019] Because the lid of the Euro box is reinforced as described below, the lid of the box may be perforated without materially weakening the lid structure and without compromising the integrity of the structure of the box. The end result is a self-display package that takes little effort to execute or construct on behalf of the retail store. Because the produce companies do not typically have the man-power to send sales personnel into stores to ensure that point of sale marketing material is displayed correctly, the lid solves problems for both retailer and the wholesaler. If the seller wants to display the product without the lid, it can be easily removed.

[0020] Now referring to FIG. 1, a top view of the box lid 100 material prior to the cutting and folding step is shown. In an exemplary embodiment of the invention, corrugated cardboard is cut through on solid lines 101-116. Line 120 and line 121 are cut with perforations so that the line may be easily torn away at the point of sale. The dotted lines 150, 160, 170, and 171 depict areas where the cardboard is cut to facilitate folding.

[0021] After the box is cut from a blank, the box is assembled by folding the along the perforated lines 150 and 160 as well as along lines 165, 166, 167 and 168, and along top lines 180, 181, 182 and 183. The assembled lid is depicted in FIGS. 2, 34 and 7. In an exemplary embodiment of the invention, a piece of corrugated cardboard that is, for example, 29.01 inches wide and 51.09 inches long, is cut along those lines identified by solid lines. As seen in cutting plan as illustrated in FIG. 1, the cut 120 for the display lid stop at the rear top edge and the top forms a hinge at this location.

[0022] Now referring to FIG. 2, a box lid 200 is shown assembled with the top and integral display panel in the closed position. Gaps 307 received opposite tabs formed in the cardboard sidewalls to restrain the sidewalls in an upright position. In this regard, the sidewall 308 is formed of double thickness cardboard that has been folded along lower surface 309. The opposite sidewall is formed in the same matter. In the embodiment as shown in FIG. 2, the front sidewall 315 and rear sidewall 425 are formed from a panel extending from the top 800. The front sidewall 315 and rear sidewall 425 comprise a single ply sidewall. In this condition, the box is shipped and stored until it is time to access the contents.

[0023] As described above, when the box is cut, a number of perforations are also made to allow for ease of folding but do not result in a cut that allows separation by pulling the respective side apart. In other words enough cardboard remains along these lines to prevent the parts from being easily separated by mechanical tearing. For example, areas 370 and 371 are perforated to allow for ease of folding at that location. As best seen in FIG. 3, area 370 and 371 form shoulders 470 and 471 when the display panel 350 is in the upright position. Various through holes such as 307 may also be to received and retain opposite slots.

[0024] The pop up display panel 350 can be partially released from the top by separating the perforations along lines 121 and 120. The display panel is secured to the rear wall by rear section 430 where the two sections are in a

hinged arrangement. As best seen in FIG. 3, the display panel 350 is supported from the rear by section 430 that extends upward from the rear sidewall 425. As best seen in FIG. 4, when the front section 900 of display panel 350 is positioned parallel with the interior surface 905 of the rear wall 425, the weight of the display panel will cause the display to tilt rearward. The front panel 900 can be secured by tape or by sliding section 900 between the interior surface 905 of rear wall of the lid and the exterior surface 509 of rear wall 506 of the bottom box 500. In this regard, it should be understood that the lid fits outside the bottom of the box.

[0025] As discussed above, the box lid is particularly suitable for use in combination with a box bottom depicted in FIG. 5. FIG. 5 depicts a conventional produced box referred to as the "Euro" and is characterized by inter alia the reinforced cornered panels 502. These boxes have a three ply front wall 504 wherein the slot 530 extends within the two ply wall 504 to approximately location DD. The sidewall 518 is a two ply wall comprising side 530 that extends laterally from floor 550 and is stabilized in an upright position by slot 530 and slot 531.

[0026] FIG. 6 depicts the front of the box bottom 500 in an unassembled condition. Here one can see that lateral extensions 650 that, when assembled comprise interior panel of side wall 518 as well as the corner panel 522.

[0027] When the lid according to the invention is used in connection with the box, it is apparent that the lid 200 structures and bottom box 500 complement each other. In this regard, the lateral walls of the lid 202 consist of two layers and, when in association with the box positioned next to the bottom box 500 which has two sidewalls therefore providing a total of four layers. The front wall 504 and the rear walls 506 of the box bottom 500 which substantially comprise three layers (near the opposite end) are reinforced with a single layer by the front 315 and rear 425 of the lid. The lid has the same height at the box so both the lid and the box bottom will provide support to materials on top of the box.

[0028] When provided with a lid according the invention, multiple boxes may be stacked upon one another without crushing the bottom boxes because the lid as described above is resistant to toploading forces. While the middle of the box is somewhat structurally compromised by the perforations that create the display panel, this section of the box does not bear significant weight and therefore the box remains sturdy.

[0029] While printed matter can be provide directly on the cardboard from which the box is made to result with desired printed matter being located on the display panel, the display region can also received printed matter created by the retail establishment. For example a section may be left blank so that the retail can insert pricing information. While the top edge 121 of the display panel is depicted herein, this line may be made fanciful, such as in the outline of an apple, grapes etc.

[0030] The embodiments illustrated and discussed in this specification are intended only to teach those skilled in the art the best way known to the inventors to make and use the invention. Nothing in this specification should be considered as limiting the scope of the present invention. All examples presented are representative and non-limiting. The above-

described embodiments of the invention may be modified or varied, without departing from the invention, as appreciated by those skilled in the art in light of the above teachings. It is therefore to be understood that, within the scope of the claims and their equivalents, the invention may be practiced otherwise than as specifically described.

What is claimed is:

- 1. A lid, comprising:
 - a front portion;
 - a rear portion;
 - a top portion;
 - a right side portion coupled to said front, rear, and top portions;
 - a left side portion coupled to said front, rear, and top portions; and
 - a display portion integrated with said top portion and said front portion,
 wherein said display portion comprises first and second sections, a hinge coupled to said first and second sections, and a flap coupled to said first portion, and wherein said display panel is capable of being partially separated from the lid and secured to said rear portion.
- 2. The lid according to claim 1, wherein said front, rear, right side, left side, and display portions are composed of corrugated cardboard.
- 3. The lid according to claim 1, wherein said display portion is defined by a perforated boundary for facilitating the partial separation of said display portion from the lid.
- 4. The lid according to claim 1, wherein said hinge enables said first section to fold into contact with said second section.
- 5. The lid according to claim 1, wherein said first section includes a display extension that extends beyond said hinge into said second section and is capable of being separated from said second section when said first section is folded into contact with said second section.
- 6. The lid according to claim 1, wherein said front, rear, right side, left side, and display portions are resistant to toploading forces.
- 7. A box comprising:
 - a base;
 - a front sidewall;
 - a rear sidewall;
 - a left sidewall coupled to said base, front sidewall, and rear sidewall;

- a right sidewall coupled to said base, front sidewall, and rear sidewall; and
- a lid according to claim 1 for placing on said box to cover contents within said box and the height of the sidewalls of said lid is equal to the height of said sidewalls of said box plus the thickness of the top portion of said lid whereby the combination of said sidewalls of said box and said lid provide increased resistance to top loading forces.
- 8. The box according to claim 7, wherein said left and right sidewalls comprise two-ply sidewalls.
- 9. The box according to claim 7, further comprising:
 - reinforced corner panels positioned between said front sidewall and said left sidewall, said front sidewall and said right sidewall, said rear sidewall and said left sidewall, and said rear sidewall and said right sidewall.
- 10. The box according to claim 7, wherein said lid is resistant to toploading forces.
- 11. A box comprising:
 - a base;
 - a front sidewall;
 - a rear sidewall;
 - a left sidewall coupled to said base, front sidewall, and rear sidewall;
 - a right sidewall coupled to said base, front sidewall, and rear sidewall; and
 - a lid according to claim 4 for displaying contents within the box when said first section is folded into contact with said second section.
- 12. The box according to claim 11, wherein said left and right sidewalls comprise two-ply sidewalls.
- 13. The box according to claim 11, further comprising:
 - reinforced corner panels positioned between said front sidewall and said left sidewall, said front sidewall and said right sidewall, said rear sidewall and said left sidewall, and said rear sidewall and said right sidewall.
- 14. The box according to claim 11, wherein said lid is resistant to toploading forces.
- 15. The box according to claim 11, wherein said flap may be inserted between said rear sidewall and said rear portion when said lid is placed onto the box and when said first section is folded into contact with said second section.

* * * * *