



US00D822242S

(12) **United States Design Patent**  
**Lee et al.**

(10) **Patent No.:** **US D822,242 S**  
(45) **Date of Patent:** **\*\* Jul. 3, 2018**

(54) **HEADLIGHT FOR CARS**  
(71) Applicant: **HYUNDAI MOTOR COMPANY,**  
Seoul (KR)  
(72) Inventors: **Soon-Il Lee,** Seoul (KR); **Jung-Taik Hur,** Yongin-si (KR)  
(\*\*) Term: **15 Years**  
(21) Appl. No.: **35/502,534**  
(22) Filed: **Jan. 5, 2017**  
(80) **Hague Agreement Data**  
Int. Filing Date: **Jan. 5, 2017**  
Int. Reg. No.: **DM/094834**  
Int. Reg. Date: **Jan. 5, 2017**  
Int. Reg. Pub. Date: **Mar. 3, 2017**

(30) **Foreign Application Priority Data**  
Oct. 20, 2016 (KR) ..... 30-2016-0050279  
(51) **LOC (11) Cl.** ..... **26-06**  
(52) **U.S. Cl.**  
USPC ..... **D26/28**  
(58) **Field of Classification Search**  
USPC ..... D12/86, 90, 91, 92, 114, 163, 169, 171,  
D12/172, 173, 181, 190, 196, 197, 199,  
D12/400; D26/28-36  
CPC .. B62J 6/02; B62J 6/00; B60Q 3/0279; B60Q  
1/04; B60Q 1/0408; B60Q 1/0466; B60Q  
1/2653; B60Q 1/28; F21S 48/00; F21S  
48/10; F21S 48/115; F21S 48/1233; F21S  
48/1266; F21S 48/1388; F21S 48/2268  
See application file for complete search history.

(56) **References Cited**  
U.S. PATENT DOCUMENTS  
D528,231 S \* 9/2006 Ikeda ..... D26/28  
D529,208 S \* 9/2006 Ikeda ..... D26/28

D544,614 S *	6/2007	Markefka .....	D26/28
D545,980 S *	7/2007	Platto .....	D26/28
D658,321 S *	4/2012	Takeda .....	D26/28
D674,940 S *	1/2013	Lai .....	D26/28
D676,166 S *	2/2013	Lai .....	D26/28
D677,813 S *	3/2013	Hanaoka .....	D26/28
D706,471 S *	6/2014	Lai .....	D26/28
D707,865 S *	6/2014	Yoshida .....	D26/28
D718,893 S *	12/2014	Lai .....	D26/28
D720,870 S *	1/2015	Lim .....	D26/28
D721,450 S *	1/2015	Lai .....	D26/28
D739,578 S *	9/2015	Han .....	D26/28
D742,045 S *	10/2015	Futschik .....	D26/28
D746,495 S *	12/2015	Gorsten Schuenemann ..	D26/28
D747,821 S *	1/2016	Yoshida .....	D26/28
D761,463 S *	7/2016	Lai .....	D26/28
D761,986 S *	7/2016	Obatake .....	D26/28
D765,894 S *	9/2016	Lai .....	D26/28
D769,477 S *	10/2016	Gunnarson .....	D26/28
D779,090 S *	2/2017	Giolito .....	D26/28
9,676,320 B2 *	6/2017	Lyon .....	B60Q 1/0035
D796,715 S *	9/2017	Lin .....	D26/28
D797,332 S *	9/2017	Lin .....	D26/28
D801,564 S *	10/2017	Nakamura .....	D26/28
D801,567 S *	10/2017	Oh .....	D26/28

(Continued)

Primary Examiner — Darlington Ly

(57) **CLAIM**

The ornamental design for a headlight for cars, as shown and described.

**DESCRIPTION**

1. Headlight for cars
- 1.1 is a top, front, and left side perspective view of a headlight for cars showing our new design;
- 1.2 is a front elevation view thereof;
- 1.3 is a rear elevation view thereof;
- 1.4 is a left side elevation view thereof;
- 1.5 is a right side elevation view thereof;
- 1.6 is a top plan view thereof; and
- 1.7 is a bottom plan view thereof.

**1 Claim, 7 Drawing Sheets**

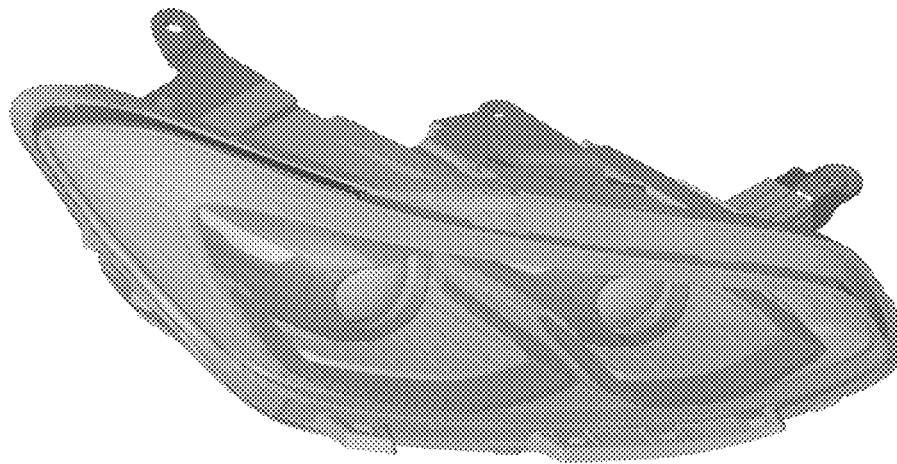

(56)

**References Cited**

U.S. PATENT DOCUMENTS

D802,181	S	*	11/2017	Cartabiano	.....	D26/28
D803,433	S	*	11/2017	Yang	.....	D26/28
D806,285	S	*	12/2017	Kawakami	.....	D26/28
D806,286	S	*	12/2017	Kawakami	.....	D26/28
2014/0192548	A1	*	7/2014	Kracker	.....	F21S 48/1159 362/538

\* cited by examiner

1.1

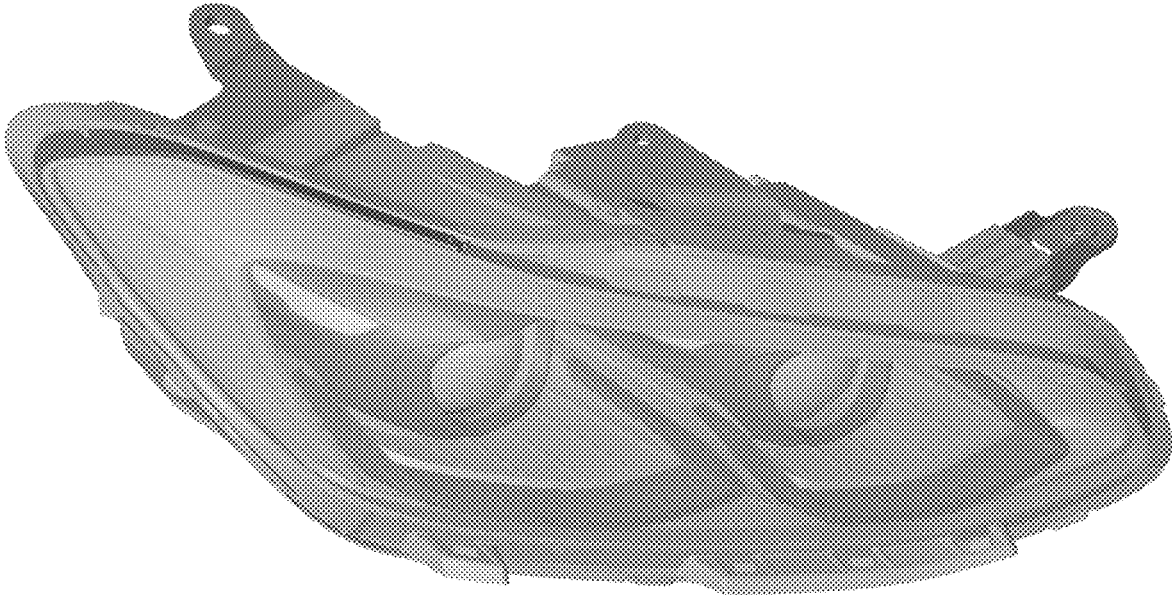

1.2

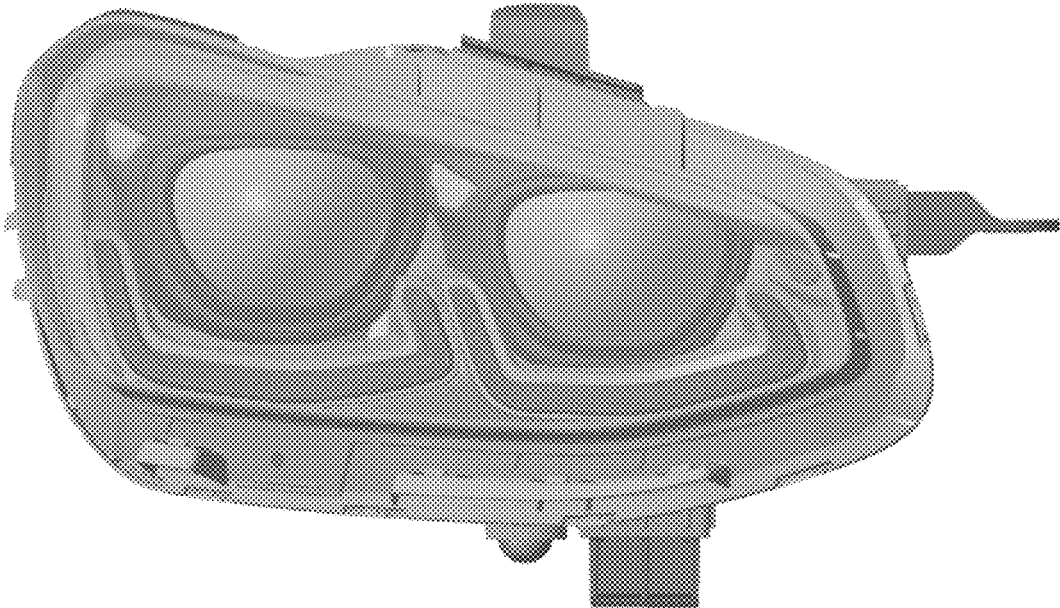

1.3

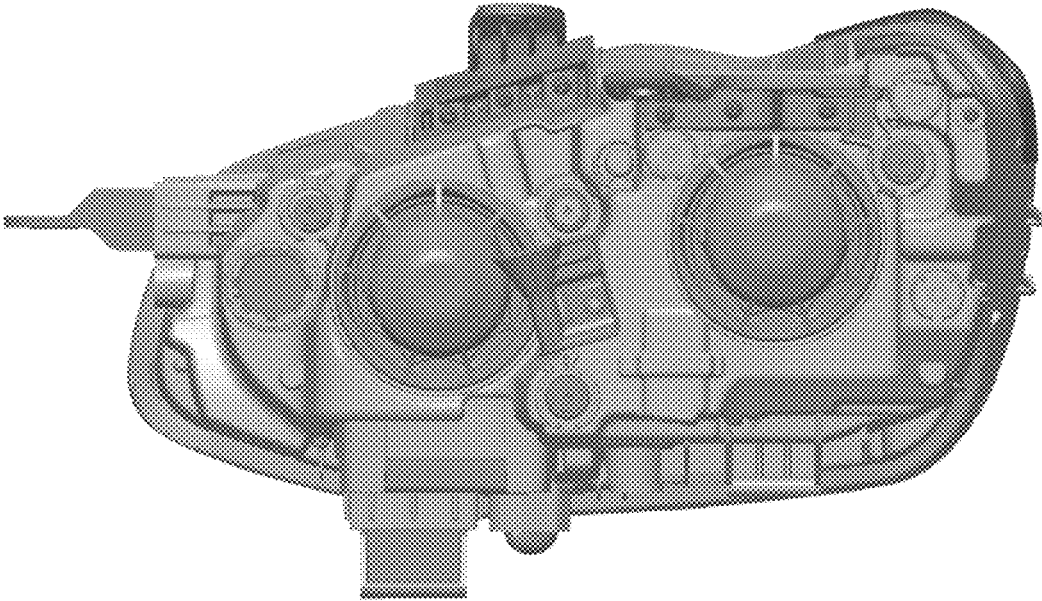

1.4

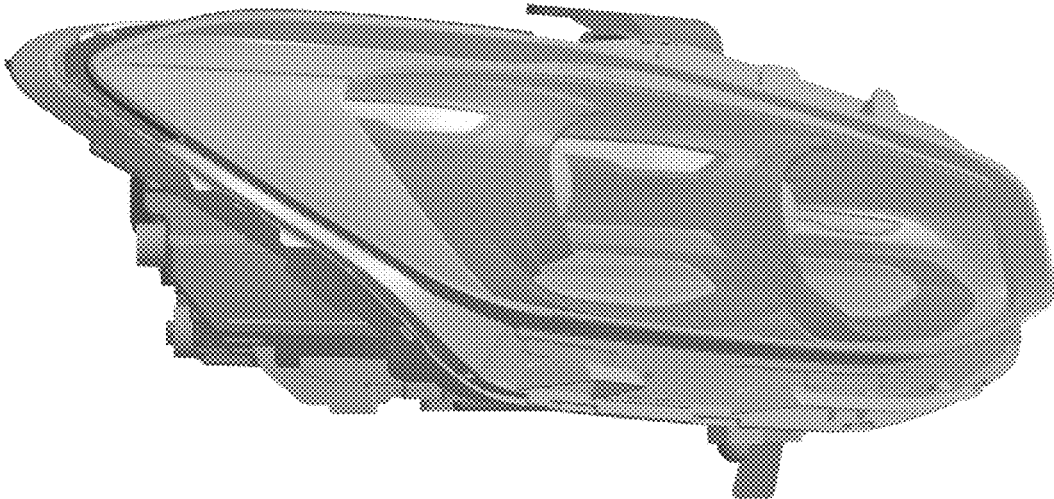

1.5

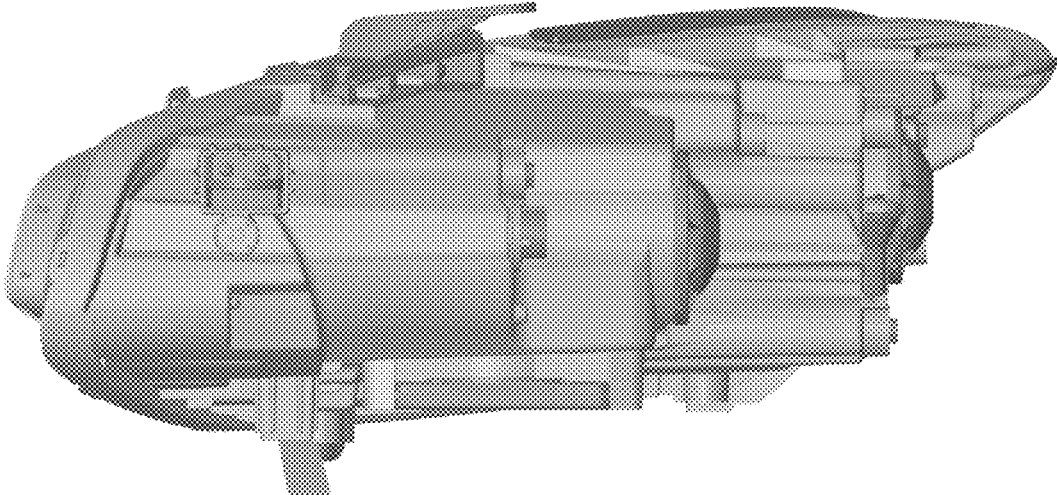

1.6

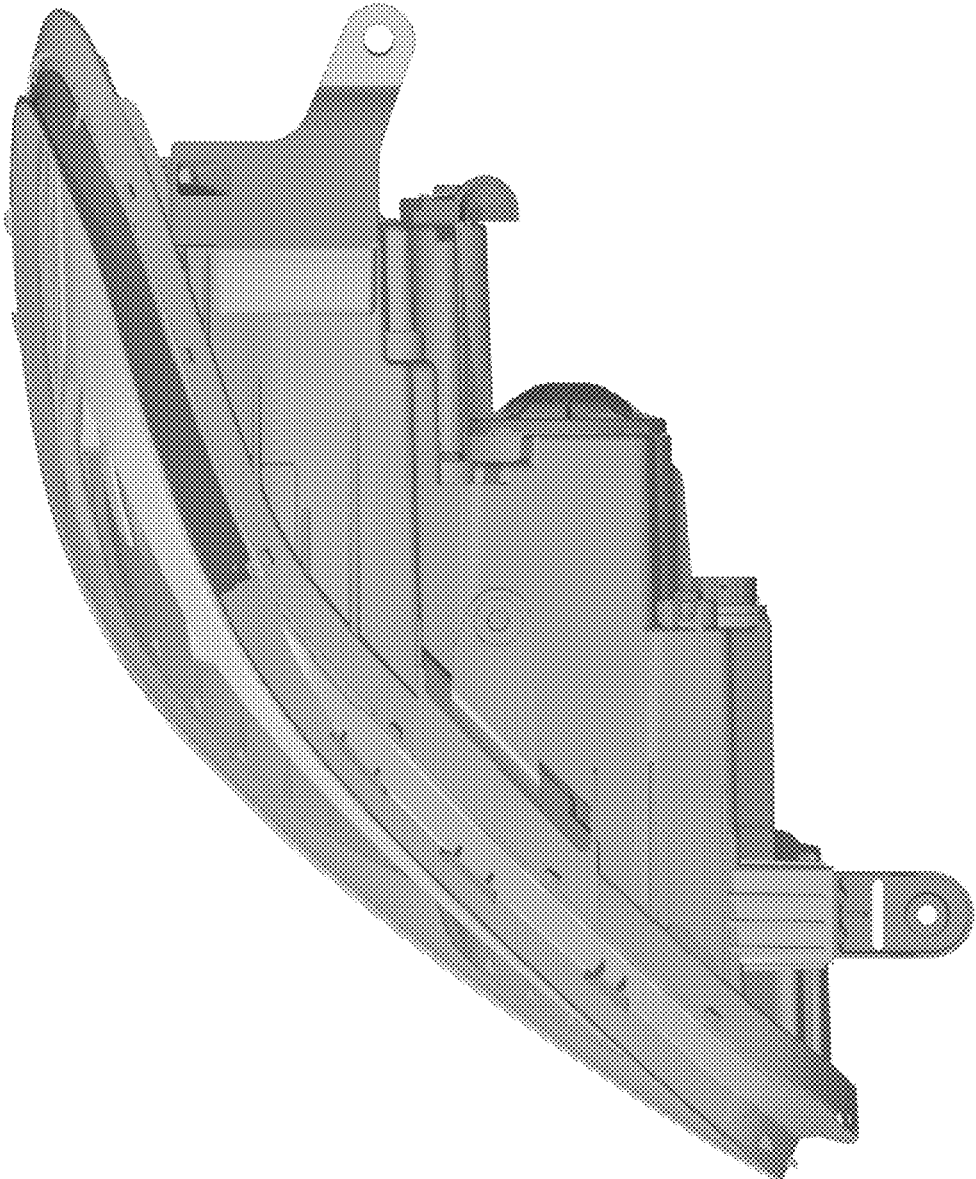



1.7

