

(21) Application No: 1222609.8

(22) Date of Filing: 14.12.2012

(71) Applicant(s):
BAE SYSTEMS plc
6 Carlton Gardens, LONDON, SW1Y 5AD,
United Kingdom

(72) Inventor(s):
Marcus Edward Clark
Michael Andrew Scott
James Eade

(74) Agent and/or Address for Service:
BAE SYSTEMS plc
P O Box 87, Group IP Department, Warwick House,
Farnborough Aerospace Centre, FARNBOROUGH,
Hants, GU14 6YU, United Kingdom

(51) INT CL:
H01Q 3/26 (2006.01) **G02B 6/36** (2006.01)
H04B 17/00 (2006.01)

(56) Documents Cited:
GB 2342505 A **GB 2145570 A**
US 6346910 B1 **US 6157343 A**
US 5493304 A **US 20060033655 A1**
US 20050140546 A1

(58) Field of Search:
INT CL **G02B, H01Q, H04B**
Other: **EPODOC, WPI, TXTE**

(54) Title of the Invention: **Improvements in and relating to antennas**
Abstract Title: **Rotating antenna array and rotary joint calibration system**

(57) An antenna system 1, or a method for calibrating an antenna system 1, comprises: generating an RF calibration signal 62 which is applied to an RF input port of one or more RF receiver units 4, not involving the antenna elements 3; measuring the response of the antenna system 1 to the calibration signal 62 and calculating the signal corrections and applying these signal corrections to subsequently received signals by the antenna and receiver system. The calibration system may be applied to a rotating antenna array involving modulated analogue optical signals being transmitted through an optical rotary joint 10 such that the calibration system corrects signal errors introduced by the said rotary joint during rotation over a 720° azimuth angle rotational range. The optical rotary joint 10 may have multiple optical channels transferred through a Dove or Abbe-Konig reversion prism. Mach-Zehnder (MZ) electrical-optical signal modulators 6 and opto-electrical converters 14 may be used. The antenna system may include analogue and digital signal processing and analogue to digital converter arrangements.

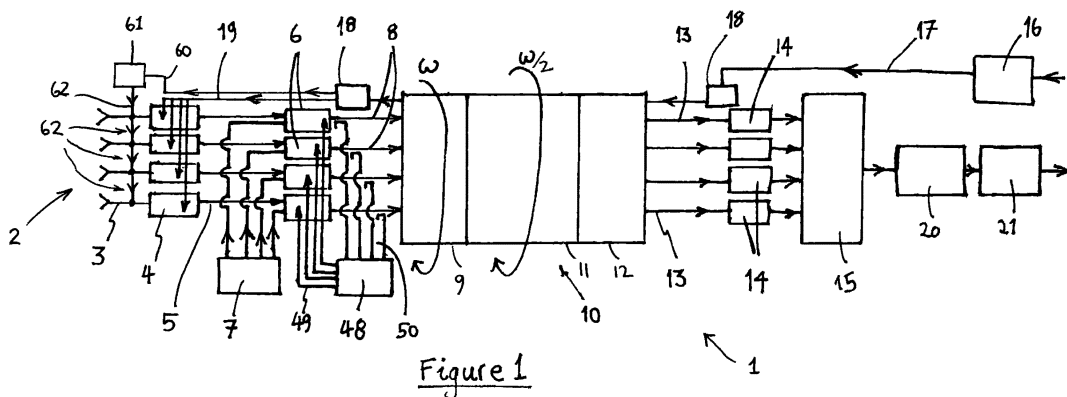

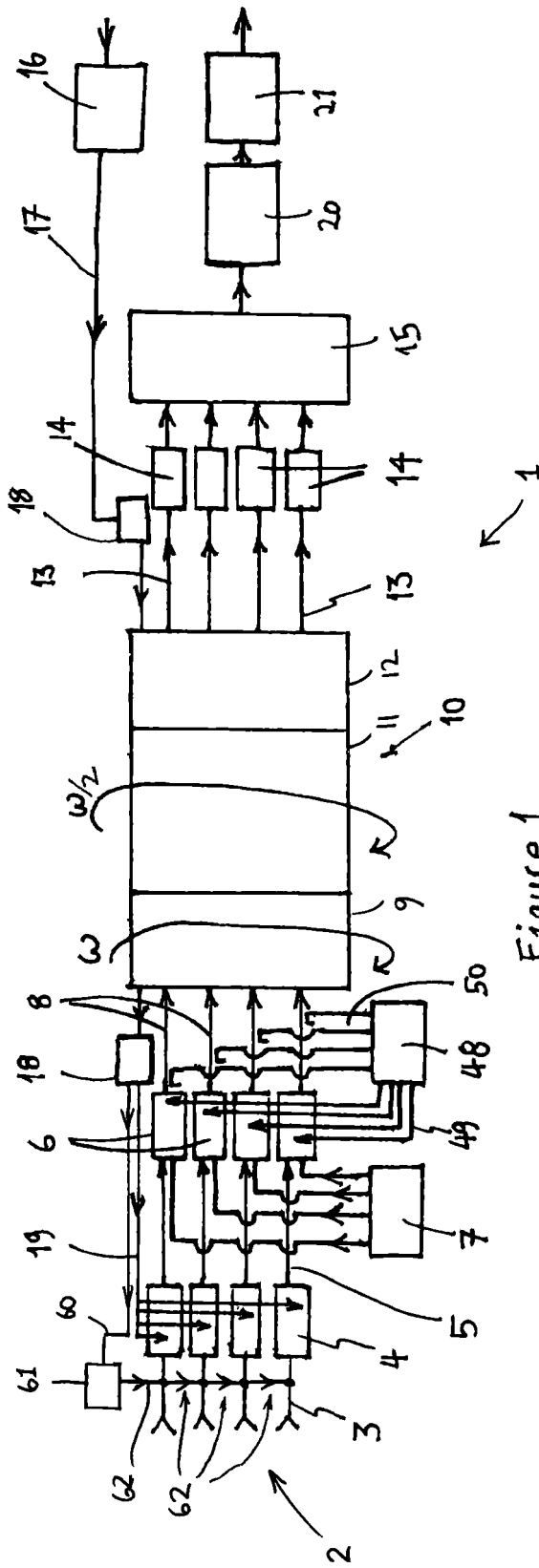

Figure 1

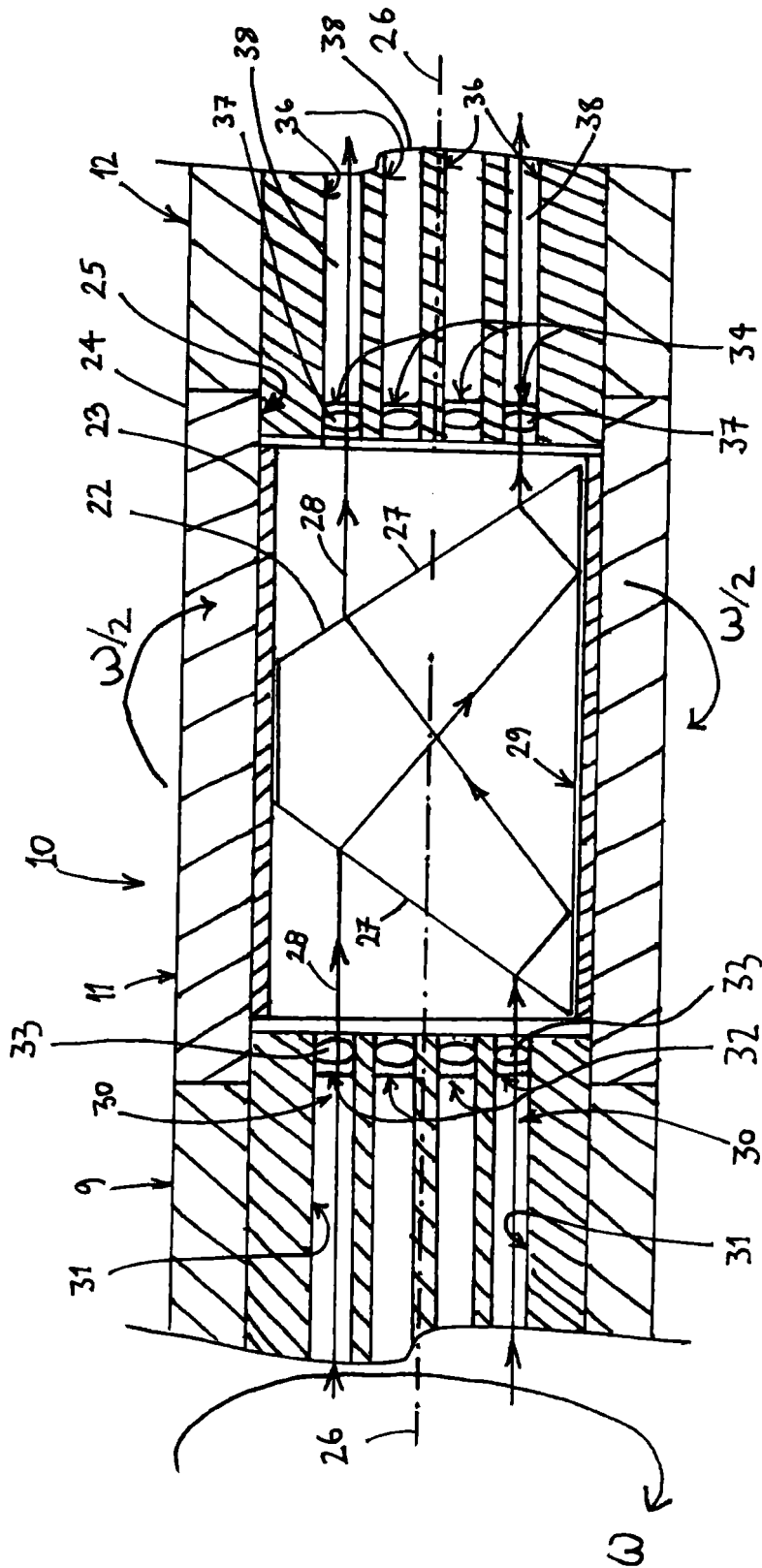

Figure 2

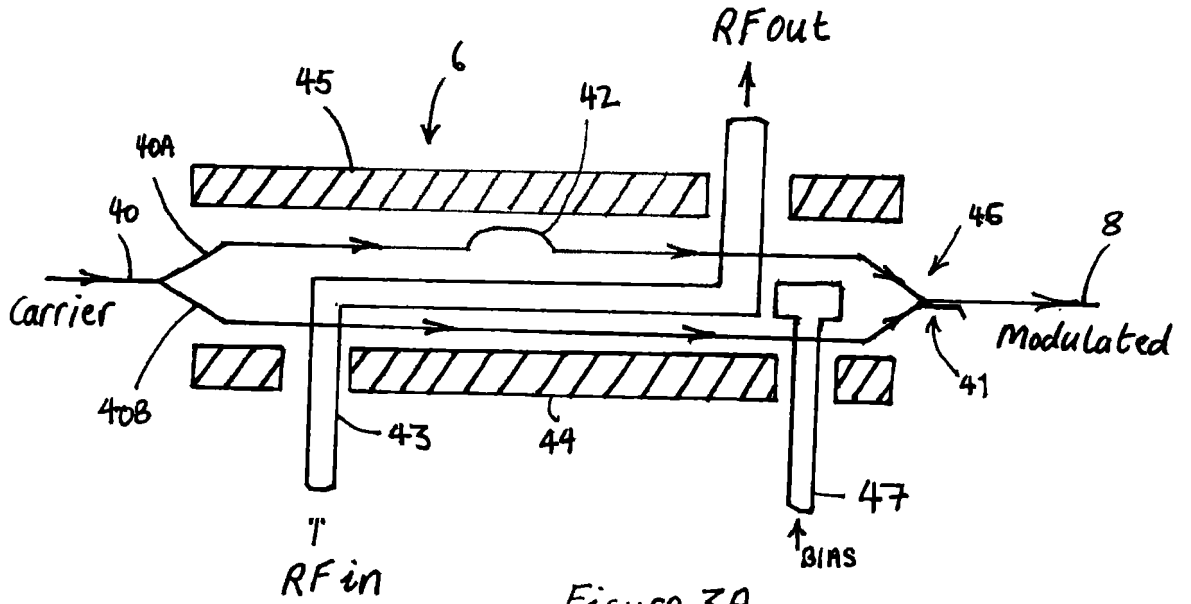

Figure 3A

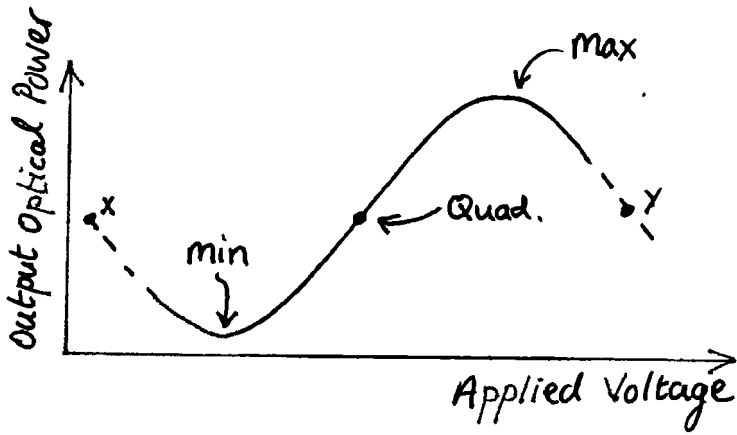

Figure 3B

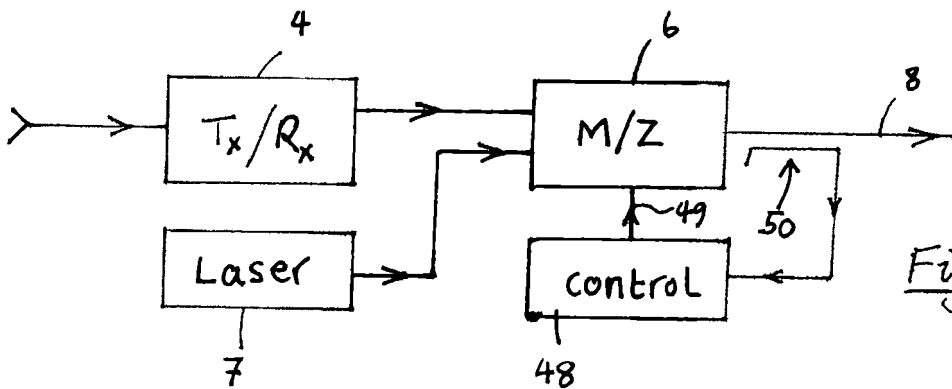

Figure 4

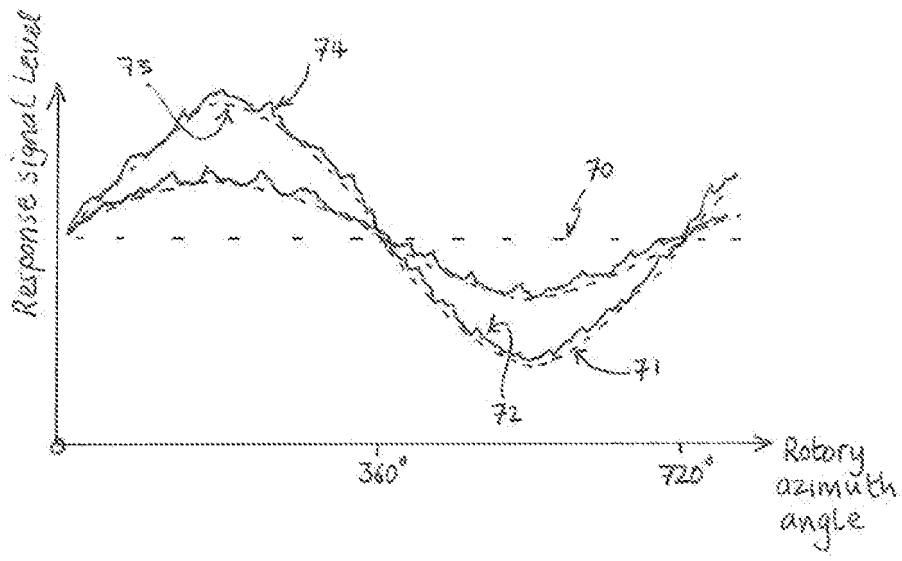

Figure 5

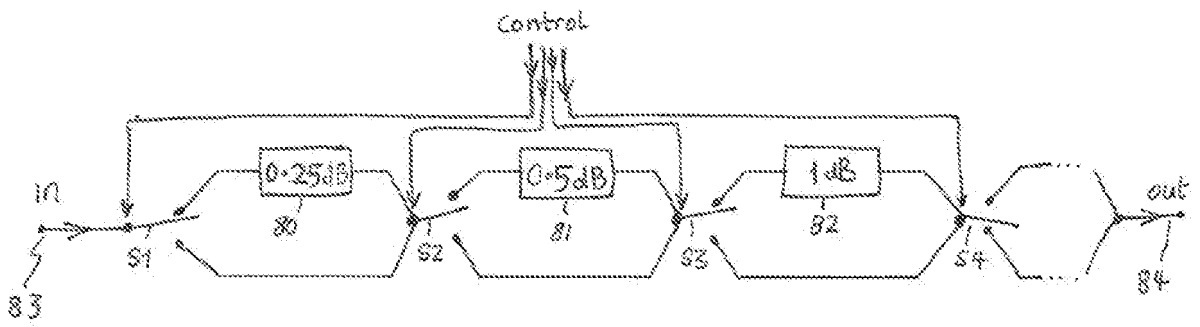

Figure 6

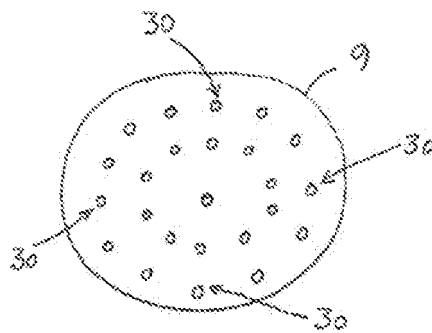

Figure 7



IMPROVEMENTS IN AND RELATING TO ANTENNAS

FIELD OF THE INVENTION

The present invention relates to antenna systems, and particularly, but not
5 exclusively, to rotating antenna systems with rotary joints.

BACKGROUND

The calibration of an antenna system typically requires the use of an
external RF (radio frequency) calibration signal source arranged to transmit a
10 predefined signal of known form, and to receive that signal via the antenna
system being calibrated.

By comparing the known form of the transmitted calibration signal to the
detected form of the received calibration signal, one may calibrate the receiving
antenna system according to the differences between the two. These
15 differences are assumed to be the result, largely, of system errors and
characteristics of the receiving antenna system and can be inverted to
determine a correction factor or process to be applied to subsequent received
signals. In this way, system errors and characteristics may be taken into
account and cancelled, at least to some extent, to improve the accuracy of the
20 antenna system.

This need for calibration is particularly important in rotating antenna
systems with rotary joints, such as most radar systems.

A typical rotary joint is an electro-mechanical device that provides the
required signal transfer interface between the stationary and rotating sections of
25 a rotating antenna system. It allows radio-frequency (RF) signals to be
transmitted back and/or forth between the antenna and other components of an
antenna apparatus.

RF rotary joints are used in many industries. These industries include
communication, satellites, aerospace and air traffic control, airborne systems,
30 shipboard systems, ground based radar.

A rotary joint is a passive rotating transmission line that has the ability to pass RF signals with minimal degradation. However, the more RF channels required to be transmitted, generally the longer must be the rotary joint. A rotary joint can be as simple as a one-channel transmission device which is typically small (a few cm in length), or as complicated as, say, a 73 channel transmission device which is much longer (about 5 metres long).

RF rotary joints can be made of copper, bronze, aluminium, stainless steel, specialty steels, silver, and specially clad or bi-metallic alloys. Important specifications for RF rotary joints include size, length and weight. Clearly, the metallic nature of RF rotary joints renders them relatively heavy.

Transferring a radio-frequency (RF) signal across the rotary joint of a rotating antenna, such as a radar antenna array, can require large and heavy RF rotary joints close to the antenna and typically high on an antenna mast, e.g. a ship's mast. This becomes a particular problem when considering antenna arrays having many RF channels, requiring a long and heavy RF rotary joint.

The invention addresses this.

SUMMARY OF THE INVENTION

The invention is to employ an internally generated RF calibration signal, rather than an externally generated and transmitted calibration signal, to calibrate an antenna system against system errors and characteristics. In particular, though not exclusively, the invention in some preferred embodiments is to modulate the power of an optical signal using an analogue electrical signal from an RF receiver or signal source of an antenna in order to transfer the analogue optical signal, conveying the information from within the RF electrical signal, across an optical rotary joint of the rotating antenna system. After transfer, the modulated analogue optical signal may then be converted into an electrical analogue signal and subsequently processed digitally. There is an increased difficulty in sufficiently accurately maintaining the optical signal amplitude/power of a given optical signal channel over the full rotational range of the rotary joint. It has been found that a generally sinusoidal gain/level

variation tends to occur in an optically transferred signal over this azimuth range. It has been found effective to employ the internally applied “mock external” calibration signal, which is not applied via the radiating antenna elements, to calibrate the antenna system against system errors and characteristics of the optical rotary joint.

For example, a transmitter unit may internally feed a predefined RF calibration signal directly (i.e. without radiating it from an external location) into a receiver of the antenna of the system. The calibration signal mimics what the receiver would “see” if a predetermined external RF signal had been received by the antenna elements of the system, and fed to the receiver in the usual, traditional way. The response of each receiver channel, such as each optical channel in the Dove prism, can then be characterised and calibrated against. This allows a controlled calibration to be applied at any time without the need for an external calibration RF source.

In preferred embodiments the invention may include a calibration of an analogue RF signal received via an optical rotary joint in which separate corrections are calculated for separate values of rotational position of the optical rotary joint, preferably a range of corrections are determined spanning the whole range of different rotational positions of the joint. The corrections may be for variations in signal level and/or signal phase, and/or signal noise level (e.g. signal-to-noise ratio) which may all vary according to the rotational position of the optical rotary joint.

A two-part correction may be applied in which corrections accounting for variations in signal noise levels at varying rotational positions of the optical rotary joint, are applied to the optical signals when in analogue form – e.g, via an analogue signal processor, whereas corrections accounting for variations in signal levels and/or phase at varying rotational positions of the optical rotary joint, are applied to the optical signals subsequently when in digital form – e.g, via digital signal processor.

Analogue signal transmission across the optical rotary joint removes the need for analogue-to-digital processors at the antenna array. It has been found possible to optically transfer analogue data within electrical analogue signals in

this way such that the amplitude of the transferred analogue signal is accurately transferred and recovered when converted back into an electrical analogue output signal, particularly when the rotary joint is calibrated as described herein.

This is a surprising result, since in the technical field of the invention, there
5 exists a perception that the optical transfer of data in RF communications systems should always be digital since digital data signals in general are often less susceptible to data loss or errors during transmission, and far more amenable to error correction. It is perceived that there would be generally insurmountable difficulty in sufficiently accurately controlling optical signal
10 amplitude/power levels necessary to achieve desired accuracy in data transfer by analogue signals, especially when transferring multiple signal channels.

The invention in preferred embodiments preferably employs a "Dove" prism, or an "Abbe-Konig" prism, both also known as a reversion prism within the optical rotary joint. When such a prism is rotated about its length axis, an
15 image viewed through the prism rotates at twice the prism rotation rate, but the output position remains unchanged, and an output ray is parallel with the input ray at all prism rotation angles.

Multiple channels may be transferred to the reversion prism on a corresponding multitude of input optical fibres, or waveguides, which rotate with
20 the antenna, and after having transferred across the reversion prism, each channel may then be output from the reversion prism to another corresponding multitude of optical fibres, or waveguides, that are non-rotating.

In a first aspect, the invention may provide a method for calibrating an antenna system including an antenna element(s) connected to a signal receiver
25 unit(s) at an RF signal input port thereof comprising, generating an RF calibration signal, applying the RF calibration signal to the RF signal input port of the signal receiver unit(s) without applying the calibration signal via the antenna element(s), measuring the response of the antenna system to the calibration signal, calculating a signal correction according to the measured
30 response, applying the signal correction to the response of the antenna system to signals subsequently received at said signal receiver unit(s) via the antenna element(s) of the antenna system.

The method may include generating the RF calibration signal using an RF signal transmitter and transmitting the RF calibration signal to the RF signal input port directly via a signal transmission line connecting the RF signal transmitter to the RF signal input port of the signal receiver.

- 5 A value of the signal correction may be calculated according to the inverse of a value of the measured response.

The method may be applied to an antenna system comprising a rotary antenna, and may comprise, outputting from the signal receiver unit(s) an RF analogue signal as a response thereof to the applied RF calibration signal, receiving the analogue RF signal at an optical modulator(s) and modulating an optical signal therewith to produce a modulated analogue optical signal(s), optically transmitting the modulated analogue optical signal(s) to an opto-electrical converter via an optical rotary joint including a reversion prism, converting the modulated analogue optical signal(s) into an analogue electrical signal(s) using the opto-electrical converter(s), and calculating a signal correction(s) according to the analogue electrical signal(s).

The method may include rotating the rotary antenna through 720 degrees of rotation angle/position (e.g. azimuth), applying the RF calibration signal continuously, or at suitably regular intervals, during the 720 degrees of rotation angle/position, and calculating a plurality of the signal correction(s) corresponding to a plurality of the rotation angles/positions spanning the 720 degrees. It will be appreciated that a 720 degree rotation of the rotary antenna results in a 360 degree rotation of the reversion prism within the rotary joint.

The method may include converting the analogue electrical signal(s) into digital electrical signals and calculating the signal correction(s) according to the digital electrical signal(s).

The method may include applying a signal correction to the analogue electrical signal(s) to reduce the effects of noise levels therein, and subsequently converting the analogue electrical signal(s) into digital electrical signal(s). The method may include converting these noise-corrected analogue electrical signal(s) into digital electrical signals and calculating the signal correction(s) according to those noise-corrected digital electrical signal(s).

In a second aspect, the invention may provide an antenna system including, an antenna element(s) connected to a signal receiver unit(s) at an RF signal input port thereof comprising, a calibration RF signal transmitter arranged to generate an RF calibration signal, and to apply the RF calibration signal to the
5 RF signal input port of the signal receiver unit(s) without applying the calibration signal via the antenna element(s), a calibration controller arranged to measure the response of the antenna system to the calibration signal, to calculate a signal correction according to the measured response, and to apply the signal correction to the response of the antenna system to signals subsequently
10 received at said signal receiver unit(s) via the antenna element(s) of the antenna system. The calibration controller may be a signal processor, including a digital signal processor, or an analogue signal processor or both.

The RF calibration signal transmitter is preferably connected to the RF signal input port directly via a signal transmission line connecting the RF signal
15 transmitter to the RF signal input port of the signal receiver.

The calibration controller may be arranged to calculate a value of the signal correction according to the inverse of a value of the measured response.

The antenna system preferably comprises an optical rotary antenna, and the signal receiver unit(s) are preferably arranged to output an RF analogue signal
20 as a response thereof to the applied RF calibration signal for transmission optically through the optical rotary joint in order to characterise/calibrate the joint. The antenna system may include an optical modulator(s) arranged to receive the analogue RF signal and to modulate an optical signal therewith to produce a modulated analogue optical signal(s), an opto-electrical converter
25 arranged to converting the modulated analogue optical signal(s) into an analogue electrical signal(s), an optical rotary joint including a reversion prism arranged to optically transmit the modulated analogue optical signal(s) from the optical modulator(s) to the opto-electrical converter. The calibration controller is preferably arranged to calculate a signal correction(s) according to the analogue
30 electrical signal(s). This may be by directly processing the analogue signals with an analogue signal processor and/or by digitally processing the signals after

they have been converted into digital signals (e.g. after an initial analogue processing).

The calibration controller is preferably arranged to apply the RF calibration signal continuously during a 720 degree rotation (e.g. azimuth angle) of the angular position of the rotary joint, and to calculate a plurality of signal correction(s) corresponding to a plurality of angular positions spanning the 720 degrees.

The antenna system may include an analogue-to-digital (A/D) converter arranged to convert the analogue electrical signal(s) into digital electrical signals, and the calibration controller may be arranged to calculate the signal correction(s) according to the digital electrical signal(s).

The antenna system may include an analogue signal processor arranged to receive the analogue electrical signals, and the calibration controller may be arranged to control the analogue signal processor to apply a noise reduction correction to the analogue electrical signal(s).

The invention in another aspect may provide a computer program or plurality of computer programs arranged such that when executed by a computer system it/they cause the computer system to operate to control an optical signal transmission apparatus in accordance with the method described above, or a machine-readable storage medium storing such a computer program or at least one of the plurality of computer programs.

In a third aspect, the invention may provide an optical signal transmission apparatus for a rotating antenna comprising, a plurality of optical modulators arranged for receiving a respective plurality of analogue RF signals and for modulating a respective plurality of optical signals therewith to produce a plurality of modulated analogue optical signals, a plurality of opto-electrical converters for converting a respective modulated analogue optical signal into an analogue electrical signal, wherein the plurality of optical modulators are rotationally coupled in optical communication with the plurality of opto-electrical converters via an optical rotary joint including a reversion prism. The reversion prism may be a Dove prism or an Abbe-Konig prism.

The optical modulators preferably include a laser, such as a continuous-wave laser, for generating an optical carrier signal and an optical modulator unit (e.g. a Mach-Zehnder (MZ) modulator) arranged to modulate the carrier signal according to the analogue RF signal.

- 5 The optical modulator unit preferably includes a biasable component being configurable to be biased by the application of a bias voltage such that the modulator operates at quadrature.

10 The optical signal transmission apparatus may include a bias control means arranged to vary the bias voltage applied to the biasable component until the value of the bias voltage is the value closest to a bias voltage (e.g. 0 (zero) Volts) at which the modulator operates at quadrature. This allows the apparatus to maintain operation of the optical modulator units with a more consistent modulation transfer characteristic thereby better maintaining a desired accuracy in modulated analogue optical signal levels over a wider
15 dynamic range.

20 The reversion prism is preferably rotationally coupled to the plurality of optical modulators and the plurality of opto-electrical converters so as to be rotatable relative to both at an angular rate of rotation that is substantially half the angular rate of rotation at which the plurality of optical modulators are concurrently rotatable relative to the plurality of opto-electrical converters. Thus, the optical modulators may be arranged on a rotary part of an antenna assembly and the opto-electrical converters may be arranged on a stationary part of the assembly together with electrical signal processing components and control components of the assembly. Gearing means may couple a housing
25 containing the optical modulators to a housing containing the reversion prism and may be arranged to transfer rotary motive force to the housing containing the reversion prism from the housing containing the optical modulators at substantially one half (1/2) the angular rate.

30 The optical signal transmission apparatus may comprise a first optical collimator unit arranged to receive and to collimate a said plurality of modulated analogue optical signals for input to the reversion prism, and a second optical

collimator unit arranged to receive and to collimate the plurality of modulated analogue optical signals output from the reversion prism, wherein the first and second collimator units share substantially parallel axes of collimation. Preferably, the first optical collimator unit is arranged to receive analogue optical signals from the second optical collimator unit – i.e. operating reciprocally, or as a two-way optical transfer set-up.

The optical signal transmission apparatus may comprise at least 20 optical modulators and 20 opto-electrical converters, or at least 30. Thus, many optical analogue signal channels may be provided for transferring optically via the optical rotary joint. The first and second optical collimator units may each comprise a corresponding number of optical fibres which terminate therein and are in optical communication with a respective one of the optical modulators and opto-electrical converters, respectively, of the apparatus. The optical axes of the optical fibres at the terminal ends thereof in each of the first and second collimator units is preferably parallel to the optical axis of the reversion prism between them. In this way, any one optical fibre terminal end in one of the first and second collimator units is maintained, by the reversion prism, in optical communication with the same one optical fibre terminal end in the other one of the first and second collimator units, irrespective of the state of relative rotation of the two collimator units.

In a fourth aspect, the invention may provide a method for optical signal transmission for a rotating antenna comprising, receiving a plurality of analogue RF signals at a respective plurality of optical modulators and modulating a respective plurality of optical signals therewith to produce a plurality of modulated analogue optical signals, optically transmitting the plurality of modulated analogue optical signals to a plurality of opto-electrical converters via an optical rotary joint including a reversion prism, converting each modulated analogue optical signal into a respective analogue electrical signal using the plurality of opto-electrical converters .

The optical modulators preferably include a laser for generating an optical carrier signal and an optical modulator unit (e.g. a Mach-Zehnder (MZ)

modulator), and the method preferably includes modulating the carrier signal using the optical modulator unit according to the analogue RF signal. The analogue RF signal may be applied to the optical modulator unit as a modulation signal.

- 5 The optical modulator unit preferably includes a biasable component, and the method preferably includes biasing the bias able component by the application of a bias voltage such that the modulator operates at quadrature.

10 The method may include varying the bias voltage applied to the biasable component until the value of the bias voltage is the value closest to a bias voltage (e.g. 0 (zero) Volts) at which the modulator operates at quadrature.

15 The method may include rotating, in use, the plurality of optical modulators relative to the plurality of opto-electrical converters at an angular rate of rotation, and concurrently rotating the reversion prism relative to the plurality of optical modulators and the plurality of opto-electrical converters at an angular rate of rotation that is substantially half the angular rate of rotation.

20 The method may comprise collimating the plurality of modulated analogue optical signals according to a first axis of collimation, inputting the collimated plurality of modulated analogue optical signals to the reversion prism, and receiving and collimating the plurality of modulated analogue optical signals output from the reversion prism according to second axis of collimation substantially parallel to the first axis of collimation. The method may include collimation in this way for optical transfer in any direction through the reversion prism.

25 The method may include receiving, optically modulating, optically transmitting and subsequently demodulating at least 20, or at least 30, analogue RF signals concurrently.

30 In a further aspect, the invention provides a computer program or plurality of computer programs arranged such that when executed by a computer system it/they cause the computer system to operate to control an optical signal transmission apparatus in accordance with the method of any of the above aspects.

In a yet further aspect, the invention provides a machine-readable storage medium storing a computer program or at least one of the plurality of computer programs according to the above aspect.

The apparatus in the third aspect may comprise the apparatus according to
5 the second aspect of the invention. The method in the fourth aspect may comprise the method in the first aspect of the invention.

BRIEF DESCRIPTION OF THE DRAWINGS

Figure 1 schematically illustrates a radar antenna system comprising a
10 radar antenna array rotationally coupled to a radar signal processing system via an optical rotary joint;

Figure 2 shows a cross-sectional schematic of an optical rotary joint;

Figures 3A and 3B show a Mach-Zehnder optical modulator, and the transfer function of an on optical modulator;

15 Figure 4 schematically shows the optical modulator of Figure 3A in combination with input and control elements shown in Figure 1;

Figure 5 shows graphically the variation in response of two channels of the optical rotary joint as a function of rotational position of the joint across an angular (azimuth) range spanning 720 degrees corresponding to a complete
20 360 degree rotational range of the reversion prism within the rotary joint;

Figure 6 schematically shows a stepped attenuator employed in an analogue signal processor of an embodiment of the invention;

Figure 7 shows an end of one of the first and second collimator units of Figure 1 or 2, showing an array of 24 separate optical transmission channels
25 within the optical rotary joint.

DETAILED DESCRIPTION

In the drawings, like items are assigned like reference symbols for consistency.

Figure 1 shows a radar system 1 comprising an antenna array 2 having four separate antenna radiating elements 3 (or sub-arrays of multiple radiating elements) each served by a respective one of four separate RF transmitter/receiver units 4. It is to be noted that while only four signal channels are shown here, this is purely for illustrative purposes, and many more such channels may be present in other embodiments. Each transmitter/receiver unit contains a receiver apparatus for receiving RF signals, such as radar return (echo) signals, from a respective antenna radiating element and for generating amplified RF electrical signals typically via a superheterodyne or the like such as would be readily apparent to the skilled person. Also, each transmitter/receiver unit contains a transmitter apparatus for generating RF radar output signals for radiation by a respective antenna radiating element. Each of the transmitter and receiver apparatus is connected to a common radiating element via a duplexer (not shown) which protects the receiver apparatus from signals generated by the transmitter apparatus, and directs received radar signals to the receiver apparatus. These components of apparatus may be such as would be readily apparent to the skilled person.

Each of the four transmitter/receiver units has a receiver analogue output RF transmission line 5 connected to an RF input modulation signal port of a respective one of four Mach-Zehnder (MZ) optical modulators 6 which also each have an optical carrier signal input port connected to receive an optical carrier signal from a laser unit 7 arranged to generate four separate optical carrier signals for each respective one of the four (MZ) optical modulators. The laser unit may comprise one or more laser light sources (e.g. solid-state lasers or otherwise) controlled to generate a substantially constant intensity optical output for use as a carrier signal. One such laser light source may be arranged to generate an optical carrier signal for two or more MZ modulators in common, and may be optically coupled thereto via an optical power divider such that two MZ modulators are served by sharing/splitting carrier light from one laser source.

Each MZ optical modulator is arranged to modulate the optical carrier signal received by it with analogue RF voltage signal received by the MZ

modulator at its RF input modulation signal port, and to output the modulated analogue optical signal on a respective optical fibre 8 to a respective one of four collimator input ports of a first collimator unit 9 of an optical rotary joint 10, via a respective optical fibre. A bias is applied to each MZ modulator to control the MZ modulator so as to operate at or close to quadrature, as is explained in more detail below, with reference to figures 3A, 3B and 4.

The optical rotary joint comprises a prism unit 11 containing a Dove prism (another type of reversion prism such as an Abbe-Konig prism may be used) which optically couples the modulated optical signals of each one of the four collimator input ports to a respective one of four collimator output ports of a second collimator unit 12 of the optical rotary joint. Each collimator unit is arranged to collimate a modulated optical signal received thereby. The axis of collimation of the first collimator unit is parallel to that of the second collimator unit. However, the first collimator unit is fixed to the rotating antenna head of the radar system which is arranged to rotate about a rotation axis parallel to the collimation axis, at a given angular rate of rotation (ω) and is, therefore, rotary, whereas the second collimator unit is fixed to the stationary part of the radar system and does not rotate. The prism unit, located intermediate the rotary first collimator unit and the stationary second collimator unit, is arranged to rotate with the first collimator unit about the same axis of rotation but at half the angular rate of rotation ($\omega/2$). Thus, the first collimator unit is arranged to rotate relative to both the prism unit and the second collimator unit.

In this way, optical modulated (analogue) signals are transmitted from a rotating antenna element array to a stationary signal processing system via an optical rotary joint. Analogue to digital (A/D) conversion of signals is not required prior to transmission through the optical rotary joint and may be performed after such transmission. In this way, a compact optical rotary joint is provided which obviated the need for (A/D) converters in the rotating head of the antenna system.

The second collimator unit possesses four separate collimator output ports which each direct a collimated, modulated RF (analogue) optical signal via a

respective one of four optical fibres 13, to a respective one of four separate opto-electrical converters 14 each arranged to convert a received analogue, modulated optical signal into a corresponding analogue, modulated RF electrical signal. Each opto-electrical converter may comprise a photodiode which is reverse-biased. Modulated light incident upon the photodiode is converted into a current proportional to the intensity of the incident light. The output of the photodiode is connected electrically in series to a resistor (not shown) which generates a voltage in proportion to the photodiode current. In alternative embodiments, the resistor may be replaced with a trans-impedance amplifier which may provide greater sensitivity in converting optical signals to voltage values.

The electrical, analogue modulated RF signals generated by the opto-electrical converters are each input to an analogue RF signal processor 15 of the type typically used in a radar apparatus for processing, such as amplification, filtering or the like, and subsequently output to an analogue-to-digital (A/D) signal converter 20 for subsequent output to a digital signal processor unit 21 for analysis, processing and general use, as desired by a user.

A transmitter control unit 16 is also provided which is arranged to generate digital control signals for controlling the operation of the transmitter apparatus within the transmitter/receiver units, and also signals for controlling the operation of a calibration signal transmitter unit 61 separate from the transmitter/receiver units. The transmitter control unit is arranged to output digital electrical transmitter control signals 17 to an electro-optical signal converter unit 18 arranged to convert the digital electrical signals into digital optical signals in a manner such as would be readily available to the skilled person. For example, the electro-optical signal converter may be a diode laser arranged to be driven by a drive signal containing the digital electrical transmitter/calibration control signals such that a digital optical signal is generated conveying the digital electrical signals in question. This digital optical signal is input to the second (stationary) optical collimator unit 12 and is subsequently transmitted via the Dove prism 11 to the first optical collimator unit

9 whereupon it is output by the first collimator unit to an opto-electrical converter
18 (being any suitable variety, such as would be readily available and apparent
to the skilled person) arranged to convert the digital optical signals into digital
electrical signals and output the result. This may comprise a transmitter control
5 signal 19 for input to each one of the four transmitter/receiver units 4 to control
the operation (e.g. transmitter power, timing) of the transmitter units via the
transmitter control signals, or to control the operation of the receiver units.
Alternatively, it may comprise a calibration transmitter control signal 60 to
control operation of the calibration transmitter unit 61 as described below with
10 reference to Figures 5, 6 and 7.

Optical transfer of the control signals via the optical rotary joint may be as
described above in relation to optical transmission of modulated receiver signals
8, but in reverse direction via a fifth optical transmission path (not shown). The
first and second collimator units may each comprise additional optical
15 transmission paths like those illustrated, for additional optical channels.

Figure 2 shows a schematic cross-sectional view of the optical rotary joint
described above with reference to Figure 1.

The optical rotary joint 10 comprises a prism unit including a Dove prism
22 mounted within a prism mounting unit 23 fixed within the bore 25 of a prism
20 housing part 24. The bore of the prism housing part is a through-bore which
extends from one end of the housing part to the other axially along the central
axis 26 of the prism housing. The Dove prism is a trapezoidal reversion prism
defining a longitudinal, optical axis 26 therethrough and having opposite end
faces 27 that are disposed at opposite but equal angles (e.g. 45 degrees)
25 relative to the optical axis. As a result, optical signals 28 emitted parallel to the
optical axis are received at one angled end (input/output) surface of the Dove
prism and are refracted towards the longer trapezoidal base surface 29 of the
prism where they are totally internally reflected to the second, opposite angled
end (input/output) surface of the prism whereupon they are refracted as they
30 exit the prism along a direction parallel to the optical axis. The longer base
surface of the Dove prism is planar and parallel to the optical axis of the prism.

Each one of the two angled end surfaces of the Dove prism is fully exposed by, and optically accessible via a respective and of the through-bore of the prism housing.

One end of the prism housing is mechanically coupled to a first collimator unit 9 containing an array of four optical fibre terminal ends 30 held in parallel side-by-side array within four parallel respective optical fibre housing bores 31 each housing an end of a respective one of the four optical fibres connected to the four MZ optical modulators. The axis of each optical fibre housing bore is parallel to the optical axis of the Dove prism, and each fibre housing bore terminates with an opening which places a terminal end 32 of the optical fibre therein in view of one angled end (input/output) surface of the Dove prism, via a converging collimation lens 33 housed within the respective fibre housing bore between the terminal end of the housed fibre and the terminal and of the fibre housing bore. Each collimation lens is arranged to collimate an optical signal output from the optical fibre within the fibre housing bore into a collimated optical beam parallel to the optical axis of the Dove prism, and also to receive a collimated optical signal from the Dove prism and direct it into the optical fibre within the fibre housing bore, when transmitting optical signals in the opposite direction. In each of the first and second collimator units, additional optical fibre housing bores house additional optical fibres and collimation lenses but are not shown in the cross-sectional view of Figure 2. For example, a fifth optical fibre housing bore houses a fifth optical fibre and a fifth collimation lens, in each of the first and second collimator units, which are in optical communication via the Dove prism and serve as an optical transfer channel for transmitter control signals (17) sent to the transmitter units (4). Further such pairs or optically communicating fibres may be provided by the collimator units in any pattern within both collimator units – shared by each.

The other end of the prism housing is mechanically coupled to a second collimator unit 12 containing an array of four optical fibre terminal ends 34 substantially identical to those of the first collimator unit. The four optical fibres are coupled to the second collimator unit with their terminal ends held in parallel side-by-side array within four parallel respective optical fibre housing bores 36.

The axis of each fibre housing bore is parallel to the optical axis of the Dove prism, and each fibre housing bore terminates with an opening which places a terminal end of the optical fibre end therein in view of the other one of the angled end (input/output) surfaces of the Dove prism, via a converging collimation lens 37 housed within the respective fibre housing bore between the terminal end of the housed fibre and the terminal end of the fibre housing bore. Each collimation lens is arranged to receive a collimated optical signal transmitted from the first collimator unit via the Dove prism and direct it into the optical fibre within a fibre housing bore of the second collimator unit. Conversely, each collimation lens may collimate an optical signal output from the optical fibre within the fibre housing bore of the second collimator unit, into a collimated optical beam parallel to the optical axis of the Dove prism for transmission to an optical fibre within the first collimation unit, when transmitting optical signals in the opposite direction.

The first collimator unit is rotationally coupled to the prism unit so as to be rotatable about the optical axis 26 of the Dove prism at a selected angular rate of rotation (ω) corresponding to the rate of rotation of the antenna array to which the first collimator unit is fixedly coupled. The prism unit is coupled to the first collimator unit so as to rotate at half the angular rate of rotation ($\omega/2$) of the first collimator unit. This coupling is via a scale-down element or other speed-change gear mechanism (not shown) for transmitting the rotation of the first collimator unit to the prism unit at an angular velocity half the angular velocity of the first collimator unit. In this way, the mechanical power with which the rotating antenna array of the radar apparatus is rotated is transferred to the prism unit at the appropriate, scaled-down rate via the first collimator unit so as to drive rotation of the Dove prism at the appropriate rate. The prism unit is rotationally coupled to the non-rotating second collimator unit so as to be rotatable about the optical axis of the Dove prism 26 at the selected angular rate of rotation ($\omega/2$).

Each optical fibre 30 within the first collimator unit is optically coupled, and paired, to the same one optical fibre 38 in the second collimator unit, via the Dove prism. When the Dove prism is rotated about its optical axis, the position

of an optical fibre within the first collimator unit rotates relative to the position of the corresponding (paired) optical fibre of the second collimator unit, at twice the relative prism rotation rate. However, optical coupling between the two paired optical fibres, provided by the Dove prism, remains unchanged at all prism rotation angles. This is illustrated with two optical rays in Figure 2 at one angular position.

In this way, optical signals may be transmitted across the optical rotary joint.

The transmitted optical signals are analogue optical signals modulated with an RF signal generated by the antenna receiver units illustrated in Figure 3A. As discussed above, a Mach-Zehnder (MZ) modulator provides the mechanism whereby an input optical carrier signal may be modulated with the RF radar signal. In this embodiment, the optical modulator is an interferometer, created by forming an optical waveguide in a suitable substrate such as Lithium Niobate (LiNbO₃) or Gallium Arsenide (GaAs) or Indium Phosphide (InP).

An optical waveguide 40 of the MZ modulator is split into two branches, 40A and 40B, before being recombined at an optical coupler 41. An optical carrier signal in the form of a beam of light from a laser source 7 enters one side of the modulator as indicated by an arrow at the left-hand side of Figure 3A, and exits the modulator at the opposite side, i.e. at the right-hand side of Figure 3A, having passed through both branches, 40A and 40B, of the waveguide.

One of the waveguide branches 40A includes an asymmetry 42 that functions to introduce a phase difference between light travelling down respective branches of the waveguide. The phase difference is chosen to be approximately 90 degrees at the wavelength of operation, which is typically in the region of 1300 or 1550 nanometres. This induces a quadrature bias where the optical output power is nominally 50% of its maximum value.

Lithium Niobate (in common with other similar materials such as GaAs or InP) is a glass-like material with a crystal structure that exhibits an electro-optic effect whereby the refractive index of the crystal structure changes as a voltage

is applied thereto. In particular, the direction of the electric field induced by the applied voltage causes an increase or decrease in refractive index. An increased refractive index acts so as to slow light travelling through the crystal, and a decreased refractive index acts so as to increase the speed of light travelling through the crystal.

As shown in Figure 3A, a modulating electrode 43 is provided between the branches of the waveguide. When the modulating electrode is energised by an applied signal (e.g. a radio frequency signal), positive and negative electric fields are established between the modulating electrode and, respectively, a first 44 and a second 45 ground plane. The modulating electrode is designed as a transmission line so that the modulating signal travels with the optical carrier signal through the MZ modulator, thereby enabling high modulating frequencies to be achieved.

The positive and negative electric fields cause the refractive index of the two branches of the waveguide to change. A positive field causes an increase in refractive index for one branch, and a negative field causes a decrease in refractive index for the other branch, and the resulting different propagation speeds of the optical carrier signal through each branch cause a change in phase in the signals output to the optical combiner 46. This phase change causes the output power level of light from the optical combiner to change. In effect, as the electric fields experienced by each branch varies with the RF signal applied to the modulating electrode, so the phase difference between light passing through the two branches changes and the output power level of the optical signal output from the combiner varies accordingly. The net effect of this is that the input optical carrier signal is modulated with the RF signal applied to the modulating electrode.

Figure 3B is a schematic illustration (not to scale) showing the MZ modulator transfer function. This transfer characteristic of the MZ modulator is approximately sinusoidal. The most linear modulation tends to be achieved in and around the quadrature point (also known simply as "quadrature"). The quadrature point is the point where there is a 90 degree phase relationship

between light travelling through respective branches of the waveguide of the MZ modulator. The transfer function is a repeating function, and as such there are many quadrature points at different bias voltages but all with the same power output. Indicated in Figure 3B by the reference sign "Quad" is a first quadrature point. At this first quadrature point "Quad" the output power is increasing with bias voltage, and hence this quadrature point "Quad" is referred to as a positive slope quadrature bias point. Further quadrature points (e.g. shown as "x" and "y" in Figure 3B) occur either side of "Quad" where the output power is decreasing with bias voltage. These quadrature points are each referred to as negative slope quadrature bias points.

In practice, the preferred 90 degree phase shift is rarely achieved. To compensate for this, the MZ modulator according to preferred embodiments of the invention includes a biasable component 47, as shown in Figure 3A. A DC bias voltage is applied to the biasable component to return the MZ modulator to or near to one of the aforementioned quadrature points. In the arrangement depicted in Figure 3A, the biasable component comprises a discrete bias electrode (this is merely illustrative as a number of alternative arrangements are known to persons skilled in the art). For example, a bias voltage may be applied directly to the modulating electrode by means of a so-called bias-Tee. In such an arrangement, the DC bias may be coupled to the electrode via an inductor, and the applied signal (RF signal) would be coupled to the electrode via a capacitor.

The bias point, i.e. the voltage that needs to be applied to the biasable component to return the MZ modulator to or near the quadrature point, has been found to have a tendency to shift over time. For example, so-called trapped charges (e.g. that exist in the regions between electrodes, e.g. in a silicon dioxide buffer layer on the surface of the device) and temperature variations can each cause the bias point to shift at a rate of anything from a few millivolts per hour to several volts per hour. As such it is preferable to provide a dynamic bias control to enable modulator linearity to be maintained over an extended period of time.

In the analogue domain, this has been found to be important to enable accurate analogue optical transmission of RF signals.

A bias control unit 48 is arranged with the rotating antenna elements to apply a method of controlling a bias voltage supplied to each optical modulator, separately. Each MZ modulator comprises a biasable component 47 that is configurable to be biased by application of the bias voltage 49 such that the modulator operates at quadrature. The bias controller is arranged to provide a target for the output optical power of the MZ modulator which is an output power corresponding to the modulator operating at quadrature. The bias control unit applies to the biasable component a bias voltage having an initial value of 0V, and thereafter, it varies the bias voltage until the value of the bias voltage is the value that is closest to the initial value and that biases the biasable component so that the output optical power of the modulator is within a pre-defined range of the target output power.

The bias control unit monitors the output optical power of the MZ modulator and, if the output power of the modulator is determined to be outside the pre-defined range of the target output power, it further varies the value of the bias voltage so as to bring the output optical power of the modulator back to being within the pre-defined range of the target output power.

This step of further varying the value of the bias voltage may include comparing the output optical power of the modulator to the target output optical power to determine whether the output optical power of the MZ modulator is either higher or lower than the pre-defined range of the target output power. The bias control unit may determine a direction of a slope of the output optical power of the modulator relative to (as a function of) the applied bias voltage, and depending on the determined slope direction and whether the output power of the modulator is either higher or lower than the pre-defined range of the target output power, either increase or decrease the bias voltage by a predetermined amount (e.g. in steps of between 75mV and 150mV, e.g. 125mV).

The size of the predetermined amount by which the bias voltage is either increased or decreased may be selected or dependent upon how long the modulator has been operating at quadrature.

The step of varying the bias voltage may comprise comparing the output
5 power of the modulator to the target output power to detect when the output power of the modulator is within the pre-defined range of the target output power (e.g. within 5%, or preferably 2%, or more preferably 1%), or if the output power of the modulator is substantially equal to the target output power.

The step of varying the bias voltage may include starting at the initial
10 value, and then sweeping the bias voltage in a zigzag (temporal) pattern with gradually increasing amplitude. That is to say, e.g. by applying successive bias voltages of opposite sign and optionally of increasing magnitude. This may be an asymmetric pattern whereby the positive bias values of bias voltage within the pattern have magnitudes which are not repeated in the magnitude of
15 negative values. The varying of the bias voltage is preferably performed such that the bias voltage is confined to being within a pre-defined bias voltage range.

Figure 4 is a schematic illustration (not to scale) of an example of a bias controller as implemented on each RF signal transmission line 8 from the four
20 receiver units of the antenna of Figure 1.

The bias controller 48 is coupled to the MZ modulator 6 which is driven by a continuous wave laser 7 operable to provide an optical carrier signal with which an RF signal from the transmitter/receiver unit is to be modulated. In this example, the modulator includes a separate bias electrode 47 as shown in
25 Figure 3A, however other arrangements are possible.

The bias controller comprises a photodiode (not shown) that is coupled to the modulator output by means of an optical tap coupler 50. The optical tap coupler is operable to monitor the optical signal output of the MZ modulator and pass approximately 1 to 5% of that output to the photodiode. The photodiode is
30 reverse-biased. Light incident on the photodiode is converted to current, proportional to the incident light, which is passed through a resistor (not shown).

The resistor converts the current passed to the resistor to a voltage. The voltage dropped across the resistor is compared to a target voltage, which is a voltage that is indicative of a target optical power for the modulator for quadrature. This is done to determine whether the reference voltage (i.e. the voltage supplied by the resistor) is too high, too low, or acceptable relative to the target voltage. The terminology “acceptable” may, for example, be used to refer to reference voltages within 1% of the target voltage. The terminology “too high” may, for example, be used to refer to reference voltages that are greater than or equal to the target voltage plus 1%. The terminology “too low” may, for example, be used to refer to reference voltages that are less than or equal to the target voltage minus 1%. The bias control unit varies, as described above, (or maintains) the bias voltage applied to the MZ modulator accordingly.

The antenna system may comprise many more RF signal transmission lines/channels than the four shown in Figures 1 and 2, and may comprise at least 20 to 30 optical modulators and 20 to 30 opto-electrical converters, with the optical rotary joint comprising first and second collimator units having a corresponding 20 to 30 collimation bores optically coupled via the Dove prism.

Figure 5 shows schematically the variation in analogue signal level, 72 and 74, of two signal channels transferred across the optical rotary joint 10, Figures 1 and 2, and received by the analogue signal processor 15 from a respective one of two of the opto-electrical converters 14. Each signal level is plotted as a function of the angular position of the first collimator unit 9 relative to the second collimator unit 12 for a multitude of separate, successive angular positions spanning the range from 0 (zero) degrees to 720 degrees (i.e. two full rotations). The Dove prism rotates fully once (360 degrees) relative to both the first and second collimator units during this rotation range rotation. It has been found that, although collimation and optical communication between paired optical fibre ends, 32 and 34, within the first and second collimator units is maintained, there exists a variation in the optical transfer characteristic of the Dove prism when transferring a predetermined calibration optical signal between two paired optical fibres. This transfer characteristic varies both as a matter of the position of rotation (e.g. rotary azimuth angle) of the Dove prism,

and thus if the rotary joint, and also as a matter of the lateral position of the paired optical fibres relative to the optical axis 26 of the Dove prism, which is coincident with the rotational axis thereof.

A quasi-sinusoidal variation in signal level is found to occur in response to a predetermined calibration signal, when the calibration signal is applied repeatedly over each one of a multitude of rotation positions and plotted as shown in Figure 5. The period of the quasi-sinusoidal variation matches the rotation period of the Dove prism, and repeats for every full rotation of the Dove prism. The amplitude of the variation tends to be larger for paired optical fibres with a larger lateral distance from the optical axis 26 of the Dove prism. For example, Figure 7 schematically shows an end of one of the first collimator unit 9 of Figure 1 or 2, showing an array of 24 separate optical fibre ends within the optical rotary joint. The response signal level resulting from a predetermined calibration signal has a larger amplitude (curve 74 of Figure 5) in respect of outermost optical fibres, but is typically of smaller amplitude (curve 72) for optical fibres closer to the optical axis of the Dove prism.

The response signal levels also tend to display a noise level, in addition to the underlying systematic quasi-sinusoidal variation, 73 or 71, which varies according to the angular position of the Dove prism. Each angular position displays a noise level (e.g. signal to noise ratio) which is specific to that angular position. Although the noise itself varies randomly, of course, the general noise level does not vary randomly and can be accounted for or corrected for according to the invention in preferred embodiments. Indeed, both the systematic quasi-sinusoidal variation and the additive noise level may be corrected for with a calculated signal correction, described below, with the aim of producing a corrected response signal level 70 having far less or substantially no systematic variation or variation in noise levels across the range of angular positions of the Dove prism.

Referring to Figure 1, a predetermined calibration signal is generated by generating a calibration control signal, 17 and 60, at the transmitter control unit 16 and transmitting the control signal to the calibration RF signal transmitter unit 61 located with the transmit/receive units 4 of the antenna system, via the

optical rotary joint. This is achieved using the electrical/optical converters, 18, discussed above. The calibration RF signal transmitter unit is responsive to the calibration control signal to generate an RF calibration signal and input it directly to RF input port of the RF receiver unit in each of the transmit/receive units 4 via an RF signal transmission line, bypassing the radiating antenna elements 3 altogether. The RF receiver units are responsive to this RF calibration signal to generate an RF output signal just as if they had received a radio signal via the antenna radiating elements 3. In this sense, the RF calibration signal is a “mock” signal which obviates the need to generate a calibration signal externally.

The optical modulators 6 of each signal channel respond to the output of the respective receiver units by generating and outputting nominally identical modulated optical signals 8 for input to the optical rotary joint 10 via the first collimator unit 9. The modulated optical signals are transferred through the optical rotary joint by the Dove prism within it, and input to the analogue signal processor 15 as modulated electrical signals via the respective opto-electrical converters 14.

The transmitter control unit is arranged to repeat this process for each one of a multitude of successive angular positions of the optical rotary joint spanning a full 720 degrees. The result of each repeat of this process is shown schematically for two signal channels.

The calibration control signal is preferably one which will cause the receiver units of the transmit/receive units 4 to output a simple, easily reproducible RF signal shape, such as a square pulse or other simple pulse shape.

The analogue signal processor is arranged to apply an appropriate attenuation to each value of the measured response signal (72, 74) at a given rotary position, which is determined according a detected noise level in that signal.

The noise levels are determined, typically, by the sensitivity of analogue-to-digital converters (ADC) employed for converting analogue signals to digital signals prior to input to the digital signal processor. The gains and noise

performance (noise figure) of intervening devices between the antennas and the analogue signal processor (principally, but not exclusively, amplifiers) are typically substantially known and may be selected/adjusted to transform the antenna noise level to the appropriate level of a particular ADC device. The level is preferably chosen as a few least significant bit quanta above the lowest signal that the ADC will respond to. The gains, etc of the intervening devices are often subject to variation (or tolerance) due to manufacturing variances/tolerances. The optical rotary joint has been found typically to add in further variation as a function of its rotation angle. A calibration is performed in the analogue domain to remove the initial, static, variation due to the receiver components (amplifiers etc) and a dynamic calibration is performed (e.g. subsequently) to account for the rotational variation. Both calibrations can be combined in a single operation.

The appropriate attenuation is applied using a stepped attenuator in respect of the given channel being processed. Figure 6 schematically illustrates the principle of the stepped attenuators. An input response signal is received at an input port 83 of the attenuator whereupon it is directed to a first switching unit S1 controllable to connect the input port to one of two signal transmission branch lines. A first branch line contains a first signal attenuator unit 80 and a second branch line contains no attenuators. The first signal attenuator unit is arranged to apply 0.25dB of signal attenuation. Each branch line re-connects to the other at a second switching unit S2. The second switching unit is controllable to connect to one of two subsequent signal transmission branch lines one of which contains a second signal attenuator unit 81 and the other of which contains no attenuators. The second signal attenuator unit is arranged to apply 0.5dB of signal attenuation. Each branch line re-connects to the other at a third switching unit S3. The third switching unit is controllable to connect to one of two subsequent signal transmission branch lines one of which contains a third signal attenuator unit 82 and the other of which contains no attenuators. The third signal attenuator unit is arranged to apply 1dB of signal attenuation. Each branch line re-connects to the other at a fourth switching unit S4. This

pattern may be repeated to accommodate attenuator units for 1dB, 4dB etc signal attenuation.

The analogue signal processor 15 is arranged to direct signals it receives upon in channels from the optical rotary joint into a respective stepped attenuator such as is shown in Figure 6 and therewith to apply a desired attenuation to the analogue signal by controlling the switch state of each of the first to fourth (or more) switch units if the stepped attenuator to achieve the desired attenuation level. By switching a given switch unit to connect to a transmission branch line containing an attenuator, an attenuation level may be increased, whereas it will not be increased if the switch is switched otherwise. The attenuators may be such as would be readily apparent and available to the skilled person (e.g. serial, ladder or shunt-type attenuators comprising arrays of resistors, or otherwise).

An attenuation associated with a given channel and a given rotary position/angle may be stored or tabulated by the apparatus so as to be applied at each repeat rotary positioning of the rotary joint in subsequent use, while noise levels for that channel and at that rotary position remain sufficiently steady, at least otherwise until such time as a re-calibration is deemed desirable.

It has been found to be beneficial to control noise levels in the analogue signal domain in this way so as to enable more accurate and efficient subsequent digital signal processing as described below.

The analogue signal processor is arranged to output to the digital signal processor 21, via the A/D converter 20, the noise-reduced signals produced thereby for each channel received from the rotary joint. The digital signal processor is arranged to tabulate the variation in the received response signal levels for each channel over the 720 degree range of rotary positions and to calculate an inverse value thereof for applying to subsequent received signals thereby to reverse the effect of the systematic quasi-sinusoidal variation (71, 73) cause by the optical rotary joint.

The embodiments described above are presented for illustrative purposes and it is to be understood that variations, modifications and

equivalents thereto such as would be readily apparent to the skilled person are encompassed within the scope of the invention.

CLAIMS:

1. A method for calibrating an antenna system including an antenna element(s) connected to a signal receiver unit(s) at an RF signal input port thereof comprising:
5

generating an RF calibration signal;

applying the RF calibration signal to the RF signal input port of the signal receiver unit(s) without applying the calibration signal via the antenna element(s);
10

measuring the response of the antenna system to the calibration signal;

15 calculating a signal correction according to the measured response;

applying the signal correction to the response of the antenna system to signals subsequently received at said signal receiver unit(s) via the antenna element(s) of the antenna system.
20
2. A method according to any preceding claim including generating said RF calibration signal using an RF signal transmitter and transmitting said RF calibration signal to said RF signal input port directly via a signal transmission line connecting the RF signal transmitter to the RF signal input port of the signal receiver.
25

3. A method according to any preceding claim in which a value of the signal correction is calculated according to the inverse of a value of the measured response.

- 5 4. A method according to any preceding claim wherein the antenna system comprises a rotary antenna, the method comprising:

outputting from the signal receiver unit(s) an RF analogue signal as a response thereof to the applied RF calibration signal;

10 receiving the analogue RF signal at an optical modulator(s) and modulating an optical signal therewith to produce a modulated analogue optical signal(s);

15 optically transmitting the modulated analogue optical signal(s) to an opto-electrical converter via an optical rotary joint including a reversion prism;

converting said modulated analogue optical signal(s) into an analogue electrical signal(s) using said opto-electrical converter(s); and

20 calculating a signal correction(s) according to the analogue electrical signal(s).

- 25 5. A method according to claim 4 including rotating said rotary antenna through 720 degrees of azimuth angle, applying said RF calibration signal continuously during said 720 degrees of azimuth angle rotation, and calculating a plurality of said signal correction(s) corresponding to a plurality of said azimuth angles spanning said 720 degrees.

- 30 6. A method according to claim 4 or 5 including converting said analogue electrical signal(s) into digital electrical signals and calculating said signal correction(s) according to the digital electrical signal(s).

7. A method according to claim 6 including applying a noise reduction correction to said analogue electrical signal(s) and subsequently converting the analogue electrical signal(s) into said digital electrical signal(s).

8. An antenna system including:

an antenna element(s) connected to a signal receiver unit(s) at an RF signal input port thereof comprising:

a calibration RF signal transmitter arranged to generate an RF calibration signal, and to apply the RF calibration signal to the RF signal input port of the signal receiver unit(s) without applying the calibration signal via the antenna element(s);

a calibration controller arranged to measure the response of the antenna system to the calibration signal, to calculate a signal correction according to the measured response, and to apply the signal correction to the response of the antenna system to signals subsequently received at said signal receiver unit(s) via the antenna element(s) of the antenna system.

9. An antenna system according to claim 8 in which said RF calibration signal transmitter is connected to the RF signal input port directly via a signal transmission line connecting the RF signal transmitter to the RF signal input port of the signal receiver.

10. An antenna system according to any of preceding claims 8 to 9 in which the calibration controller is arranged to calculate a value of the signal correction according to the inverse of a value of the measured response.

11. An antenna system according to any of claims 8 to 10 wherein the antenna system comprises a rotary antenna, and:

5 the signal receiver unit(s) are arranged to output an RF analogue signal as a response thereof to the applied RF calibration signal;

an optical modulator(s) arranged to receive the analogue RF signal and to modulate an optical signal therewith to produce a modulated analogue optical signal(s);
10

an opto-electrical converter arranged to converting said modulated analogue optical signal(s) into an analogue electrical signal(s);

15 an optical rotary joint including a reversion prism arranged to optically transmit the modulated analogue optical signal(s) from the optical modulator(s) to the opto-electrical converter; and

wherein the calibration controller is arranged to calculate a signal correction(s) according to the analogue electrical signal(s).
20

12. An antenna system according to claim 11 including in which the calibration controller is arranged to apply said RF calibration signal continuously during a 720 degree rotation of azimuth angle of the rotary antenna, and to calculate a plurality of said signal correction(s) corresponding to a plurality of said azimuth angles spanning said 720 degrees.
25

13. An antenna system according to claim 11 or 12 including an analogue-to-digital (A/D) converter arranged to convert said analogue electrical signal(s) into digital electrical signals, and the calibration controller is
30

arranged to calculate said signal correction(s) according to the digital electrical signal(s).

5 14. An antenna system according to claim 13 including an analogue signal processor arranged to receive said analogue electrical signals, and the calibration controller is arranged to control the analogue signal processor to apply a noise reduction correction to said analogue electrical signal(s).

10 15. A computer program or plurality of computer programs arranged such that when executed by a computer system it/they cause the computer system to operate to control an optical signal transmission apparatus in accordance with the method of any of claims 1 to 7, or a machine-readable storage medium storing a said computer program or at least one of said plurality of computer programs.

15

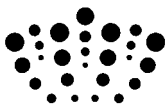

Application No: GB1222609.8
Claims searched: 1 - 15

Examiner: Mr John Watt
Date of search: 9 May 2013

Patents Act 1977: Search Report under Section 17

Documents considered to be relevant:

Category	Relevant to claims	Identity of document and passage or figure of particular relevance
X	1 & 8 at least	GB 2342505 A (NEC) see fig.2 and page 3, lines 11 - 21.
X	1 & 8 at least	US 6157343 A (ANDERSSON ET AL) see figs.4 & 5 and col.4, lines 12 - 43.
X	1 & 8 at least	US 2006/0033655 A1 (QUIVEY) see figs.1 - 8 and paragraphs [0050] - [0053].
X	1 & 8 at least	US 6346910 B1 (ITO) see figs.1 - 3 and col.2, lines 35 - 50.
X	1 & 8 at least	US 2005/0140546 A1 (PARK ET AL) see fig.1 and paragraph [0011].
A	-	GB 2145570 A (GEC) see whole document.
A	-	US 5493304 A (LEE ET AL) see figs.1 - 12 and col.1, lines 12 - 67.

Categories:

X	Document indicating lack of novelty or inventive step	A	Document indicating technological background and/or state of the art.
Y	Document indicating lack of inventive step if combined with one or more other documents of same category.	P	Document published on or after the declared priority date but before the filing date of this invention.
&	Member of the same patent family	E	Patent document published on or after, but with priority date earlier than, the filing date of this application.

Field of Search:

Search of GB, EP, WO & US patent documents classified in the following areas of the UKC^X :

Worldwide search of patent documents classified in the following areas of the IPC

G02B; H01Q; H04B

The following online and other databases have been used in the preparation of this search report

EPODOC, WPI, TXTE

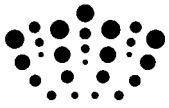

International Classification:

Subclass	Subgroup	Valid From
H01Q	0003/26	01/01/2006
G02B	0006/36	01/01/2006
H04B	0017/00	01/01/2006