

(No Model.)

3 Sheets—Sheet 1.

A. H. PATCH.  
CORN SHELLER.

No. 539,082.

Patented May 14, 1895.

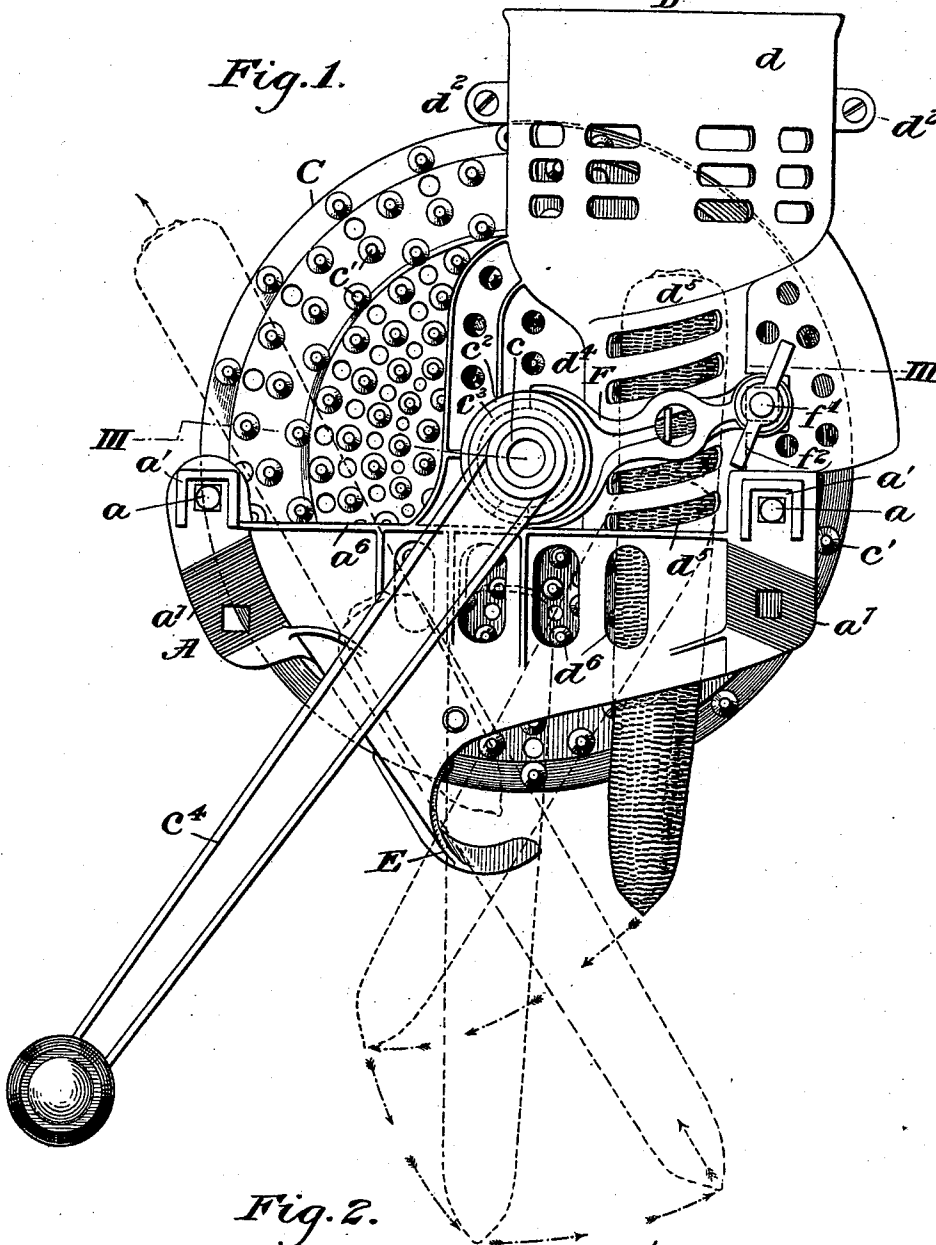
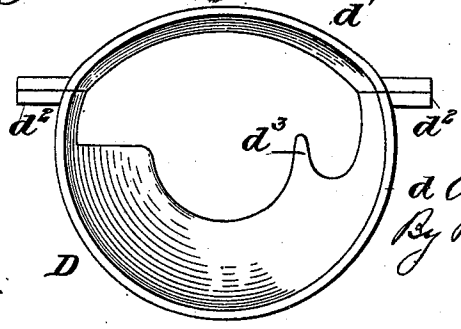

Fig. 2.



Witnesses  
*T. M. Chamberlain*  
*Chas. E. Plimpton*

Inventor  
*A. H. Patch*  
 By *Butterworth & Dowell*  
 his Attorneys.

A. H. PATCH.  
CORN SHELLER.

No. 539,082.

Patented May 14, 1895.

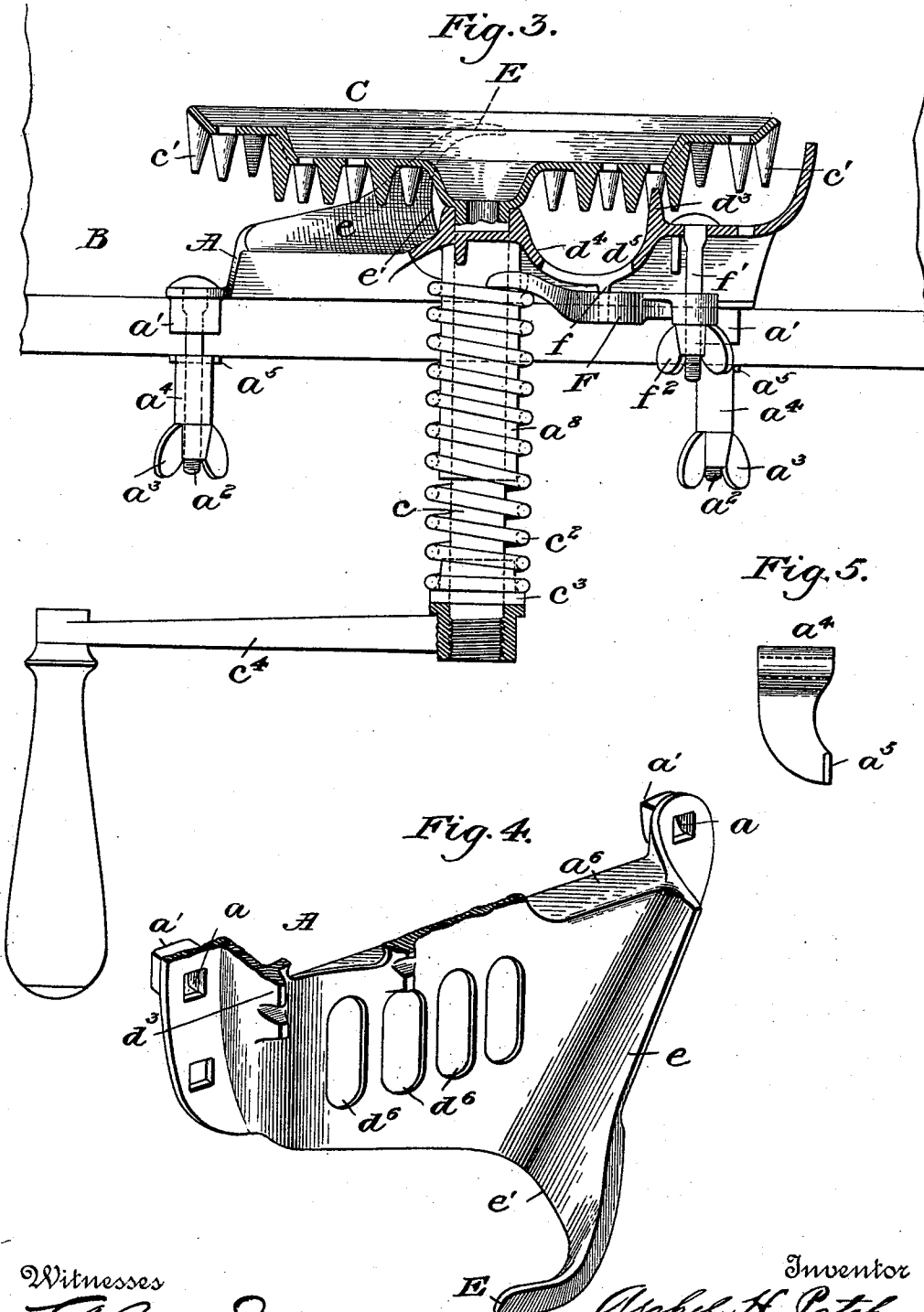

Witnesses  
*J. A. Comery*  
*Chas. E. Riordan*

Inventor  
*Ashel H. Patch*  
 By *Buttworth & Dowell*  
 his Attorneys.

A. H. PATCH.  
CORN SHELLER.

No. 539,082.

Patented May 14, 1895.

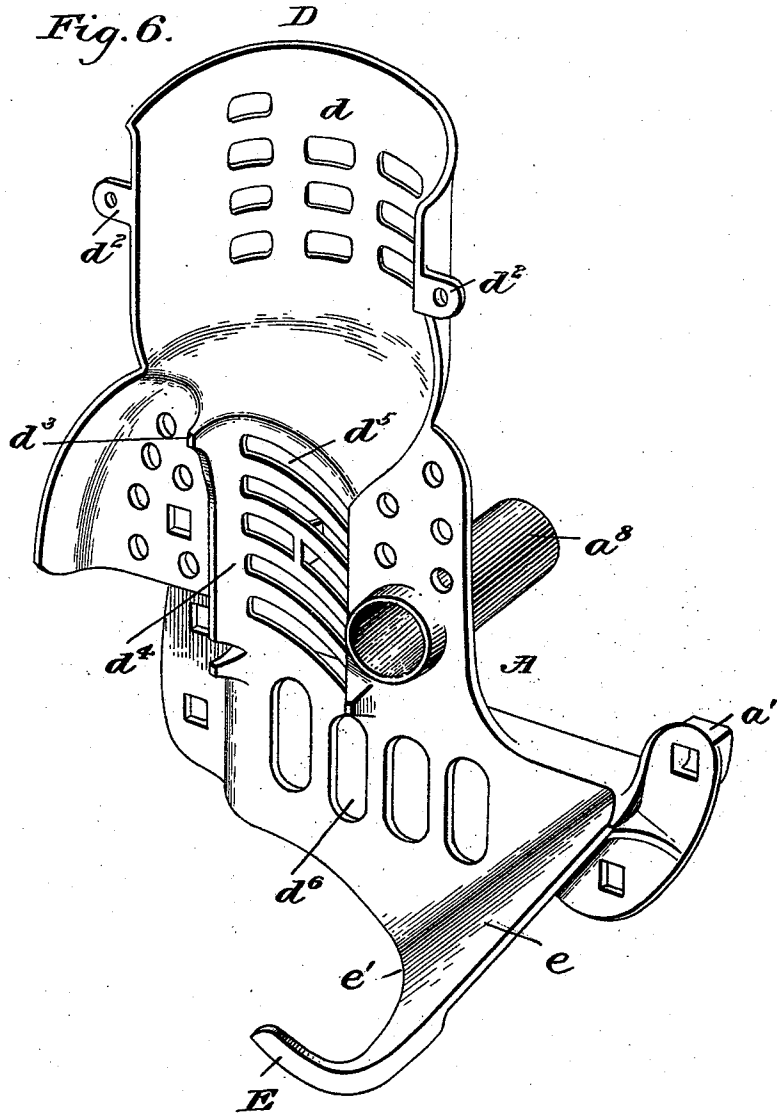

Witnesses

*T. A. Sommers*  
*Chas. E. Riddon*

Inventor

*Asahel H. Patch*  
By *Buttsworth & Dowell*  
his Attorneys

# UNITED STATES PATENT OFFICE.

ASAHEL H. PATCH, OF CLARKSVILLE, TENNESSEE.

## CORN-SHELLER.

SPECIFICATION forming part of Letters Patent No. 539,082, dated May 14, 1895.

Application filed January 23, 1895. Serial No. 535,944. (No model.)

*To all whom it may concern:*

Be it known that I, ASAHEL H. PATCH, a citizen of the United States, residing at Clarksville, in the county of Montgomery and State of Tennessee, have invented certain new and useful Improvements in Corn-Shellers; and I do hereby declare the following to be a full, clear, and exact description of the invention, such as will enable others skilled in the art to which it appertains to make and use the same.

This invention relates to corn shellers such as are employed for domestic use, and more particularly to hand-operated as distinguished from power machines.

The primary objects of my invention are to produce a simple, light, efficient and inexpensive hand-operated corn sheller by which the grains of corn can be easily and readily separated from the cob and the cobs separated from the shelled corn, and to so construct and arrange the parts that very little or no hand-finished or machine work is necessary to properly assemble the parts, and also to employ as few parts as possible consistent with the production of an efficient, durable and operative device, so as to reduce the cost of such machines to a minimum.

A further object is to provide simple and convenient means for yieldingly holding the co-acting corn shelling parts together and for varying the pressure between said parts so as to readily compensate for ears of different sizes, and also to permit an easy and convenient adjustment of the parts for varying the pressure in shelling old and new corn or corn requiring more or less pressure to thoroughly separate the grains of corn from the cob.

Another object is to provide improved means whereby the cob is positively but yieldingly held and guided in its movements and at the same time is prevented from being jammed or wedged in between the toothed face of the rotating disk and the lower portion of the frame as it is being carried laterally butt end foremost in ejecting it from the machine.

The invention will first be hereinafter more particularly described with reference to the accompanying drawings, forming a part of this specification, and then pointed out in the claims at the end of the description.

In the drawings, Figure 1 is a front elevation of my improved corn-sheller, illustrating in full and dotted lines the different positions the ear of corn assumes in its descent and as it is being carried laterally and upwardly for ejection from the machine. Fig. 2 is a detail plan view of the hopper. Fig. 3 is a sectional plan on the line III III of Fig. 1, showing the frame clamped to a suitable receptacle to receive the separated grain. Fig. 4 is a fragmentary perspective view of the lower portion of the main frame-piece of the machine, illustrating a rear view of the cobchute with fulcrum plate or guard and guide-finger integral therewith. Fig. 5 is a side elevation of one of the clamps; and Fig. 6 is an inside perspective view, looking from the rear of the machine, of the main frame and guide for controlling and directing the ears of corn in their passage through the machine.

The main guiding and holding frame A, is preferably cast of malleable iron or steel, in the form shown, though other forms may be employed. It is provided with apertures  $a, a$ , and extensions  $a', a'$ , which may partially surround said apertures; the latter serving to hold the clamp-bolts  $a^1, a^2$ , which pass horizontally through said apertures. These bolts are provided with nuts  $a^3, a^3$ , and have loosely arranged thereon suitable clamps  $a^4, a^4$ , the depending ends  $a^5, a^5$ , of which are adapted to bind the edge of a suitable grain receptacle B between said clamps and the front surface of the frame A; but it is obvious that bolts for this purpose may pass through suitable apertures in the frame and receptacle for permanently holding the two together if so desired. The frame A may also be formed or cast with a series of vertically disposed openings  $a^6$  and with a strengthening rib  $a^6$  and roughened surfaces as at  $a^7$ , on opposite sides of the center of the frame, which afford sufficient bearing surface to rigidly hold the frame when the same is secured to the grain receptacle. Extending outwardly from the frame A is an apertured bearing or sleeve  $a^8$ , preferably cast or formed integrally therewith, and through which passes the spindle or shaft  $c$  of a toothed disk C.

For controlling and directing the ear of corn while it is being subjected to the action of the toothed disk, I provide a suitable guide, which

may be formed integrally with the frame A and is arranged to stand across the face of said toothed disk at one side of the center thereof; said guide being constructed of two diameters, the larger or upper segment  $d$ , extending slightly above the toothed disk and having a concave or semi-cylindrical plate  $d'$  secured thereto, so as to form a hopper D, for introducing the ears of corn, while the smaller or semi-cylindrical portion  $d^4$ , of the guide stands opposite the toothed face of the disk. Between the larger and smaller segments of this guide and at their junction is formed an incline or shoulder at one side of which on the inside of the guide  $d^4$  is formed an inwardly projecting tooth  $d^3$ . The hopper D has its enlarged front section  $d$  preferably cast or formed integrally with the frame A and the lower reduced section or segment  $d^4$ , and the rear portion or attached section  $d'$  thereof may be secured thereto by bolts passing through lugs or projections  $d^2, d^2$ , formed upon the two sections. The enlarged upper portion of the hopper section may be provided with a series of openings, if desired, arranged substantially as shown in Figs. 1 and 6, to give lightness to the structure, and its lower reduced or semi-cylindrical portion  $d^4$ , may be provided with a series of spirally arranged or inclined openings  $d^3$ , with intervening ribs or equivalent means, adapted to retard the downward passage of the ear of corn and at the same time permit the longitudinal movement of the cob while the latter is rotating under the influence of the toothed disk; said openings and intervening ribs thus formed serving also to assist in removing any grains of corn which may remain adhering to the cob.

The lower portion of the frame A is formed or provided with an inclined chute  $e$ , the base or foot  $e'$  of which serves as a guard or fulcrum against which the cob may abut on its descending movement so that as the butt end of the cob is being carried laterally under the axis of the disk and its rotary movement reversed it may also be tilted or turned at an angle to its descending path of movement and carried upwardly so as to be ejected from the opposite side of the machine. Owing to the convexity of the disk or the inclination of its marginal working face, the cob, on being reversed, is liable to be tilted and jammed or wedged in between the toothed disk and frame, on starting upward after its direction of motion has been reversed, and to prevent this action a finger E is provided or formed integrally with the guard-plate  $e'$  so as to extend around and partially embrace the cob; said finger being adapted to guide and control the movements of the cob so as to prevent the same from tilting and causing its lower end to be thrown outward when it has reached the limit of its descending movement and is in the act of being reversed, whereby the jamming or wedging action which would otherwise result on the reverse movement is avoided.

The toothed disk C is preferably of such form that the face of its outer margin may be provided with an inclined or beveled working surface; but other forms may be employed if desired. In the form shown the central portion of the disk is provided with pins or teeth of substantially uniform height, while the margin of the face of the disk is formed with an offset and bevel upon which are located the outer series of teeth or pins. The points of the pins or teeth  $c'$  which are located upon the offset portion of the disk stand slightly in rear of the teeth on the central portion thereof, and the points of the teeth constituting the extreme outer series and located upon the bevel at the edge of the disk stand slightly in rear of the teeth of the next inner series located upon the offset portion. The effect of this arrangement is to produce a toothed disk substantially flat at the center, measured by the top or points of the teeth, and inclining rearwardly at the edge. This disk C is yieldingly pressed toward the frame by a suitable spring  $c^2$  which in the present instance surrounds the sleeve  $a^8$ , and has its forward end abutting against a washer  $c^3$ , which is loosely held on the stem or spindle  $c$  by a suitable handle  $c^4$ ; the said handle being preferably secured to the end of said stem by a screw thread, though any other suitable means may be employed for this purpose.

For the purpose of varying the pressure between the frame A and the disk C, I may employ a lever F loosely pivoted to or fulcrumed upon a projection  $f$  on the frame of the machine and having one of its ends bifurcated to partially span the sleeve or bearing  $a^8$  so as to engage the inner end of the spring  $c^2$  against which said spring rests. The other end of the lever F is provided with an aperture through which passes a bolt  $f'$  extending outwardly from the frame A and provided on its outer screw threaded end with a suitable nut  $f^2$  for tilting said lever on its pivot, whereby the pressure of the spring may be increased or diminished at will by turning the nut  $f^2$  in the desired direction. By this means I may readily vary the pressure with which the toothed disk is forced toward the frame and cob-guiding and delivering devices, to suit the requirements of the corn that is being shelled, and by reason of the leverage afforded by the lever F and the sweep of said lever the desired adjustment may be easily and quickly effected.

The operation of the machine thus constructed is briefly as follows: The point or tip of the ear of corn is introduced into the hopper formed by the cavity in the frame and the inclined edge or face of the toothed disk on the one side, and the upper and larger diameter  $d$  of the guide or shell and the shoulder at the junction of the upper and lower sections of said guide or shell. The toothed disk being rotated by means of a crank, the teeth on the disk engaging the corn at the

point of the ear operate to both rotate the ear of corn and at the same time separate and remove the kernels therefrom. Owing to the position of the guide or shell with relation to the face of the toothed disk the teeth of the latter traverse in contact with the ear of corn in inclined planes, and as the grains of corn are removed the cob is carried downward between the toothed disk and the lower or smaller section  $d^4$  of the guide, by which latter the ear is maintained in position to traverse across the face of the toothed disk. The inclined or spiral ribs formed by the openings  $d^3$ , or similarly formed ribs on the inner face of the reduced section of the guide, operate to retard but at the same time permit the longitudinal movement of the cob while the latter is rotating under the influence of the toothed disk, and they also serve to assist in removing any grains of corn which may remain adhering to the cob. During its passage across the face of the toothed wheel the ear of corn is continuously rotating about its own axis, and at the same time is progressed longitudinally, while being held up into engagement with the teeth on the disk by the action of the spring  $c^2$  which tends to constantly press and hold the ear of corn between the toothed face of the disk and the shell or frame with attached cob-guiding and delivering devices. As the cob descends through the reduced section  $d^4$  of the guide its point is carried down beyond the end of the plate or chute  $e$ , and the butt end thereof—held by its engagement with the teeth on the face of the disk—is carried laterally under the axis of the disk, thereby drawing the cob in a reverse direction up the inclined plate or chute  $e$ ; the cob being fulcrumed in the meantime upon the guard-plate  $e'$ , and guided and held in proper alignment by the guard finger  $E$ , so as to insure its proper passage up the inclined chute without danger of being wedged in between the frame and toothed wheel on the reverse movement. Owing to the curved formation of the butt end or top of the ears of corn any grains that may adhere thereto after the cob has passed below the reduced section of the shell are removed by the ribs formed by the openings  $d^3$  in the frame  $A$  underneath the axis of rotation of the disk. The cob is aligned and retained against displacement by the finger  $E$  both prior to and during its passage up the inclined chute, and on reaching the summit of its reverse movement it is projected from the machine and separated from the kernels of corn which fall down by gravity into a hopper or receptacle below the machine.

While I prefer to cast the parts of the machine of malleable iron or steel, I may make them of any suitable material and in any preferred manner; but by casting the machine in the form shown no machine work or hand-finished work other than the screw-thread on the stem  $c$  and in the handle  $c^4$  is necessary, thereby permitting the parts to be assembled

as cast, thus reducing the cost of production to a minimum and also the cost of repairs, as a broken or injured part may be readily replaced at a small cost.

The general contour of the hopper and guide or shell shown herein is substantially similar to the shell shown in a patent heretofore issued to me, to wit., Patent No. 353,080, granted November 23, 1886, for improvements in corn shellers, and the toothed wheel shown herein is also similar to the wheel shown in said patent, and hence I do not claim broadly herein either of these two features of construction.

Having thus fully described my invention, what I claim as new, and desire to secure by Letters Patent of the United States, is—

1. In a corn sheller, the combination with a frame having an inclined cob-delivering chute, of a toothed wheel yieldingly held to said frame and having a beveled or inclined marginal working face, and a cob-guiding and aligning finger extending outwardly from the lower portion of said inclined chute and adapted to operate in conjunction with said wheel to prevent the cob from being wedged in between said frame and wheel when it is being reversed and ejected from the machine, substantially as described.

2. In a corn sheller, the combination with a frame, of a hopper arranged on said frame, a toothed wheel rotatably held in the frame, a spring yieldingly holding said wheel and frame together, a lever pivoted to the frame and having one of its ends engaging the spring, and means for tilting the lever on its pivot so as to vary the tension of said spring, substantially as described.

3. In a corn sheller, the combination with a frame, of a hopper arranged on said frame, a toothed wheel having a shaft journaled in the frame, a spring surrounding the shaft tending normally to force the wheel toward said frame, together with a lever pivoted to the frame and engaging the spring with one of its ends and having its other end engaged by a bolt for tilting said lever on its pivot to vary the tension of said spring, substantially as described.

4. In a corn sheller, the combination with a frame, of a rotatable toothed wheel having a bearing in said frame, a yielding connection between said wheel and frame, and a hopper and guide comprising two sections rigidly secured together, one of said sections being formed integrally with the frame and provided with an enlarged upper hopper portion and a reduced lower portion or guide having a series of inclined openings to provide intervening inclined ribs; said frame also having a series of vertically disposed openings forming intervening ribs arranged at an angle to and on a lower plane than said inclined ribs substantially as described.

5. In a corn sheller, the combination with the frame, of a clamping device for securing the same to a receptacle, comprising a bolt or

bolts passing through apertures in said frame, the latter having extensions or projecting flanges partially surrounding said bolts, a clamp or clamps having one end loosely held on said bolt and having a depending end adapted to engage the edge of the grain receptacle and a nut on said bolt for tightening said clamp, substantially as described.

6. In a corn shelling machine, the frame having the inclined cob-ejecting chute and guide finger projecting from its lower portion and a series of vertically disposed openings above said finger, together with an enlarged semi-cylindrical hopper portion and an inter-

mediate reduced concave guide portion provided with a series of transverse inclined openings or ribs, in combination with a toothed disk having a beveled or inclined marginal working face journaled in said frame and means for yieldingly pressing said disk toward said frame, substantially as described.

In testimony whereof I affix my signature in presence of two witnesses.

ASAHEL H. PATCH.

Witnesses:

CHAS. E. RIORDON,  
J. A. E. CRISWELL.