

(19)
(12)

(KR)
(A)

(51) 。 Int. Cl.7
A45D 40/26

(11)
(43)

10-2004-0071617
2004 08 12

(21) 10-2004-0006866
(22) 2004 02 03

(30) 0301269 2003 02 04 (FR)

(71) , F-75008, 14

(72) -
75016 27

(74)

:

(54)

(5) , : (10);
(11) ,

1

,

1

2

1

;

3 1 가 ;

4 가 ;

5 4 ;

6 ;

7 가 가 ;

8, 9, 9a ;

10 12 , ;

13 가 가 ;

13a 13b 가 ;

14 ;

15 ;

16 가 15 , ;

17 ;

18 가 17 , ;

19 26 가 ;

27 가 ;

28 29 ;

30 가 , 29 ;

31 - ;

32 3 , ;

33 3 , ;

34 51 ;

52 55 ;

56 .

cators) (keratinous fibers), (mascara brushes) (appli

4,561,456

가

가

1

(extended in oriented manner)'

가 가

(implantations)

가 가 가

가 (stem) (distal end) 가

(proximal end)

6,227,735

(taken in charge)

가

EP-A-1 155,637

(punc

hed) , (stapled) .

, (obliquely)' 가 .

, (peaks) (notches) .

20%, 가 50%, 80% ,

가 , 180° 5 60 .

, 가 .

, (coating of flocking) .

ess) (filler), (roughn

5/100 (mm) 35/100 mm 가 (diameter)'

, 1 mm 7 mm , 2 mm 5 mm

, 가 ,

가 가 , (vitreous transition temperature)

, , , , (indentati

on) , , , , (extremum)

, () , ,

(sticking) : (graphite) (PTFE),
가 가 가

가

가

가 가 ;

가 , 가

가 , 가

가 , 80 , 220

50 , 6/6, 6/10, 6/12, 11 , 1

가 , 100 rpm , 1200 rpm

1 (2), X (1) , 가 (P), (2)

(4a) (5) (3) (neck) (7)

(6)가 (6) 가 (4) (thread)

(4) (5)가 (8) (4) (8)가

(7) (lip) (9) (8)

(foam) (slots) 가

(4)

가 (4) (3) (a

articulated connection) (ball-and-socket joint)

4) (5) 가 (10) (10) (

(force-fit)

(5) 2 3 (10) 가

(clamped) (3) 3

(5) 2 (11)

2

1 2 2 가 2 1 1

, 3 1, 4 1

3/4, 2/3, 1/2

1 3 (20) (4) (21)

) X (21) Y 가 (21 (20) (5) (20)

(20) , , , ,

4 (20) Y
2 (5a) Y 4
Y

(20) , (21) , (20) (22)
가 (11) 가

(21) 6/6
150

(21) 150 (jaw) (31)
6/6 (30) 1000 rpm

(20) (21) (23) (21)

6 7 (20)가 가
, ' ' , ' '

6 가 , (20) Y
가 , .
8 (21) (20)가, , (21) Y 가
(21) (21) ,
(14) , 9 ,
(21) (21a 21b) (5)
(21a 21b) (21a 21b)
, 9a , (20)가, (21a 21b) ,
(20a 20b) .
가 (21) , (21)
, 10 , 12 ,
가 가 ,
4, 6, 8, 9 9a , Y (20)
가 .
(5)가 (20)가 , 1
s', 가 , 2 s' (13).
, 가 s' s' s'
가 s' s'
가 .
가 , 13b , 가 , 가
(11a) (11b) 14
(11a) 가 (21) , (11b) 가
, 15 , Y 가 ,
16 , 가 ,
17 .
, 18 가 가

19 26 , 가 .
 , 19 , 20 .
 21 .
 22 가 (indentation)
 가 , .
 23 , (facet) (42) 가 .
 24 (notch) (43), 3 가 .
 25 (43) , 26 .
 (10) , , .
 , 27 가 .
 , .
 가 , 가 , 가
 , 28 , (extremum)
 (45) , .
 29 , (46) (47) .
 , 29 30 , 가 (48) , .
 (5) 31 , (4) (4a) (bend) (49)
 가 , .
 , 32 .
 / , , .
 33 , .
 , .
 , 34 51 , 34
 3 가 , 35 , 36 37
 T- , 38 U- , 39 H- , 40
 , 41 V- , 42 , 44
 43 (ramification) ,
 , 45 (oblong) , 46
 , 47 , 48
 49 가 .
 , 50 (hinged) 가
 , 51 (capillary groove) (60)
 가 , 52 ,

(beads) , 53 (forks) (62) 가 .
, 54 (microrelief) , 55 가 .

Rilsan ® , Hytrel ® -Pebax ® , 가 PA6, PA6/6, PA6/10, PA6/12, PA11,

, 56 (10', 10') 가 (10' 10')

(sheathed) 가 가 , 가

(57)

1.

- (10);

- (11) ;

2.

1 ,

3.

1 2 ,

4.

3 , , ,

- 3 5. , , , , .
- 1 6. 5 , , .
- 1 7. 6 , 20%가 .
- 1 8. 7 , 50%가 .
- 1 9. 8 , 80%가 .
- 1 10. 9 , 가 , 5
60 .
- 1 11. 10 , 가 .
- 1 12. 11 , 5/100 mm 35/100 mm .
- 1 13. 12 , 1 mm 7 mm .
- 1 14. 13 , 2 mm 5 mm .
- 1 15. 14 , 가 .
- 1 16. 15 , 가 .
- 13 17. , 가 , .
- 16 18. , 가 (vitreous transition temperature)
가 ,가 .
- 1 19. , .

20.

: , ,

-

21.

20 , 가 .

22.

20 , (21)

23.

22 , : , - , (PTFE),

24.

20 21 , 가 (Y)

25.

20 24 , (21) (20)

26.

25 , (20)가 , 가

27.

20 27 , (21)

28.

20 , .

29.

, 20 28

- (5) (30, 31);

- (20) , :

- (21);

- 가 가 (22);

- , (20) (21)

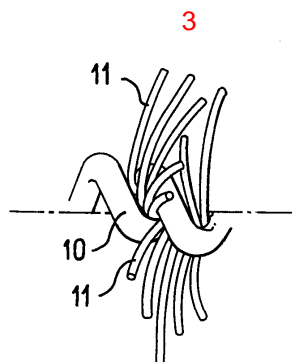
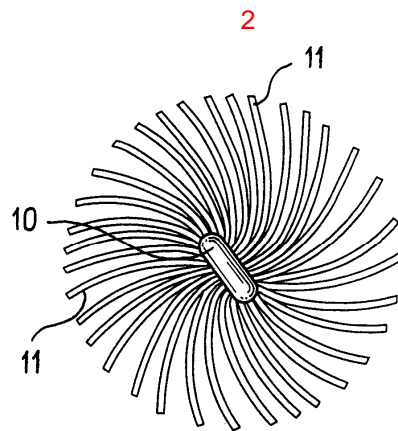
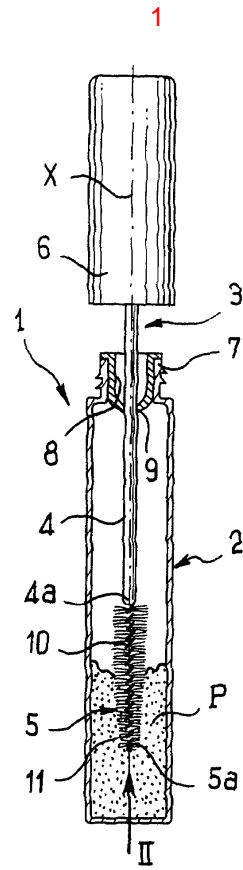

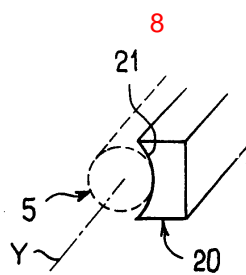
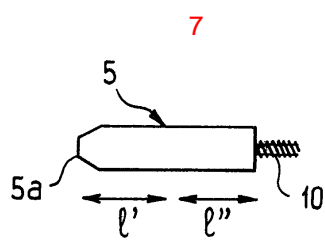
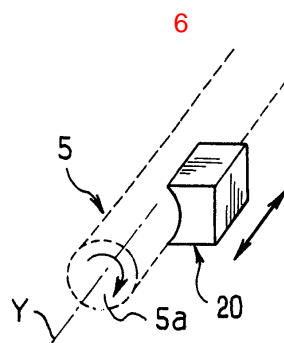
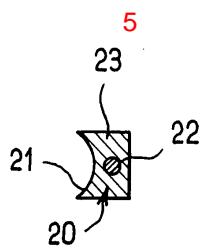
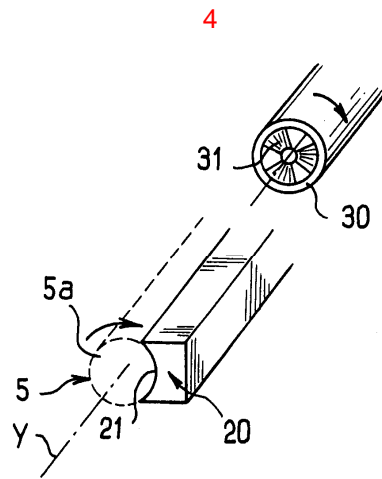

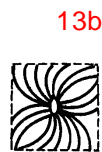
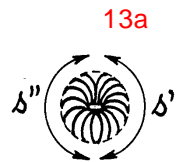
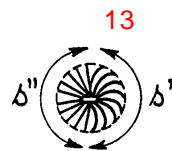
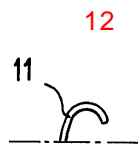
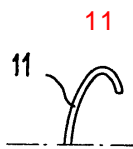
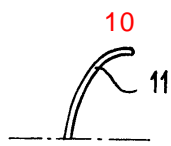
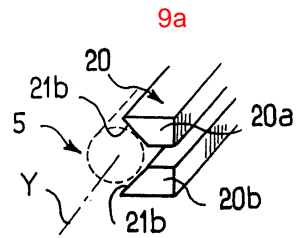
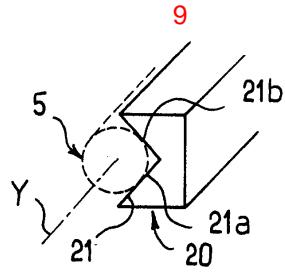

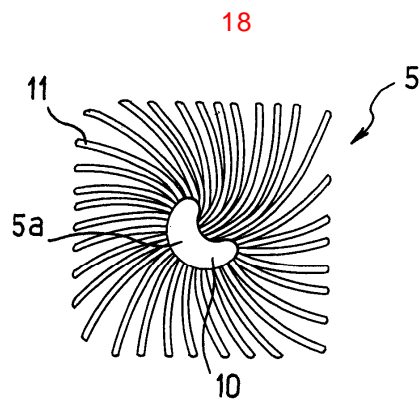
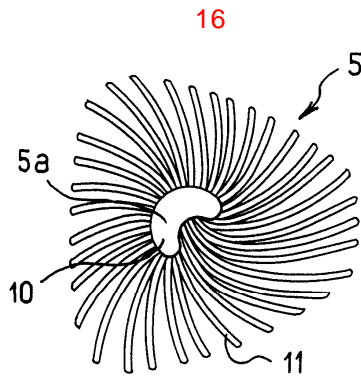
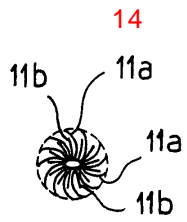

21



22



23



24



25



26



27

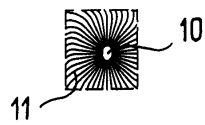

28

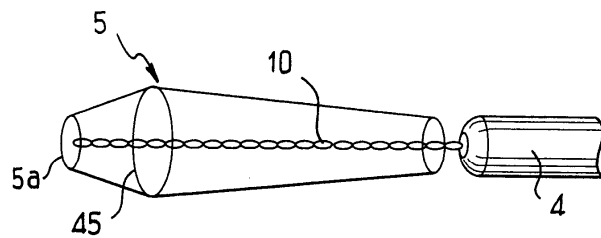

29

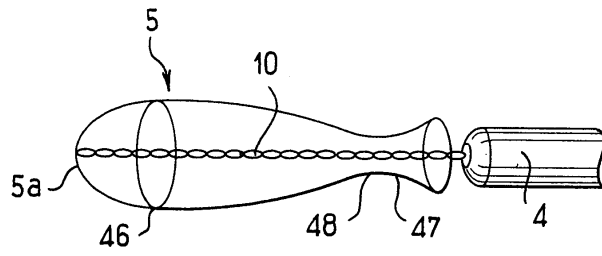

30

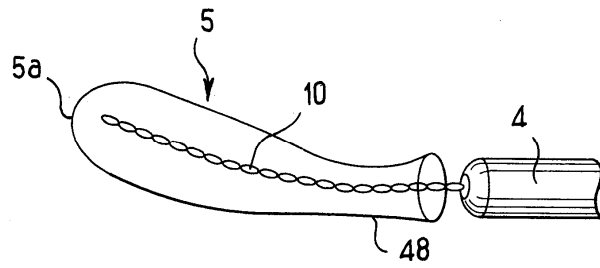

31

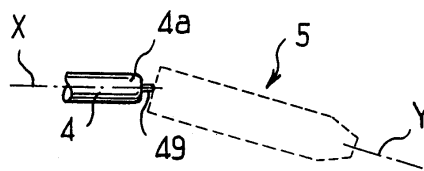

32

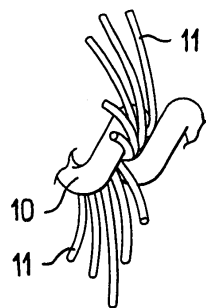

33

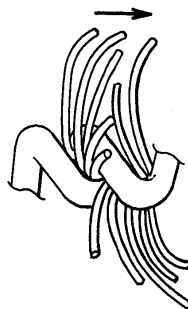

34



35



36



37



38



39



40



41



42



43



44



45



46



47



48



49



50



51



52



53

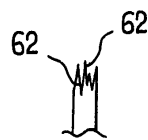

54



55

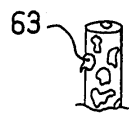

56

