



US 20040099665A1

(19) **United States**

(12) **Patent Application Publication**

McEldowney et al.

(10) **Pub. No.: US 2004/0099665 A1**

(43) **Pub. Date: May 27, 2004**

(54) **EASY-OPENING CAN END AND A
CONVERSION PRESS AND TOOLS FOR
PRODUCING THE SAME**

Publication Classification

(51) **Int. Cl.⁷ B65D 17/40**

(52) **U.S. Cl. 220/270; 220/276; 413/14;
413/25; 413/66**

(76) **Inventors: Carl F. McEldowney, Ansonia, OH
(US); Mark R. Mitchell, Sidney, OH
(US)**

(57) **ABSTRACT**

Correspondence Address:
**ECKERT SEAMANS CHERIN & MOLLETT,
LLC
ALCOA TECHNICAL CENTER
100 TECHNICAL DRIVE
ALCOA CENTER, PA 15069-0001 (US)**

An easy-opening can end and tools for making the same in which the can end is intended for cans of food products or other non-pourable products in which the can end has an improved pull tab attached to a relatively large removable panel portion and in which the tab has a bending fulcrum behind the rivet to facilitate severance of the score around the removable panel. The tab has a C-shaped slot in it around the side of the rivet toward the center of the can end to permit limited bending of the tab along the fulcrum line.

(21) **Appl. No.: 10/305,455**

(22) **Filed: Nov. 27, 2002**

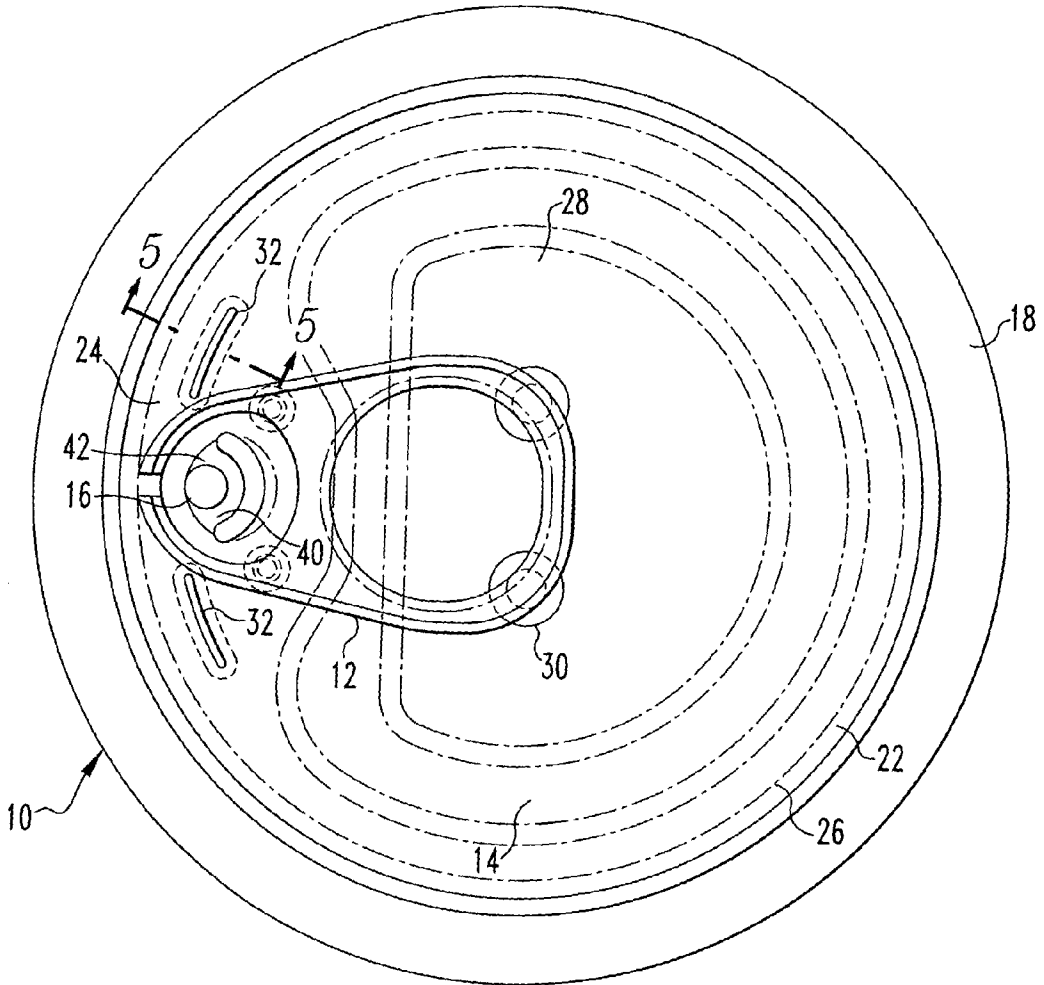

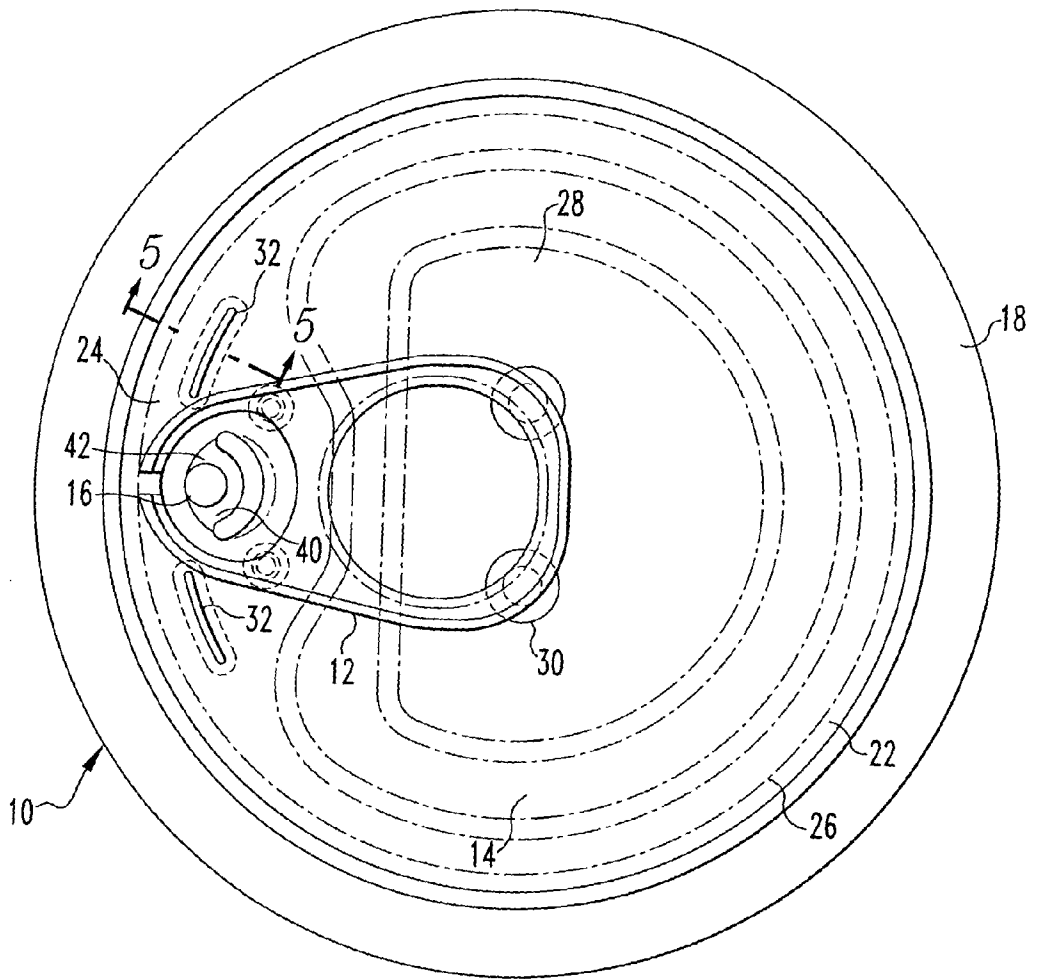

FIG. 1

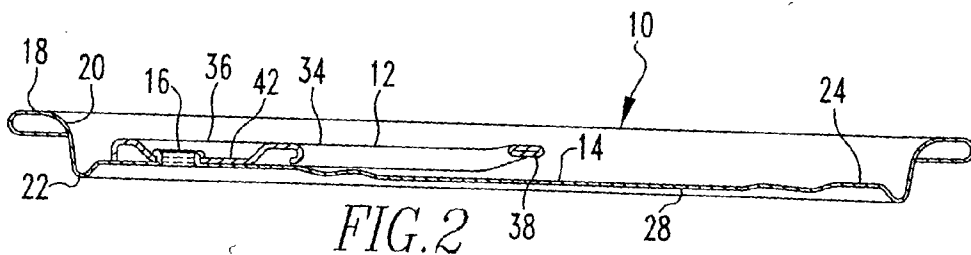

FIG. 2

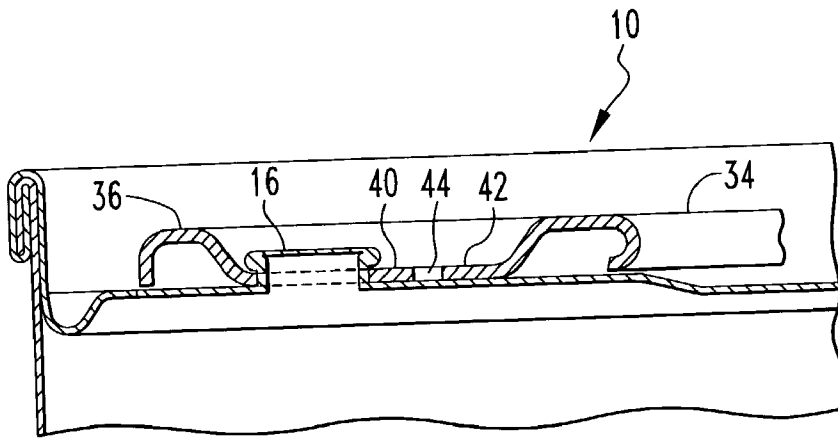

FIG. 3

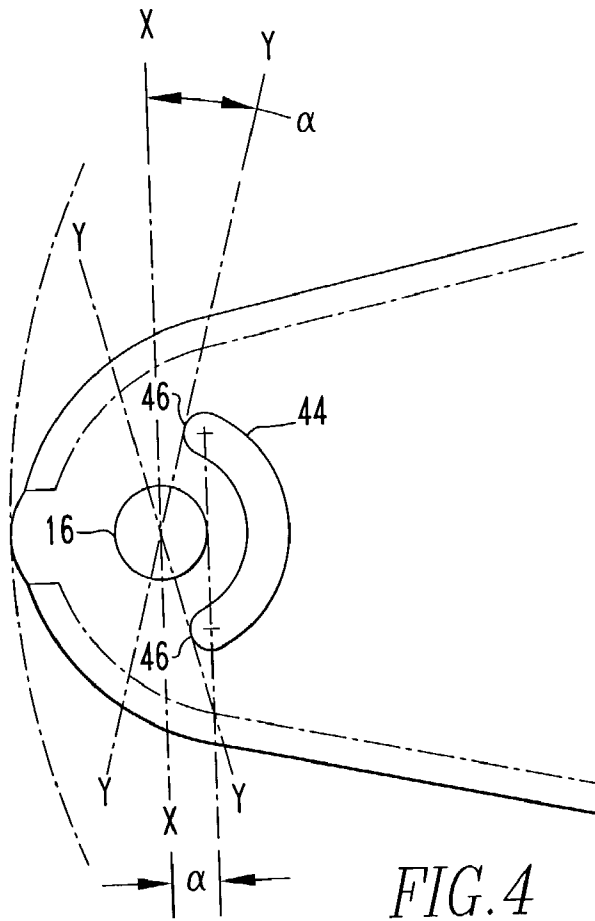

FIG. 4

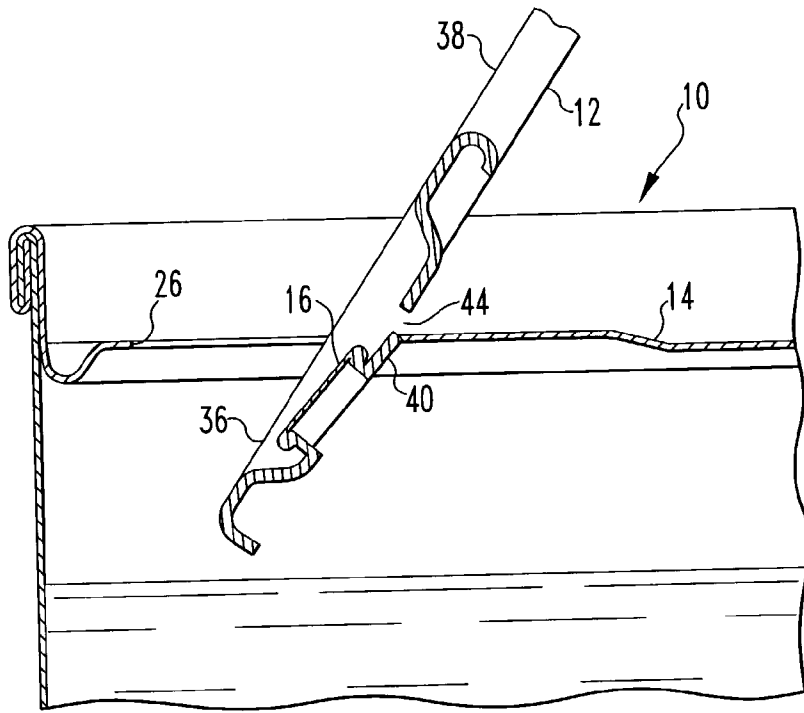

FIG. 7

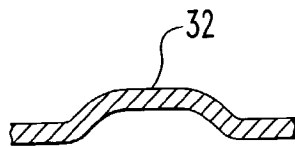

FIG. 5

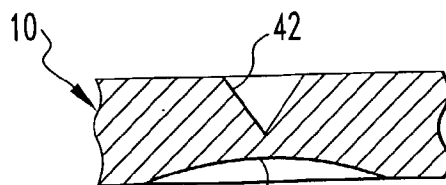

FIG. 6

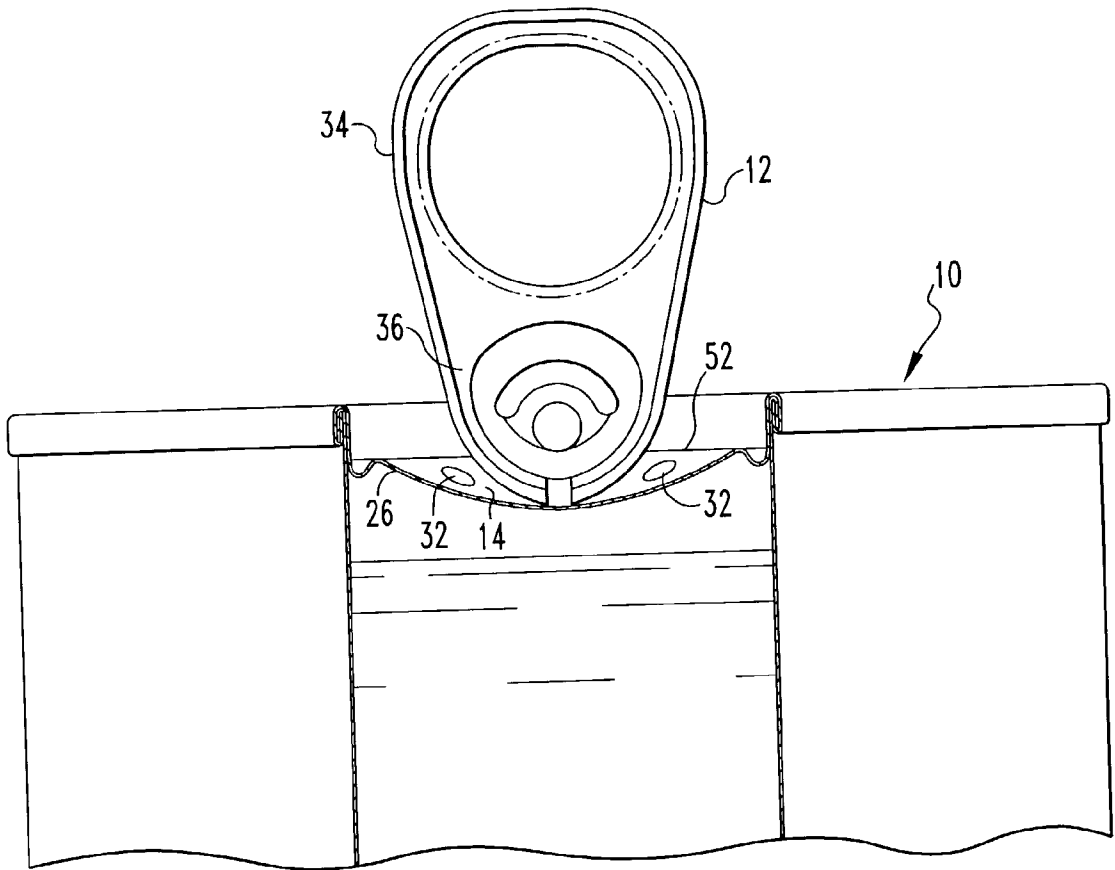

FIG. 8

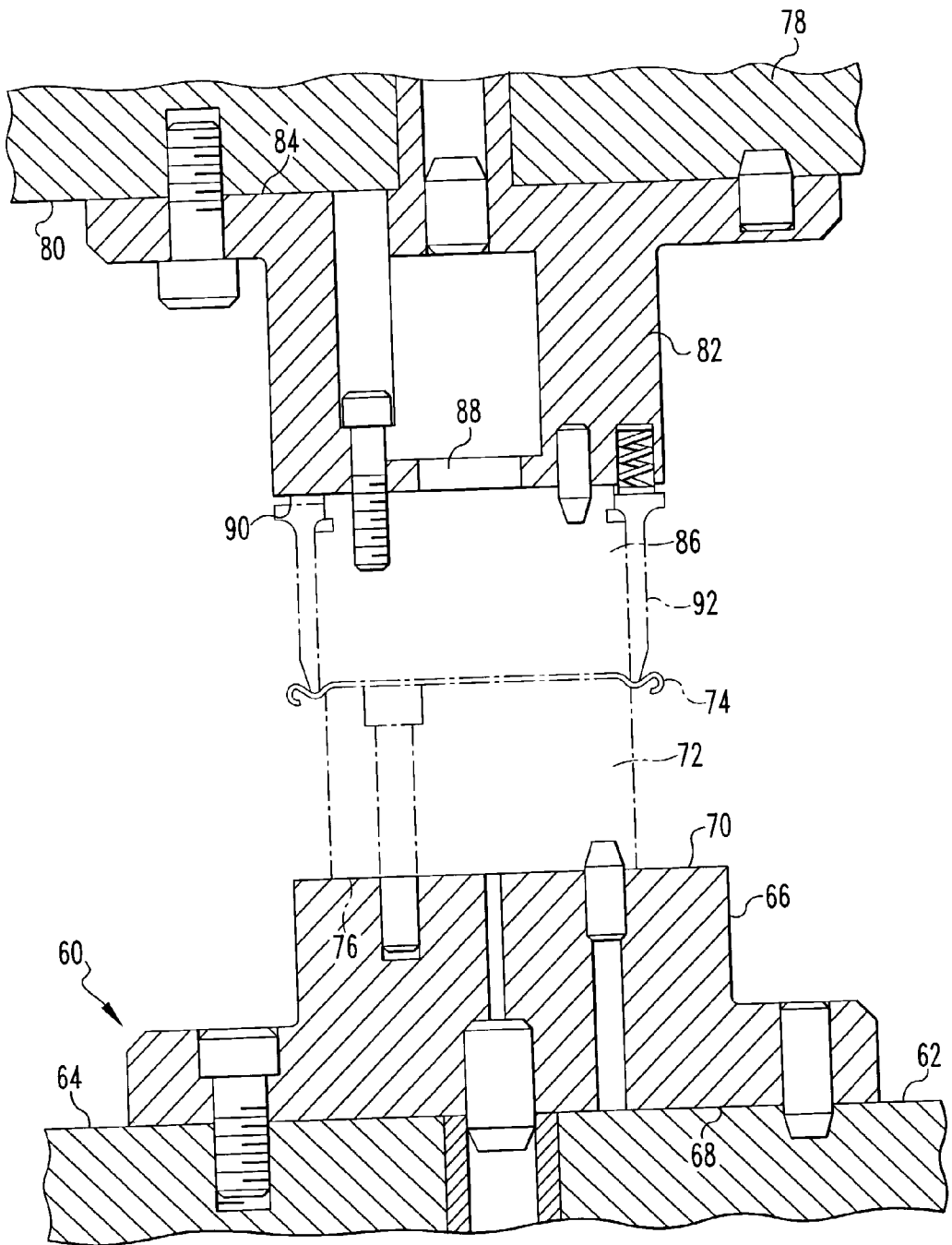

FIG. 9

EASY-OPENING CAN END AND A CONVERSION PRESS AND TOOLS FOR PRODUCING THE SAME

FIELD OF THE INVENTION

[0001] This invention relates to easy-opening can ends having relatively large removable panel portions for cans of food products and the like and to pull tabs for such can ends and to a conversion press and tools for manufacturing such can end.

DESCRIPTION OF THE PRIOR ART

[0002] Easy-opening ends for cans for a great variety of products such as foods, beer and beverages are well known in the arts. The can ends may have relatively large removable panel portions for cans of food products or may have smaller partially removable panel portions for pourable products like beer and beverages. The can ends and can bodies are typically made of aluminum sheet metal, but some are made of tin plate steel sheet metal.

[0003] In the manufacture of an easy-open can end, a can end shell is first formed from a metal sheet product, preferably an aluminum sheet product. The can end shell is then conveyed to a conversion press. In the typical operation of a conversion press, a can end shell is introduced between an upper tool member and a lower tool member which are in the open, spaced apart position. A press ram advances the upper tool member toward the lower tool member in order to perform any of a variety of tooling operations such as rivet forming, paneling, scoring, embossing, tab securing, and final staking. After performing a tooling operation, the press ram retracts until the upper tool member and lower tool member are once again in the open, spaced apart position. The partially converted shell is transported to the next successive tooling operation until an easy-open can end is completely formed and discharged from the press. As one shell leaves a given tooling operation, another shell is introduced to the vacated operation, thus continuously repeating the entire easy-open can end manufacturing process.

[0004] Easy-opening can ends conventionally have a score line or score lines indented into the metal of the central panel portion to define removable or partially removable panel portions in the ends and have pull tabs attached to the removable panel portions by means of rivets formed integrally from the sheet metal of the can ends. The so-called integral rivets are typically one-eighth to one-quarter inch in diameter before being staked to attach the pull tab to the can end.

[0005] A great variety of pull tabs and can ends have been developed and used in the can industry. It is desirable to ease lifting of the pull tab to initiate opening of the can end and can and also desirable to minimize failure of the easy-opening ends by tab pull off. It is further desirable to minimize the amount of metal used in easy-opening can ends, including the pull tabs on such ends. Reduction in the metal usage may involve reduction in the thickness of the sheet metal used and/or reductions in the area of the sheet metal used.

[0006] Easy-opening ends for food cans typically have a continuous primary score line completely around the central panel portion of the can end and may have one or more

anti-fracture score lines closely adjacent the primary score line. Such easy-opening ends may also have a moustache score adjacent to the attachment rivet to facilitate initiation of rupture of the primary score line around the removable panel portion; see for example U.S. Pat. Nos. 5,052,573 (Zysset), 4,002,262 (Khoury) and 3,544,025 (La Croce). Other easy-opening ends having large removable panel portions do not include moustache scores; see for example U.S. Pat. Nos. 5,671,860 (Louwerse et al.) and 3,838,788 (Stargell).

[0007] An improved easy-opening end for food products is needed to reduce the pull force required to rupture the score line around the removable panel and also to reduce metal usage in the pull tabs on the can ends.

SUMMARY OF THE INVENTION

[0008] The present invention is directed to an improved pull tab for easy-opening ends having relatively large removable panels and also to improved easy-opening ends having such pull tabs on them, and to conversion presses and tools for converting can end shells into such easy-opening ends. Improved pull tabs and can ends of this invention have the bending fulcrum of the tab on the end behind the rivet attachment to the removable panel. The word "behind" as used herein means toward the center of the removable panel from the rivet attachment. This invention also preferably uses a one-eighth inch rivet, but may also use a larger rivet or even possibly a smaller rivet.

[0009] The pull tab of this invention preferably has a nose end portion and a handle end portion with a reinforcing curl or bead substantially around the entire tab. The tab further has a C-shaped lance or C-shaped slot around the rear portion of the rivet attachment portion or tongue in the tab. The ends of the C-shaped lance or slot are preferably located behind (toward the center of the can end) a transverse line across the tab through the center of the rivet attachment. In one preferred embodiment, lines through the ends of C-shaped slot and the center of the rivet form angles of about 10-12 degrees to the transverse line through the center of the rivet attachment.

[0010] This invention facilitates location of the attachment rivet closer to the score line around the removable panel than with prior art ends and also produces a relatively large bending chord across the removable panel. This invention reduces pull forces required to open the end. Easy-opening ends of this invention also have more consistent pull valves on forces. This invention also increases the number of tab bends that a tab will withstand and facilitates openability even when a user lifts the tab from the side of the tab instead of the end of the tab. This invention also reduces tongue tears, or tearing of the tongue of metal in which the attachment rivet is located. A further advantage of this invention is that it facilitates down gauging of the metal used to make the pull tabs.

[0011] Accordingly, it is an object of this invention to provide an improved pull tab and can end that can be opened with pop equal to that of prior art tabs, and reduced pull force.

[0012] A further object of this invention is to provide an improved can end and pull tab that uses less metal than prior art can ends.

[0013] Another object of this invention is to provide a conversion press, including tools, for converting a can end shell into an improved can end having a relatively large removable panel portion in it.

[0014] The above and other objects and advantages of this invention will be more fully understood and appreciated by reference to the following description and the drawings accompanying this description.

BRIEF DESCRIPTION OF THE DRAWINGS

[0015] FIG. 1 is a top plan view of an easy-opening can end of this invention.

[0016] FIG. 2 is a cross-sectional view of the can end of FIG. 1.

[0017] FIG. 3 is an enlarged fragmentary cross-sectional view of the can end of FIGS. 1 and 2 double seamed on a can body.

[0018] FIG. 4 is an enlarged top plan view of the nose end portion of the pull tab on the can end of FIGS. 1, 2 and 3.

[0019] FIG. 5 is a fragmentary cross-sectional view of a raised bead in the can end of FIGS. 1-3 taken along line 5-5 of FIG. 1.

[0020] FIG. 6 is a fragmentary cross-sectional view through a preferred score line that can be used in a can end of this invention.

[0021] FIG. 7 is a cross-sectional view similar to FIG. 3 showing the pull tab lifted to initiate rupture of the score line adjacent the nose of the tab.

[0022] FIG. 8 is a fragmentary side elevation view showing the pull tab lifted to rupture the score line adjacent the nose of the tab.

[0023] FIG. 9 is a cross-sectional side view illustrating a press ram for converting a can end shell into an easy-opening can end in accordance with this invention.

DESCRIPTION OF PREFERRED EMBODIMENTS OF THE INVENTION

[0024] Referring to FIGS. 1, 2 and 3, a preferred embodiment of a can end 10 thereon of this invention is shown that has a pull tab 12 attached to a removable panel portion 14 by an integral rivet 16. The can end 10 has a peripheral flange 18 for attachment of the can end to a can body by double seaming or the like, and a substantially vertical chuckwall 20 integrally connected to the peripheral flange. The can end 10 may or may not have a downwardly projecting annular reinforcing groove 22 at the bottom of the chuckwall 20, and has central panel portion 24, with the removable panel 14 in it. A score line 26 circumscribes the removable panel portion 14. An antifracture score or scores, not shown, may be provided adjacent the primary score line 26.

[0025] In accordance with this invention, The pull tab 12 has a handle end portion 34 and a nose end portion 36 and has a reinforcing hem or bead 38 around substantially the entire tab to prevent bending of the tab except for limited bending near the rivet 16 as is explained below. The handle end 34 of the tab 12 preferably is ring-shaped to facilitate gripping it to open the can end.

[0026] The removable panel portion 14 may preferably include a recessed panel 28 and raised buttons 30. The buttons 30 support the handle end 34 of the tab 12 above the bottom of the recessed panel 28 to make it easier for a user to get a finger under the tab to lift it. The recessed panel 28 and buttons 30 form no part of this invention. Similar recessed panels and bottom are well known in the art.

[0027] This invention preferably further includes raised beads 32 on opposite sides of the pull tab. The beads 32 preferably extend outwardly from the nose end 36 of the tab 12 and may be generally parallel to the score line 26. FIG. 5 shows a preferred crosssectional profile of the raised beads 32. These beads 32 help control bending of the removable panel 14 when the pull tab 12 is lifted to initiate rupture of the score line adjacent the nose end of the tab 12. This controlled bending forms a chord of bending in the removable panel transversely of the nose end 36 of the tab 12 as is described below.

[0028] Referring now to FIGS. 3 and 4, the pull tab 12 has a recessed panel portion 42 in its nose end 36, and the tongue 40 is defined in such recessed panel portion 42 by a C-shaped slot 44 that extends around the rivet attachment on the side thereof toward the center of the removable panel portion 14. The slot 44 preferably has rounded ends 46 to reduce the risk of undesirable tearing of the metal in the pull tab 12 during opening.

[0029] In accordance with this invention the ends 46 of the slot 44 are located behind a transverse line x-x across the tab 12 through the center of the rivet attachment 16. As is best shown in FIG. 4, lines y-y through the ends 46 of the slot 44 and through the center of the rivet 16 form small angle α with the transverse line x-x through the center of the rivet 16. In a preferred embodiment, angle α is 10.92 degrees but may be other similar angles such as about 1-20 degrees.

[0030] Location of the slot 44 behind the rivet 16 in this invention makes it possible to locate the center of the rivet 16 closer to the tip of the nose end of the tab 12 and to the centerline of the score line 26 adjacent the nose end of the tab 12. For example, in one preferred embodiment the center of the rivet is about 0.205 inch from the centerline of the score 26. Location of the rivet 16 closer to the score line 26 is believed to facilitate initiation of rupture of the score line by reducing the required pop force.

[0031] FIG. 6 shows a cross section through a preferred embodiment of a score line 26 that may be used with this invention. The score 26 has a sharp V-shaped indentation 42 in the top face of the metal of the can end and a rounded indentation 50 in the bottom surface of the can end. Methods and tools for forming such scores are well known in the art. A variety of other score line types can be used with this invention.

[0032] FIG. 7 is an enlarged cross-sectional showing of the can end 10 after the tab 12 has been lifted to initiate rupture of the score line 26 adjacent the nose end 36 of the tab. FIG. 8 is a side elevation of the can end 10 with the tab 12 in the same position as in FIG. 7. As seen in these figures, lifting of the handle end 38 of the tab 12 has ruptured or severed a short arc (about 40-45 degrees) of the score line 26 adjacent the nose of the tab and bent the removable panel portion 14 along chordal line 52 (FIG. 7). The beads 32 in the removable panel 14 on both sides of the nose of the tab

12 help to rigidify that portion of the removable panel that is bent downwardly into the can and therefore cause rupture of the score line 26 to propagate outwardly from the nose of the tab 12 to the chordal line 52.

[0033] It is a feature of this invention that the C-shaped slot 44 in the pull tab 12 permits limited bending of the tab to facilitate initial lifting of the handle end 38 of the tab so the user can get a finger under it and further lift it to pop the score line adjacent the nose of the tab. FIG. 7 shows how the tongue 40 in which the rivet 16 is secured has hinged slightly out of the general plane of the tab 12. This hinging of the tongue is enabled by the slot 44 around the rear of the rivet attachment. This hinging also helps establish the fulcrum of the tab 12 and the removable panel 14 along a fulcrum line extending transversely of the tab approximately through the ends of the C-shaped slot 44.

[0034] From the position of the tab 12 shown in FIG. 7, the tab is preferably further lifted toward the rim of the can and then pulled substantially vertically upward to complete severance of the score line 26 around the remainder of the removable panel 14. Such lifting and pulling are common in the art. This invention is primarily aimed at reducing failure of opening of easy-opening can ends by minimizing tab tongue tears and side pulls. For example, the pull tab 12 on a can end 10 of this invention may be lifted non-symmetrically on one side more than the other without undue difficulty or failure. The mechanics of this invention also make it feasible to reduce the metal gauge in the pull tab 12 and thereby reduce costs.

[0035] The manufacturer of a can end shell into an easy-open can end takes place in a conversion press, a portion of which is shown in FIG. 9. The Minster Machine Company of Minster, Ohio manufactures and sells an industrial press suitable for configuration as a can end conversion press. The conversion press 60 generally includes a stationary press bed 62 including a generally planar horizontal upper surface 64. The upper surface supports a tooling base 66 which has a planar bottom surface 68 and a planar upper surface 70. Positioned upon the upper surface of tooling base is a lower tooling member 72 (shown in phantom) which may take a variety of shapes depending upon the tooling operation to be performed on the can end shell 74. However, each lower tooling member 72 has a planar bottom surface 76 which mates with the upper surface 150 of the tooling base 146 to provide secure support for the lower tooling member 72.

[0036] A vertically displaceable press ram 78 overlies press bed and includes a generally planar horizontal lower surface 80. This surface 80 of the press ram 78 supports a tool support mean 82 which may take a plurality of shapes depending upon the type selected for a particular tooling operation. In general, however, the tooling support means or base 82 includes an upper planar surface 84 which provides solid mating contact with the surface 80 of the press ram 78 so that the tooling support means 82 is securely fastened to the press ram. The tool support means 82 securely supports an upper tooling member (shown in phantom) 86 having an upper planar surface 88 that is in mating contact with the lower planar surface 90 of the tool support means 82. The upper tooling member 86 can be one of many shapes and sizes depending upon the particular tooling operation to be performed. Typically, a centering ring 92 locates the can end shell 74 in each tooling station. The various types of tooling

operations to be performed in succession include: bubble forming in the open can lid, forming the bubble into a button; scoring an opening; paneling the can end in an area surrounding the scored opening; staking the pull tab to the can end; and stamping incise lettering upon the can end for messages such as "lift up, pull back" or "dispose of properly." U.S. Pat. No. 4,610,156 which sets forth a detailed description of the various tooling stations of a conversion press. The contents of this patent are incorporated by reference as fully set forth herein. The can end conversion process may require from six to eight stations in which differently configured tooling effects each successive stage in the conversion of a can end shell into an easy-opening can end.

[0037] It is therefore seen that this invention provides an improved easy-opening pull tab and can end having a relatively large removable panel which is easier to open than prior art ends. The invention facilitates metal savings in the pull tab.

[0038] Having described and illustrated the features and principles of the invention and preferred embodiments for achieving such objectives and advantages, it will be apparent to those skilled in the art that numerous modifications can be made to the preferred embodiments without departing from the invention or the scope of the claims appended hereto. For example, can ends of this invention may include moustache scores in the removable panel portions. Such moustache scores are well known in the art.

What is claimed is:

1. In an easy-opening can end having a rupturable score line defining a relatively large tear panel and a pull tab attached to the tear panel, said pull tab having a handle end portion and a nose end portion attached to the tear panel by a rivet in said nose end portion of the tab,

the improvement wherein said pull tab has a bending fulcrum between said handle end portion and said nose end portion behind the rivet attachment to the tear panel.

2. An easy-opening can end as set forth in claim 1 in which said rivet has a one-eighth inch diameter.

3. An easy-opening can end as set forth in claim 1 in which said pull tab has a C-shaped slot in it around one side of said rivet.

4. An easy-opening-can end as set forth in claim 3 in which said C-shaped slot has opposite ends defining said fulcrum.

5. An easy-opening can end as set forth in claim 1 in which said pull tab has a finger opening in said handle end portion.

6. An easy-opening can end as set forth in claim 5 in which said handle end portion of the tab has an upwardly inclined distal end to facilitate gripping to open the can end.

7. An easy-opening can end as set forth in claim 1 in which said pull tab has a curled hem around its outer edge.

8. An easy-opening can end as set forth in claim 1 in which said tear panel has a recessed portion in it under the handle end of the tab and raised beads that support the handle end above the top surface of such recessed portion.

9. An easy-opening can end as set forth in claim 1 in which the center of said rivet is in a range of about 0.175 to 0.225 inches from the outer end of the nose end of said tab.

10. An easy-opening can end as set forth in claim 4 in which the lines through the center of the rivet and the end of said C-shaped slot form an angle of about 8-12 degrees with a transverse line across the nose of the tab through the center of the rivet.

11. An easy-opening can end as set forth in claim 1 in which the center of said rivet is about 0.205 inch from the centerline of said score line.

12. An easy-opening can end as set forth in claim 1 in which said tear panel has raised beads on opposite sides of the nose end of said pull tab extending generally outwardly from said tab.

13. A pull tab for an easy-opening can end having a relatively large tear panel in it, said pull tab having a handle portion and a nose portion with a reinforcing hem around the periphery of the tab and having a rivet hole in the nose end of the tab for receiving a rivet attaching the tab to said tear panel, said tab further having a C-shaped lance in its nose end defining a tongue in which said rivet hole is located, said C-shaped lance extending partially around the rivet on the handle end of the tab and said lance having ends disposed on opposite sides of the rivet hole behind the centerline of said rivet hole.

14. A pull tab as set forth in claim 13 in which said rivet hole has a diameter of about one-eighth inch.

15. A pull tab as set forth in claim 13 in which the centerline of said rivet hole is about 0.205 inch from the nose end of the tab.

16. A pull tab as set forth in claim 13 in which lines through the center of said rivet hole and the ends of said C-shaped lance form an angle of about 8-12 degrees with a transverse centerline through said rivet hole.

17. A pull tab as set forth in claim 12 that is made of 0.016 inch thick hard temper aluminum alloy.

18. An easy-opening can end having a rupturable score line in it defining a relatively large tear panel and a pull tab attached to the tear panel by an integral rivet, said pull tab having a handle portion and a nose portion and having a hole in the nose portion receiving said integral rivet, and further having a C-shaped slot in said nose portion partially around said rivet hole toward the center of said can end.

19. An easy-opening end as set forth in claim 18 in which said tear panel has raised beads in it on opposite sides of the nose end of said pull tab extending outwardly from said nose end of the tab.

20. An easy-opening end as set forth in claim 18 in which the ends of said C-shaped slot are behind a transverse line through the center of said rivet hole.

21. Tooling for conversion of a can end shell into an easy-opening can end having a rupturable score line defining a relatively large tear panel and a pull tab attached to the tear panel, said pull tab having a handle end portion and a nose end portion attached to said tear panel by a rivet in said nose end portion of the tab, said pull tab having a bending fulcrum between said handle end portion and said nose end portion behind the rivet attachment to said tear panel, and said tooling including means for forming said rivet integrally in a can end shell, means for forming said rupturable score line, means for positioning said pull tab on said rivet and means for staking said rivet to secure the pull tab on the end shell.

22. Tooling as set forth in claim 21 in said pull tab has a C-shaped slot in it around one side of said rivet.

23. Tooling as set forth in claim 22 in which said C-shaped slot has opposite ends defining said fulcrum.

24. Tooling as set forth in claim 21 in which said rivet has a one-eighth inch diameter.

25. Tooling as set forth in claim 21 which includes means for forming raised beads in said tear panel on opposite sides of the nose end of said pull tab extending generally outwardly from said tab.

26. A conversion press for converting a can end shell into an easy-opening can end having a rupturable score line defining a relatively large tear panel and a pull tab attached to the tear panel, said pull tab having a handle end portion and a nose end portion attached to said tear panel by a rivet in said nose end portion, said pull tab having a bending fulcrum between said handle end portion and said nose end portion behind the rivet attachment to said tear panel, and said conversion press including means for forming said rivet integrally in a can end shell, means for forming said rupturable score line, means for positioning said pull tab on said rivet, and means for staking said rivet to secure the pull tab on the end shell.

27. A conversion press as set forth in claim 26 in which said means for forming said rivet forms a rivet having a one-eighth inch diameter.

28. A conversion press as set forth in claim 26 which attaches a pull tab having a C-shaped slot in it around the rear side of said rivet and said slot has opposite ends defining said bending fulcrum.

29. A conversion press as set forth in claim 26 which includes means for forming raised beads in said tear panel on opposite sides of said nose end of the pull tab extending generally outwardly from said pull tab.

* * * * *