



US005926745A

# United States Patent [19] Threadgill et al.

[11] Patent Number: **5,926,745**  
[45] Date of Patent: **Jul. 20, 1999**

- [54] NETWORK OPERATIONS CENTER FOR MOBILE EARTH TERMINAL SATELLITE COMMUNICATIONS SYSTEM
- [75] Inventors: **Michael E. Threadgill; Charles H. Biegel**, both of Reston, Va.
- [73] Assignee: **AMSC Subsidiary Corporation**, Reston, Va.
- [21] Appl. No.: **08/700,943**
- [22] Filed: **Aug. 21, 1996**

### Related U.S. Application Data

- [60] Provisional application No. 60/007,748, Nov. 30, 1995.
- [51] Int. Cl.<sup>6</sup> ..... **H04Q 7/20**
- [52] U.S. Cl. .... **455/12.1; 455/427; 455/428**
- [58] Field of Search ..... 455/12.1, 427, 455/428, 430, 406, 405, 410, 411, 429, 453, 13.1, 524; 380/21, 23, 25, 49; 340/825.3, 825.31, 825.34

### References Cited

#### U.S. PATENT DOCUMENTS

5,287,541	2/1994	Davis et al. ....	455/12.1
5,526,404	6/1996	Wiedeman et al. .	
5,555,444	9/1996	Diekelman et al. ....	455/12.1
5,586,165	12/1996	Wiedeman .	
5,590,395	12/1996	Diekelman .	
5,594,740	1/1997	Ladue .	
5,594,780	1/1997	Wiedeman et al. .	
5,634,190	5/1997	Wiedeman .....	455/12.1
5,708,716	1/1998	Tisdale et al. ....	455/54.2
5,710,805	1/1998	Armbruster et al. ....	455/435
5,713,075	1/1998	Threadgill et al. ....	455/12.1
5,717,830	2/1998	Sigler et al. ....	455/426
5,732,359	3/1998	Baranowsky et al. ....	455/437
5,748,742	5/1998	Tisdale et al. ....	455/410

### OTHER PUBLICATIONS

- "Feederlink Earth Station to Provide Mobile Satellite Services in North America", Robert H. McCauley, et al., American Institute of Aeronautics and Astronautics, Jan./Feb. 1994, pp. 1-9.
- "Radio Transmission in the American Mobile Satellite System", Charles Kittiver, American Institute of Aeronautics and Astronautics, Inc., pp. 280-294.
- "Summary of the AMSC Mobile Telephone System", Gary A. Johanson, et al., American Institute of Aeronautics and Astronautics, Inc., pp. 1-11.
- "Implementation of a System to Provide Mobile Satellite Services in North America", Gary A. Johanson, et al., presented at International Mobile Satellite Conference '93, Jun. 16-18, 1993.
- "The American Mobile Satellite Corporation Space Segment", David J. Whalen, et al., pp. 394-404.

*Primary Examiner*—Dwayne D. Bost  
*Assistant Examiner*—Jean A. Gelin  
*Attorney, Agent, or Firm*—Irah H. Donner; Pepper Hamilton LLP

### [57] ABSTRACT

A mobile satellite system includes a satellite communication switching office and network system having a satellite antenna for receiving and transmitting a satellite message via a satellite to and from a mobile earth station. A central controller receives and transmits the satellite message from the mobile earth station to and from the satellite communication switching office. The mobile communication system includes a user interface system through which a user has access to services supported by the mobile satellite system and an antenna system which provides an interface between the mobile communication system and the mobile satellite system. The mobile satellite system comprises a network operations center (NOC) that manages and controls the resources of the satellite network system and conducts the administrative functions associated with the management of the satellite network system. The NOC communicates with the various internal and external entities via a control network.

**13 Claims, 33 Drawing Sheets**

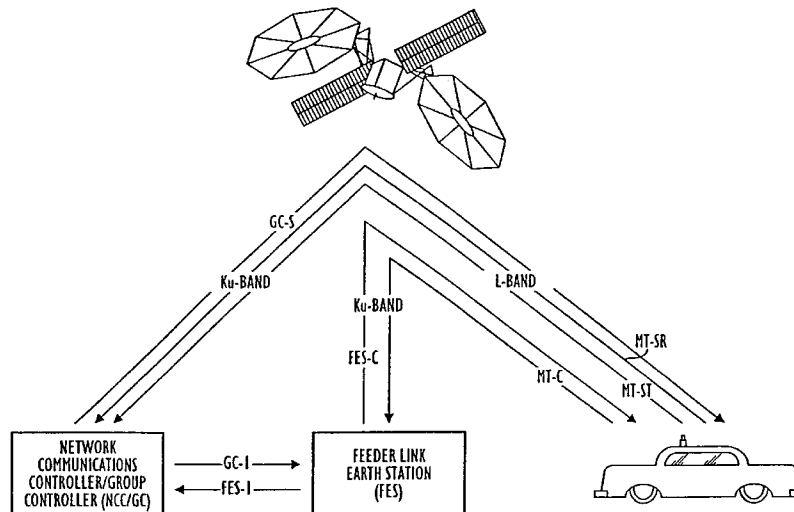

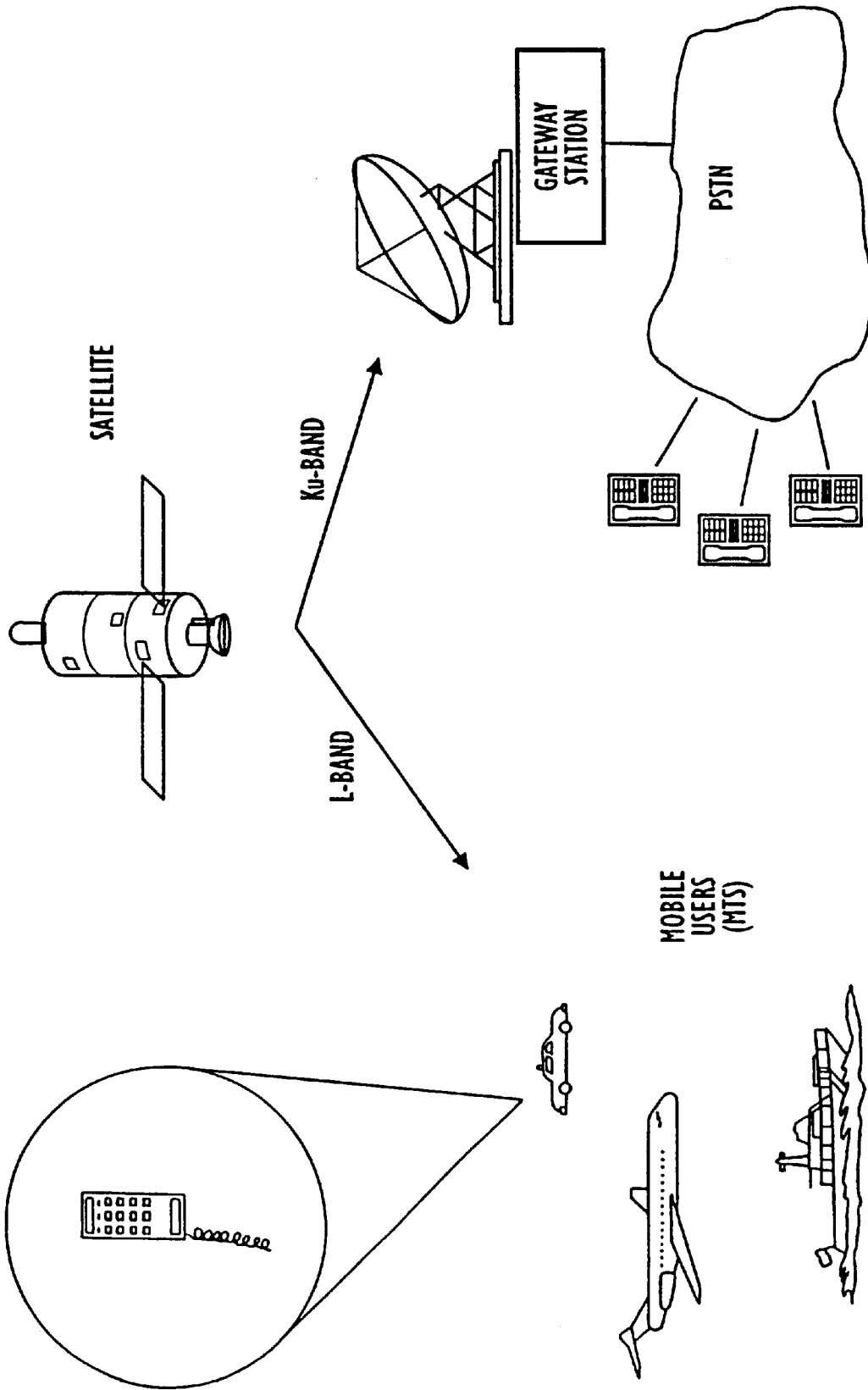

Fig. 1

PARAMETER	REQUIREMENT
L-BAND AEIRP	56.6 dBW AT NOISE POWER RATIO OF 18 dB
Ku-BAND AEIRP	36.7 dBW
L-BAND RECEIVE G/T	+2.7 dB/K
Ku-BAND RECEIVE G/T	-3.6 dB/K
L-BAND FREQUENCIES	1530 TO 1559 MHz (TRANSMIT) 1631.5 TO 1660.5 MHz (RECEIVE)
Ku-BAND FREQUENCIES	10,750 - 10,950 MHz (CENTRAL SATELLITE TRANSMIT) 13,000 - 13,150 MHz & 13,200 - 13,250 MHz (CENTRAL SATELLITE RECEIVE) 11,700 - 11,900 MHz (WING SATELLITE TRANSMIT) 14,000 - 14,200 MHz (WING SATELLITE RECEIVE)

Fig. 2

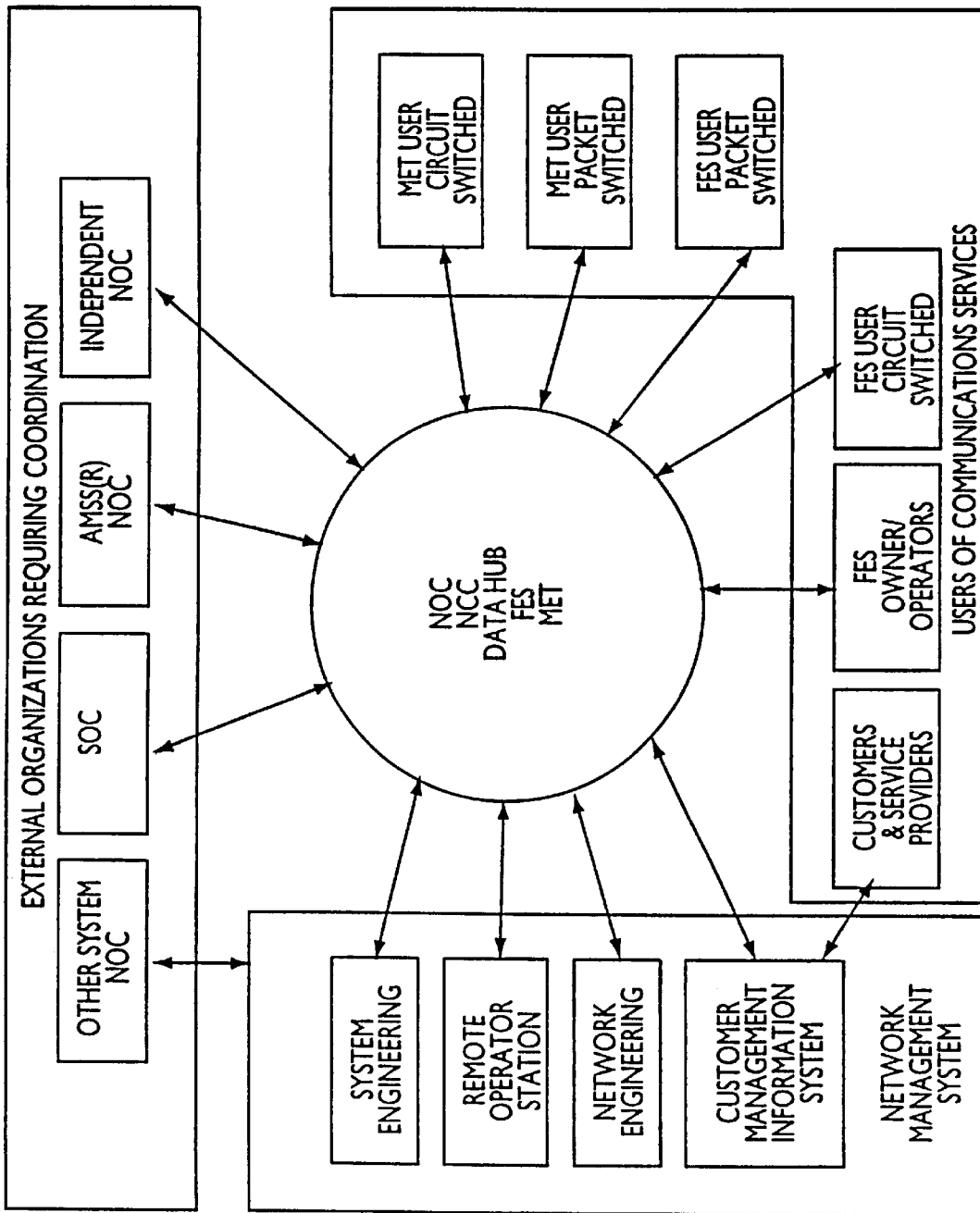

Fig. 3

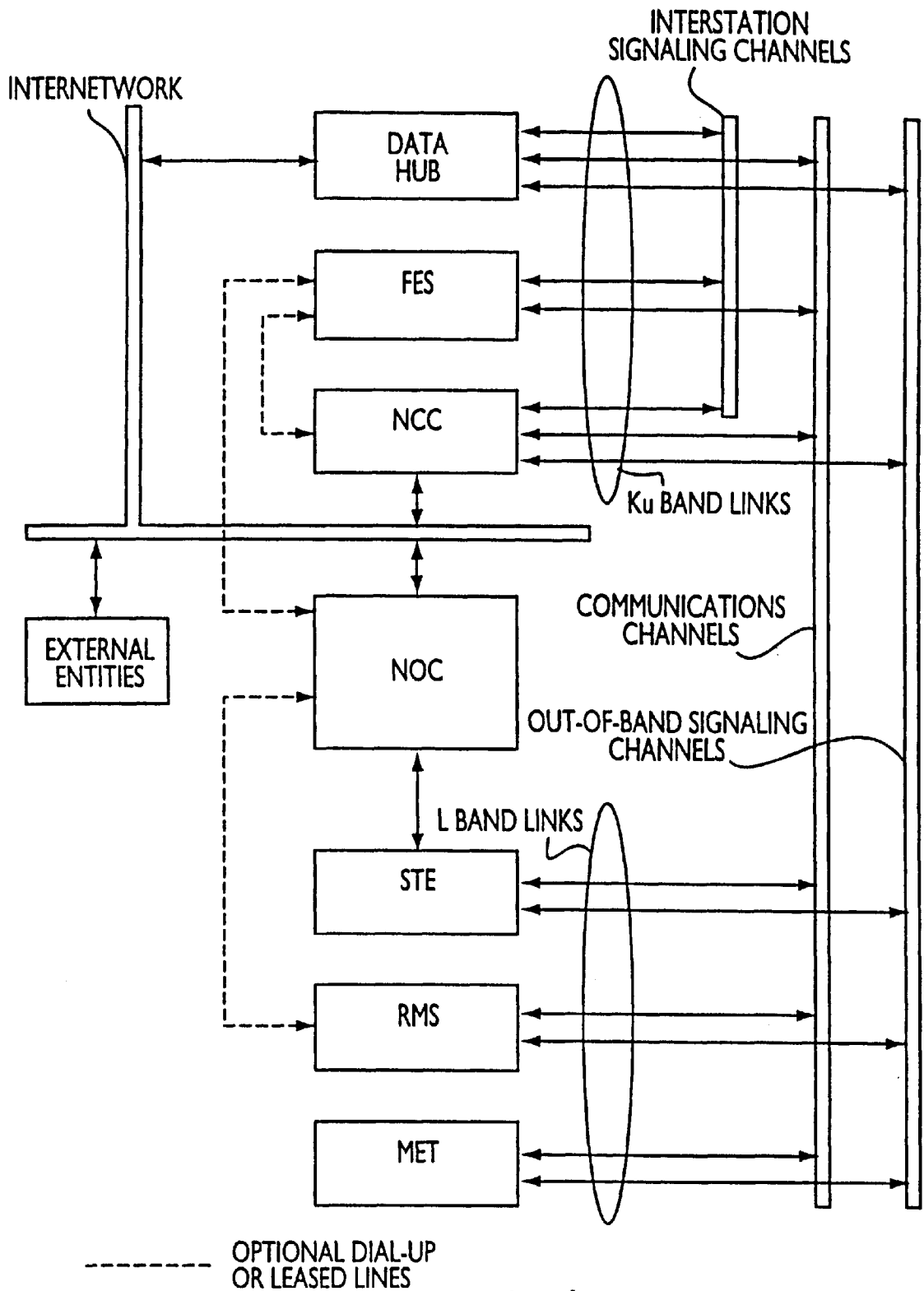

Fig. 4

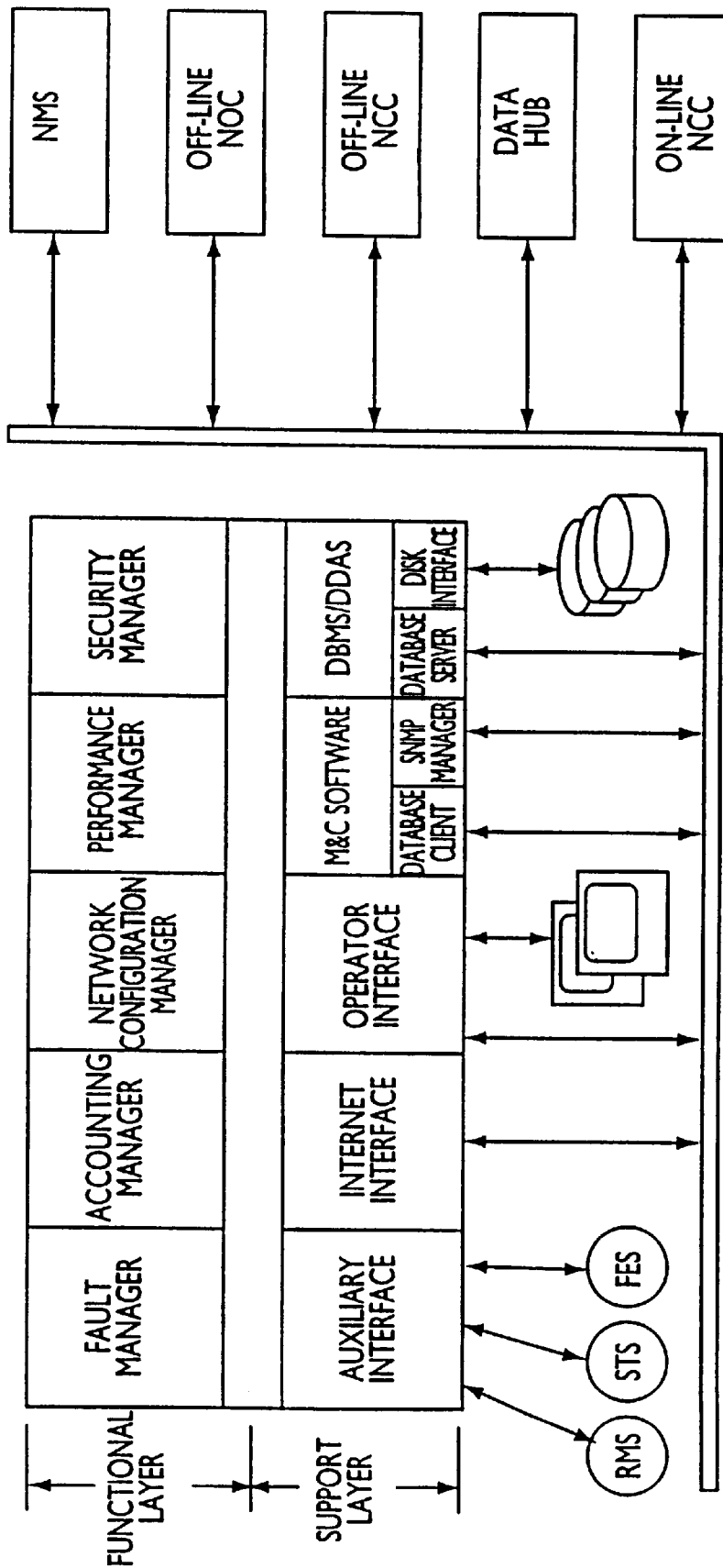

Fig. 5

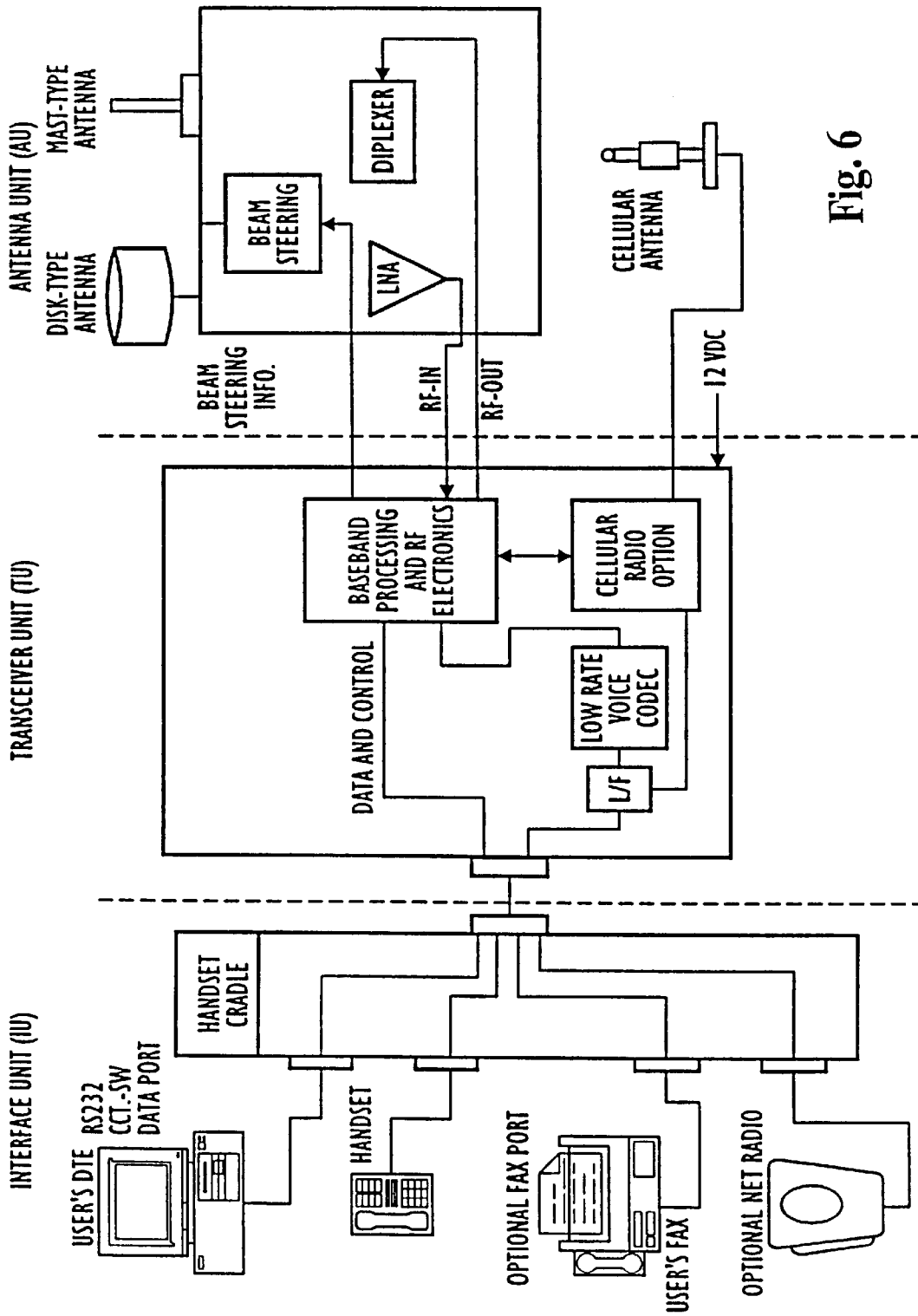

Fig. 6

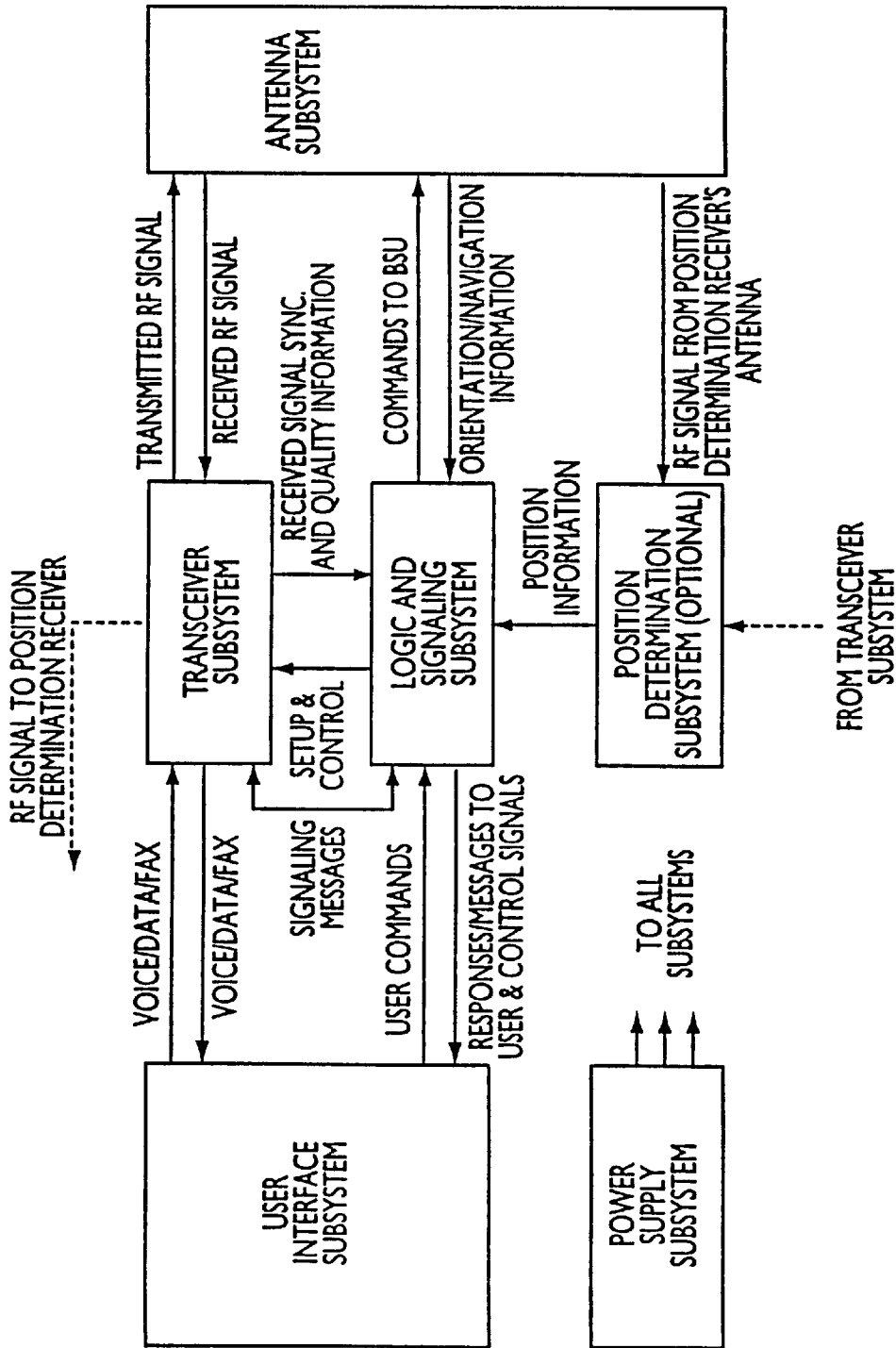

Fig. 7



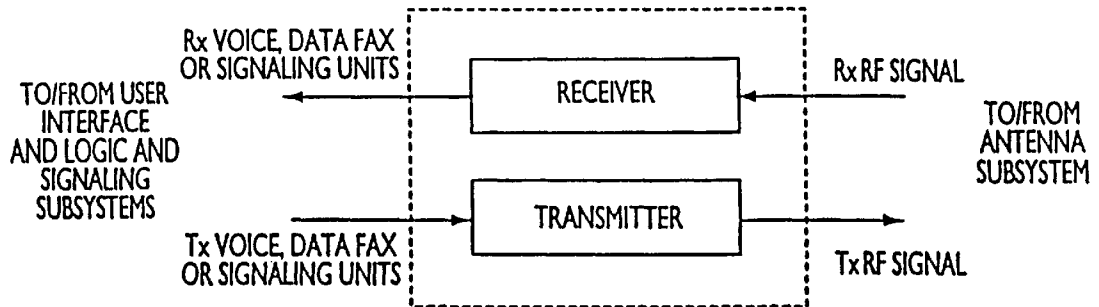

Fig. 8a

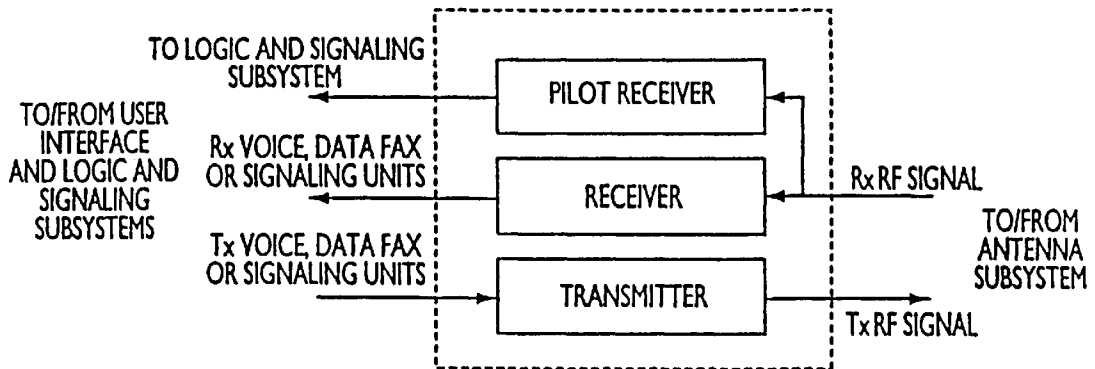

Fig. 8b

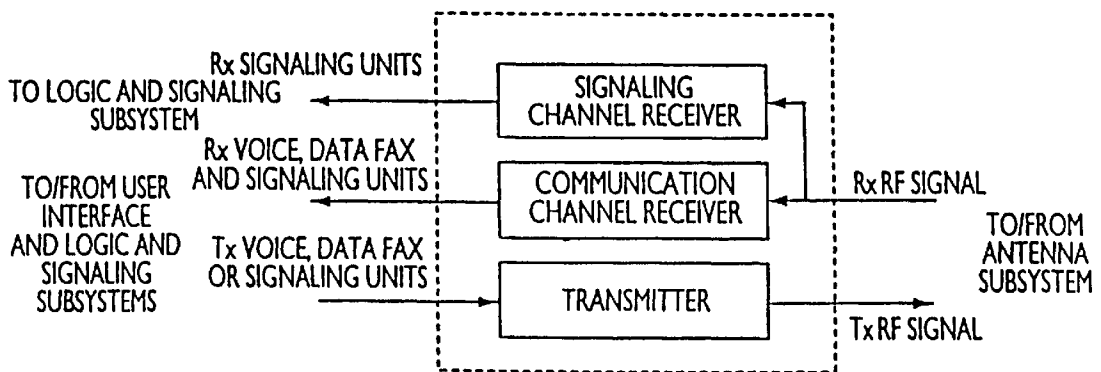

Fig. 8c

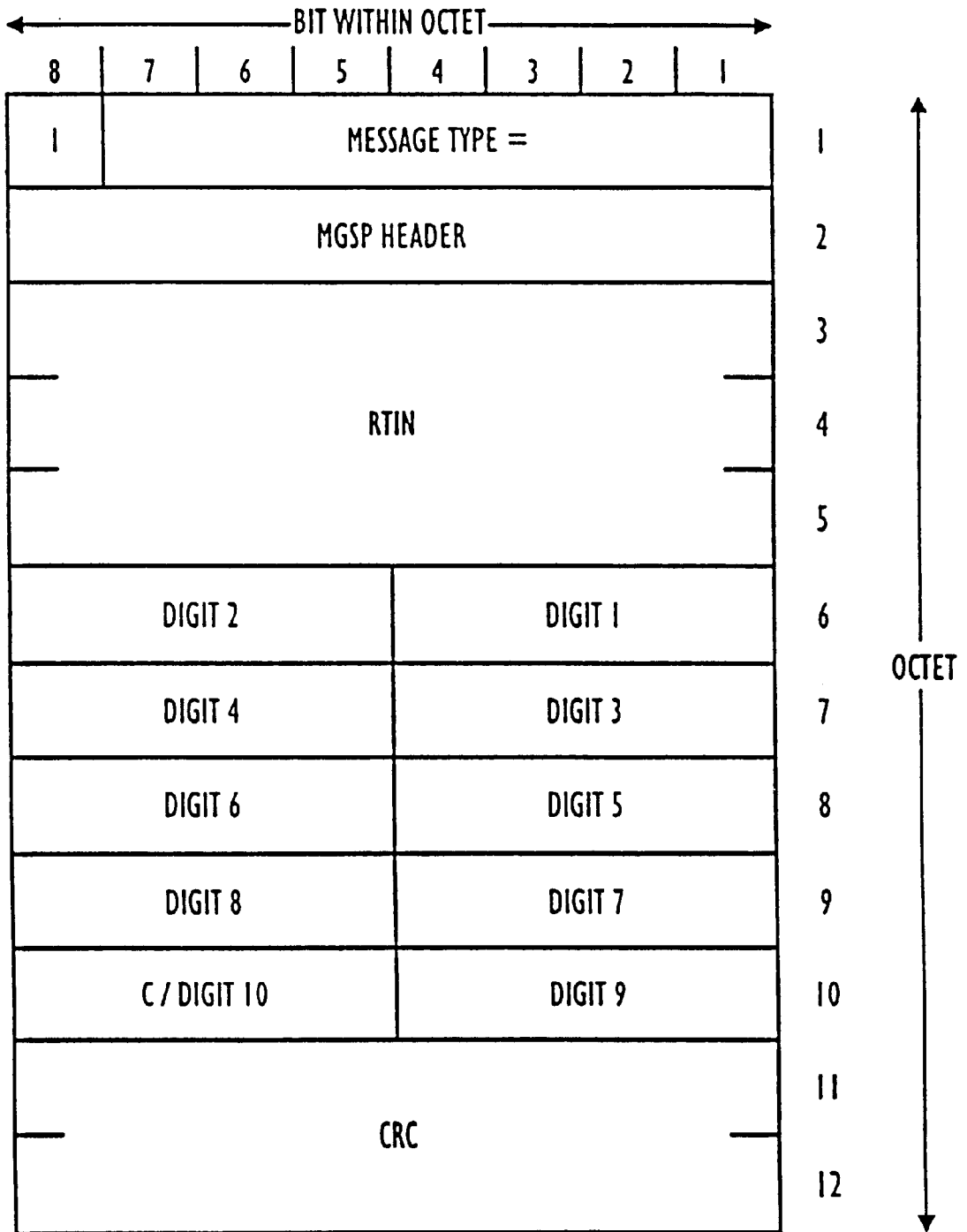

Fig. 9a

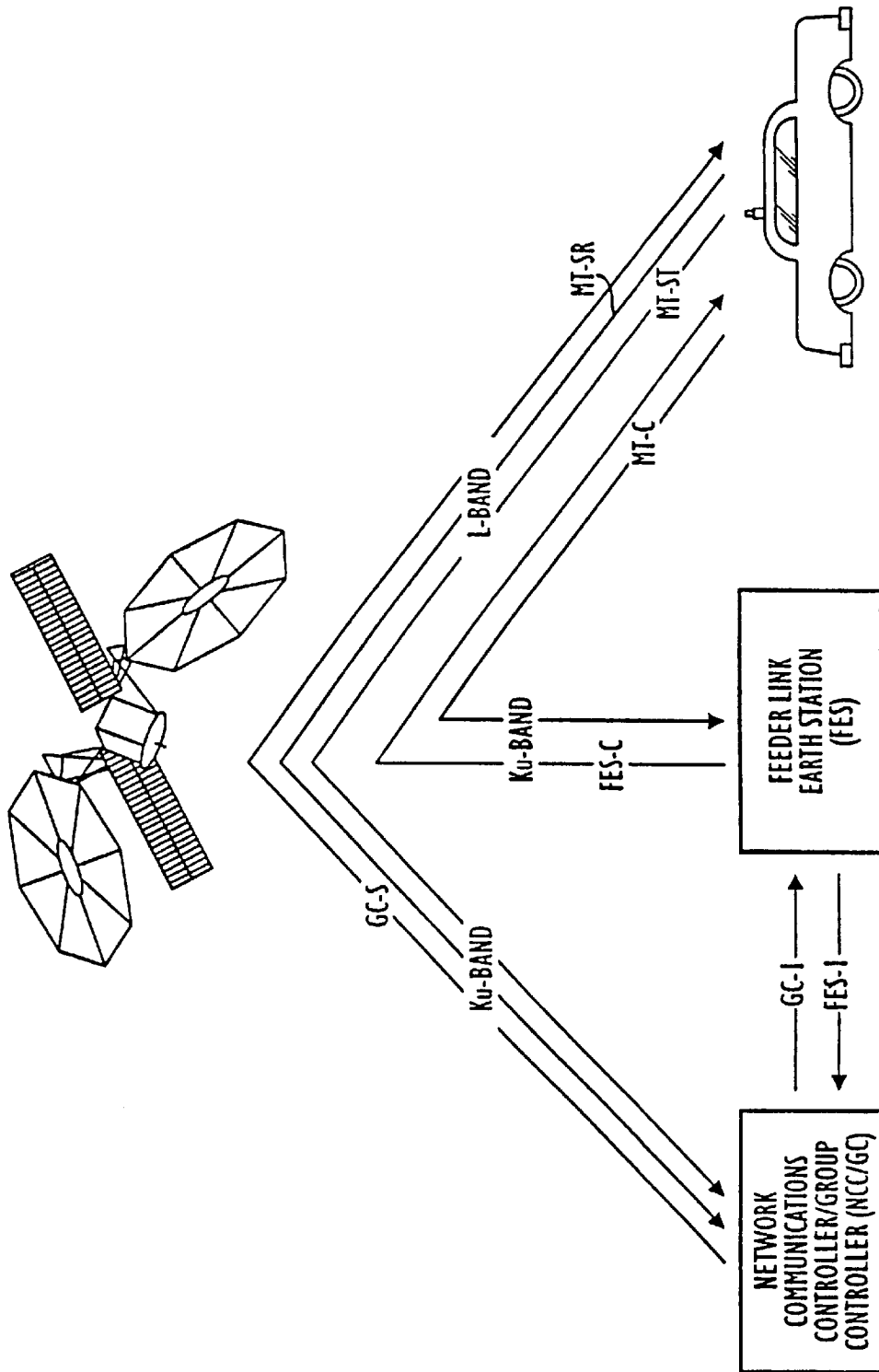

Fig. 9b



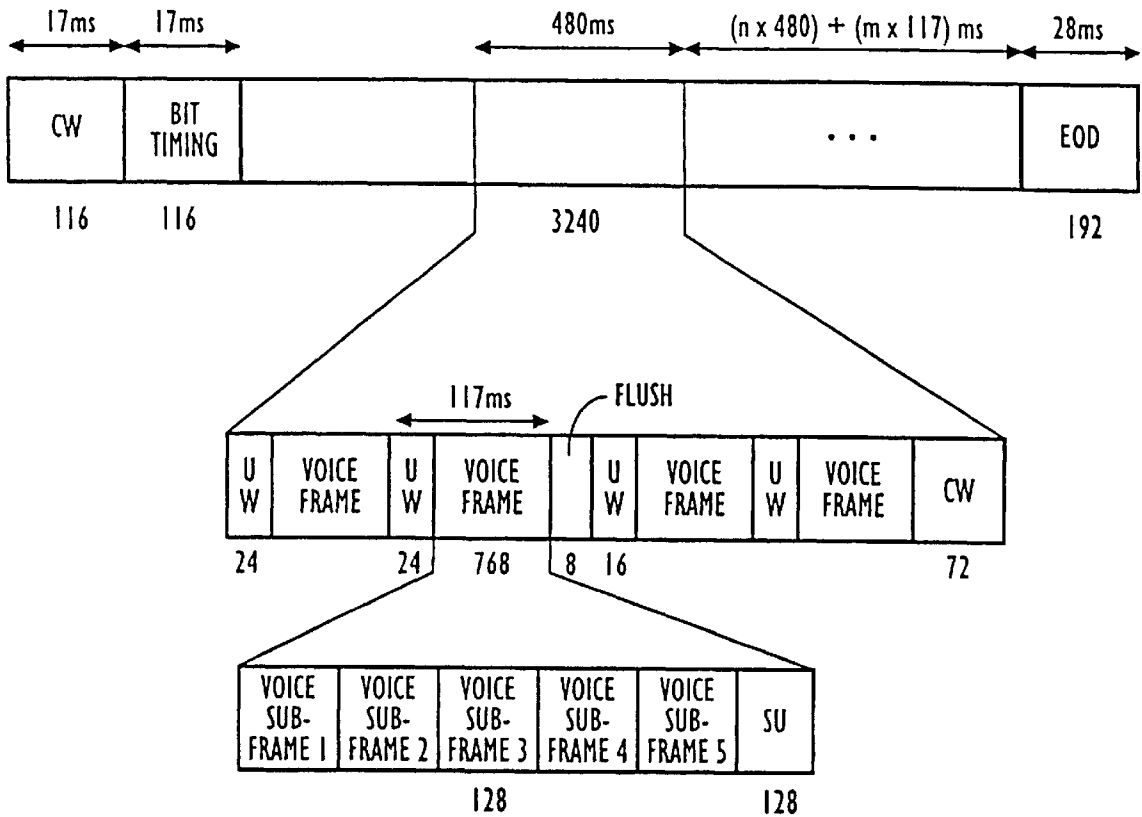

Fig. 11

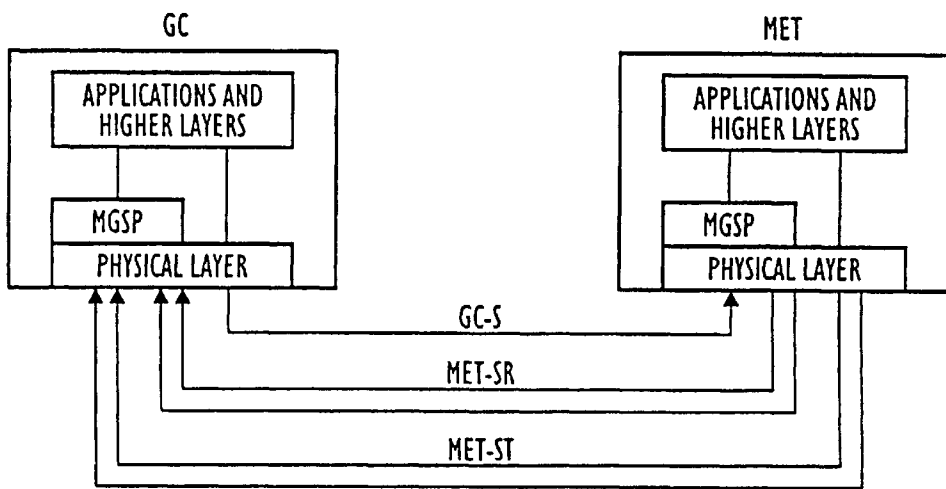

Fig. 12

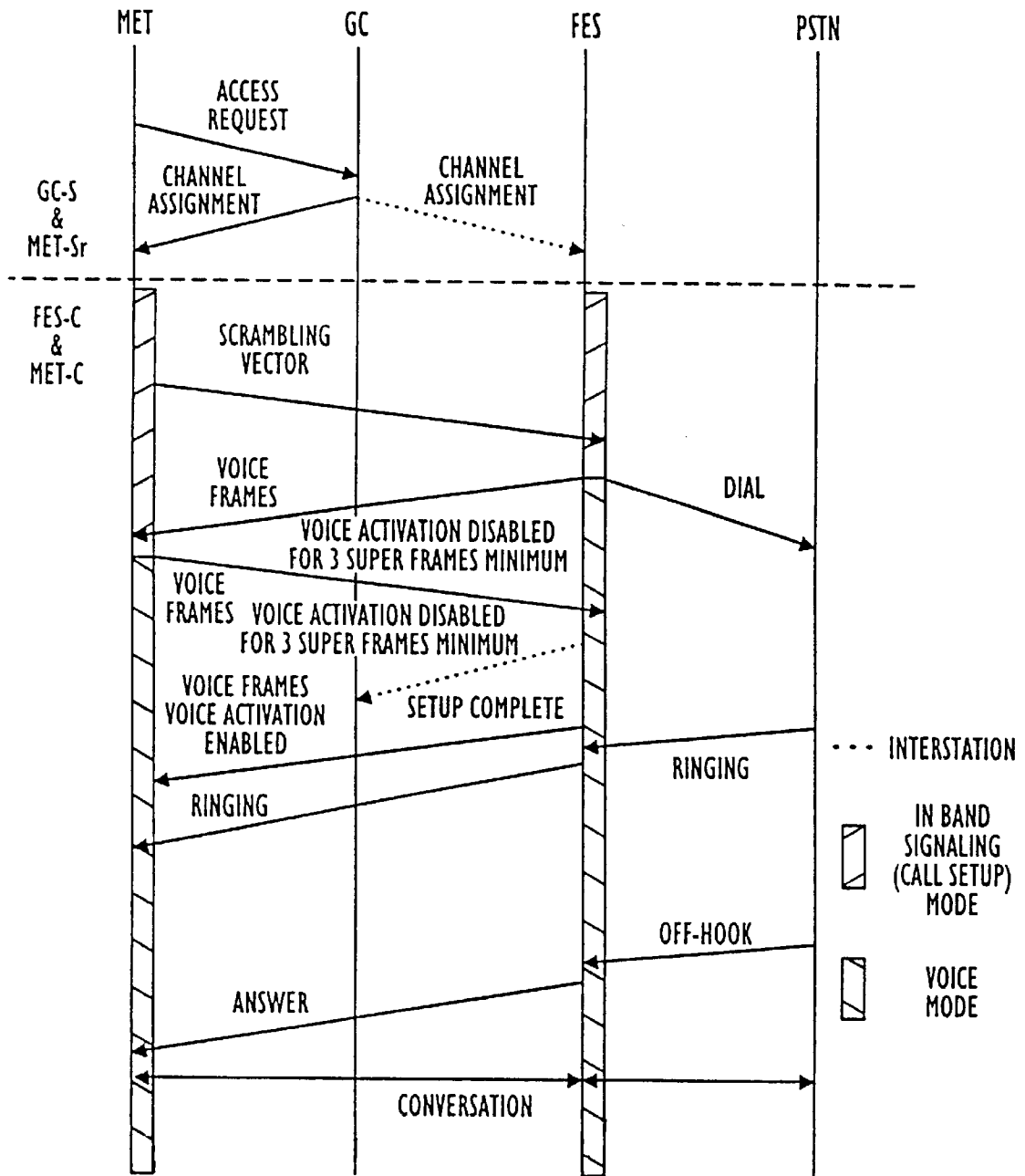

Fig. 13

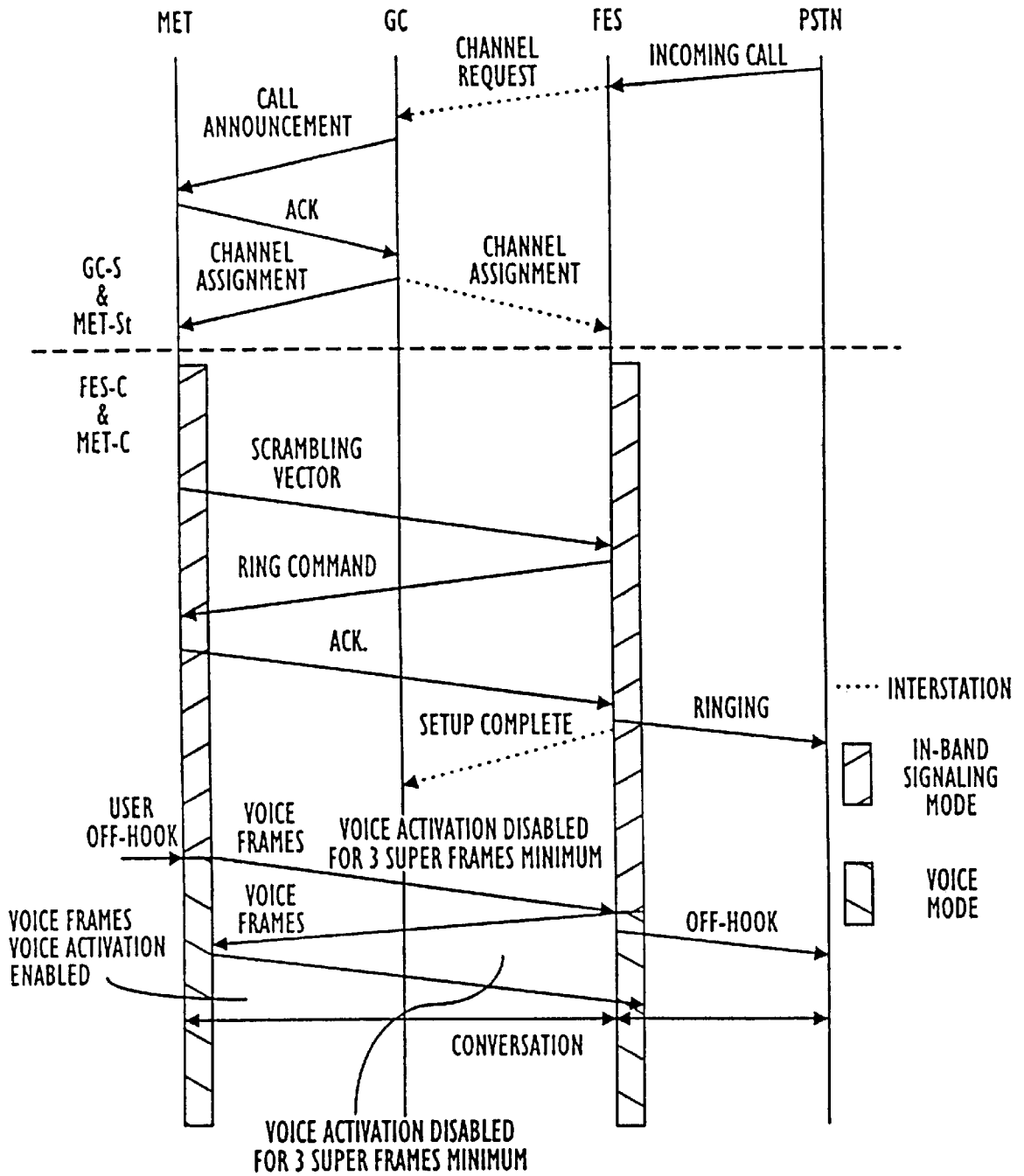

Fig. 14

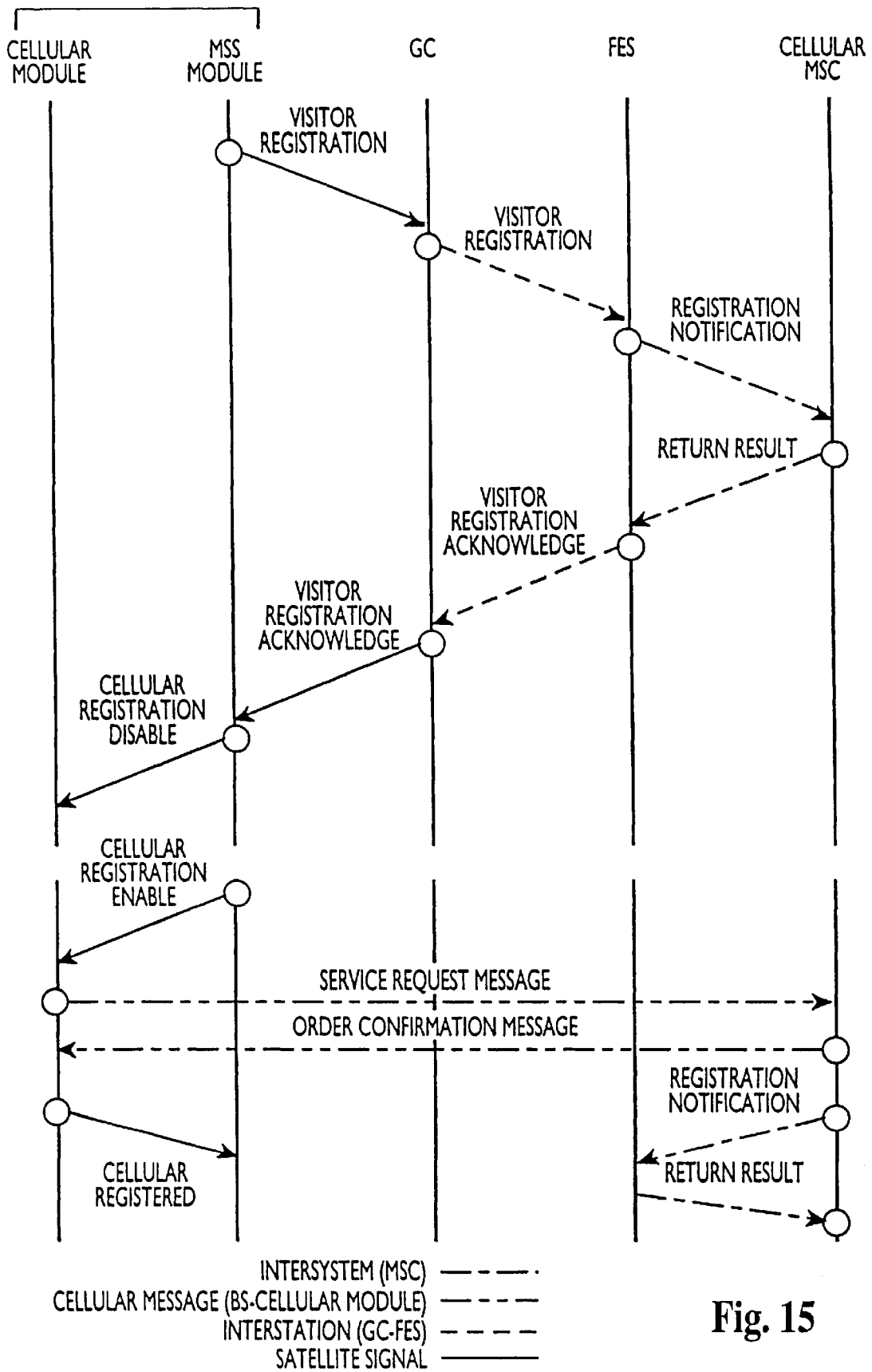

Fig. 15



MODES/FUNCTIONS		
MODE	REGISTRATION	OPERATION
SATELLITE ONLY	POWER ON REGISTRATION IN MSS ONLY, IF AVAILABLE. SYSTEM MAY NOT RE-REGISTER IS PRIOR REGISTRATION WAS IN MSS.	MET USES MSS ONLY. IF SATELLITE COVERAGE IS UNAVAILABLE, SERVICE IS DISALLOWED. NO REQUIREMENT FOR HANDOFF.
AUTOMATIC ROAMING, SATELLITE PRIORITY	POWER ON REGISTRATION IN MSS, UNLESS UNAVAILABLE, IN WHICH CASE MET REGISTERS IN CMC SYSTEM. MOBILE WILL RETURN REGISTRATION TO MSS WHENEVER POSSIBLE.	MET USES MSS IF AVAILABLE. CELLULAR COMMUNICATION IS USED AS LAST RESORT. LIVE CALL HANDOFF FROM SERVING CMC IS TO ADJACENT CMC IF POSSIBLE. OTHERWISE TO MSS. HANDOFF FROM MSS TO CELLULAR IS NOT SUPPORTED.
AUTOMATIC ROAMING, CELLULAR PRIORITY	POWER ON REGISTRATION IN CMC SYSTEM, EITHER HOMED OR AS VISITOR. IF CELLULAR COVERAGE IS UNAVAILABLE, MET WILL REGISTER IN MSS. MET WILL RETURN REGISTRATION TO CMC WHENEVER POSSIBLE.	MET USES CELLULAR CARRIER IF AVAILABLE. SATELLITE COMMUNICATION IS USED AS LAST RESORT. LIVE CALL HANDOFF FROM SERVING CMC IS TO ADJACENT CMC IF POSSIBLE, OTHERWISE TO MSS. HANDOFF FROM MSS TO CELLULAR IS NOT SUPPORTED
AUTOMATIC ROAMING, CELLULAR PRIORITY, HOME CMC ONLY	POWER ON REGISTRATION IN CMC SYSTEM, IF AVAILABLE. IF HOME CELLULAR COVERAGE IS UNAVAILABLE, MET WILL REGISTER AS A ROAMER IN MSS. MET WILL RETURN REGISTRATION TO HOME CMC WHENEVER POSSIBLE.	MET USES HOME CELLULAR CARRIER IF AVAILABLE, AND ROAMS ONLY TO MSS. LIVE CALL HANDOFF FROM SERVING CMC IS TO ADJACENT CMC IF POSSIBLE, OTHERWISE TO MSS. HANDOFF FROM MSS TO CELLULAR IS NOT SUPPORTED.
CELLULAR ONLY	POWER ON REGISTRATION IN HOME CMC IF AVAILABLE, OR AS ROAMER IN VISITED CMC. REGISTRATION FOLLOWS NORMAL CELLULAR PROCEDURES. REGISTRATION AS ROAMER IN MSS IS DISALLOWED.	MET USES HOME CELLULAR CARRIER IF AVAILABLE, AND ROAMS ONLY TO OTHER CMCs. LIVE CALL HANDOFF FROM SERVING CMC IS TO ADJACENT CMC IF POSSIBLE. HANDOFF TO MSS IS DISALLOWED.

Fig. 16

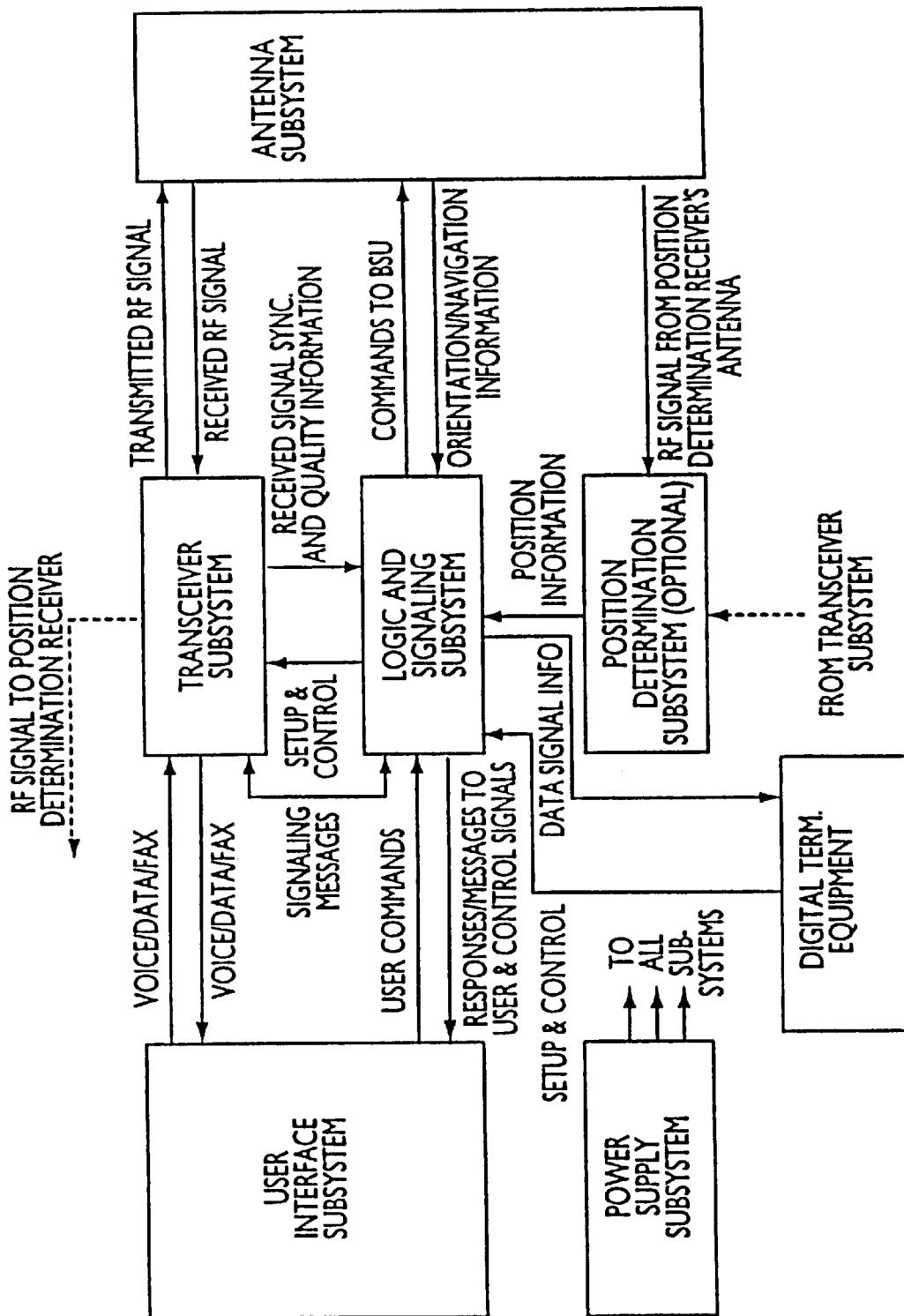
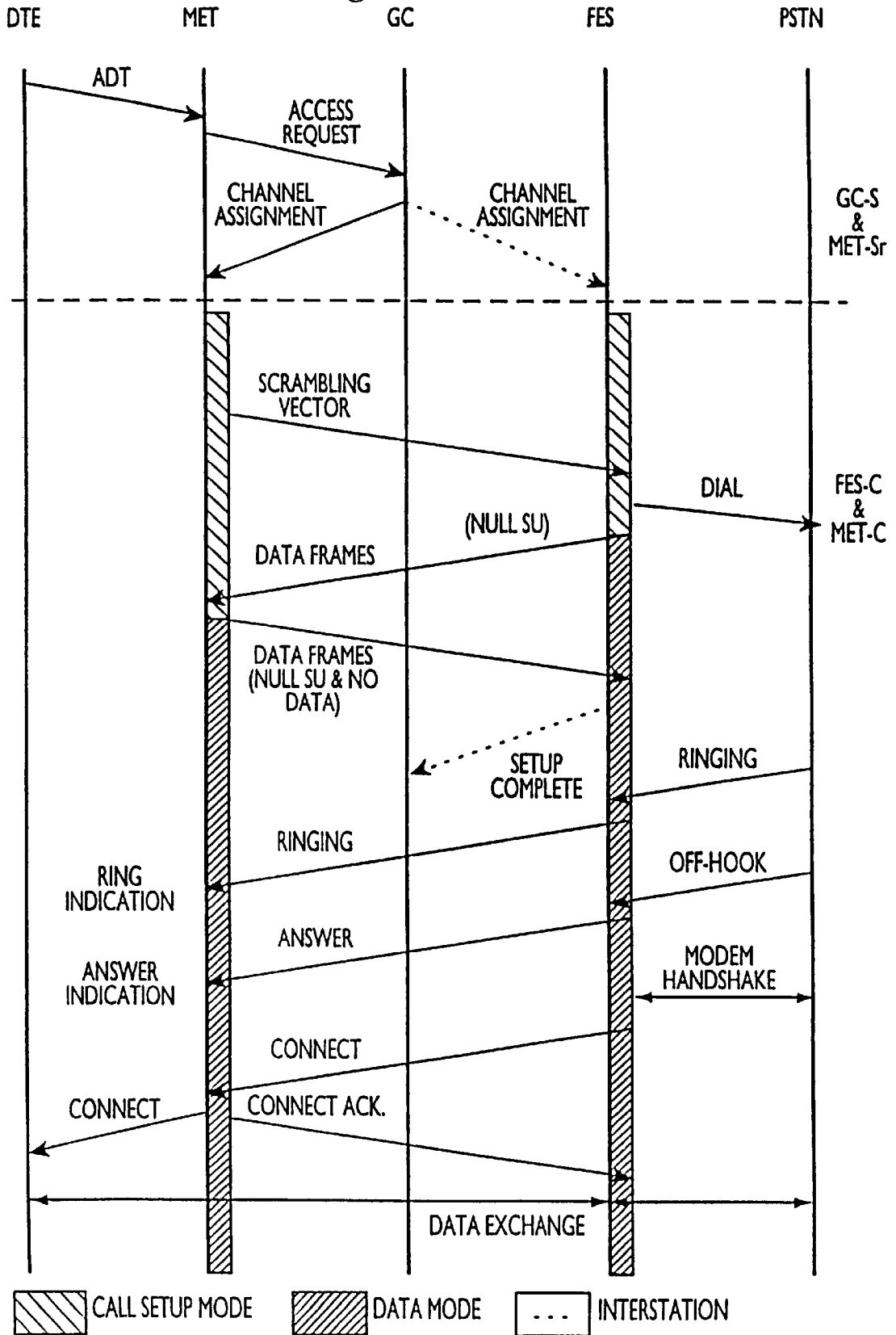

Fig. 17a

Fig. 17b



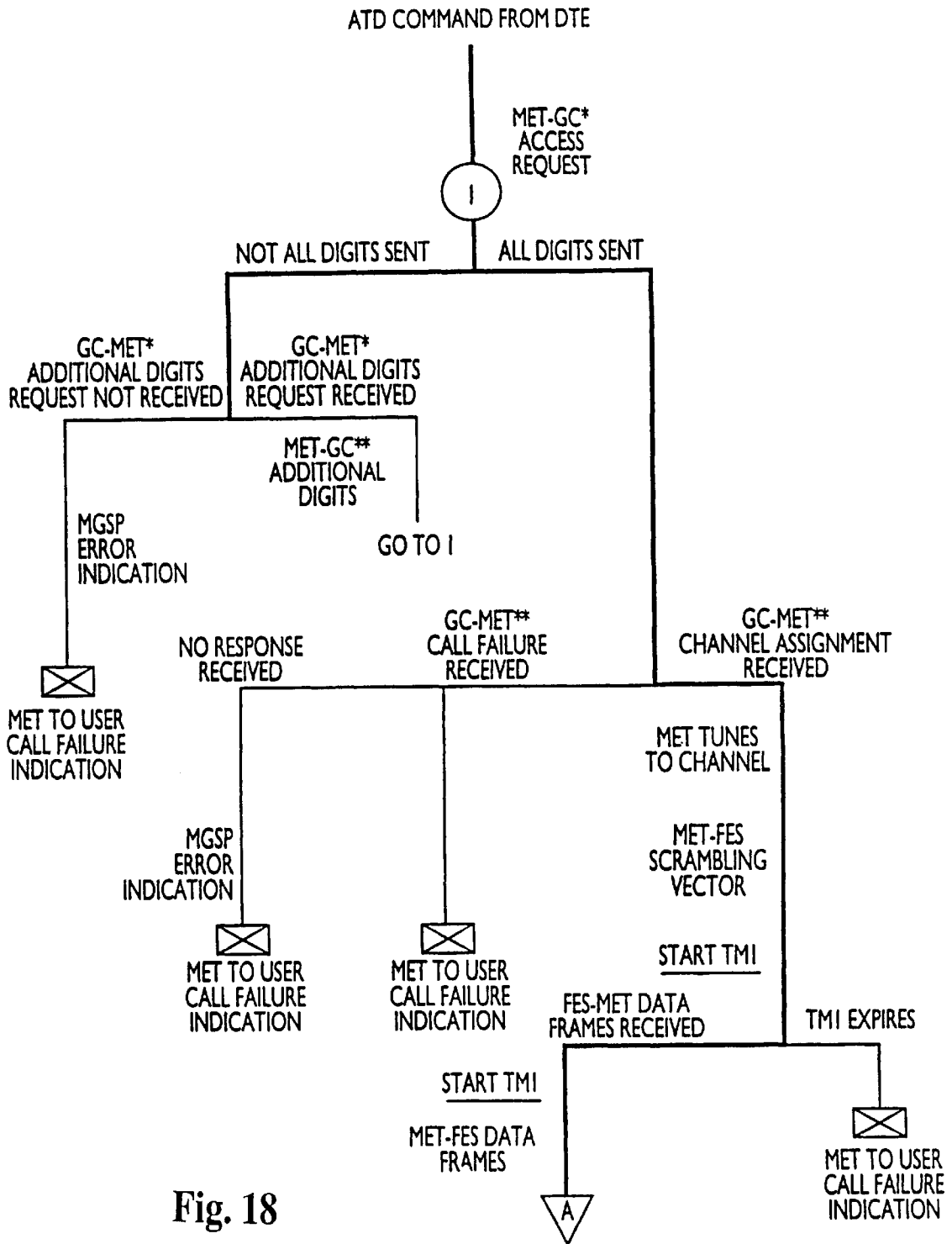

Fig. 18

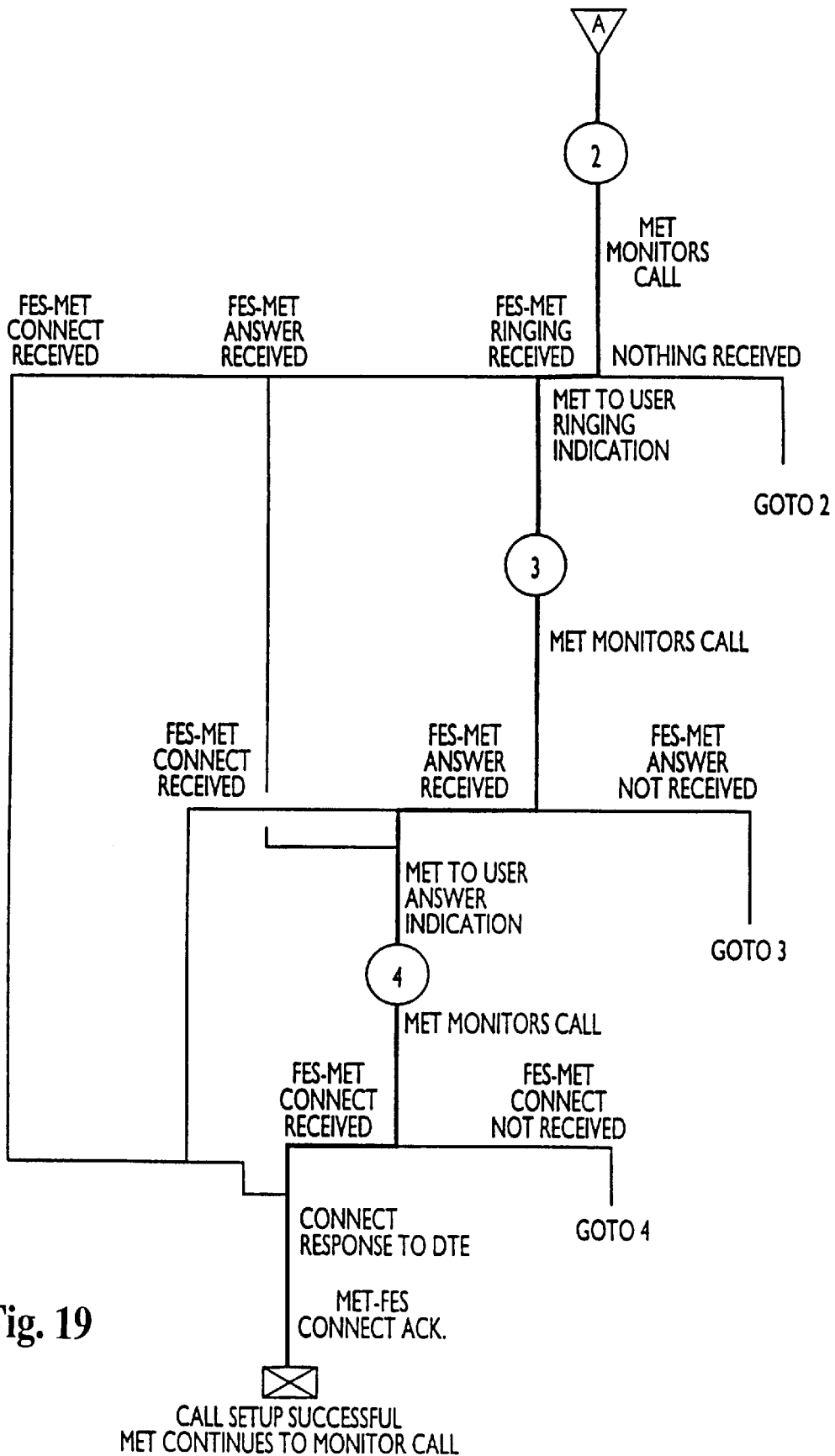

Fig. 19

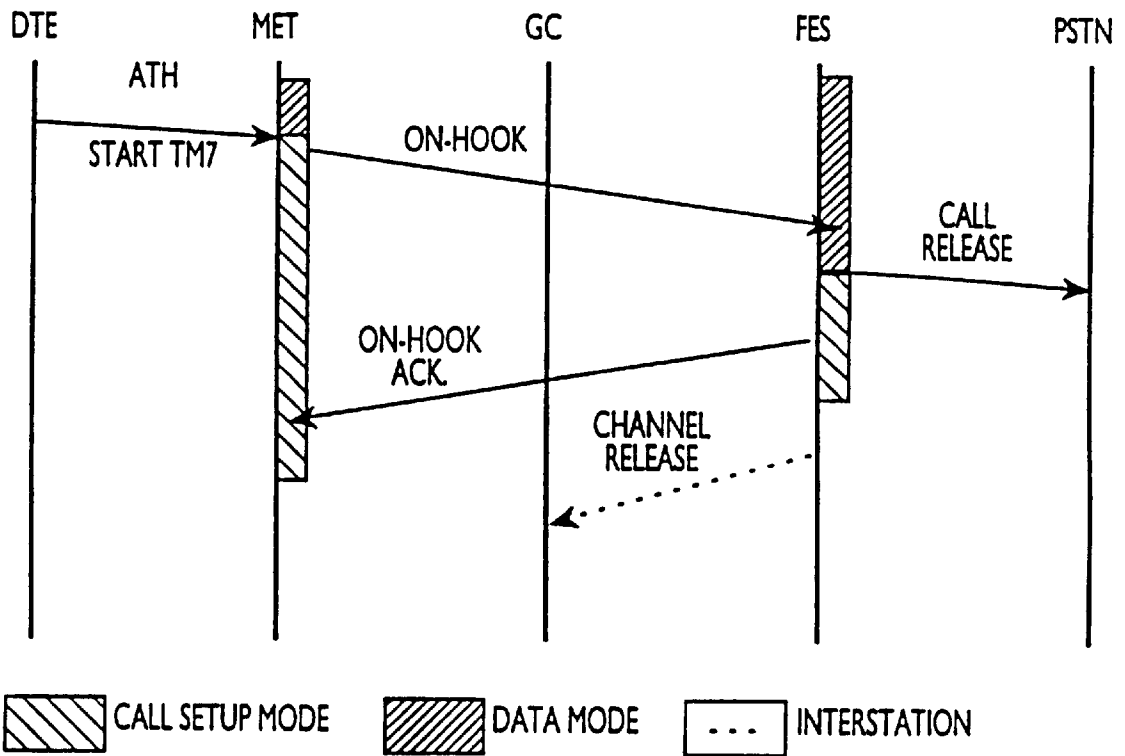

Fig. 20

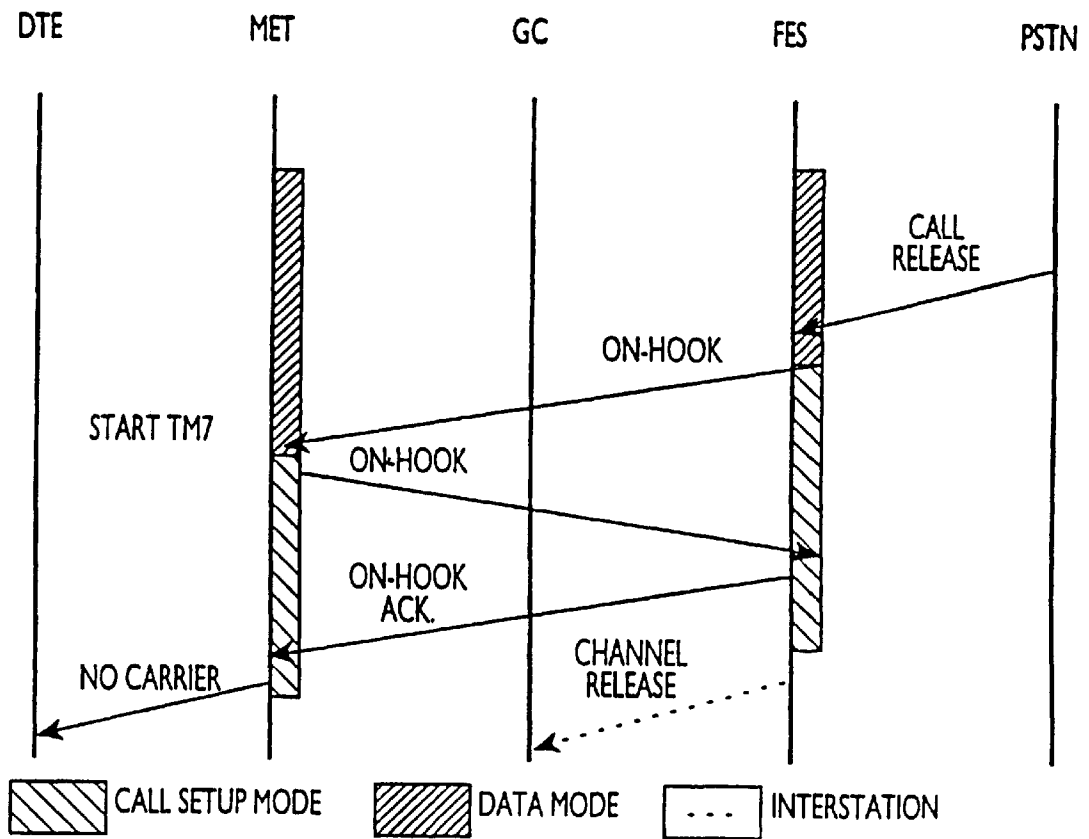

Fig. 21

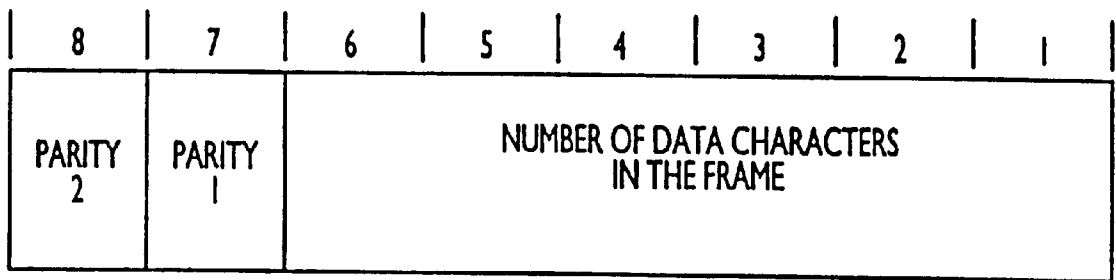

Fig. 22



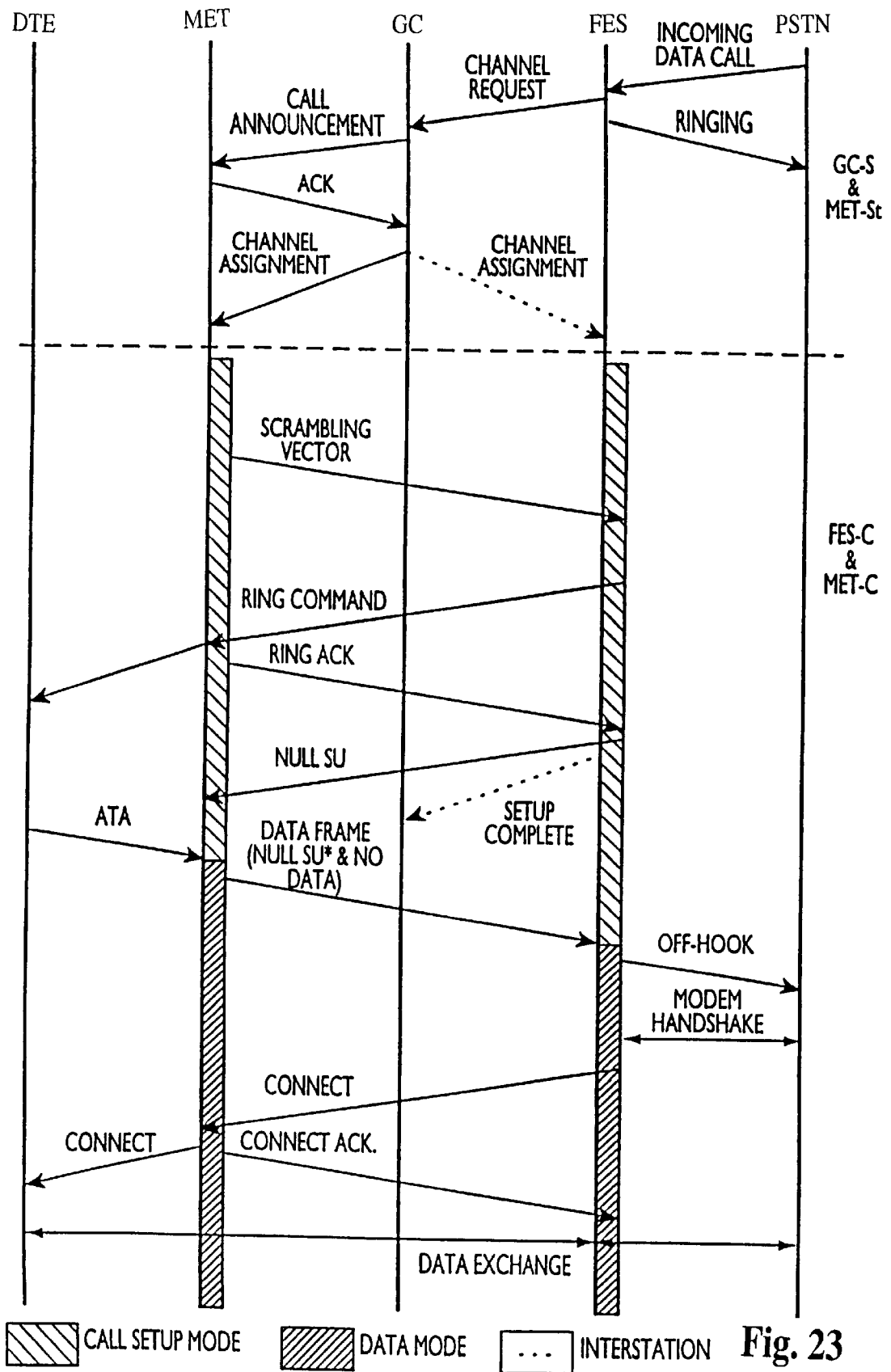
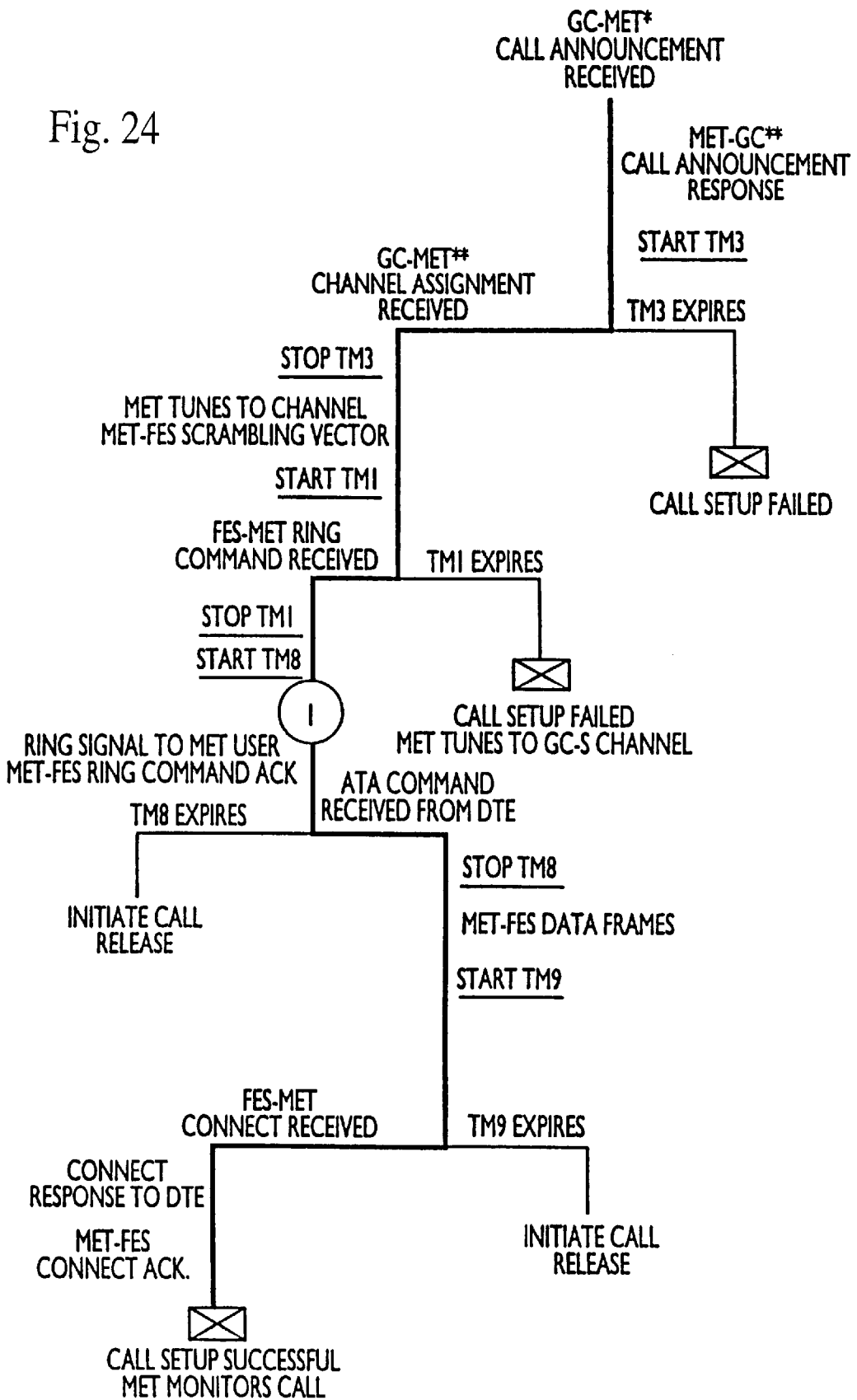

Fig. 23

Fig. 24



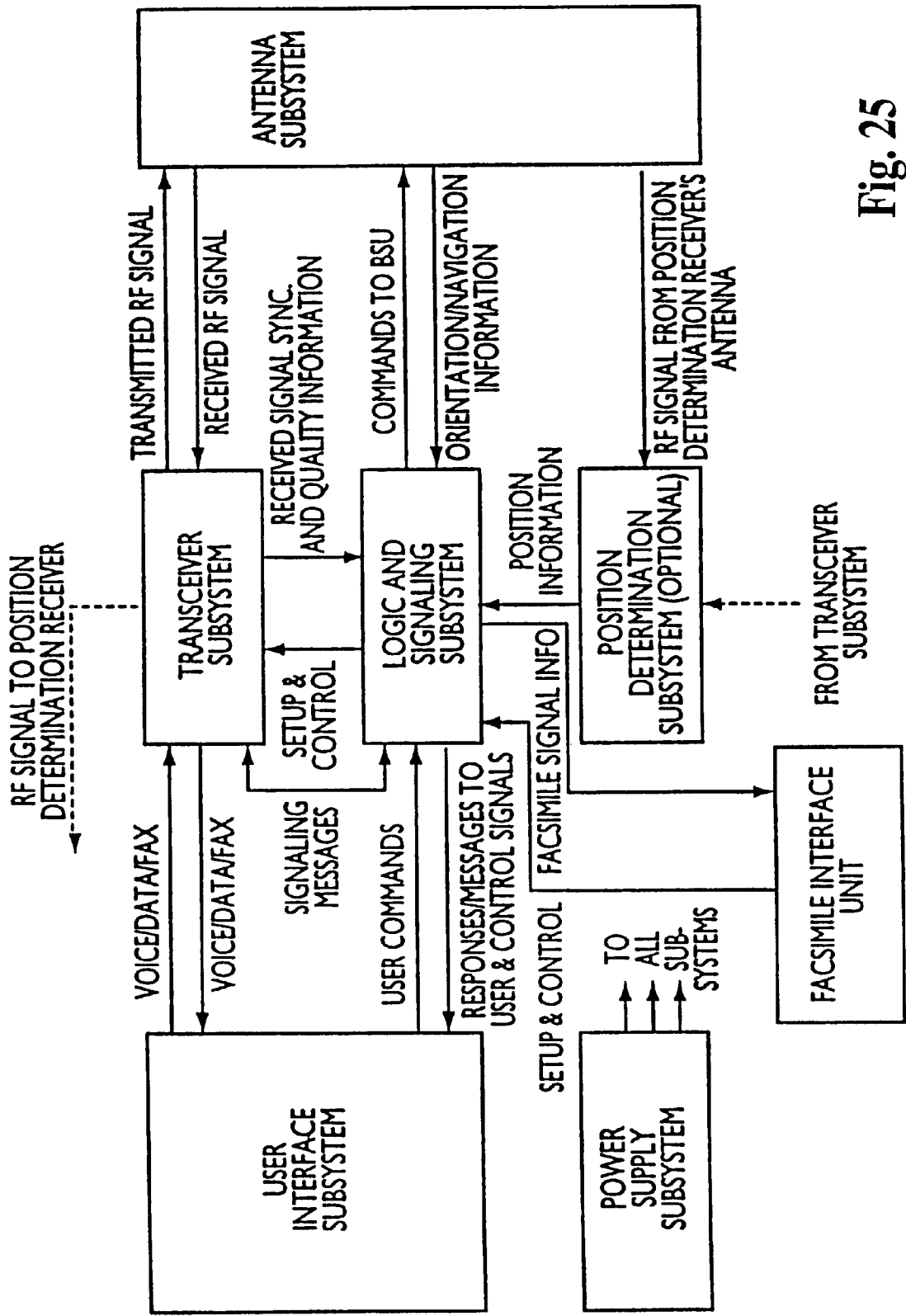

Fig. 25

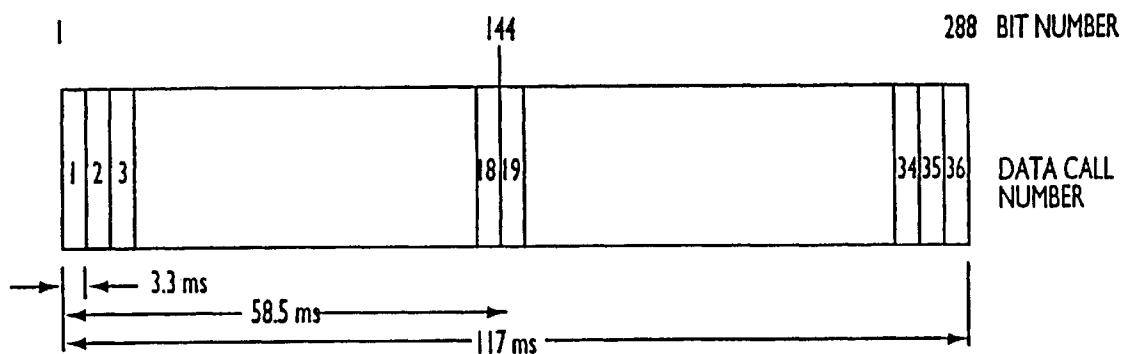

Fig. 26

Fig. 27

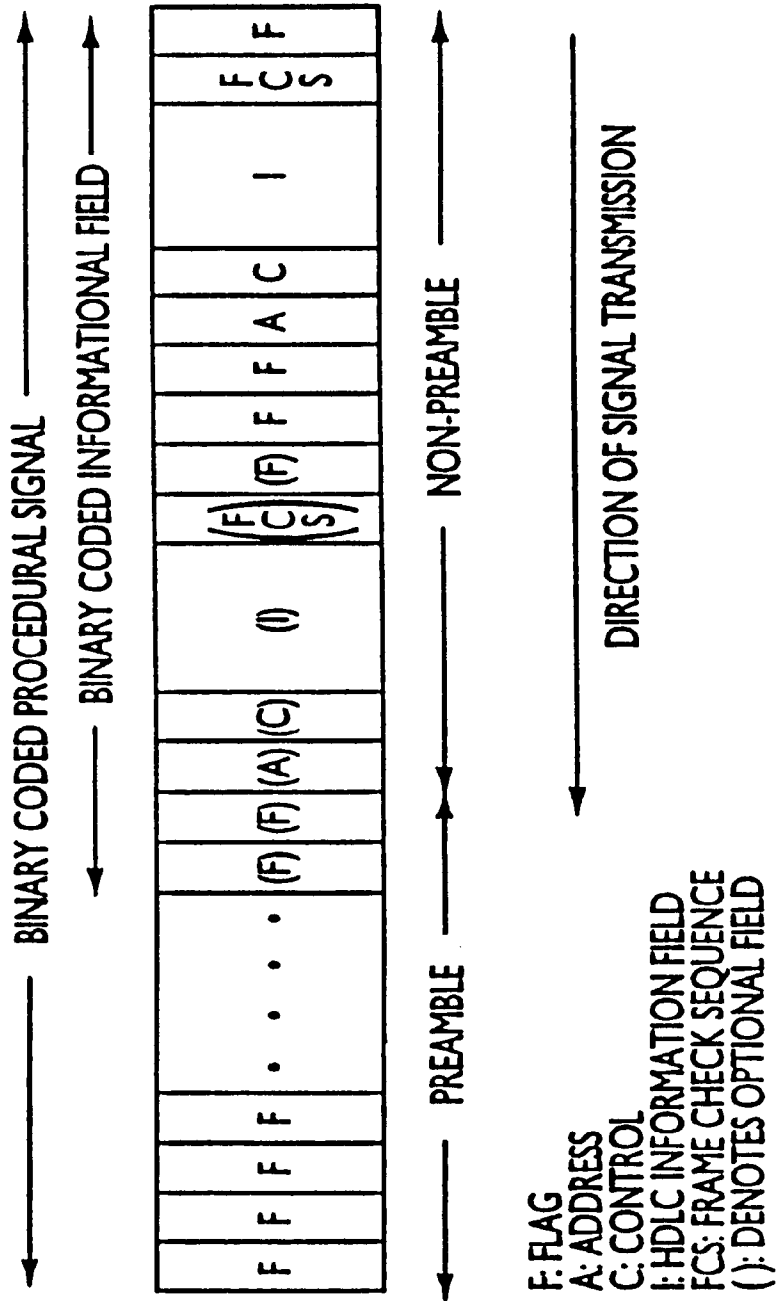
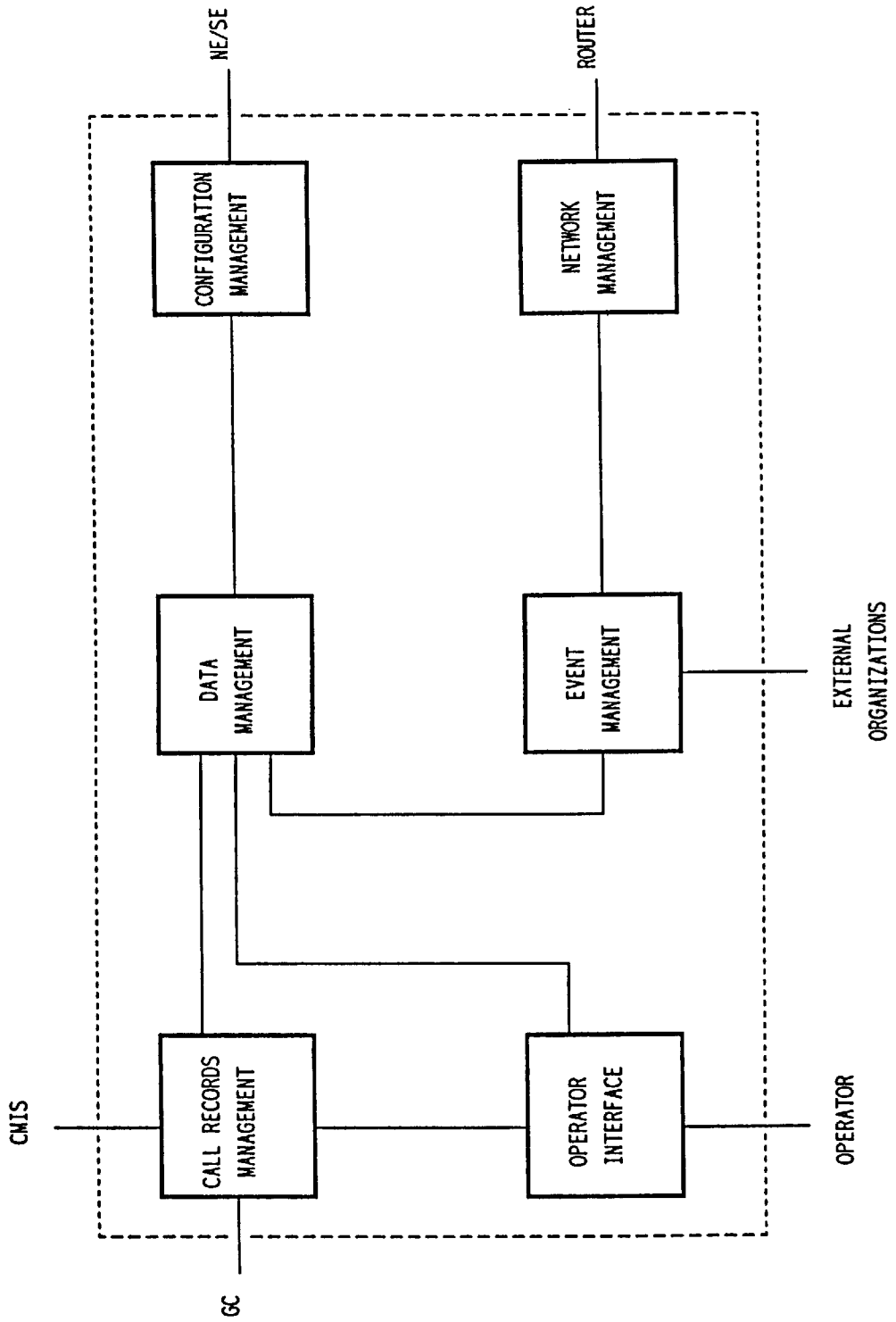

Fig. 28



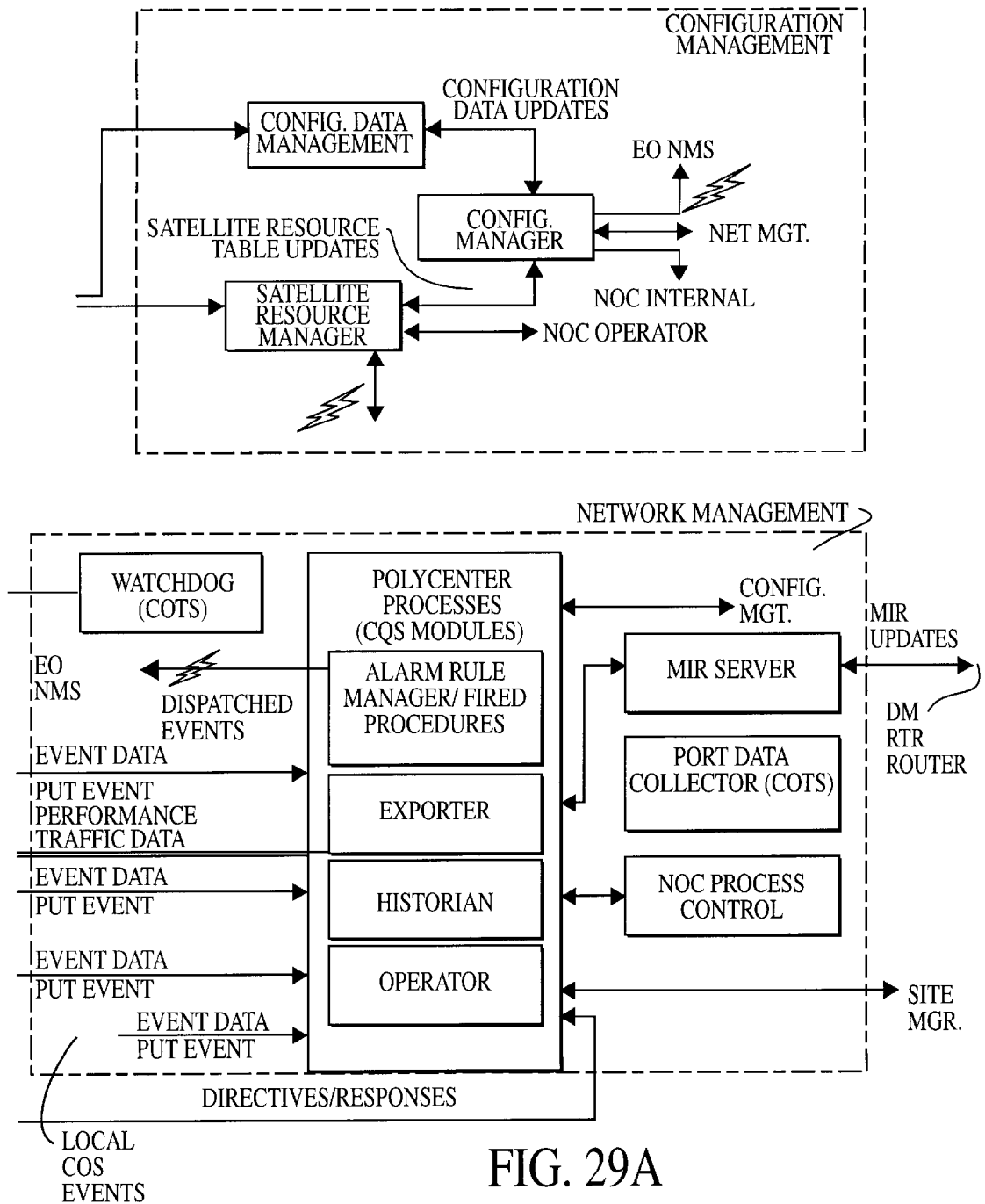

FIG. 29A

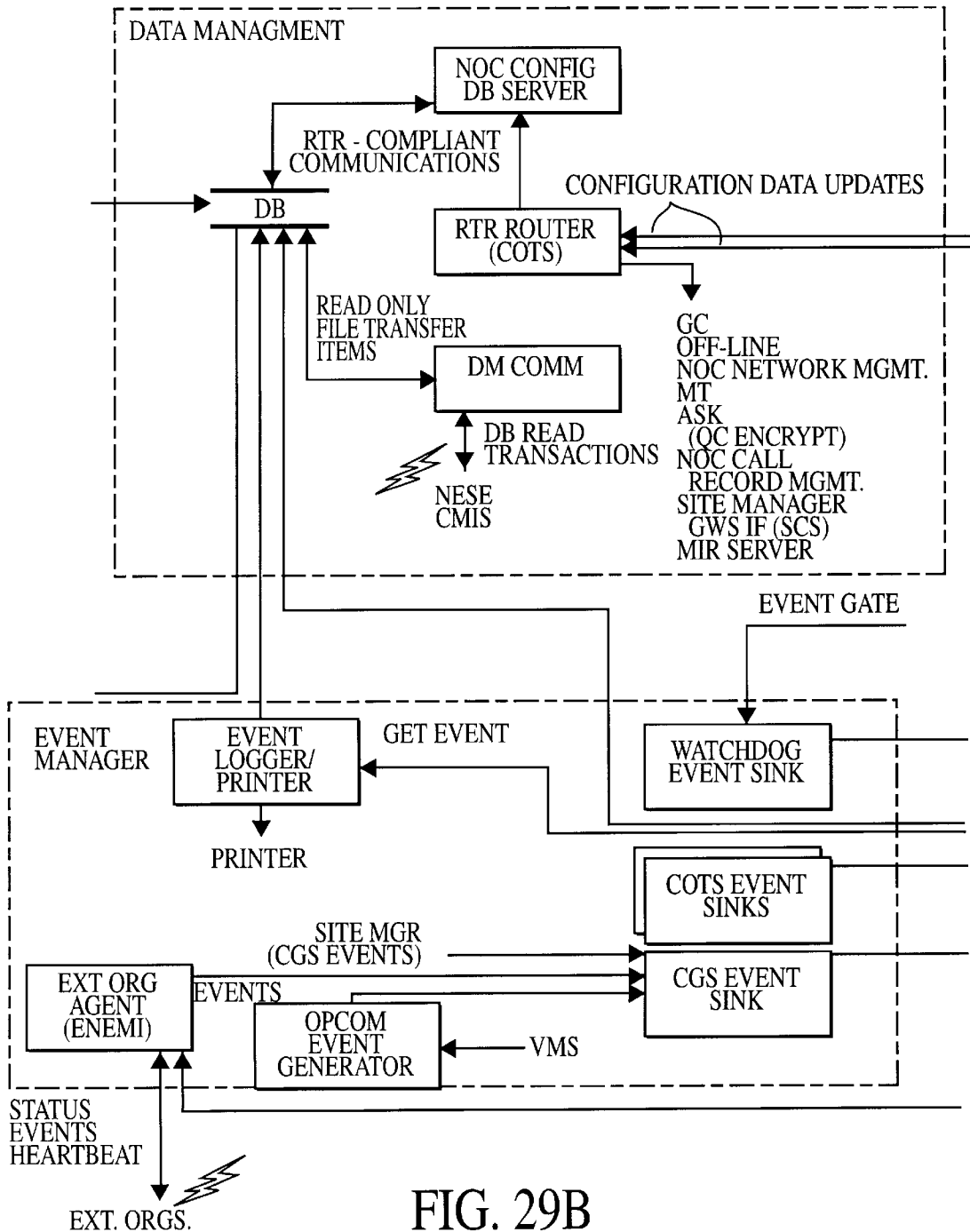
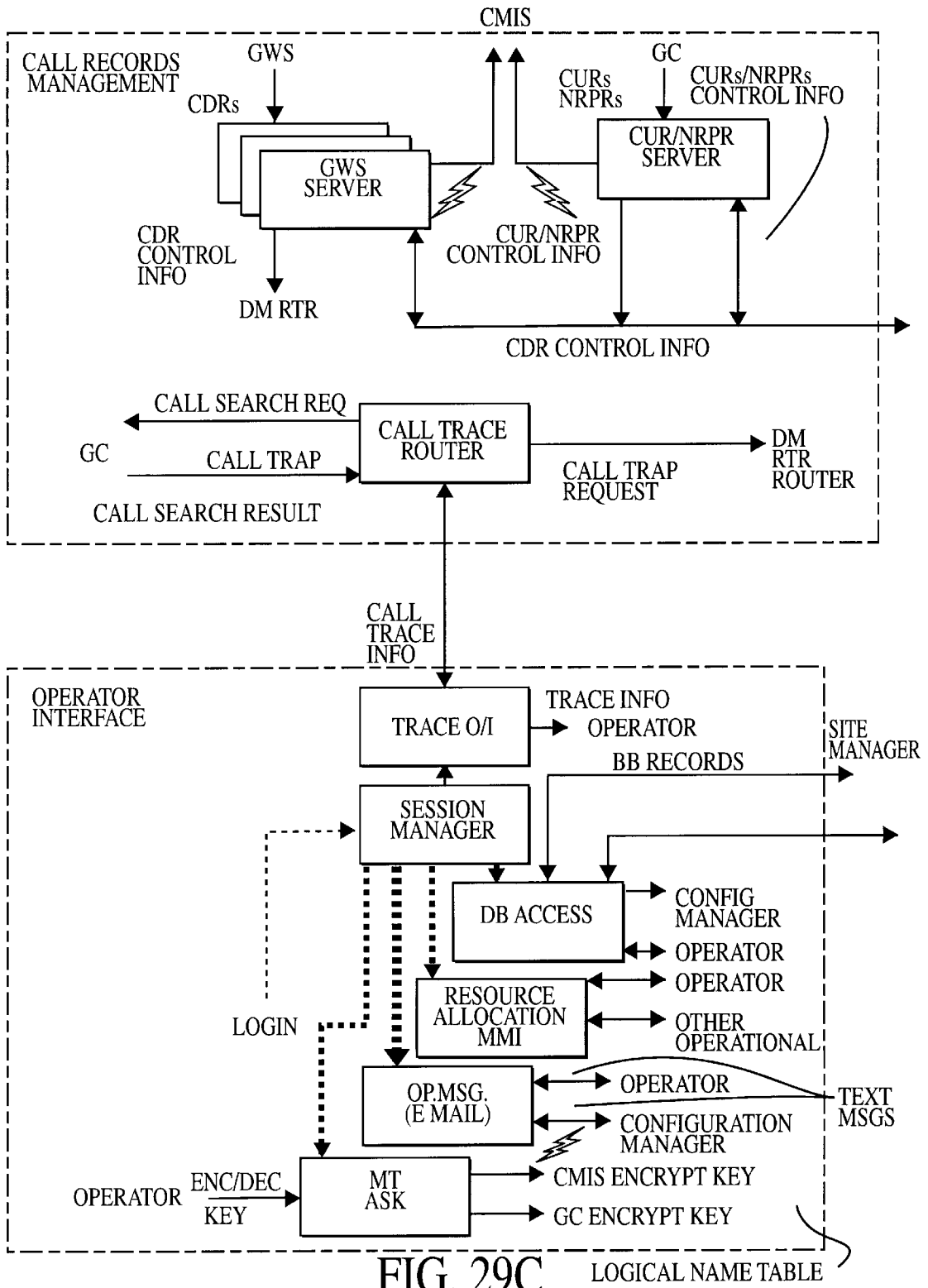

FIG. 29B





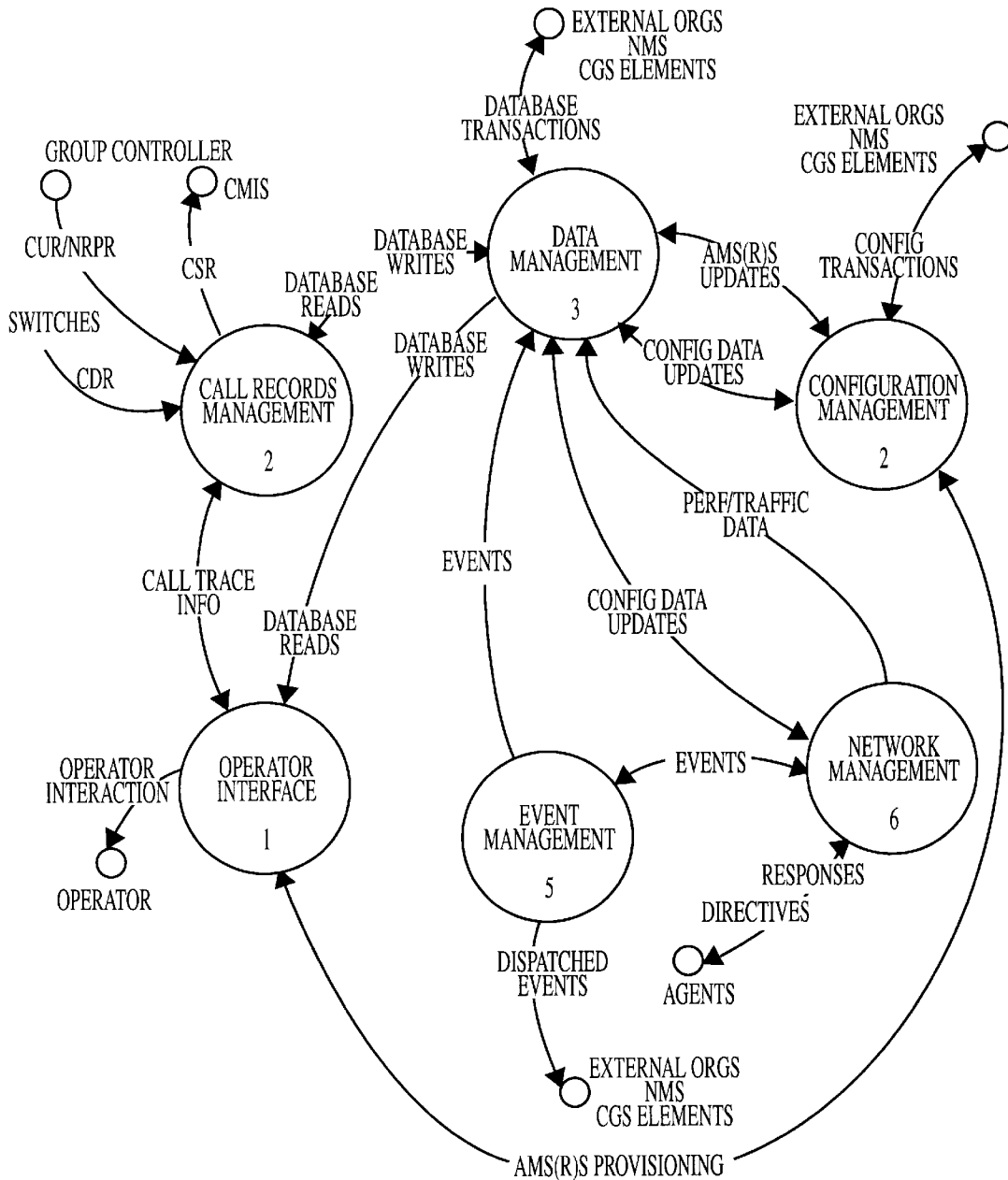

FIG. 30

## NETWORK OPERATIONS CENTER FOR MOBILE EARTH TERMINAL SATELLITE COMMUNICATIONS SYSTEM

### CROSS-REFERENCE TO RELATED APPLICATION

This application claims priority to U.S. Provisional Application Ser. No. 60/007,748, filed Nov. 30, 1995 and incorporated herein by reference. This application, additionally, is related to U.S. patent application Ser. No. 08/565,036 filed on Nov. 30, 1995, of Tisdale et al. entitled "Fraud Detection and User Validation System For Mobile Earth Terminal Communication Device," the disclosure of which is incorporated herein by reference.

### TECHNICAL FIELD

The present invention relates generally to a mobile satellite services system, and more particularly, to a network operations center for a mobile earth terminal satellite communication network. The mobile earth terminal (MET) provides voice, data, and facsimile transmission between mobile earth terminals and feederlink earth stations (FESS) that act as gateways to public networks or base stations associated with private networks.

### BACKGROUND ART

An overview of a satellite network system, such as disclosed in the above-identified related application, is illustrated in FIG. 1. The satellite network system design provides the capability for METs and FESSs to access one or more multiple beam satellites located in geostationary orbit to obtain communications services.

The heart of the satellite network system for each of the networks is the Network Control System (NCS) which monitors and controls each of the networks. The principal function of the NCS is to manage the overall satellite network system, to manage access to the satellite network system, to assign satellite circuits to meet the requirements of mobile customers and to provide network management and network administrative and call accounting functions.

The satellites each transmit and receive signals to and from METs at L-band frequencies and to and from Network Communications Controllers (NCCs) and Feederlink Earth Stations (FESS) at Ku-band frequencies. Communications at L-band frequencies is via a number of satellite beams which together cover the service area. The satellite beams are sufficiently strong to permit voice and data communications using inexpensive mobile terminals and will provide for frequency reuse of the L-band spectrum through inter-beam isolation. A single beam generally covers the service area.

The satellite network system provides the capability for mobile earth terminals to access one or more multiple beam satellites located in geostationary orbit for the purposes of providing mobile communications services. The satellite network system is desired to provide the following general categories of service.

Mobile Telephone Service (MTS) provides point-to-point circuit switched voice connections between mobile and public switched telephone network (PSTN) subscriber stations. Calls can be originated by either the mobile terminal or terrestrial user. Mobile terminal-to-mobile terminal calls are also supported.

Mobile Radio Service (MRS) provides point-to-point circuit switched connections between mobile terminal subscriber stations and subscriber stations in a private network

(PN) which is not a part of the PSTN. Calls can be originated from either end. Mobile terminal-to-mobile terminal calls are also supported.

Mobile Telephone Cellular Roaming Service (MTCRS) provides Mobile Telephone Service to mobile subscribers who are also equipped with cellular radio telephones. When the mobile terminal is within range of the cellular system, calls are serviced by the cellular system. When the mobile terminal is not in range of the cellular system, the MTCRS is selected to handle the call and appears to the user to be a part of the cellular system. Calls can be originated either from the MET or the PSTN. Mobile terminal-to-mobile terminal calls are also supported.

NET Radio (NR) service provides point-to-multipoint circuit switched connections between mobile terminal subscriber stations and a central base station. Mobile users are able to listen to two-way conversations and to transmit using a push-to-talk mode of operation.

Mobile Data Service (MDS) provides a packet switched connection between a data terminal equipment (DTE) device at a mobile terminal and a data communications equipment (DCE)/DTE device connected to a public switched packet network. Integrated voice/data operation is also supported.

The satellites are designed to transmit signals at L-band frequencies in the frequency band 1530–1559 MHz. They will receive L-band frequencies in the frequency band 1631.5–1660.5 MHz. Polarization is right hand circular in both bands. The satellites will also transmit in the Ku frequency band, 10,750 MHz to 10,950 MHz, and receive Ku-band signals in the frequency band 13,000 to 13,250 MHz.

The satellite transponders are designed to translate communications signals accessing the satellite at Ku-band frequencies to an L-band frequency in a given beam and vice versa. The translation will be such that there is a one-to-one relation between frequency spectrum at Ku-band and frequency spectrum in any beam at L-band. The satellite transponders will be capable of supporting L-band communications in any portion of the 29 MHz allocation in any beam.

Transponder capacity is also provided for Ku-band uplink to Ku-band down-link for signalling and network management purposes between FESSs and NCCs. The aggregate effective isotropic radiated power (AEIRP) is defined as that satellite e.i.r.p. that would result if the total available communications power of the communications subsystem was applied to the beam that covers that part of the service area. Some of the key performance parameters of the satellite are listed in FIG. 2.

The satellite network system interfaces to a number of entities which are required to access it for various purposes. FIG. 3 is a context diagram of the satellite network system illustrating these entities and their respective interfaces. Three major classes of entities are defined as user of communications services, external organizations requiring coordination, and network management system.

The users of satellite network communications services are MET users who access the satellite network system either via terrestrial networks (PSTN, PSDN, or Private Networks) or via METs for the purpose of using the services provided by the system. FES Owner/Operators are those organizations which own and control FESSs that provide a terrestrial interface to the satellite network. When an FES becomes a part of the satellite network, it must meet specified technical performance criteria and interact with and accept real-time control from the NCCs. FES Owner/

Operators determine the customized services that are offered and are ultimately responsible for the operation and maintenance of the FES. Customers and service providers interact with the Customer Management Information System within the Network Management System.

The satellite network system interfaces to, and performs transactions with, various operational units to implement its functions. Interaction with a Satellite Operations Center (SOC) enables the system to maintain cognizance of the availability of satellite resources (e.g. in the event of satellite health problems, eclipse operations, etc.) and, from time to time, to arrange for any necessary satellite reconfiguration to meet changes in traffic requirements.

A satellite network management system (NMS) is normally located at an administration's headquarters and may comprise three major functional entities: Customer Management Information System (CMIS), Network Engineering, and System Engineering (NE/SE). These entities perform functions necessary for the management and maintenance of the satellite network system that are closely tied to the way the administration intends to do business.

CMIS provides customers and service providers with assistance and information including problem resolution, service changes, and billing/usage data. Customers include individual MET owners and fleet managers of larger corporate customers. Service providers are the retailers and maintenance organizations that interact face to face with individual and corporate customers.

Network Engineering (NE) develops plans and performs analysis in support of the system. NE analyzes the requirements of the network. It reconciles expected traffic loads with the capability and availability of space and ground resources to produce frequency plans for the different beams within the system. Contingency plans are defined for failure situations. System Engineering (SE) engineers the subsystems, equipment and software that is needed to expand capacity to meet increases in traffic demands and to provide new features and services which become marketable to subscribers.

Necessary to the successful interaction of the various stations in the communications system is the appropriate interface between the satellites and the network. Delivery of messages must be coordinated. As the satellite network system interfaces with outside organizations that lease resources on satellite network, such resources must be allocated and managed in a manner suited to the users' needs. Still other outside users do not lease resources on satellite network satellites but require operational coordination.

#### DISCLOSURE OF THE INVENTION

The present invention meets the needs described above at least in part by provisions of a network operations center (NOC) that performs network management functions for a mobile satellite communications system. The mobile satellite system includes a satellite communication switching office having a satellite antenna for receiving/transmitting a satellite message via a satellite from/to a vehicle using a mobile communication system, a satellite interface system, a central controller receiving/transmitting the satellite message from/to the satellite communication switching office issued from the vehicle via the satellite and the satellite interface system. The mobile communication system includes a user interface system providing a user interface through which a user has access to services supported by the mobile satellite system, and an antenna system providing an

interface between the mobile communication system and the mobile satellite system via the satellite interface system, and receiving a first satellite message from the satellite and transmitting a second satellite message to the satellite. The mobile communication system also includes a transceiver system, operatively connected to the antenna system, including a receiver and a transmitter. The transmitter converts the second satellite message including at least one of voice, data, fax and signaling signals into a modulated signal, and transmits the modulated signal to the antenna system. The receiver accepts the first satellite message from the antenna system and converts the first satellite message into at least one of voice, data, fax and signaling signals, at least one of the voice, data and fax signals routed to the user interface system. The receiver includes a second converter with an associated second frequency synthesizer, a demodulator, and a demultiplexer for at least one of voice, fax, and data. The mobile communication system also includes a logic and signaling system, operatively connected to the transceiver, controlling initialization of the mobile communication system, obtaining an assigned outbound signaling channel from which updated system information and commands and messages are received. The logic and signaling system configures the transceiver for reception and transmission of at least one of voice, data, fax and signaling messages, and controls protocols between the mobile communication system and the mobile satellite system, and validating a received signalling messages and generating codes for a signaling message to be transmitted.

The NOC manages and controls the resources of the satellite network system and carries out the administrative functions associated with the management of the total satellite network system. The NOC communicates with the various internal and external entities via a local area network (LAN) /wide area network (WAN) based satellite network Internetwork and dial-up lines.

Network management functions include measuring the usage of resources by customers to enable predictions of what changes to make in the future deployment of resources. Such resources may be network elements and CPUs in the system. Data such as usage records are collected and analysis of capacity planning is performed based on present characteristics. Security functions are provided wherein the network is protected against unauthorized use. Security mechanisms built in to the network management include enhanced fraud security coding encryption and user passwords. Configuration management, i.e., how resources are allocated, is another function of the NOC. Fault detection and management are provided for by the NOC. Problems are isolated and reported to operations personnel who can react to the problems.

Advantages of the improved system and the manner in which the functions are provided will become apparent from the detailed disclosure with the accompanying drawings set forth herein.

#### BRIEF DESCRIPTION OF DRAWINGS

FIG. 1 is a diagram illustrating an overview of the satellite network system;

FIG. 2 is a diagram illustrating key performance parameters of the satellite used in the satellite network system;

FIG. 3 is a diagram of the satellite network system illustrating components and respective interfaces;

FIG. 4 is a diagram of a satellite network system illustrating a number of system elements and their interconnecting communications links;

FIG. 5 is a basic block diagram of the NOC and its interfaces;

FIG. 6 is a basic block diagram of the physical architecture of the mobile earth terminal;

FIG. 7 is a basic block diagram of the functions of the mobile earth terminal;

FIGS. 8A-8C are diagrams of different transceiver configurations;

FIG. 9A is a diagram of the format of a typical signalling unit;

FIG. 9B illustrates the basic signalling architecture in the satellite communication system;

FIG. 10 is a diagram of the frame formats and relationships of the out of band signaling channels;

FIG. 11 is a diagram of a typical example of a communication channel format, in this case voice mode in-band signaling;

FIG. 12 is a diagram of the relationship of MGSP to other signaling layers in the GC and the MET;

FIG. 13 is a diagram of the improved call setup protocol used to establish a MET originated voice call;

FIG. 14 is a diagram of the improved protocol used for PSTN originated calls;

FIG. 15 is a diagram of a visitor registration sequence of the MET;

FIG. 16 is a diagram of the multiple operating modes of the mobile earth terminal;

FIG. 17A is a basic block diagram of the functions of the mobile earth terminal including the digital equipment terminal functions;

FIG. 17B is a diagram of a data call setup sequence between the MET and a PSTN;

FIGS. 18 and 19 are event tree diagrams of a call setup sequence between the MET and a PSTN;

FIG. 20 is a diagram of a call release sequence initiated by the MET;

FIG. 21 is a diagram of a call release sequence initiated by the PSTN;

FIG. 22 is a diagram of a data field format;

FIG. 23 is a diagram of a call setup sequence between the PSTN and MET;

FIG. 24 is an event tree diagram of a call setup sequence between the PSTN and MET;

FIG. 25 is a basic block diagram of the functions of the mobile earth terminal including the facsimile interface unit functions;

FIG. 26 is a diagram of a binary coded procedural signal;

FIG. 27 is a diagram of a data field format at 2400 bit/s.

FIG. 28 is a block diagram of an improved NOC functional architecture.

FIGS. 29A-29C are diagrams of the NOC architecture in more detail.

FIG. 30 is a NOC data flow diagram, depicting the NOC top-level CSCs and the interfaces between them.

#### BEST MODE FOR CARRYING OUT THE INVENTION

The satellite network system comprises a number of system elements and their interconnecting communications links as illustrated in FIG. 4. The system elements are the NOC, the NCC, the FES, the MET, the Remote Monitor Station (RMS), and the System Test Station (STS). The

interconnecting communications links are the satellite network Internetwork, terrestrial links, the MET signaling channels, the Interstation signaling channels, and the MET-FES communications channels.

The NCC manages the real time allocation of circuits between METs and FESs for the purposes of supporting communications. The available circuits are held in circuit pools managed by Group Controllers (GCs) within the NCC. The NCC communicates with the NOC via the satellite network Internetwork, with FESs via Ku-to-Ku band interstation signaling channels or terrestrial links, and with mobile terminals via Ku-to-L band signaling channels.

The FES supports communications links between METs, the PSTN, private networks, and other METs. Once a channel is established with an MET, call completion and service feature management is accomplished via In-Band signaling over the communication channel. Two types of FESs have been defined for the satellite network system; Gateway FESs and Base FESs. Gateway FESs provide MTS and MTCRS services. Base FESs provide MRS and NR services.

The MET provides the mobile user access to the communications channels and services provided by the satellite network system. A range of terminal types has been defined for the satellite network system.

The RMS monitors L-band RF spectrum and transmission performance in specific L-band beams. An RMS is nominally located in each L-band beam. Each RMS interfaces with the NOC via either a satellite or terrestrial link.

The STS provides an L-band network access capability to support FES commissioning tests and network service diagnostic tests. The STS is collocated with, and interfaced to, the NOC.

Communications channels transport voice transmissions between METs and FESs via the satellite. Connectivity for MET-to-MET calls is accomplished by double hopping the communications channels via specially equipped FESs. Signaling channels are used to set up and tear down communications circuits, to monitor and control FES and MET operation, and to transport other necessary information between network elements for the operation of satellite network. The system provides Out-of-Band and Interstation signaling channels for establishing calls and transferring information. In-Band signaling is provided on established communications channels for supervisory and feature activation purposes. A detailed description of the satellite network signaling system architecture is provided in L. White, et al., "North American Mobile Satellite System Signaling Architecture," AIAA 14th International Communications Satellite Conference, Washington, DC (March 1992), incorporated herein by reference.

The satellite network Internetwork provides interconnection among the major satellite network ground system elements such as the NOCs, NCCs, and Data Hubs, as well as external entities. Various leased and dial-up lines are used for specific applications within the satellite network system such as backup interstation links between the NCC and FESs and interconnection of RMSs with the NOC.

The primary function of the NOC is to manage and control the resources of the satellite network system. FIG. 5 is a basic block diagram of the NOC and its interface. The NOC computer is shown with network connections, peripheral disks, fault tolerant features, and expansion capabilities to accommodate future growth. The NOC software is represented as two major layers, a functional layer and a support layer. The functional layer represents the application

specific portion of the NOC software. The support layer represents software subsystems that provide a general class of services and are used by the subsystems in the functional layer.

The application specific functions performed by the NOC are fault management, accounting management, configuration management, performance management, and security management. The general NCC Terminal Equipment (NCCTE) configuration showing constituent equipment includes processing equipment, communications equipment, mass storage equipment, man-machine interface equipment, and optional secure MET Access Security Key (ASK) storage equipment. The Processing Equipment consists of one or more digital processors that provide overall NCC control, NCS call processing, network access processing and inter-network communications processing.

The Communications Equipment comprises satellite signaling and communications channel units and FES terrestrial communication link interface units. The Mass Storage Equipment provides NCC network configuration database storage, call record spool buffering an executable program storage. The Man-Machine Interface Equipment provides operator command, display and hard copy facilities, and operator access to the computer operating systems. The MET ASK storage Equipment provides a physically secure facility for protecting and distributing MET Access Security Keys.

The NCCTE comprises three functional subsystems: NCCTE Common Equipment Subsystem, Group Controller Subsystem, and Network Access Subsystem. The NCCTE Common Equipment subsystem comprises an NCC Controller, NCCTE mass storage facilities, and the NCCTE man-machine interface. The NCC Controller comprises processing and database resources that perform functions common to multiple Group Controllers. These functions include satellite network Internetwork communications, central control and monitoring of the NCCTE and NCCRE, storage of the network configuration, buffering of FES and Group Controller call accounting data, transfer of transaction information to the Off-line NCC and control and monitoring of FESs.

The Mass Storage element provides NCC network configuration database storage, call accounting data spool buffering, and NCCTE executable program storage. The Man-machine Interface provides Operator command and display facilities for control and monitoring of NCC operation and includes hard copy facilities for logging events and alarms. A Group Controller (GC) is the physical NCC entity having hardware and software processing resources that provide real time control according to the CG database received from the NOC.

The Group Controller Subsystem may incorporate one to four Group Controllers. Each Group Controller maintains state machines for every call in progress within the Control Group. It allocates and de-allocates circuits for FES-MET calls within each beam of the system, manages virtual network call processing, MET authentication, and provides certain elements of call accounting. When required, it provides satellite bandwidth resources to the NOC for AMS (R)S resource provisioning. The Group Controller monitors the performance of call processing and satellite circuit pool utilization. It also performs MET management, commissioning and periodic performance verification testing.

The Network Access Subsystem contains satellite interface channel equipment for Out-of-Band signaling and Inter-station Signaling which are used to respond to MET and FES

requests for communications services. The Network Access Processor also includes MET communications interfaces that are used to perform MET commission testing. In addition, the subsystem includes terrestrial data link equipment for selected FES Interstation Signaling.

The principal function of the FES is to provide the required circuit switched connections between the satellite radio channels, which provide communications links to the mobile earth terminals, and either the PSTN or PN. FESs will be configured as Gateway Stations (GS) to provide MTS and MTCRS services or Base Stations to provide MRS and Net Radio services. Gateway and Base functions can be combined in a single station.

The FES operates under the real time control of the Network Communications Controller (NCC) to implement the call set-up and take-down procedures of the communications channels to and from the METs. Control of the FES by the NCC is provided via the interstation signaling channels. An FES will support multiple Control Groups and Virtual Networks. The FES is partitioned into two major functional blocks, the FES RF Equipment (FES-RE) and the FES Terminal Equipment (FES-TE). The principal function of the FES-RE is to provide the radio transmission functions for the FES. In the transmit direction it combines all signals from the communications and interstation signaling channel unit outputs from the FES-TE, and amplifies them and up-convert these to Ku-Band for transmission to the satellite via the antenna. In the receive direction, signals received from the satellite are down-converted from Ku-Band, amplified and distributed to the channel units within the FES-TE. Additional functions include satellite induced Doppler correction, satellite tracking and uplink power control to combat rain fades.

The principal function of the FES-TE is to perform the basic call processing functions for the FES and to connect the METs to the appropriate PSTN or PN port. Under control of the NCC, the FES assigns communications channel units to handle calls initiated by MET or PSTN subscribers. The FES-TE also performs alarm reporting, call detail record recording, and provision of operator interfaces.

For operational convenience, an FES may in some cases be collocated with the NCC. In this event, the NCC RF Equipment will be shared by the two system elements and the interstation signaling may be via a LAN. Connection to and from the PSTN is via standard North American interconnect types as negotiated with the organization providing PSTN interconnection. This will typically be a primary rate digital interconnect. Connection to and from private networks is via standard North American interconnect types as negotiated with the organization requesting satellite network service. This will typically be a primary rate digital interconnect for larger FESs. FESs equipped with only a limited number of channels may have an analog interconnect.

The MET includes all of the communication and control functions necessary to support communications from a vehicle or fixed remote site using the resources of the satellite network system. FIGS. 6 and 7 are basic block diagrams of the physical architecture and functions of the mobile earth terminal. The basic functional diagram of FIG. 7 is implemented by baseband processing and RF electronics of FIG. 6. A standard voice coder/decoder receives coded messages from the baseband processing and RF electronic system and decodes the message received from the satellite antenna unit for delivery to the interface unit that includes standard user interfaces. Baseband processing and RF electronics receive satellite communications responsive with

low noise amplifier (LNA) and output signals for transmission using the diplexer of the antenna unit. Baseband processing and RF electronics also outputs signals for use with beam steering antennas as will be discussed below. Advantageously, the mobile earth terminal is functional with antennas that are either steerable or nonsteerable.

The functional subsystems comprising the MET are shown in FIG. 7 and include the user interface, transceiver, antenna, logic and signaling, power supply subsystems, and Position Determination subsystem. The baseline MET will have a low gain directional antenna in the antenna subsystem. The satellite network system supports communications with METs using omnidirectional and higher gain directional antennas.

The user interface subsystem provides the user interfaces through which the user has access to the services supported by the satellite network system. Depending on the service(s) the MET will be equipped with one or more of the devices or ports. The transceiver subsystem consists of a receiver and a transmitter. Examples of transceiver configurations are shown in FIGS. 8a-8c. The transmitter accepts voice, data, fax and signaling signals and converts them to a modulated RF signal. The transmit RF signal is routed to the antenna subsystem. The transmitter typically consists of the high power amplifier (HPA), the upconverter with its associated frequency synthesizer, the modulators and the modules for voice, Fax, or data encoding, multiplexing, scrambling, FEC encoding, interleaving and frame formatting.

The receiver accepts modulated RF signals from the antenna subsystem and converts them into voice, data, fax or signaling signals as appropriate. The voice, data and fax signals are routed to the user interface subsystem. The receiver typically consists of the downconverter with its associated frequency synthesizer, the demodulator, and the modules for frame de-formatting, de-interleaving, FEC decoding, descrambling, demultiplexing and voice, Fax, or data decoding. The transceiver communicates over one channel in each direction at any one time. Thus, the transceiver subsystem will typically consist of only one receiver and one transmitter. However, the MET may also incorporate a pilot receiver for antennas and frequency tracking purposes, or a complete receiver dedicated to the continuous reception of the signaling channel from the Group Controller. Three different transceiver/receiver configurations are illustrated in FIGS. 8(a)-8(c).

The antenna subsystem provides the MET interface to the satellite network and is responsible for receiving the RF signal from the satellite and transmitting the RF signal generated by the MET towards the satellite. The subsystem typically includes an antenna which may be either directional or omnidirectional, a diplexer, a low noise amplifier (LNA), an optional beam steering unit (BSU) if a directional antenna is used, a device such as a compass or an inertial sensor for the determination of the orientation of the vehicle, and an antenna for the position determination receiver.

The logic and signaling subsystem acts as the central controller for the MET. Its basic functions are to initialize the MET by performing a self test at power up and control, based on a resident system table, the acquisition of one of the METs assigned outbound signaling channels from which updated system information and commands and messages from the GC are derived. The logic and signaling subsystem sets up and configures the transceiver for the reception and transmission of voice, data, fax or signaling messages as appropriate. The logic and signaling subsystem also handles the protocols between the MET and the FES and between the

MET the GC via signaling messages, and checks the validity of the received signaling messages (Cyclic Redundance Check (CRC)) and generates the CRC codes for the signaling message transmitted by the MET.

The logic and signaling subsystem also interprets the commands received from the local user via the user interface subsystem (e.g. on/off hook, dialled numbers, etc.) and take the appropriate actions needed, and generates, or commands the generation, of control signals, messages and indications to the user through the user interface subsystem. The logic signaling system also controls the beam steering unit (if any) in the antenna subsystem, and monitors and tests all the other subsystems. In case of fault detection, it informs the user about the failure and take the appropriate measures needed to prevent harmful interference to the satellite network or other system.

The power supply subsystem provides power to all other subsystems. The external voltage source to which this subsystem interfaces depends on the type of vehicle on which the MET is mounted, e.g. 12/24 Volts DC for land vehicles.

A standard receiver such as a GPS or a Loran-C receiver is also provided for the determination of the position of the vehicle. This information is used by the logic and signaling subsystem for beam steering (if used) or for applications such as position reporting. The position determination system is implemented externally to the MET and interfaced through a dedicated data port in the user interface subsystem.

The function of the Remote Monitor System is to continuously monitor the activity on each GC-S channel and to monitor the activity within the downlink L-band spectrum in the beam in which it is located. An RMS will be located in every beam carrying satellite network traffic. An RMS may be a stand alone station or collocated with the NCC or an FES. The RMS is controlled by the NOC and communicates via leased lines or the interstation signaling channels if collocated with an FES. The RMS detects anomalous conditions such as loss of signal, loss of frame sync, excessive BER, etc. on the GC-S channels and generates alarm reports which are transmitted to the NOC via the leased line interface. In addition, it monitors BER on any channel and power and frequency in any band as instructed by the NOC.

The primary functions of the System Test Stations (STS) is to provide commission testing capability for every channel unit in a FES and to provide readiness testing for the Off-Line NCC. The STS is collocated with and controlled by the NOC and will comprise one or more specifically instrumented METS. The STS provides a PSTN dial-up port for making terrestrial connections to FESs to perform MET to terrestrial end-to-end testing. The STS also provides a LAN interconnection to the NOC to provide access to operator consoles and peripheral equipment.

Advantageously, the MET combines three different features for the delivery and transmission of voice and data. These three features are the ability to initiate and transmit a data call, the ability to initiate and transmit a facsimile digital call, and the ability to roam between satellite and terrestrial based wireless communication systems. The following documents, representing applicable transmission protocols, are hereby incorporated by reference: EIA/IS-41B Cellular Radio Telecommunications Inter-System Operations; EIA/TIA-553-1989 "Cellular System Mobile Station—Land Station Compatibility Standard"; EIA/TIA-557; EIA/IS-54B.

The MSS signaling system provides the communications capability between network elements required to set up and

release communications circuits, provide additional enhanced services, and support certain network management functions. The network elements discussed above include group controllers (GCs), feederlink earth stations (FESs), and mobile earth terminals (METS). The seven different channel types are:

GC-S	Outbound TDM signaling channel from the GC to the METs.
MET-ST	Inbound TDMA signaling channel from the MET to the GC.
MET-SR	Inbound random access signaling channel from the MET to the GC.
FES-C	Outbound communications and inband signaling channel from a FES to a MET.
MET-C	Inbound communications and inband signaling channel from a MET to a FES.
GC-I	Interstation signaling channel from the GC to an FES.
FES-I	Interstation signaling channel from an FES to the GC.

FIG. 9B illustrates the basic signalling architecture in the satellite communication system. The basic element of communication for signaling and control for the MSS signaling system is the Signaling Unit (SU). The SU consists of 96 bits organized in 12 octets of 8 bits each. The first 80 bits comprise the message, and the last 16 a parity check, computed using the CCITT CRC-16 algorithm. The SU itself may take a variety of forms, depending on its use.

The format of a typical SU, in this case a MET request for access, is shown in FIG. 9A. For transmission, the SU is convolutionally encoded at either rate 3/4 or 1/2, adding an additional 32 or 96 bits respectively. In this example format, the message type is a 7 bit code that identifies the meaning of the SU, in this case a request for access to the MSS system for call placement. The MET-GC Signaling Protocol (MGSP) Header is an 8 bit field comprised of several sub-fields giving particular information related to the protocol such as message reference identification and the number of times the message has been retransmitted. Reverse terminal identification number (RTIN) is the MET's Electronic Serial Number, by which it identifies itself in transmissions on the MET-SR channel. Digits 1-10 represent the first 10 digits of the addressed telephone number in the PSTN or private network, in hexadecimal. If the 10th digit is set to "C", an address of greater than 10 digits is indicated. CRC is the 16-bit error detection code (Cyclic Redundancy Code).

The frame formats used in the GC-S, MET-SR and MET-ST channels are closely related, and are based on a common 360 millisecond superframe established on the GC-S channel. The frame formats and relationships of the out of band signaling channels are shown in FIG. 10.

In FIG. 10, all timing relationships in the MSS system signaling scheme are determined from the GC-S frame structure. The GC-S is operated in the QPSK mode at an aggregate rate of 6750 b/s. The stream is divided into superframes of 360 ms, comprising three 120 ms frames. Each frame is in turn comprised of a 24-bit unique word (UW), six SUs, eight flush bits and 10 unused bits, for a total of 810 bits and 120 ms. The first frame of a superframe is identified by inversion of the UW.

Mobile terminals throughout the area covered by any beam receive GC-S channels with a total uncertainty of approximately 32 ms, primarily due to their geographical locations. The received superframe boundary establishes the four 90 ms "slots" in the MET-SR random access channels, which operate in the BPSK mode at 3375 b/s. The actual random access burst is comprised of a 24-bit preamble, a

32-bit UW, a 128-bit SU (96 bits rate 3/4 coded), and eight flush bits, for a total of 192 bits in 56.9 ms. This allows a 33.1 ms guard time between bursts. Mobile Terminals select a MET-SR channel and slot at random from among the permitted choices.

The MET-ST TDMA channels, which also operate in the BPSK mode at 3375 b/s, are comprised of bursts that are equal in length to the GC-S frame, and which are also timed on the received frame boundary. The TDMA burst is made up of a 24-bit preamble, a 32-bit UW, a 192-bit SU (96 bits rate 1/2 coded), and eight flush bits. The total length of the TDMA burst is 256 bits in 75.9 ms, which allows a guard time of 44.1 ms. Mobile Terminals always respond to commands received on the GC-S on a METST channel which corresponds in number to the position of the command SU in the TDM frame. For example, the MET will respond to a command in SU slot 2 on MET-ST channel 2, and so forth. The response is always transmitted in the second frame time after receipt of the command, so that there is a minimum of 120 ms in which the MET can prepare its response.

The initial phase of establishing a call is handled by out-of-band signaling on the GC-S, MET-SR and MET-ST channels. This phase culminates in assignment of a pair of communication channels to the MET and FES. When these elements receive and tune to the communication channels, further signaling and control functions are accomplished using inband signaling. The communication channels, FESC and MET-C, use a variety of related TDM formats which are determined by the intended use of the link, i.e., voice, data, or facsimile and one of three possible primary modes: call setup (entirely signaling), communication (no signaling), or in-band signaling (an occasional subframe of 128 bits is used for signaling/control).

The same 96-bit SU described above is used to accomplish in-band signaling. A typical example of a communication channel format, in this case voice mode inband signaling is shown in FIG. 11.

The outbound TDM, inbound TDMA, and inbound random access channels provide signaling between the GC and each of the METS in the associated control group. All communications on these channels will be passed in the form of 96 bit (12 octet) messages known as signaling units. Each signaling unit will begin with a 1-octet message type field and end with a two-octet cyclic redundancy check. The MET to GC Signaling Protocol (MGSP) serves as the layer two protocol for these channels.

Communications from the group controller (GC) to the mobile terminals is provided by the Outbound TDM or GC-S channel. The primary function of this channel is to carry frequency assignments from the GC to individual METS. In addition, the Outbound TDM channel carries network status information which is received by all METs in a particular beam and control group. The outbound TDM channel operates at a rate of 6750 bits/s with rate 3/4 FEC. QPSK modulation and nominally 6.5 kHz channel spacing (other spacings are under investigation) is employed. These parameters are identical to those of the communications channel and were chosen to reduce MET complexity.

Inbound TDMA (MET-ST) channels are used by the MET to respond to actions initiated by the GC, such as responding to the call announcement issued by the GC to check a MET's availability to receive a PSTN originated or MET to MET call. The Inbound Random Access (MET-SR) channels are used by METs to request frequency S assignments and for other MET initiated actions. The inbound random access and



TDMA channels each operate at a rate of 2400 bits/s with rate 3/4 FEC. DPS modulation and nominally 7.5 kHz channel spacing is employed. This modulation scheme has been selected because of its robust performance in the presence of frequency offset and timing errors. It also exhibits superior performance relative to conventional BPSK in the presence of band-limiting and hard-limiting.

Each control group has associated with it a number of L-band beams over which it operates. In each of these L-band beams a control group has associated with it a distinct set of outbound TDM, inbound TDMA, and inbound random access channels. The number of signaling channels of each type in each set is determined based on the level of signaling traffic flowing between the GC and the METs in that control group in that L-band beam. As signaling traffic levels change, new signaling channels of each type are allocated to or deallocated from a particular set of channels. The frequencies used for outbound TDM, inbound TDMA, and inbound random access channels are included in the status information carrier in the bulletin board signaling units transmitted on the outbound TDM channel.

Each MET is assigned to one of the outbound TDM channels in the control group and beam to which it belongs. Each control group supports up to 16 outbound TDM channels in each beam. Each outbound TDM channel has associated with it up to 6 inbound TDMA channels. An inbound TDMA channel will only carry messages that are responses to messages received on the outbound TDM channel with which it is associated inbound random access channels will not associated with a particular outbound TDM channel. A MET chooses a inbound random access channel at random from among those associated with its control group and beam each time a message is to be transmitted. Each control group can support up to 64 inbound random access channels in each beam. Up to 64 of these channels may be used system wide to meet the signaling requirements of a fully loaded system supporting 5000 circuits.

Inband signaling channels (FES-C and MET-C) are provided between the FES and the MET. These channels are used to provide signaling for call setup and call release, and also provide the capability to pass other signaling information while a call is in progress. The FES-C and MET-C channels are operated in two separate modes in "call setup mode" only signaling messages are carried by the channel. In voice mode voice frames are carried by the channel, but the capability to inject signaling messages by occasionally dropping voice subframes exists. Frames containing inband signaling messages employ a unique word different from that used for frames containing only voice subframes.

Interstation signaling channels (GC-I and FES-I) are used to pass signaling information between the GC and each of the FESs. These channels operate at a rate of 9.6 to 64 kbit/s and are implemented using either the available 5 MHz Ku-band satellite capacity or terrestrial links. The LAP-F protocol will be employed on those links to ensure reliable transfer of variable length signaling and network management messages.

When a MET is idle (powered on and ready to receive a call) it will continuously receive an Outbound TDM channel in order to receive call announcements associated with incoming calls and obtain status information from bulletin board signaling units. Each MET will be capable of transmitting signaling information to the GC on any of the inbound random access channels or on any of the inbound TDMA channels associated with the outbound TDM channel

that it is receiving. During a call a MET will receive and transmit all signaling information via the In-Band signaling channels. No signaling information will be sent to a MET via the outbound TDM channel during a call. Any signaling messages from the GC to the MET will be sent to the MET via the FES through the GC-I and FES-C channels.

Each group controller supports at least one outbound TDM channel in each of its associated L-band beams. Each outbound TDM signaling channel is continuously transmitted and carries frequency assignments and networks status information from the GC to the METs. The outbound TDM channels are also used to poll idle METs to see if they can accept incoming calls. As this channel is the only way to signal information to a MET not engaged in communications, it must be as robust as possible under harsh fading and shadowing conditions.

Another key element in the MSS system is the need for the METs to be as inexpensive as possible. Towards this end, the outbound TDM channel will have the same rate and modulation as the communications channels. This will maximize the commonality of the receive chain of the MET for communications and signaling. Note that as the demodulation process is much more complex than the modulation process, the inbound random access and inbound TDMA channels do not really require this level of commonality with the communications channel.

The number of outbound TDM channels assigned to each set of signaling channels is determined by the traffic supported by the group controller in that L-band beam. Assignment of METs to outbound TDM channels is made based on a special identifier assigned to each MET as commissioning. This identifier is called the GC-S Selector Identifier code (GSI). The MET selects the outbound TDM channel to be used by dividing the GSI by the total number of outbound TDM channels available in the given beam. The number of TDM channels available is given in the BB of each TDM channel. The remainder of the four bit binary division process will form the number of the channel to be used. Each MET will receive only the outbound TDM channel assigned to it. This method allows METs in the same logical grouping to be assigned to the same outbound TDM channel as is needed for the Net Radio Service provided by the MSS System. It also allows the load on the outbound TDM channels to be redistributed quickly if a channel fails or a new channel is added.

The 120 ms frame length was chosen because it would support 6 messages per frame and correspond to the slot size requirement (>120 ms) of the inbound TDMA channel. This allows a direct correspondence between outbound TDM frames and inbound TDMA slots for the purposes of TDMA synchronization and scheduling responses to outbound messages. Eight flush bits are included at the end of each frame to allow the decoder to reset to a known state at the beginning of each frame. This allows more rapid reacquisition following channel fade events. The modulation scheme and transmission rate for this channel will be the same as for the transmission channel, namely QPSK modulation at a transmission rate of 6750 bps. Signaling units within each frame will be coded with a rate 3/4 constraint length K=7 convolutional code.

The outbound TDM superframe has a duration of 360 ms and is made up of three outbound TDM frames. The superframe duration is the basic time interval over which message repetitions are done. Repetitions are used to increase the reliability of outbound TDM signaling units. Messages can be repeated in consecutive superframes. Studies by AUS-

SAT have shown that L-band fade events typically have durations ranging between 10 ms and 100 ms (2). Because the 120 ms frame would not provide adequate separation between message repetitions, the 360 ms superframe is used to reduce the chance of losing two copies of a message during the same L-band fade event. This repetition method is similar to that used in the AUSSAT system. Different numbers of repetitions may be used for different message types to provide different levels of reliability. The number of repetitions used for a particular message type will be a part of the signaling protocols and can be varied by the system operator. In addition to message repetitions, interleaving will be used to protect against burst errors. The interleaving is provided over a TDM frame and provides improved performance in the presence of short burst errors.

The bulletin board is a set of signaling unit (SUs) that are periodically transmitted by the MCC on all outbound TDM channels. The bulletin board contains global information such as current network status, signaling channel frequencies and inbound random access channel congestion control parameters. Every MET processes the information in the bulletin board METs, on startup, and acquires the entire bulletin board before attempting to use the MSS system. At least one bulletin board SU is transmitted in every outbound TDM frame. Bulletin board SUs are also sent as "filler" SUs, i.e., sent when there are no other SUs pending on the outbound TDM channels. Bulletin board SUs do not occupy any fixed position in the outbound TDM frame.

Bulletin board SUs are grouped into pages of related SUs. Each Bulletin Board page has an update number associated with it, which will be sent with each SU of that page. This number will be incremented by the NCC whenever the information in that page is updated. METs are required to build a local data structure that contains the contents of the bulletin board. Whenever a change in update number is detected for any page, the MET will update the entire data structure for that page with the contents of the bulletin board SUs that follow.

The inbound TDMA channel is used by the METs to transmit responses to call announcement messages and for responses to other messages received on the outbound TDM channel. Each of the inbound TDMA channels is assigned to a particular outbound TDM channel. The number of inbound TDMA channel assigned to a particular outbound TDM channel depends on the traffic supported by that outbound TDM channel and is selectable by the network operator. The TDMA channel is divided into slots of 120 ms duration. Inbound messages consist of 96 bits before coding and 128 bits after rate 3/4 convolutional coding. The resulting burst will occupy 80 ms of the slot, allowing 40 ms of guard time.

This guard time arises due to the uncertainty in round trip transmission time between the satellite and a mobile terminal. Mobile terminals derive their inbound frame timing (for both the TDMA and random access channels) from the outbound TDM frames. Inbound TDMA slots have the same duration as an outbound TDM frame. At a MET each TDMA slot boundary occurs at an outbound TDM frame boundary. If MET A is nearer to the satellite than MET B, MET A will receive the outbound TDM channel sooner than MET B, where  $A_t$  corresponds to the difference in propagation times to the satellite for the two terminals. As a result, if both METs synchronize their transmit timing to their reception of the outbound TDM channel, MET B's responses to messages will take  $2A_t$  longer to reach the satellite than MET A's responses. As additional guard time of 1 symbol time also must be included to account for the  $\pm 1/2$  symbol synchronization uncertainty in the MET. This results in a total guard time requirement of  $2\Delta t + 1$  symbol time.

TDMA scheduling is done using a fixed relationship between outbound TDM channel time slots and inbound TDMA channels and slots. The response to a message received in the  $n$ th slot of the outbound TDM frame is transmitted on the  $n$ th TDMA channel assigned to that outbound TDM channel. The frequencies of the assigned inbound TDMA channels are contained in one of the bulletin board signaling units periodically transmitted in the outbound TDM channel. The response to an outbound message is transmitted in the TDMA time slot that begins 120 ms after the end of the TDM frame in which the outbound message was received. This should provide adequate time for message processing in the MET.

The inbound random access channel is used by the METs to transmit call requests to the GC. It is also used to carry other inbound messages for MET originated actions. The number of inbound random access channels assigned to a particular control group in a particular L-band beam depends on the traffic supported by that control group in that beam and is selectable by the network operator. To provide reasonable call setup times and call loss probabilities these channels are typically be operated at a throughput of approximately 25% or less. As the random access channel is operating at a relatively low efficiency, one of the prime goals in its design is that it be bandwidth efficient.

The frequencies used for the random access channels are transmitted in the bulletin board signal units. For each transmission, METs choose at random among the inbound signaling channels assigned to their control group. After transmitting a message, the MET waits a given amount of time for a response. If no response is received within this amount of time, the MET retransmits in a slot selected at random over some given number of slots. This procedure is repeated until either a response is received or a maximum number of transmissions is reached. The bursts on the random access channel are identical to those on the TDMA channel (i.e., modulation, coding, preamble, etc.).

The MET-GC Signaling Protocol (MGSP) procedures send signaling units between GCs and METs via the GC-S, MET-ST and MET-SR channels. This protocol encapsulates functions such as channel selection, channel access, slot timing, error recovery and congestion control. Higher layer functions, such as call processing, use the protocol for communicating among themselves between the METs and GCs.

The relationship of MGSP to other signaling layers in the GC and the MET is shown in FIG. 12. A transaction consists of a command message that is sent from an originating application to a destination application, to which the destination application replies with a response message. Each command and response consists of a signaling unit. The MGSP performs functions such as channel selection, error recovery using retransmission, and repetition of SUs to improve channel reliability. The MGSP at a MET also implements congestion control procedures for the MET-SR channels. Only one outstanding transaction exists between a MET and a GC in a given direction. However, two simultaneous transactions, one in each direction, are supported between a GC and a MET. MGSP also provides a only-way message service, that does not require a response from the receiver.

The improved call setup protocol used to establish a MET originated voice call is shown in FIG. 13. When a MET user initiates a call, the MET formats and transmits an access request message via a random access channel. This message includes the call type and the destination phone number. The

group controller chooses an FES to handle the call and sends frequency assignments to the MET via the TDM channel and to the FES via the interstation signaling channel. The FES frequency assignment also includes the call type, the destination phone number to allow the FES to complete the call, and an access security check field used to verify the MET's identity. The access security check field is generated by the group controller using the MET frequency assignment and the MET key which is known only to the MET and the group controller.

After the MET receives the frequency assignment, it transmits a scrambling vector message to the FES. This message contains the initial vector to be preloaded into the FES scrambler at the beginning of each voice channel frame. Letting the MET randomly pick this vector provides some degree of privacy on the Ku to L-band link. The scrambling vector message also contains an access security check field generated by the MET using its frequency assignment and its key. The FES compares this field with that received from the group controller to verify the identity of the MET. After receiving the scrambling vector message, the FES and the MET switch from call setup mode to voice frame mode and the FES completes the call to the terrestrial network user.

The improved protocol used for PSTN originated calls is shown in FIG. 14. When a call from a terrestrial network user arrives at an FES, the FES makes a channel request using interstation signaling. This request contains the phone number received from the terrestrial network user. The group controller determines the MET identity based on the phone number and transmits a call announcement via the TDM channel. The MET acknowledges this announcement via the TDMA channel. This exchange allows the group controller to verify that the MET is available before assigning bandwidth to the call. Frequency assignments are then made and the scrambling vector is transmitted by the MET. The call is then completed to the MET user.

MET to MET calls are set up using a double hop connection through an FES. These calls are set up by the group controller and the FES as a MET to PSTN call setup concatenated with a PSTN to MET call setup. As a result the METs require no additional call processing for MET to MET calls.

Advantageously, the MET combines three different features for the delivery and transmission of voice and data. These three features include: the ability to initiate and transmit a data call, the ability to initiate and transmit a facsimile digital call, and the ability to roam between satellite and terrestrial based wireless communication systems. The following documents, representing applicable transmission protocols, are hereby incorporated by reference: EIA/IS-41B Cellular Radio Telecommunications Inter-System Operations; EIA/TIA-553-1989 "Cellular System Mobile Station—Land Station Compatibility Standard"; EIA/TIA-557; EIA/IS-54B.

FIG. 15 is a diagram of a visitor registration sequence of the MET applicable to MET roaming situations. The Mobile Telephone Cellular Roaming Service (MTCR) supplements cellular service, providing access where there is no cellular coverage. The "home" Mobile Switching Center (MSC) of the multimode MET, as defined in EIA/IS-41B, is either the terrestrial cellular mobile carrier (CMC) system or the satellite network system. The MET registers as a "visitor" in either the satellite MSC or a terrestrial cellular system MSC per the requirements of EIA/IS-41B. The gateway provides automatic roaming for METs outside the range of terrestrial cellular coverage in accordance with EIA/IS-41B. METs are

identified with the same 10-digit telephone number in the terrestrial cellular and satellite networks.

In the idle state, a mobile unit monitors the cellular and satellite signaling channels. The normal cellular procedure is used for terrestrial calls as defined in EIA/TIA 557. Each MET uses the cellular terminal ESN (electronic serial number) and the telephone number for the purposes of identification and registration on the CMC. Upon power up, the MET registers per the requirements of FIG. 16. If unsuccessful, it registers in accordance with the secondary selection, if applicable. If the mobile is in the coverage area of selected preferential service, the MET will not attempt to register as a roamer in another system until the MET detects the absence of preferential coverage. At that time, the MET attempts to register on the secondary coverage system as a roamer.

If the MET is registered in a secondary coverage system as a roamer, and detects the availability of preferential coverage, it attempts to register (reregister) with the preferential system. However, once a call is established on the satellite system, it remains on the satellite system until completion.

Reregistration only occurs after a suitable time delay at the MET to avoid constantly switching between networks. For all reregistrations, a suitable time delay is defined as follows. The MET, upon the loss of a primary service (satellite or cellular) waits, for example, a nominal 6 seconds before attempting to register in the alternate service (cellular or satellite). If the primary service is recovered prior to the expiration of the 6 second delay, the mobile will not attempt reregistration. When registered on the alternate service, the MET will wait a nominal 6 seconds, and will then continuously monitor the availability of the primary service. When the primary service becomes satisfactorily available, the MET will attempt to return the registration to the primary service.

If the primary service is subsequently lost again, the MET will wait a nominal 15 seconds before attempting to register in the alternate service. If the primary service is recovered prior to the expiration of the 15 seconds delay, the mobile will not attempt reregistration. When registered on the alternate service, the MET will wait a nominal 15 seconds, and will continuously monitor the availability of the primary service. When the primary service becomes satisfactorily available, the MET will attempt to return the registration to the primary service.

If the primary service is subsequently lost again (a third or more times), the MET will wait a nominal 30 seconds before attempting to register in the alternate service. If the primary service is recovered prior to the expiration of the 30 second delay, the mobile will not attempt reregistration. When registered on the alternate service, the MET will wait a nominal 30 seconds and will then continuously monitor the availability of the primary service. When the primary service becomes satisfactorily available, the MET will attempt to return the registration to the primary service.

Once the MET has invoked any reregistration, a 5 minute timer will be started. The timer will be reset to 5 minutes for each reregistration. If the 5 minute timer expires, the reregistration delay will be set to a nominal 6 seconds and the cycle will start over again. If both services are lost, the MET will continuously monitor both services, and will attempt to register (reregister) on whichever service becomes satisfactorily available.

FIG. 17a is a basic block diagram of the functions of the mobile earth terminal including the digital terminal equipment functions for MET data calls. The calling procedures

for MET initiated data calls permit standard data terminal equipments (DTEs) connected to METs to place 2400 bps and 4800 bps data calls to appropriately equipped subscribers of the PSTN or members of private networks, similar to a data call by a standard modem. As discussed below, however, additional functions are required to effectuate the data call in the MET environment. The 2400 bps mode has a fall back rate of 1200 bps. The frame and data field formats for 1200 bps is identical to that for 2400 bps.

The AT command set is a set of commands commonly used for exchange of control information between DTEs and dial up modems. DTEs connected to the MET use a subset of the AT command set to send commands to the MET and receive responses from the MET. The message sequence shown in FIG. 17b is used to establish MET originated data calls. The protocol employed is specified in the event tree given in FIGS. 18-19. A data call is initiated by the transmission of an ATD command from the DTE to the MET. The ATD command contains the telephone number of the destination modem/DTE. The ATD command also contains the desired transmission speed and the character format to be used.

The message type field of the access request SU indicates that the call is a data call. Upon reception of the MET channel assignment SU, the MET transmits a scrambling vector SU to the FES via the MET-C channel. This message is continuously repeated until data frames are received from the FES. If no response is received after 5 seconds the MET ceases transmission and signals call failure to the user. The scrambling vector SU contains the initial scrambling vector to be used by the FES on the FES-C channel, the access security check field generated by the MET, and the desired character format and line speed for the connection.

Upon successful reception of the scrambling vector SUs, the FES will compare the access security check fields received from the GC and the MET and initiate call release if the fields are not identical. If the access security check fields are identical, the FES will seize a circuit into the PSTN and initiate establishment of the terrestrial portion of the connection. The FES will also switch to data mode and begin transmitting data frames to the MET. Upon reception of the data frames from the FES the MET switches from the call setup frame mode to the data frame mode and continuously transmits data frames to the FES with NULL SUs in the in-band signaling frames until a "connect" SU is received from the FES. For 1200/2400 bps data calls, the MET and FES transmit null SUs in the SU field.

Upon receiving data frames from the MET, the FES will begin transmitting ringing SUs to the MET in the inband signaling field of the data frames. Upon detection of the PSTN going off-hook, the FES will stop sending ringing SUs and will begin transmitting answer SUs to the MET in the in-band signaling field of the data frames. Upon completion of the handshake and bit rate selection procedures between the FES terrestrial modem and the PSTN user modem, the FES will stop transmitting answer SUs and will begin transmitting "Connect" SUs to the MET. Upon receiving a "Connect" SU from the FES, the MET continuously transmits "Connect Acknowledgment" SUs. Upon receiving a "Connect Acknowledgment" SU from the MET, the FES will cease transmitting connect SUs to the MET.

For data calls the DTE must be involved in the call release procedure. In all other respects the call release procedures for both MET and PSTN initiated data call release is the same as those specified for MET initiated calls. MET originated call release occurs when the DTE issues an ATH command to the MET. When PSTN initiated call release

occurs the MET issues a NO CARRIER indication to the DTE. The sequences for MET and PSTN initiated data call release are shown in FIGS. 20-21. The MET continuously transmits "On Hook" SUs until it receives an "On-Hook Acknowledgment" SU or until timers TM5 or TM7 expire.

The data field portion of the data call is used to transport asynchronous data characters as shown in FIG. 22. Each data character byte shall consist of either a 7-bit data character representation with a parity bit or an 8-bit character representation. All data characters are transmitted least significant bit first. If a 7-bit data character representation with a parity bits used, the least significant bit shall contain the parity bit. If a 7-bit data character representation without a variety bits used, the least significant bit contains a 0 bit. Valid data characters are transported in the first L data character bytes of the frame, where L is the value of the length parameter contained in the length indicator bytes. All other data character bytes preferably contain a 10101010 pattern.

The format of the length indicator bytes shall be as shown in FIG. 23. The length indicator bytes each contain a 6 bit length parameter that indicates the number of valid data character in the total frame. In addition the length indicator byte contains 2 parity bits used for error detection. The order of transmission of the bits in the length indicator byte is also as indicated in FIG. 24.

For PSTN-originated data calls, channel assignment is as specified for PSTN originated voice calls. The GC will determine that the call is a data call and will indicate this in the call type field of the call announcement and MET channel assignment.

Upon reception of the MET channel assignment SU the MET transmits a scrambling vector SU to the FES via the MET-C channel. This message is continuously repeated until a response is received from the FES. If no response is received after 5 seconds the MET ceases transmission and signal call failure to the user. Upon successful reception of the scrambling vector SUs, the FES will compare the access security check fields received from the GC and the MET and will initiate call release if the fields are not identical. If the access security check fields are identical, the FES will begin transmitting the ring command SU to the MET. Upon reception of the ring command SU from the FES, the MET signals the MET user either by generating an audible ringing sound or by sending a RING response to the DTE, sets Tm8 to 12 seconds and also transmits the ring command acknowledgment SU until the ATA command is issued by the MET DTE, or upon expiration of timer Tm8. Upon receiving the ring command acknowledgment from the MET, the FES will transmit a call setup complete SU to the GC to notify it that the channel has successfully been established, and will begin transmitting null signal units to the MET. If timer TM8 expires, the MET initiates a call release.

When the MET DTE issues the ATA command the MET switches to the data frame mode, stop Tm8, and set timer Tm9 to 20 seconds. Upon detection of the MET switching to data frame mode, the FES will switch to data frame mode and will signal off-hook to the PSTN. The FES will then complete the modem bit rate selection and handshake procedures with the PSTN user modem based on CCITT Recommendation V.22bis. Upon completion of the modem bit rate selection and handshake procedures, the FES will begin continuously transmitting a connect SU to the MET. The FES continues sending the connect SU until a connect acknowledge SU is received from the MET. Upon receiving the connect acknowledge SU, the FES ceases transmitting connect SUs.

Upon receiving the connect SU from the FES, the MET stops timer Tm9 and sends the connect acknowledge SU to the FES. The MET ceases transmitting connect acknowledgement SUs within 2 seconds of the time at which receipt of connect SUs ceases. If timer Tm9 expires, the MET initiates a call release.

FIG. 25 is a basic block diagram of the functions of the mobile earth terminal including the facsimile interface unit functions. Facsimile interface units (FIU) are installed in the Feeder Link Earth Stations (FES) and in the MET which communicate with each other by a digital communications channel established in the facsimile data mode. These units enable a terrestrial user's CCITT Group 3 facsimile terminal equipment (FTE) to be interconnected with a MET user's CCITT Group 3 FTE (or between two MET users) via the digital satellite system.

The FIUs perform two basic functions. First, they demodulate the facsimile voiceband signals in the FTE-to-satellite direction (and remodulate the baseband digital signals in the satellite-to-FTE direction). Second, they perform protocol conversions so that the facsimile protocols become compatible with the transport channel constraints of the basic service configuration. To perform these functions, the FIUs consist of several standard elements including Telephone Tone Generators and Detectors; a CCITT V.21 Modulator and Demodulator; and Control Logic for baseband message formatting, facsimile process control, facsimile protocol conversation, call establishment, call control, and call clearing.

The physical interface is preferably characterized using an RJ-11 connector, a 600 ohms signal impedance, a Line Supervision (Detection of Off-Hook and On-Hook), a Minus 24 volt, 30 ma nominal DC source for loop (supervisory) current. The interface preferably provides ringing voltage of 86 Vrms and support up to 5 ring loads, or provides a source over the linear range from 64 Vrms at 50 ms down to a minimum of 40 Vrms at 100 ma. The required generated signaling tones are:

- Congestion [480+620 Hz (0.25 sec's on and 0.25 sec's off)]
- Busy [480+620 Hz (0.5 sec's on and 0.5 sec's off)]
- Ring-back [440+480 Hz (1 sec on and 1 sec off)]
- Dial [Reference CCITT E.180:350+440 Hz (continuous)-10 Dbm0 nominally]

The FIUs transmit and receive digital signals to and from the satellite 2.4 kbit/ss Data channel in blocks of 288 bits as shown in FIG. 26, which illustrates the sub-field structure of the data channel. In addition, the FIU internally partitions each of the 288-bit data-field into 36, 8-bit data cells. The Digital Facsimile Protocol provides line-state indication by means of the following messages, carried as "line control packets", which are transmitted at full rate (i.e., 2.4 kbit/s) over the data channel. The coding is described below:

CodeLine state	
0001	Idle
0010	CED Connection
0100	Spare
0111	Binary Coded Signal Connection
1000	FIU Capabilities Control Packet
1011	Synchronizing Signal Connection
1101	Preamble Connection
1110	Message Connection

The coding is associated with the voiceband signal states as shown below:

IndicationLine State  
 Idle No signal on the telephone circuit

- CED Connection
- 2100 Hz Called Station Identification (CED) signal on the telephone circuit
- Binary Coded Sig. 300 bit/s (non-permeable) binary Connection
- 5 coded procedural signal on the telephone circuit
- Synch. Signal
- Modem synchronizing (or Connection
- 10 training signal on telephone circuit)
- Preamble Connection
- 300 bit/s binary coded preamble signal on the telephone circuit
- Message Connection
- 15 Facsimile message on the telephone circuit
- The special line state "FIU Capabilities Control Packet" is not associated with an analog line state but with inband signaling between FIUs.

Line control packets are generated whenever a line state transition occurs, and generally always precede the transmission of information (associated with the new line state) over the digital channel. The indication in the line control packet applies to all associated 8-bit data cells of the satellite channel that immediately follow it until a new line control packet is generated. Hence, these line control packets are used as headers of new information. All non-preamble signals of the 300 bit/s binary coded procedural signalling, which are specified in CCITT Recommendation T.30, are transferred to the re-modulating (distant) FIU in the form of a demodulated baseband digital data stream. A re-modulating (or modulating) FIU is defined as the FIU which is receiving data from the satellite channel for modulation and transmission to the customer FTE. A demodulating FIU is defined as the FIU which is receiving data from the customer FTE for demodulation and transmission to the satellite channel. During a call, an FIU will perform both modulating and demodulating functions, as the signal direction between the end-customer FTEs will change several times.

The facsimile message signal (including the TCF signal) is also transferred to the re-modulating FIU in the form of a demodulated digital data stream. Reception of the modem synchronizing signal on the telephone circuit is indicated by the demodulating FIU to the re-modulating FTU by transmitting the "Synchronizing Signal Connection" line control packet. The FIU at the modulating end generates a modem synchronizing signal according to this indication. Detection of the CED signal on the telephone circuit is indicated by the demodulating FIU to the re-modulating FIU by transmitting the "ICED Connection" line control packet. (The actual CED signal cannot be transferred to the re-modulating FIU since it is not digital by nature.)

The tonal signalling procedures defined in CCITT Recommendation T.30 are not generally accommodated by the Digital Facsimile Protocol. The Group 3 procedures recommended by CCITT are generally supported by the FIU. Therefore, the FIU is not required to detect the use of tonal signalling procedures. Eventually a Group 1 or Group 2 FTE should clear the call on the analog circuit when it does not receive proper responses from the FIU.

Line control packets are generated whenever a line state transition occurs, and generally always precede the transmission of information (associated with the new line state) over the digital channel. Because these packets are transmitted in-band over the 2.4 kbit/s data channel, they are generated by the demodulating FIU in the FTE-to-satellite direction and removed by the remodulating FIU in the satellite-to-FTE direction. The first bit of the line control

packet must be coincident with a data cell boundary. When generating line control packets these are constructed by utilization of 18 data calls as follows:

The first 9 data calls (72 bits) are comprised of nine repetitions of the "11111111" binary octet and are used as a line control preamble to indicated that the following 9 data cells contain line state transition information. The next 8 data cells (64 bits) are comprised of 16 repetitions of the appropriate 4-bit code for the new line state. The final data cell (8 bits) comprises the unique binary word "11000011" which is used to precisely align the user data associated with the new line state. The new line state indicated by a received line control packet does not become effective until the last bit of the line control packet has been received on the satellite channel. Consequently, since line control packets are 18 data cells long, a line control packet inserted into the satellite data stream effectively adds 60 ms to the length of the previous line state.

This is true for receipt of all line control packets except an "Idle" packet when it has been preceded by either a "Binary Coded Signal Connection" packet or a "Message Connection" packet. In either of those two cases, the "Idle" line control packet must be immediately processed (removed from the satellite data stream) when the first, rather than the last bit of the packet is received, thus avoiding a situation where 60 ms of invalid data would be modulated at either the V.21 or V.27ter mode. To accomplish this "early line control packet detection," the FIU must incorporate a look-ahead buffer between the satellite channel and the FIU software in which it can look ahead 60 ms into the received satellite data stream and identify a valid "Idle" line control packet while in the "Binary Coded Signal Connection" or "Message Connection" line state.

Since, in the special situations, the "Idle" line control packet is removed all at once (instead of removing it over the course of 18 data cell times), the look-ahead buffer will shrink in size as "Idle" line control packets are detected and removed. When the FIU switches from its "modulating" role to its "demodulating" role, the look-ahead buffer may be empty due to the removal of "Idle" line control packets. The buffer must already be filled with satellite data by the time an FIU switches from the "demodulating" role to the "modulating" role. This filling can take place when the FIU is likely to be receiving idle fill over the satellite when it is in the "demodulating" role.

Furthermore, the look-ahead buffer must accommodate two line control packets since, at most, there will be two transitions from "Binary Coded Signal Connection" or "Message Connection" line state to "Idle" line state during a single line turnaround of the half-duplex T.30 facsimile protocol. That is, the buffer must be about 288 bits in size. This will add, at most, 120 ms to the overall delay through the FIU.

The facsimile interface unit (FIU) interworks with a user's CCITT Group 3 facsimile terminal equipment (FTE) through a telephone circuits in accordance with CCITT Recommendation T.30, and with the FIU at the distant end through the satellite channel in accordance with the Digital Facsimile Protocol. To accomplish this, the FIU shall comprise the following standard circuit elements:

CCITT Recommend. V.27 ter [R-27] voice-band data modem;

CCITT Recommendation V.21 [R-28] voice-band data modem;

2100 Hz tone generator and detractor;

1100 Hz interrupted tone generator and detector;

processor/controller; and

elastic buffer, multiplexer/demultiplexer, and interface with the satellite channel unit.

After the FIUs have been switched-in by the FES or the MET in a remote-originated mode (FTE at the opposite FIU has originated the call), the FIU generates the CNG signal (a 1100 Hz interrupted tone) and transmits it to the called user. The CNG signal is terminated following the detection of either the CED signal or a 300 bit/s binary coded procedural signal on the incoming telephone circuit in accordance with the procedures defined in CCITT Recommendation V.25 [R-29]. The characteristics of the CNG signal comply with the relevant requirements specified in CCITT Recommendation T.30.

The called FTE may transmit the CED signal following the connection of the telephone circuit at the called end. The called FIU shall detect the onset and termination of the CED signal on the telephone circuit and shall inform the calling FIU of this event by inserting the "CED Connection" line control packet in the satellite channel. The CED signal detector response threshold and times shall be in accordance to CCITT Recommendations T.4, T.30, and V.25 [R.29]. The insertion of the "ICED Connection" line control packet in the data channel occurs in the first data-cell to be transmitted after the CED detector output has changed from OFF to ON.

The "ICED Connection" line state is changed to "Idle" by transmissions of the "Idle" line control packet in the data channel as soon as the ON-to-OFF transition of the CED signal is detected and a data-cell boundary becomes available, but subject to the restriction that a "Idle" signal gap of  $75 \pm 20$  ms must be inserted (i.e.  $22 \pm 6$  data cells) between the CED signal termination and the following signal (DIS) which is encoded according to the V.21 modulation scheme. That is, there must be at least one data cell between the "Idle" line control packet and the subsequent "Preamble Connection" line control packet (since transmission of the "Preamble Connection" packet contributes 60 ms to the length of the "Idle" line state). It is the responsibility of the FIU to be aware of the (possibly different) on-to-off and off-to-on signal detect times for CED and V.21 Preamble and adjust the generated satellite line control packets accordingly so as to insure a  $75 \pm 20$  ms idle time between different signals.

The called FTE transmits the CED signal following the connection of the telephone circuit at the called end. The called FIU detects the onset and termination of the CED signal on the telephone circuit and informs the calling FIU of this event by inserting the "ICED Connection" line control packet in the satellite channel. The CED signal detector response threshold and times are in accordance to CCITT Recommendations T.4, T.30, and V.25 [R-29]. The insertion of the "CED Connection" line control packet in the data channel occurs in the first data-cell to be transmitted after the CED detector output has changed from OFF to ON.

The "CED Connection" line state shall be changed to "Idle" by transmission of the "Idle" line control packet in the data channel as soon as the ON-to-OFF transition of the CED signal is detected and a data-cell boundary becomes available, but subject to the restriction that a "Idle" signal gap of  $75 \pm 20$  ms must be inserted (i.e.  $22 \pm 6$  data cells) between the CED signal termination and the following signal (DIS) which is encoded according to the V.21 modulation scheme. That is, there must be at least one data cell between the "Idle" line control packet and the subsequent "Preamble Connection" line control packet (since transmission of the "Preamble Connection" packet contributes 60 ms to the length of the "Idle" line state). The FIU detects the (possibly different) on-to-off and off-to-on signal detect

times for CED and V.21 Preamble and adjusts the generated satellite line control packets accordingly so as to insure a  $75\pm 20$  ms idle time between different signals.

A CED signal is generated by the called FTE after the telephone circuit has been connected between the called FIU and the called FTE. The onset and termination of the CED signal on the telephone circuit are detected by the called (demodulating) FIU and signalled to the calling (re-modulating) FIU by means of line control packets. The calling FIU shall generate a CED signal (2100 Hz tone) and shall transmit it to the calling FTE when the line control packet indicates "CED Connection". The OFF-to-ON instruction to the tone generator shall occur only after the entire "CED Connection" line control packet has been received.

The ON-to-OFF instruction to the tone generator occurs when a new line control packet has been detected by the called FIU. Ideally, the "Idle" line control packet will be received following the "CED Connection" packet, but errors on the satellite channel may corrupt the "Idle" packet so that the "Preamble Connection" packet may be the next one detected. The characteristics of the generated 2100 Hz tone shall comply with the relevant requirements for the CED signal specified in CCITT Recommendations T.30, T.4, and V.25.

The FIU receives and demodulates the binary coded procedural signals which are defined in CCITT Recommendation T.30 and which appear on the incoming telephone circuit. The binary coded procedural signals (except the TCF signal) are modulated at 300 bit/s in accordance with the CCITT Recommendation V.21 modulation system and are preceded by the preamble (sequence of repeated flags) specified in CCITT Recommendation T.30. The TCF signal is modulated at 2.4 kbit/s in accordance with CCITT Recommendation V.27 ter and is preceded by the modem synchronizing signal. The data is transmitted over the satellite channel in the same order as received over the telephone circuit (i.e., the first bit received over the telephone circuit by the demodulating FIU is the first bit to be sent over the satellite channel to the re-modulating FIU).

The non-preamble portion of the V.21 modulated 300 bit/s binary coded procedural signal is defined as the portion of this signal which begins with the first non-Flag octet and ends with the last Flag received after the last HDLC frame. The preamble portion of the 300 bit/s binary coded procedural signal is defined as the portion of the V.21 modulated signal which begins with the first Flag and ends with the last Flag preceding the non-preamble portion (i.e. ends with the Flag preceding the first non-Flag octet of the binary coded information field). This definition is illustrated in FIG. 27.

The demodulated data stream of the non-preamble portion of the 300 bit/s binary coded procedural signal is transmitted to the re-modulating FIU regardless of the error state of the signal. The binary coded Address, Control, and HDLC information fields of the demodulated data (with the exception of the NEF, DIS, and DTC signals) are not generally manipulated by the demodulation process and the FCS field indicates an error condition, the regenerated FCS sequence must be such that it will result in an error condition being detected by the distant FTE, assuming subsequent error-free transmission. Transmission of the data shall be immediately preceded by the transmission of the "Binary Coded Signal Connection" line control packet.

When the demodulating FIU manipulates the DIS, DTC and DCS signals in the manner described in the preceding paragraphs, a new Frame Checking Sequence (FCS) must be computed. However, if the original (prior to manipulation)

signal indicates an FCS error, the sequence computed must be such that it will result in an error condition being detected by the distant FTE assuming subsequent error-free transmission. The demodulated, non-preamble data stream of the 300 bit/s signal is transmitted to the re-modulating FIU over the satellite channel, preceded by the "Binary Coded Sequence Connection" line control packet. The line control packet is delayed by the same amount as that introduced in the preamble in paragraph 10 above and is further aligned to make the first bit of the line control packet coincident with the first bit of a data cell. When reception of the 300 bit/s signal ceases, an "Idle" line control packet shall be inserted in the satellite channel starting at the next available data cell. The response time for the Synchronizing/TCF signal detection is in accordance to CCITT Recommendations T.4, and V.27ter.

The onset of the synchronizing portion of the synchronizing/TCF signal is signalled to the distant FIU by transmitting the "Synchronizing Signal Connection" line control packet. The transmission of the "Synchronizing Signal Connection" line control packet, signifying the transition from the "Idle" to the "Synchronizing Signal Connection" line state, occurs in the first data cell of the satellite data channel after a period of  $75\pm 20$  ms of idle activity has been transmitted over the satellite channel following the end of the previous (DCS) signal which was originally encoded according to the V.21 modulation scheme. That is, there must be at least one data cell between the "Idle" line control packet and the subsequent "Synchronizing Signal Connection" line control packet (since transmission of the "Synchronizing Signal Connection" packet contributes 60 ms to the length of the "Idle" line state. The FIU detects the (possibly different) on-to-off and off-to-on signal detect times for V.27 ter and V.21 and adjusts the generated satellite line control packets accordingly so as to insure a  $75\pm 20$  ms idle time between different signals.

When the line control packet indicate "Synchronizing Signal Connection", the data stream sent to the distant FIU includes a binary all "zero" sequence irrespective of the demodulated sequence. The "Synchronizing Signal Connection" line state continues until local V.27ter modem training is complete and the first bit of TCF data is demodulated by the local V.27ter modem. The signal activity detector does not detect Segment 2 of the V.27ter training sequence ("No transmitted energy") as the end of the modem Turn-On sequence. Thus, the Synchronizing Signal Connection line state will apply for at least 225 ms (regardless of the signal activity detector output state).

The demodulated and unscrambled TCF signal (originally a series of binary "zeros") is transmitted to the re-modulating FIU over the satellite channel, preceded by transmitting the "Message Connection" line control packet. To compensate for the possibility that the demodulating V.27ter modem interprets the end of the modem Turn-On sequence as TCF data, the FIU insures that the first 6 data cells (48 bits) of the TCF data transmitted over the satellite consist of binary "zeros", no matter what was actually demodulated by the V.27ter modem. The "Message Connection" line control packet and subsequent TCF data is delayed by the same amount as that introduced to the "Synchronizing Signal Connection" line control packet defined in paragraph 17 above, and is further aligned to make the first bit of the line control packet coincident with the first bit of the data cell.

The end of the TCF signal is determined by the FIU, and the tail of the signal is discarded if the number of bits is insufficient to fill the data cell. An "Idle" line control packet shall then be transmitted to the distant FIU in the following data cell.

The re-modulating FIU receives the data stream for the 300 bit/s binary coded procedural signals or the TCF signals (preceded by the "Binary Coded Signal Connection" or "Message Connection" line control packet, respectively) which are transmitted over the satellite by the demodulating FIU. The re-modulating FIU generates the voice-band data signals for the non-preamble portions of the binary coded procedural signals based on the data stream and the relevant line control packet, and transmits them to the FTE on the outgoing telephone circuit. In generating the modulated signals, no manipulation of the data is performed by the re-modulating FIU. If a new Frame Checking Sequence (FCS) is regenerated, and the original signal indicates an FCS error, the sequence computed must be such that it will result in an error condition being detected by the FTE, assuming subsequent error-free transmission.

The modulation applied to the data which have been preceded by the "Binary Coded Signal Connection" line control packet are at 300 bit/s and in accordance with the CCITT Recommendation V.21 modulation system (as specified in CCITT Recommendation T.30). The entire data, after removal of the line control packet, are transmitted to the FTE. The transmission of the 300 bit/s modulated binary coded signal preamble commences immediately after reception of a valid "Preamble Connection" line control packet and continues for as long as no new line state transition in the form of a valid line control packet is received. The Demodulating FIU makes sure that there is at least a  $75\pm 20$  ms gap between the "Preamble Connection" line state and the preceding line state. The re-modulating FIU must insure that the length of the "Idle" line state indicated on the satellite is correctly reproduced on the analog circuit. If, due to channel errors, the "Preamble Connection" line control packet was not preceded by an "Idle" packet, then the re-modulating FIU must insure that there is  $75\pm 20$  ms of idle analog line state before the flag sequence begins.

The transmission of the non-preamble 300 bit/s modulated binary coded (non-preamble procedural signals is initiated following the recognition of a line state change from "Preamble Connection" to "Binary Coded Signal Connection" signalled by the reception of a valid "Binary Coded Signal Connection" line control packet from the satellite data channel. The transmission of the non-preamble portion of the 300 bit/s modulated binary coded procedural signals follow the termination of the preamble with no interruption of signal energy on the outgoing telephone circuit. Furthermore, in order to preserve the octet integrity of the preamble being transmitted the 300 bit/s modulated binary coded procedural signals may additionally be delayed by a period of up to 8 data cells.

The transmission of the non-preamble 300 bit/s modulated signals continues until a valid "Idle" line control packet is received from the satellite channel. The FIU "looks ahead" in the received satellite data stream to identify the "Idle" line control packet as soon as its first bit has been received. The "Idle" line control packet, once so identified, will be immediately removed from the satellite data stream and will not contribute an additional 60 ms of time to the existing "Binary Coded Signal Connection" analog line state. In generating the TCF signal, the modulation shall be in accordance with CCITT Recommendation V.27ter.

When the most recently received line control packet indicates "Synchronizing Signal Connection", a modem synchronizing signal (the long sequence with protection against talker echo as specified in CCITT Recommendation V.27 ter) shall be generated by the re-modulating FIU. Transmission of the modem synchronizing signal is initiated

only after the line state change from "Idle" to "Synchronizing Signal Connection" has been detected by the reception of a valid "Synchronizing Signal Connection" line control packet. If the Synchronizing Signal has been preceded by a signal encoded according to the V.21 modulation scheme in the same direction of transmission (i.e. DCS), the demodulating FIU has made sure that the duration of the "Idle" line state between the last flag of the "DCS" message and the start of the "Synchronizing Signal Connection" line state is at least  $75\pm 20$  ms. The re-modulating FIU must insure that the duration of this "Idle" line state is accurately reproduced on the analog circuit. If, due to channel errors, the "Synchronizing Signal Connection" line control packet was not preceded by an "Idle" packet, then the re-modulating FIU insures that there is  $75\pm 20$  ms of idle analog line state before the flag sequence begins.

The synchronizing signal is followed, without an interruption of signal energy, by a signal modulated by the received TCF data (after removal of the "Message Connection" line control packet which will take an additional 60 ms). The received data is delayed as appropriate, to allow the first effective bit of data preceded by the "Message Connection" indication to coincide with the first bit which follows the synchronizing signal in the modulated signal. Ideally, the FIU will insure that data consisting of binary "zeros" is modulated in the event that v.27ter modem training completes before the "Message Connection" line control packet is received over the satellite. This situation could occur because of the tolerance allowed in V.27ter for the modem Turn-On sequence. Once the "Message Connection" line control packet is received, TCF data is modulated without modification by the FIU.

The TCF signal is almost immediately terminated upon reception of a valid "Idle" line control packet from the satellite channel. The FIU "looks ahead" in the received satellite data stream to identify the "Idle" line control packet as soon as its first bit has been received. The "Idle" line control packet, once so identified, will be almost immediately removed from the satellite data stream and will not contribute an additional 60 ms of time to the existing "Message Connection" analog line state.

The demodulating FIU receives and demodulates facsimile message signals modulated at 2400 bit/s using the CCITT Recommendation V.27 ter modulation system, as defined in CCITT Recommendation T.4. Each transmission of a message is preceded by the modem synchronizing signal specified in the CCITT V.27 ter. The onset of the synchronizing signal portion of the synchronizing facsimile message signal on the incoming telephone circuit is detected by the demodulating FIU and signalled to the re-modulating FIU by transmitting the "Synchronizing Signal Connection" line control packet over the satellite data channel in the first available data cell.

When CCITT V.27ter modem training has completed, the demodulating FIU inserts a "Message Connection" line control packet in the satellite data stream as soon as the first bit of valid demodulated data is available. Transmission of the demodulated data over the satellite is preferably in the same bit order as it was received on the analog circuit. The demodulated facsimile message is not generally manipulated in any way by the demodulating FIU. The tail of the facsimile message signal is detected by the demodulating FIU. The "Idle" line control packet is then transmitted to the re-modulating FIU. The "Idle" line control packet is transmitted to the re-modulating FIU in the data cell following the last bit of the last HDLC frame containing the last bit message data. If insufficient data is demodulated to fill a



complete satellite data cell, it will be padded with binary "zeroes" in order reach a data cell boundary.

The re-modulating FIU receives the facsimile message data stream which is transmitted over the satellite channel by the demodulating FIU, preceded by a "Message Connection" line control packet. When the most recently received line control packet indicates "Synchronizing Signal Connection" the long modem synchronizing sequence with protection against talker echo specified in CCITT Recommendation V.27ter is generated by the re-modulating FIU. The re-modulating FIU generates a voice-band data signal for the facsimile message signal, based on the received data stream, and transmits it to the FTE using 2.5 kbit/s modulation in accordance with CCITT Recommendation V.27ter.

The synchronizing signal is followed, without an interruption of signal energy, by a signal modulated by the received data, which is introduced by the "Message Connection" line control packet. Modulation of this data may be delayed to allow the first bit of data to coincide with the first bit which follows the modem synchronizing signal. It may also happen that local modem V.27ter training takes less time than that experienced at the demodulating FIU, as indicated by the local V.27ter modem completing its synchronizing phase before the arrival of the "Message Connection" line control packet. In this case, the FIU insures that binary data consisting of all "ones" should be inserted in the modulated data stream as fill until the arrival of the "Message Connection" line control packet. Then, insertion of fill will cease and the relevant data cells received over the satellite will be modulated on the analog circuit starting with the next available bit position in the modulated data stream.

The Message signal is almost immediately terminated on completion of the last bit of data as indicated by receipt of the "Idle" line control packet. The FIU "looks ahead" in the received satellite data stream to identify the "Idle" line control packet as soon as its first bit has been received. The "Idle" line control packet, once so identified, will be immediately removed from the satellite data stream and will not contribute an additional 60 ms of time to the existing "Message Connection" analog line state.

The FIUs, in the course of performing the processing tasks (e.g. signal detection, elastic buffering, signal buffering, line control packet generation and "look ahead") may introduce additional delays along the signal path from one FTE to another. The total throughout delay introduced by each FIU is implementation dependent but must not be greater than 1 second end-to-end. That is, the sum of the delay through the originating FIU plus the delay through the destination FIU must not exceed this value in either direction of data flow. This figure includes delays associated with the modulator and demodulator, the FIU itself and the FIU-to-modem interface. It does not include satellite transmission delay or delay through the PSTN network.

Delays due to satellite transmission and PSTN transmission should not exceed 0.5 seconds. This may require the selection of low-delay PSTN connections at the FES. The total delay, therefore, between FTEs should not exceed 1.5 seconds in either direction of data flow.

When the FES detects that a facsimile call is in progress, it will "switch-in" the FES FIU and signal to it whether this is a fixed or mobile-originated call. When the FES FIU has been switched-in with a fixed-originated call, it may receive a CNG tone from the FTE but this is ignored. It may also eventually receive a V.21 message from the FTE containing a DCN frame in the event that the FTE times out while waiting for a message from the MET FTE. Primarily, the FES FIU will be awaiting a signal from the MET FTU.

When the FES FIU has been switched-in with a mobile-originated call, it will start generating CNG tone on the analog circuit to the FTE. It will also be prepared to detect either CED tone or the onset of V.21 preamble. In either case, it will cease generation of the CNG tone as soon as either of these two signals has been detected.

The FES will "switch-out" the FES FIU when it detects that the satellite or PSTN call has cleared. The FIU will immediately cease operations both on the satellite and analog connections. Since there may be significant buffering of satellite or analog data both inside and outside the FIU, the FES will delay implementing the switch-out operation until it is certain that all buffered data has been delivered to the appropriate channel (and thus to either the MET or the analog FTE).

When the MET detects that a facsimile call is in progress, it will "switch-in" the MET FIU and signal to it whether this is a fixed or mobile-originated call. When the MET FIU has been switched-in with a mobile-originated call, it may receive a CNG tone from the FTE but this is ignored. It may also eventually receive a V.212 message from the FTE containing a DCN frame in the event that the FTE times out while waiting for a message from the FES FTE. Primarily the MET FIU will be awaiting a signal from the FES FIU. When the MET FIU has been switched-in with a fixed-originated call, it will start generating CNG tone on the analog circuit to the FTE. It will also be prepared to detect either CED tone or the onset of V.21 preamble. In either case, it will cease generation of the CNG tone as soon as either of these two signals has been detected.

The mobile communication system provides for fraud detection and user validation in a manner fully explained in the aforementioned related application Ser. No. 08/565,036. Reference is made to that application for a detailed description.

The improved NOC functional architecture is shown in the block diagram of FIG. 28. The NOC collects information pertaining to the utilization of resources and distributes information to appropriate destinations such as CMIS and NE/SE. The NOC is involved in network security to prevent unauthorized use. The blocks shown in the figure broadly represent the functions that the NOC performs or oversees. The network management is a framework for the NOC basic functions. The configuration management implements and allocates resources in cooperation with plans formulated with NE/SE. The operator interface serves a fault management function. Problems in the system are isolated and reported to give operations personnel the ability to see when problems occur and react to them. The operator interface is a man-machine interface (MMI) to present alarms and events to the operators. Information as to system configuration is also made available. Call records management serves as an accounting functionality. This function accepts MET registration records and other information sent by external entities for storage in appropriate NOC database tables. Usage data sent by the individual GCs and FESs are assembled into Call Records. Data management serves as a data base repository for transmission and receipt of information gathered by the other components of the network operations center.

FIGS. 29A-29C set forth the NOC architecture in more detail, the elements shown corresponding to the blocks of FIG. 28. As shown in FIG. 29A, the network management block contains Polycenter Processes modules that serve alarm manager, exporter, historian and operator control functions. The historian records performance of the network over time, collecting at suitable intervals statistics regarding

resource utilization, calls in progress. The management information repository (MIR) server interfaces with the exporter. Network update requests are received from the router. When transactions come in from NE/SE or CMIS, they need to be distributed to different parts of the system. Updates are distributed to the MIR server so that it can update the internal data base. After all elements of the system are set up, network updates are communicated back to the router for network implementation. Exporter transmits collections of information, including performance traffic data, to the database in the data management block.

The alarm rule manager sets thresholds for adverse conditions and executes set up procedures for the event management block. For example, if customer service center sends out a commissioning request and the commissioning fails, an alarm is generated and the NOC sends a message to CMIS describing the failure and the cause of the failure. The watchdog looks for events, such as the system disk becoming fully utilized and other fault conditions, and sends an alarm to NMS to operator screen. The performance data collector samples resource utilization, collects statistics and provides feedback. NOC process control is involved with custom processes such as NOC startup and shutdown.

Configuration updates are received by the configuration management block, shown in FIG. 29A. A routing table is used to distribute messages to the appropriate components of the NOC.

The data management block, illustrated in FIG. 29B, includes servers to interface with the NOC main data base (DB). The RTR router receives RTR requests from either satellite resource manager or configuration management. The NOC configuration DB server decides from polling NOC components whether the request for update is to be accepted. If so, the NOC data base (DB) is updated and confirmation is sent to other components to update local data bases. The request is basically distributed to all other components to vote on the appropriateness of the requested change. For each transaction there is a specific set of data bases that are to be updated. DC Comm exports information from the database to NE/SE and CMIS. As read transactions do not need to go through this voting to update process, accessing for reading is easily available to any of the system components. Performance data, collected in the network management collector, previously described, is periodically exported directly to the data management DB, as no updating of other module databases is needed. Such data is not related to the overall configuration.

The call records management block is shown in FIG. 29C. The functionality of this component accounts for customer usage to enable billing preparation by the configuration management information system (CMIS). Call detail records (CDRs) relating nonsatellite usage are received from the gateway switch (GWS) and call performance records (CPRs), or call usage records (CURs), relating satellite usage are received from the group controller (GC). These records are logged into files at the GWS and CUR/NRPR servers to be forwarded to CMIS and saved as backup in the data base. The call trace router sends RTR requests for call tracing and trapping to and from the GC. Call tracing requests are sent to the trace operator, shown in the operator interface block of FIG. 29C. Call trace information is received by the call trace router from the trace operator.

The operator interface includes the session manager. After logging in to the session manager, each of the functions represented by the other blocks within the operator interface block is available. When the system is started or restarted, the encryption/decryption code is established. The MT ASK

(Access Security Key) block, essentially a separate data base, contains specific keys specific to each telephone and is checked in real time for each call. The mobile telephone (MT) key is set up when the new MT is added to the system. MT ASK is also used for storing CMIS and GC encryption keys used for encrypting request transactions. The operator message (op. Msg.) block is an interface for E-mail. Resource allocation MMI permits the NOC operator to modify the system for day to day operations, such as taking resources off line or on line. The DB access permits the operator to read the data base DB. Bulletin Board records containing transmit and receive frequency information about the METs are available to the operator from the Site Manager location.

The event management block, involved with fault management, is shown in FIG. 29B. All messages are received in the event logger, logged to a file, sent to a printer and displayed at the NOC MMI. Where necessary, files are forwarded to external organizations such as CMIS or NE/SE. CGS (communications ground segment) event data are sent to the CGS event sink. The COTS (Commercial off the shelf) software sink receives other events, such as VMS events. The watchdog event sink receives events from the watchdog block in the network management block, described above. The operator communication (OPCOM) generator converts VMS events into a common format.

FIG. 30 represents a NOC data flow diagram, depicting the NOC top-level CSCs and the interfaces between them. A typical transaction in which the NOC would be involved is when a new customer is added to the system. CMIS provides the new customer information to the NOC through the configuration management block. The configuration manager determines that the customer is not a satellite resource and distributes update requests through the RTR to databases that must be updated with the new MET record. Data management will receive the update request for the NOC DB database. The NOC configuration DB server receives the request from RTR and votes on it and waits for RTR to return positive responses from the other data bases. At such time all involved data bases are updated. An event will be generated indicating that a new customer has been added successfully. The event is sent to the CGS event sink in data management to be displayed at the operator console in network management. The event is logged to file in the data management data base by event management and printed. A printed copy is forwarded through the external organization link to CMIS so that the customer service representative knows that the transaction has succeeded.

Although a number of arrangements of the invention have been mentioned by way of example, it is not intended that the invention be limited thereto. Accordingly, the invention should be considered to include any and all configuration, modifications, variations, combinations or equivalent arrangements falling within the scope of the following claims.

#### GLOSSARY

A Availability  
 AAC Airline Administrative Communications  
 AARM Access Authentication Request  
 ABH Average Busy Hour  
 AC Alternating Current  
 ACU Access Channel Unit  
 ACU Antenna Control Unit  
 AD Attribute Dictionary  
 AFC Automatic Frequency Control  
 AFS Antenna/Front-end Subsystem

AGC Automatic Gain Control  
 AIOD Automatic Number Identification Outward Dialing  
 AMI Alternative Mark Inversion  
 AMPS North American Analog and Digital Cellular Networks  
 AMSC American Mobile Satellite Corporation  
 AMS(R)S Aeronautical Mobile Satellite (Route) Service  
 AMSS(R) Aeronautical Mobile Satellite Services  
 ANI Automatic Number Identification  
 ANSI American National Standards Institute  
 ANT Antenna  
 AOC Aircraft Operational Communications  
 APC Airline Passenger Communications  
 API Applications Program Interface  
 AR Automatic Roaming  
 ASK Access Security Key  
 ASN.1 Abstract Syntax Notation One  
 AT Command set for a DTE to communicate with asynchronous host  
 ATC Air Traffic Control  
 AVD Alternate Voice/Data Calls  
 AWGN Additive White Gaussian Noise  
 AZ Azimuth  
 B8ZS Bipolar with 8 Zeros Substitution  
 BB Bulletin Board  
 BBS Bulletin Board Service  
 BER Bit Error Rate  
 BERT Bit Error Rate Tester  
 BID Beam Identifier Code  
 BIT Built In Test  
 BITE Built-In Test Equipment  
 BPS Bits Per Second  
 BS Base Station  
 BSPU Baseband Signaling Processing Unit  
 BSS Base Station Switch  
 C/No Carrier to Noise Power Density Ratio  
 CAC Channel Access and Control  
 CAF Call Failure Message  
 CCCS Command, Control, and Communications Subsystem  
 CCIR Consultative Committee International de Radio  
 CCITT Consultative Committee International Telegraph and Telephone  
 CCU Communications Channel Unit  
 CD Call Delivery  
 CDR Call Detail Record  
 CDR Critical Design Review  
 CDRL Contract Data Requirements List  
 CE Common Equipment  
 CG Control Group  
 CGID Control Group Identification Number  
 CGS Communications Ground Segment  
 CHA Channel Assignment Message  
 CHREL Channel Release Message  
 CHREQ Channel Request Message  
 CI Configuration Item  
 CIBER Cellular Intercarrier Billing Exchange Roamer  
 CIC Carrier Identification Code  
 CM Configuration Management  
 CMIP Common Management Information System  
 CMIS Configuration Management Information System  
 CMIS Customer Management Information System  
 COTS Commercial off-the-Shelf  
 CP Circuit Pool  
 CPD Call Processing Demonstration  
 CPS Circuit Pool Segment  
 CPU Central Processing Unit  
 C/PV Commissioning/Performance Verification

CRC Cyclic Redundancy Check  
 CS Communications System  
 CSC Computer Software Component  
 CSCI Computer Software Configuration Item  
 5 CSDT Channel Switchover Detection Time  
 CSF Critical System Functionality  
 CSMA/CD  
 Carrier Sense Multiple Access with Collision Detection  
 CSMP Circuit Switch Management Processor CSMPCS  
 10 Circuit Switch Management Data Processor Equipment Communications System  
 CSPU Channel Signal Processing Unit  
 CSR CAC Statistics Request CSREQ  
 Call Status Reply Message CSREQ  
 15 Call Status Request Message  
 CSU Computer Software Unit  
 CSUG Computer Software Unit Group  
 CTB Customer Test Bed  
 CTN Cellular Telephone Network  
 20 CTN Cellular Terrestrial Network  
 CTNI Cellular Telephone Network Interface  
 CU Channel Unit  
 CUD Call User Data  
 CUG Closed User Group  
 25 CUP Channel Unit Pool  
 CUS Channel Unit Subsystem  
 CVR Cellular Visitor Registration  
 CVRACK  
 Cellular Visitor Registration Acknowledge  
 30 CW Carrier Wave  
 CWCHA Call Waiting Channel Assignment Message  
 DAMA Demand Assignment Multiple Access  
 db Database  
 dbc Decibel Relative to Carrier  
 35 dB decibels  
 dBi dB Relative to Isotropic  
 dBm dB relative to 1 milli watt  
 dBW decibels relative to 1 watt  
 D bit 'Data Configuration' bit in X.25  
 40 DBMS DataBase Management System  
 dBw dB Relative to 1 Watt  
 DC Direct Current  
 DCE Data Circuit Terminating Equipment  
 DCE Data Communications Equipment  
 45 DCL Digital Command Language  
 DCN Down CoNverter  
 DCR# Document Control Release #  
 DCU Data Channel Unit  
 DD Design Document  
 50 DDCMP Digital Data Communications Message Protocol  
 DDS Direct Digital Synthesis  
 DECMCC Digital's Network Management System  
 DEQPSK Differential Encoded Quadrature Phase Shift Keying  
 55 DET Data Equipment Terminal  
 DFD Data Flow Diagram  
 DH Data Hub  
 DH-D Outbound Time Division Multiplex Channel from Data Hub to Mobile Terminal  
 60 DHP Data Hub Processor  
 DHSI DH-D Selector Identification Code  
 DID Direct Inward Dialing  
 DIDs Data Item Descriptions  
 DME Dial-Up Modem Emulation  
 65 DMQ DEC Message Queue  
 DMS Digital Multiplex System  
 DN Directory Number

DNS Digital Name Service  
 DOC Canadian Department Of Communications  
 DOD Direct Outward Dialing  
 DPSK Differential Phase Shift Keying  
 DQPSK Differentially Encoded Quadrature Phase Shift Keying 5  
 DSO Digital Service Level Zero (single 64K b/s channel)  
 DS 1 Digital Service Level One (twenty four voice channels)  
 DSP Digital Signal Processing  
 DSSS 1 Digital Subscriber Signaling System 1  
 DTC Digital Trunk Controller  
 DTE Data Terminal Equipment  
 DTE Data Terminal Element  
 DTMF Dual Tone Multiple Frequency  
 DVSI Digital Voice Systems, Inc.  
 Eb/No Bit Energy to Noise Power Density Ratio  
 ECN Engineering Change Notice  
 EFD EF Data, Inc.  
 EFTIN  
     Encrypted Forward Terminal Identification Number  
 E-I Exchange-Interexchange  
 EIA Electronic Industries Association  
 EICD Element Interface Control Document  
 EIE External Interface Equipment  
 EIRP Equivalent Isotropic Radiated Power  
 E1 Elevation  
 EMC ElectroMagnetic Compatibility  
 EMI ElectroMagnetic Interference  
 eng engineer or engineering  
 EO End Office  
 EO External Organizations  
 EOD End of Data  
 ESN Electronic Serial Number  
 FAX Facsimile  
 FCA Functional Configuration Audit  
 FCC Federal Communications Commission  
 FCS Fading Channel Simulator  
 FDMA FEC Forward Error Correction  
 FES Feederlink Earth Station  
 FES-C Inbound Communication channel from Feederlink Earth Station to Mobile Terminal  
 FES-I Interstation signaling channel from Feederlink Earth Station to Group Controller  
 FES/MT Feederlink Earth Station/Mobile Terminal  
 FES-RE Feederlink Earth Station-Radio Frequency Equipment  
 FES-TE Feederlink Earth Station Terminal Equipment  
 FFT Fast Fourier Transform  
 FIS Feederlink Earth Station Interface Simulator  
 FIT Fault Isolation Tests  
 FIU Fax Interface Unit  
 FMT Fixed Mobile Terminal  
 FMA Field Programmable Gate Array  
 FPMH Failures per Million Hours  
 FRO Frequency Reference Oscillator  
 FT Fault Tolerant  
 FTE Fax Terminal Equipment  
 FTIN Forward Terminal Identification Number  
 G/T Gain to System Noise Ratio  
 GBF Gateway/Base Function  
 GBS Gateway Base System  
 GC Group Controller  
 GC-I Interstation signaling channel from Group Controller to Feederlink Earth Station  
 GC-S Time Division Multiplex Signaling channel from Group Controller to Mobile Terminal

GCSST GC-S Search Time  
 GEN Generator  
 GHz Giga (1,000,000,000) Hertz (cycles per second)  
 GMACS  
     Graphical Monitor And Control System  
 GPIB General Purpose Instrument Bus  
 GPS Global Positioning System  
 GS Gateway Station  
 GSI GC-S Selector Identifier  
 10 GW Gateway  
     GWS Gateway Switch  
     GWS/BSS Gateway Switch/Base Station Switch  
     H/W Hardware  
     HCHREQ Handoff Channel Request  
 15 HDP Hardware Development Plan  
     HLR Home Location Register  
     HMI Human Machine Interface  
     HOT Hand-off Test  
     HPA High Power Amplifier  
 20 HRS Hardware Requirements Specification  
     HWCI Hardware Configuration Item  
     HW/SW Hardware/Software  
     Hz Hertz  
     I In Phase channel  
 25 IC Interexchange Carrier  
     ICD Interface Control Document  
     ICI Instrument Control Interface  
     ICP Intelligent Cellular Peripheral  
     ICU Interstation Channel Unit  
 30 ICWG Interface Control Working Group/Interface Coordination Working Group  
     ID Identification  
     IF Intermediate Frequency  
     IFIS Intermediate Frequency Subsystem  
 35 IFL Interfacility Link  
     IF IFL Intermediate Frequency Internal Facility Link  
     IHO Interstation Hand-Off  
     IICD Internal Interface Control Document  
     IICWG Internal Interface Control Working Group  
 40 IM Intermodulation  
     IMBE Improved Multiband Excitation  
     IOC Input/Output Controller  
     IP Internet Protocol  
     ISCU Interstation Signaling Channel Unit/Interstation Channel Unit  
 45 ISDN Integrated Services Digital Network  
     ISL Interstation Signaling Link  
     ISO International Standards Organization  
     IVDCPD Integrated Voice & Data Call Processing Demonstration  
 50 IVDM Integrated Voice/Data Mobile Terminal  
     KBPS Kilo (1,000) Bits per Second  
     kHz Kilohertz  
     KLNA K-band Low Noise Amplifier  
 55 KP Key Pulse  
     LAN Local Area Network  
     LAP Link Access Procedure  
     LAPB Link Access Procedure using a balanced mode of operation  
 60 LATA Local Access and Transport Area  
     LBP Local Blocking Probability  
     LCN Logical Channel Number  
     LLCSC Lower Level Computer Software Component  
     LLNA L-band Low Noise Amplifier  
 65 LLS Lower Level Specification  
     LNA Low Noise Amplifier  
     LOI Level of Integration

LPP Link Peripheral Processor  
 LRU Line Replaceable Unit  
 LRU Lowest Replaceable Unit  
 LSSGR Loyal Access and Transport Area Switching Systems Generic Requirements  
 MAP Maintenance Administrative Position  
 MAP Mobile Application Part  
 M bit 'More Data' bit in X.25  
 M&C Monitor and Control  
 MCC Management Control Center  
 MCGID Mobile Data Service Control Group Identification Number  
 MCR Management Information Repository  
 MDLP Mobile Data Service Data Link Protocol  
 MDS Mobile Data Service  
 MDSR MDLP Statistics Request  
 MEA Failure Modes and Effects Analysis  
 MEF Minimum Essential Functionality  
 MET Mobile Earth Terminal (a.k.a. MT)  
 MET-C Communication Channel Between Mobile Terminal and Feederlink Earth Station  
 MET-DRd Inbound Slotted Aloha Data Channel  
 MET-DRr Inbound Slotted Aloha Reservation Channel  
 MET-DT  
 Inbound Packet Time Division Multiple Access Channel  
 MET-SR Random Access Signaling Channel from Mobile Terminal to Group Controller  
 MET-ST Time Division Multiple Access signaling channel from Mobile Terminal to Group Controller  
 MF Multiple Frequency  
 MFID Manufacturer Identification  
 MGSP Mobile Terminal to Group Controller Signaling Protocol  
 MHz Mega Hertz (cycles per second)  
 MIB Management Information Base  
 MIR Management Information Region  
 MIRQ MT Initialization Request  
 MIS Mobile Terminal Interface Simulator  
 MIS Mobile Earth Terminal Interface Simulator  
 ML Message Layer  
 MLCSC Mid Level Computer Software Component  
 MLP Multilink Procedure  
 MMI Man Machine Interface  
 MMRS Mobile Road Service  
 MMSS Maritime Mobile Satellite Services  
 MNMS Mobile Data Service Network Management Subsystem  
 MNP Multi Network Protocol  
 MODEM MODulator/DEModulator  
 MOS Mean Opinion Score  
 MOV Method of Verification  
 MPLP Mobile Data Service Packet Layer Protocol  
 MPR MPR Teltech Inc.  
 MRI Minimum Request Interval  
 MRS Mobile Radio Service  
 MSAT Mobile Satellite  
 MSC Mobile Switching Center  
 MSS Mobile Satellite Service  
 MSSP Mobile Terminal Specialized Services Protocol  
 ms millisecond  
 MT Mobile Terminal  
 MT-C Communication Channel Between Mobile Terminal and Feederlink Earth Station  
 MT-DRd Inbound Slotted Aloha Data Channel  
 MT-DRr Inbound Slotted Aloha Reservation Channel  
 MT-DT Inbound Packet Time Division Multiple Access Channel

MT/NR Mobile Terminal/Net Radio  
 MT ASK Mobile Terminal Access Security Key  
 MTBF Mean-Time Between Failures  
 MTBRA Mean-Time Between Restoral Actions  
 5 MTCRS Mobile Telephone Cellular Roaming Service  
 MT-MET Mobile Terminal to Mobile Terminal  
 MT-MT Mobile Terminal to Mobile Terminal  
 MTP Mobile Data Service Transaction Protocol  
 MT-PSTN Mobile Terminal/Public Switched Telephone Network  
 10 MTS Mobile Telephone Service  
 MT-SR Random Access Signaling Channel from Mobile Terminal to Group Controller  
 MTSR MTP Statistics Request  
 15 MT-ST Time Division Multiple Access Signaling Channel from Mobile Terminal to Group Controller  
 MTTR Mean-Time to Repair  
 MTX Mobile Telephone Exchange  
 MULP Mobile Data Service Unacknowledged Link Protocol  
 20 MUSR MULP Statistics Request  
 NACN North American Cellular Network  
 NADP North American Dialing Plan  
 NANP North American Numbering Plan  
 NAP Network Access Processor  
 25 NAP-C Network Access Processor for the Communications Channel  
 NAP-CU Network Access Processor-Channel Unit  
 NAP-D Network Access Processor for the Data Channel  
 NAP-N Network Access Processor for the Network Radio Channel  
 30 NAP-S Network Access Processor for the Signaling Channel  
 NAS Network Access Subsystem  
 NASP National Aerospace Plan  
 NCC Network Communications Controller  
 35 NCC Network Control Center  
 NCC-RE Network Communications Controller Radio frequency Equipment  
 NCC-TE Network Communications Controller Terminal Equipment  
 40 NCS Network Control System  
 NCU Net Radio Control Unit  
 NCU Net Radio Channel Unit  
 NE Network Engineering  
 NEBS New Equipment Building System  
 45 NE/SE Network Engineering/System Engineering  
 NIM Network Module  
 NM Network Module  
 NMP Network Management Process  
 NMS Network Management System  
 50 NMS/CMIS Network Management System/Customer Management Information System  
 NOC Network Operations Center  
 NOC-FES Network Operations Center-Feederlink Earth Station  
 55 NPA Numbering Plan Area  
 NR Net Radio  
 NRCHA Net Radio Channel Assignment  
 NRCHREL Net Radio Channel Release  
 NRCHREQ Net Radio Channel Request  
 60 NRDVI Net Radio Dispatcher Voice Interface  
 NRS Net Radio Service  
 NRZ Non-Return to Zero  
 NVM Non-Volatile Memory  
 OA&M Operation, Administration, and Maintenance  
 65 O&M Operations and Maintenance  
 OJJ On the Job Training  
 OM Operational Measurements (from GWS)

OS Operating System  
 OSF Open Software Foundation  
 OSI Open Systems Interconnection  
 OSR Operational Support Review  
 PA Product Assurance  
 PAC Pre-emption Acknowledge Message  
 PAD Packet Assembler/Disassembler  
 PAP Product Assurance Plan  
 PBX Private Branch Exchange  
 PC Process Control  
 PCM Pulse Code Modulation  
 PC-RFMCP PC Based RFM Control Processor  
 PC-SCP PC Based Systems Control Processor  
 PCSTR Physical Channel Statistics Request  
 PCT Provisioning Criteria Table  
 PCU Pilot Control Unit  
 PCU Pilot Channel Unit  
 PDAMA Priority Demand Assignment Multiple Access  
 PDN Packet Data Network  
 PDR Preliminary Design Review  
 PDU Protocol Data Unit  
 PE Protocol Extension  
 PER Packet Error Rate  
 PERSP Packet Error Rate Sample Period  
 PERT Packet Error Rate Threshold  
 PIP Program Implementation Plan  
 PLP Packet Layer Protocol  
 PLT Pilot  
 PMR Project Management Review  
 PMT Pre-emption Message  
 PN Private Network  
 PN Pseudo Noise  
 PNIC Private Network Identification Code  
 PPM Pulses per Minute  
 PS Processor Subsystem  
 PSDN Private Switched Data Network  
 PSDN Public Switched Data Network  
 PSTN Public Switched Telephone Network  
 PTT Push-To-Talk  
 PVC Performance Virtual Circuit  
 PVT Permanent Verification Test/Performance Verification Test  
 Q Quadrature Phased Channel  
 QA Quality Assurance  
 Q bit 'Qualified Data' bit in X.25  
 QPSK Quadrature Phase Shift Keying  
 RAM Random Access Memory  
 RAM Reliability, Availability, Maintainability  
 RDB Relational DataBase  
 REMS Remote Environmental Monitoring System  
 Req Requirement  
 Rev Revision  
 RF Radio Frequency  
 RFE Radio Frequency Equipment  
 RF IFL Radio Frequency Inter Facility Link  
 RFM Radio Frequency Monitor  
 RFP Request For Proposal  
 RFS Radio Frequency Subsystem  
 RHCP Right Hand Circularly Polarized  
 RMS Remote Monitoring Station  
 RMS Remote Monitor Subsystem  
 RNO Remote NOC Operator  
 ROM Read Only Memory  
 RR Receiver Ready  
 RS Requirements Specification  
 RS-232C Electronics Industry Standard for unbalanced data circuits

RSP Radio Standard Procedure  
 RTIN Reverse Terminal Identification Number  
 RTM Requirements Traceability Matrix  
 RTP Reliable Transaction Protocol  
 5 RTR Reliable Transaction Router  
 RTS Reliable Transaction Service  
 RTS Receiver/Tuner System  
 Rx Receive  
 S/W Software  
 10 SCADA Supervisory Control and Data Acquisition  
 SCCP Signaling Connection Control Part  
 SCPC Single Channel Per Carrier  
 SCR Software Change Request  
 SCS System Common Software  
 15 SCU Signaling Channel Unit  
 SDD Software Design Description  
 SDID Seller Data Item Description  
 SDLC Synchronous Data Link Control  
 SDP Software Development Plan  
 20 SDPAP Software Development Product Assurance Plan  
 SDR System Design Review  
 SDRL Seller Data Requirements List  
 SE Systems Engineering  
 SEC Setup Complete Message  
 25 SEDP Software Engineering Development Plan  
 SEE Software Engineering Environment  
 SEEP Software Engineering Environment Plan  
 SID System Identifier Code  
 SIF System Integration Facility  
 30 SIT Special Information Tones  
 SLOC Source Lines of Code  
 SLSS Station Logic and Signaling Subsystem  
 SM Site Manager  
 SMAC Station Monitor Alarm and Control Subsystem  
 35 SMDS Satellite Mobile Data Service  
 SMP Software Management Plan  
 SMRS Satellite Mobile Radio Service  
 SMSC Satellite Mobile Switching Center  
 SMTS Satellite Mobile Telephone Service  
 40 SNA Systems Network Architecture  
 SNAC Satellite Network Access Controller  
 SNACS Satellite Network Access Controller Subsystem  
 SNMP Simple Network Management Protocol  
 SNR Signal to Noise Ratio  
 45 SOC Satellite Operation Center  
 SOW Statement of Work  
 SP Start Pulse  
 SPAP Software Product Assurance Plan  
 SPP Satellite Protocol Processor  
 50 SQL Software Query Language  
 SRR Systems Requirements Review  
 SRS Software Requirements Specification  
 SS7 Signaling System No. 7  
 SSA Sloppy Slotted Aloha  
 55 SSTS Satellite Transmission Systems, Inc.  
 STP Signal Transfer Point  
 STP System Test Program  
 STS System Test Station  
 STSI Satellite Transmission Systems, Inc.  
 60 SU Signaling Unit  
 SUES Shared-Use Earth Station  
 SVC Switched Virtual Circuit  
 SVVP Software Verification and Validation Plan  
 SVVPR Software Verification and Validation Plan Review  
 65 S/W Software  
 [TI] Top Level Specification  
 T-1 Digital Transmission link, 1.544 Mega-bits per second

TCP/IP Transmission Control Protocol/Internet Protocol  
 TCAP Transactions Capabilities Application Part  
 TCF Training Check Frame  
 TD Transmission Demonstration  
 TDM Time Division Multiplex  
 TDMA Time Division Multiple Access  
 TDMSI Time Division Multiplex Selector ID  
 TE Terminal Equipment  
 Telecom Telephonic Communications  
 TDM Time Division Multiplex  
 TDMA TDM Access  
 TID Terminal Identification  
 TIM Timing  
 TIM Technical Interchange Meeting  
 TIN Terminal Identification Number  
 TIS Terrestrial Interface Subsystem  
 TLCS Top Level Computer Software Component  
 TLS Top Level Specification  
 TMI Telesat Mobile Incorporated  
 TMS Test and Monitor Station  
 TNI Terrestrial Network Interface  
 TPP Test Plan and Procedure  
 TT&C Telemetry, Tracking and Control  
 Tx Transmit  
 UCN Up CoNverter  
 UDS Unacknowledged Data Delivery Service  
 UIS User Interface Subsystem  
 UPC Uplink Power Control  
 UTR Universal Tone Receiver  
 UW Unique Words  
 V&V Verification and Validation  
 VAC Value-Added Carrier  
 VAX Model Identification of a Digital Equipment Corporation system  
 VAX Virtual Address extension (proprietary name used by DEC for some of its computer systems)  
 VCN Virtual Circuit Number  
 VF Voice Frequency  
 VLR Visitor Location Register  
 VN Virtual Network  
 VPN Virtual Private Network  
 VUP VAX Unit of Processing  
 V.22bis Modem Standard for 24(0) 0 Baud Service Over Telephone Lines  
 V.25 Procedure for setting up a data connection on the Public Switched Telephone Network  
 V.26, V.28 Electrical specification of interchange circuits at both the Data Terminal Equipment and Data Communications Equipment sides of the interface (similar to RS-232-C)  
 V.32 High Speed Serial Link, Physical Layer Definition  
 V.35 X.25 physical layer interface used to access wideband channels (at data rates up to 64 kbit/s)  
 WAN Wide Area Network  
 XCR X.25 Configuration Request  
 XICD External Interface Control Document  
 XICWG External Interface Control Working Group  
 X.3 Specification for facilities provided by the Packet Assembler/Disassembler  
 X.21 X.25 physical layer interface for Data Terminal Equipment and Data Communications Equipment using synchronous transmission facilities  
 X.21bis X.25 physical layer interface for Data Terminal Equipment designed for interfacing to synchronous V-series modems to access data networks  
 X.25 Specification for interface between data terminal equipment and data communications equipment for terminals operating in packet mode

X.28 specification for interaction between local terminal and packet assembler/disassembler  
 X.29 specification for interaction between packet assembler/disassembler and remote packet mode terminal  
 We claim:  
 1. A satellite network system comprising:  
 a satellite antenna for receiving and transmitting messages via a satellite and satellite beams to and from feederlink earth stations (FESs) connected to at least one land line communications network and mobile earth terminals (METs) of a mobile communication system;  
 a satellite communication switching office connected to said antenna and coupled through a satellite interface system to a central controller; and  
 a network operations center (NOC) for managing and controlling resources of the satellite network system, the NOC communicating with various internal and external entities via a control network, said NOC comprising:  
 data management means for transmission and receipt of information with other components of the network operations center, said data management means including a NOC data base;  
 configuration management means for allocating system resources;  
 network management means for updating network functions;  
 call records management means for enabling monitoring of customer usage;  
 event management means for detecting fault conditions;  
 operator interface means for transmitting system information to an operator station;  
 a router for routing configuration update requests to a plurality of NOC components and for receiving polling update request responses from said components; and  
 a configuration data base server for updating said NOC data base for each update request upon receipt of positive responses from all of the components poled for the respective update request.  
 2. A satellite network system as recited in claim 1, wherein said network management means comprises historian means for recording performance of the network over time.  
 3. A satellite network system as recited in claim 2, wherein said historian means collects statistics regarding resource utilization and calls in progress.  
 4. A satellite network system as recited in claim 1, wherein said network management means further comprises process control means for controlling NOC startup and shutdown.  
 5. A satellite network system as recited in claim 1, wherein said network management means comprises a management information repository (MIR) server for receiving network update information and exporter means for transmitting network management information to the NOC data base.  
 6. A satellite network system comprising:  
 a satellite antenna for receiving and transmitting messages via a satellite and satellite beams to and from feederlink earth stations (FESs) connected to at least one land line communications network and mobile earth terminals (METs) of a mobile communication system;  
 a satellite communication switching office connected to said antenna and coupled through a satellite interface system to a central controller; and

- a network operations center (NOC) for managing and controlling resources of the satellite network system the NOC communicating with various internal and external entities via a control network, said NOC comprising: data management means for transmission and receipt of information with other components of the network operations center, said data management means including a NOC data base;
- configuration management means for allocating system resources;
- network management means for updating network functions; said network management means including watchdog means for transmitting an alarm in response to an abnormal condition;
- call records management means for enabling monitoring of customer usage;
- event management means for detecting fault conditions said event management means including a watchdog event sink for receiving events data from said watchdog means and communications ground segment (CGS) sink means for receiving CGS event data; and operator interface means for transmitting system information to an operator station.
7. A satellite network system as recited in claim 1, wherein said abnormal condition is a lack of available memory a system disk and said alarm is displayed on an operator screen at said operator station.
8. A satellite network system as recited in claim 6, wherein said event management means further comprises event logger means for logging event messages to a file to be stored in said NOC data base.
9. In a mobile satellite system including a satellite communication switching office and network system having a satellite antenna for receiving and transmitting a satellite message via a satellite and satellite beams to and from feederlink earth stations (FESs) and mobile earth terminals (METs) using a mobile communication system, a satellite interface system, a central controller receiving and transmitting the satellite message to and from the satellite communication switching office, the mobile satellite system being responsively connected to said mobile communication system and comprising:
- a network operations center (NOC) managing and controlling the resources of the satellite network system and carrying out the administrative functions associated with the management of the network system, the NOC communicating with various internal and external entities via a control network;
- a first network communications controller (NCC) managing the real time allocation of circuits between METs and FESs for the purposes of supporting communications, available circuits being held in circuit pools managed by group controllers (GCs) within the NCC, the NCC communicating with the NOC via a satellite network internetwork, with FESs via Ku-to-Ku band interstation signaling channels or terrestrial links, and with METs via Ku-to-L band signaling channels;
- a FES supporting communications links between METs, the public switched telephone network (PSTN), private networks, and other METs, call completion and service feature management being accomplished via inband signaling over the communication channel following the establishment of such a channel, the FES including a gateway FES providing mobile telephone service (MTS) and mobile telephone cellular roaming service (MTCRS) services, and a base FES providing mobile radio service (MRS) and net radio (NR) services;

- a customer management information system providing customers and service providers with assistance and information including problem resolution, service changes, and billing/usage data, customers including individual MET owners and fleet managers of larger corporate customers;
- a network engineering system developing network plans and performing analysis in support of the system including analyzing the requirements of the network, reconciling expected traffic loads with the capability and availability of space and ground resources to produce frequency plans for the different beams within the system, and defining contingency plans for failure situations;
- a system engineering system engineering the network subsystems, equipment and software which is needed to expand capacity to meet increases in traffic demands and to provide new features and services;
- a group controller subsystem (GCS) incorporating one or multiple group controllers (GC), each GC maintaining state machines for every call in progress within its control group and allocating and de-allocating circuits for FES-MET calls within each beam of the system, managing virtual network call processing, MET authentication, and providing elements of call accounting, the GC providing satellite bandwidth resources to the NOC for AMS(R)S resource provisioning and monitoring the performance of call processing and satellite circuit pool utilization, and performing MET management, commissioning and periodic performance verification testing and database management.
10. A mobile satellite system as recited in claim 9, wherein said NOC comprises:
- data management means for transmission and receipt of information with other components of the network operations center, said data management means including a NOC data base;
- configuration management means for allocating system resources;
- network management means for updating network functions;
- call records management means for enabling monitoring of customer usage;
- event management means for detecting fault conditions; and
- operator interface means for transmitting system information to an operator station.
11. A mobile satellite system as recited in claim 10, wherein said call records management means comprises:
- a first server for receiving satellite call usage records from the GCs and a second server for receiving nonsatellite call usage records from at least one gateway switch (GWS), each of said servers coupled to said NOC data base for storage therein of said usage records, said servers further coupled to said CMIS for transmission thereto of usage information.
12. A mobile satellite system as recited in claim 10, wherein said operator interface means comprises:
- session manager means for logging into the NOC by an operator;
- access security encryption means for encrypting for encrypting request transactions;
- operator message interface means for interfacing an operator with electronic mail; and



**45**

resource allocation means for enabling the operator to modify system operation.

**13.** A mobile satellite system as recited in claim **10**, wherein said data management means further comprises:

a router for routing configuration update requests to a plurality of NOC components and for receiving poling update request responses from said components;

**46**

a configuration data base server for updating said NOC data base for each update request upon receipt of positive responses from all of the components poled for the respective update request; and

communication means for exporting information from the NOC database to NE/SE and CMIS.

\* \* \* \* \*