



- (51) **International Patent Classification:**  
*H03F 1/30* (2006.01)      *H03F 3/189* (2006.01)
- (21) **International Application Number:**  
PCT/US2010/044033
- (22) **International Filing Date:**  
30 July 2010 (30.07.2010)
- (25) **Filing Language:** English
- (26) **Publication Language:** English
- (30) **Priority Data:**  
61/230,089      30 July 2009 (30.07.2009)      US  
12/704,432      11 February 2010 (11.02.2010)      US
- (71) **Applicant (for all designated States except US):** QUALCOMM INCORPORATED [US/US]; Attn: International IP Administration, 5775 Morehouse Drive, San Diego, California 92121 (US).
- (72) **Inventors; and**
- (75) **Inventors/Applicants (for US only):** MARRA, Thomas D. [US/US]; 5775 Morehouse Drive, San Diego, California 92121 (US). HADJICHRISTOS, Aristotele [US/US]; 5775 Morehouse Drive, San Diego, California 92121 (US). PLETCHER, Nathan, M. [US/US]; 5775 Morehouse Drive, San Diego, California 92121 (US).
- (74) **Agent:** MOBARHAN, Ramin; Attn: International IP Administration, 5775 Morehouse Drive, San Diego, California 92121 (US).

- (81) **Designated States (unless otherwise indicated, for every kind of national protection available):** AE, AG, AL, AM, AO, AT, AU, AZ, BA, BB, BG, BH, BR, BW, BY, BZ, CA, CH, CL, CN, CO, CR, CU, CZ, DE, DK, DM, DO, DZ, EC, EE, EG, ES, FI, GB, GD, GE, GH, GM, GT, HN, HR, HU, ID, IL, IN, IS, JP, KE, KG, KM, KN, KP, KR, KZ, LA, LC, LK, LR, LS, LT, LU, LY, MA, MD, ME, MG, MK, MN, MW, MX, MY, MZ, NA, NG, NI, NO, NZ, OM, PE, PG, PH, PL, PT, RO, RS, RU, SC, SD, SE, SG, SK, SL, SM, ST, SV, SY, TH, TJ, TM, TN, TR, TT, TZ, UA, UG, US, UZ, VC, VN, ZA, ZM, ZW.
- (84) **Designated States (unless otherwise indicated, for every kind of regional protection available):** ARIPO (BW, GH, GM, KE, LR, LS, MW, MZ, NA, SD, SL, SZ, TZ, UG, ZM, ZW), Eurasian (AM, AZ, BY, KG, KZ, MD, RU, TJ, TM), European (AL, AT, BE, BG, CH, CY, CZ, DE, DK, EE, ES, FI, FR, GB, GR, HR, HU, IE, IS, IT, LT, LU, LV, MC, MK, MT, NL, NO, PL, PT, RO, SE, SI, SK, SM, TR), OAPI (BF, BJ, CF, CG, CI, CM, GA, GN, GQ, GW, ML, MR, NE, SN, TD, TG).

**Declarations under Rule 4.17:**

- as to applicant's entitlement to apply for and be granted a patent (Rule 4.17(ii))
- as to the applicant's entitlement to claim the priority of the earlier application (Rule 4.17(iii))

[Continued on next page]

(54) **Title:** BIAS CURRENT MONITOR AND CONTROL MECHANISM FOR AMPLIFIERS

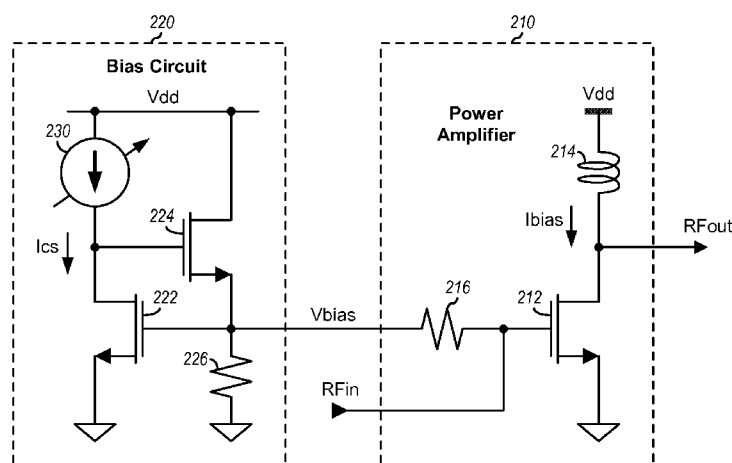

FIG. 2

(57) **Abstract:** Techniques for monitoring and controlling bias current of amplifiers are described. In an exemplary design, an apparatus may include an amplifier and a bias circuit. The amplifier may include at least one transistor coupled to an inductor. The bias circuit may generate at least one bias voltage for the at least one transistor in the amplifier to obtain a target bias current for the amplifier. The bias circuit may generate the at least one bias voltage based on a voltage across the inductor in the amplifier, or a current through a current mirror formed with one of the at least one transistor in the amplifier, or a gate-to-source voltage of one of the at least one transistor in the amplifier, or a voltage in a replica circuit replicating the amplifier, or a current applied to the amplifier with a switched mode power supply disabled.

WO 2011/014849 A3



**Published:**

**(88) Date of publication of the international search report:**

23 June 2011

- *with international search report (Art. 21(3))*
- *before the expiration of the time limit for amending the claims and to be republished in the event of receipt of amendments (Rule 48.2(h))*

# INTERNATIONAL SEARCH REPORT

International application No PCT/US2010/044033
---

**A. CLASSIFICATION OF SUBJECT MATTER**  
 INV. H03F1/30 H03F3/189  
 ADD.  
 According to International Patent Classification (IPC) or to both national classification and IPC

**B. FIELDS SEARCHED**  
 Minimum documentation searched (classification system followed by classification symbols)  
 H03F  
 Documentation searched other than minimum documentation to the extent that such documents are included in the fields searched

Electronic data base consulted during the international search (name of data base and, where practical, search terms used)  
 EP0-Internal

**C. DOCUMENTS CONSIDERED TO BE RELEVANT**

Category*	Citation of document, with indication, where appropriate, of the relevant passages	Relevant to claim No.
X	DE 198 51 718 A1 (MITSUBISHI ELECTRIC CORP [JP]) 18 November 1999 (1999-11-18) figures 11,12	1-3
X	----- US 2006/066410 A1 (RAZAVI BEHZAD [US] ET AL) 30 March 2006 (2006-03-30) figure 2	1-3
X	----- EP 1 376 855 A2 (MOTOROLA INC [US]) 2 January 2004 (2004-01-02) figure 3	1-3
X	----- US 6 114 912 A (ASHBY KIRK B [US] ET AL) 5 September 2000 (2000-09-05) figure 4	1-3
	----- -/--	

Further documents are listed in the continuation of Box C.       See patent family annex.

\* Special categories of cited documents :

<p>"A" document defining the general state of the art which is not considered to be of particular relevance</p> <p>"E" earlier document but published on or after the international filing date</p> <p>"L" document which may throw doubts on priority claim(s) or which is cited to establish the publication date of another citation or other special reason (as specified)</p> <p>"O" document referring to an oral disclosure, use, exhibition or other means</p> <p>"P" document published prior to the international filing date but later than the priority date claimed</p>	<p>"T" later document published after the international filing date or priority date and not in conflict with the application but cited to understand the principle or theory underlying the invention</p> <p>"X" document of particular relevance; the claimed invention cannot be considered novel or cannot be considered to involve an inventive step when the document is taken alone</p> <p>"Y" document of particular relevance; the claimed invention cannot be considered to involve an inventive step when the document is combined with one or more other such documents, such combination being obvious to a person skilled in the art.</p> <p>"&amp;" document member of the same patent family</p>
--	--

Date of the actual completion of the international search  <p style="text-align: center; font-size: 1.2em;">20 April 2011</p>	Date of mailing of the international search report  <p style="text-align: center; font-size: 1.2em;">28/04/2011</p>
---	---

Name and mailing address of the ISA/ European Patent Office, P.B. 5818 Patentlaan 2 NL - 2280 HV Rijswijk Tel. (+31-70) 340-2040, Fax: (+31-70) 340-3016	Authorized officer  <p style="text-align: center; font-size: 1.2em;">Kurzbaauer, Werner</p>
--	---

## INTERNATIONAL SEARCH REPORT

International application No

PCT/US2010/044033

C(Continuation). DOCUMENTS CONSIDERED TO BE RELEVANT		
Category*	Citation of document, with indication, where appropriate, of the relevant passages	Relevant to claim No.
X	US 6 392 492 B1 (YUAN XIAOJUEN [US]) 21 May 2002 (2002-05-21) figure 1 -----	1-3
X	US 2004/263256 A1 (ISHIKAWA MAKOTO [JP] ET AL) 30 December 2004 (2004-12-30) the whole document -----	1-3
X	US 2007/008038 A1 (KLEPSE BERND-ULRICH [DE] ET AL) 11 January 2007 (2007-01-11) the whole document -----	1,2
X	US 2006/033577 A1 (NAKAMIZO HIDEYUKI [JP] ET AL) 16 February 2006 (2006-02-16) the whole document -----	1-3
X	US 2004/130392 A1 (SAITO NORIAKI [JP]) 8 July 2004 (2004-07-08) figure 3 -----	1-3
X	US 2008/143445 A1 (NAKAMURA SHIGEKI [JP] ET AL) 19 June 2008 (2008-06-19) figure 3 -----	1-3
A	US 6 091 302 A (AREVALO AUGUSTO [US]) 18 July 2000 (2000-07-18) the whole document -----	4-8, 30-39
A	GB 2 301 248 A (MOTOROLA GMBH [DE]) 27 November 1996 (1996-11-27) page 5, line 23 - page 7, line 18; figure 1 -----	4-8, 30-39
A	US 2003/137355 A1 (LIN ALLAN MING-LUN [US]) 24 July 2003 (2003-07-24) figure 3 -----	4-8, 30-39
A	EP 1 693 958 A1 (EADS DEUTSCHLAND GMBH [DE]) 23 August 2006 (2006-08-23) paragraph [0011] - paragraph [0020]; figure 3 -----	4-8, 30-39
A	EP 1 855 379 A1 (ST MICROELECTRONICS SRL [IT]) 14 November 2007 (2007-11-14) the whole document -----	4-8
A	US 2009/153248 A1 (SUN BO [US] ET AL) 18 June 2009 (2009-06-18) figures 10,11 -----	9-17, 30-39
X	GB 2 448 525 A (ACP ADVANCED CIRCUIT PURSUIT AG [CH]) 22 October 2008 (2008-10-22) page 10, line 25 - page 12, line 15; figures 8,9 -----	18,20, 30,36,39
	----- -/--	

## INTERNATIONAL SEARCH REPORT

International application No

PCT/US2010/044033

C(Continuation). DOCUMENTS CONSIDERED TO BE RELEVANT

Category*	Citation of document, with indication, where appropriate, of the relevant passages	Relevant to claim No.
X	JP 9 307369 A (DENSO CORP) 28 November 1997 (1997-11-28) figure 1 abstract -----	18,30, 31,36,39
X	EP 0 385 641 A2 (AMERICAN TELEPHONE & TELEGRAPH [US] AT & T CORP [US]) 5 September 1990 (1990-09-05) figure 5 -----	22
X	US 2007/057728 A1 (AUTTI MARKO [FI]) 15 March 2007 (2007-03-15) paragraph [0046]; figures 6,7 -----	22
X	WO 2004/070941 A2 (UNIV ARIZONA [US]; ABEDINPOUR SIAMAK [US]; KIAEI SAYFE [US]) 19 August 2004 (2004-08-19) the whole document -----	22

# INTERNATIONAL SEARCH REPORT

International application No.  
PCT/US2010/044033

## Box No. II Observations where certain claims were found unsearchable (Continuation of item 2 of first sheet)

This international search report has not been established in respect of certain claims under Article 17(2)(a) for the following reasons:

1.  Claims Nos.:  
because they relate to subject matter not required to be searched by this Authority, namely:
  
2.  Claims Nos.:  
because they relate to parts of the international application that do not comply with the prescribed requirements to such an extent that no meaningful international search can be carried out, specifically:
  
3.  Claims Nos.:  
because they are dependent claims and are not drafted in accordance with the second and third sentences of Rule 6.4(a).

## Box No. III Observations where unity of invention is lacking (Continuation of item 3 of first sheet)

This International Searching Authority found multiple inventions in this international application, as follows:

see additional sheet

1.  As all required additional search fees were timely paid by the applicant, this international search report covers all searchable claims.
  
2.  As all searchable claims could be searched without effort justifying an additional fees, this Authority did not invite payment of additional fees.
  
3.  As only some of the required additional search fees were timely paid by the applicant, this international search report covers only those claims for which fees were paid, specifically claims Nos.:
  
4.  No required additional search fees were timely paid by the applicant. Consequently, this international search report is restricted to the invention first mentioned in the claims; it is covered by claims Nos.:

### Remark on Protest

- The additional search fees were accompanied by the applicant's protest and, where applicable, the payment of a protest fee.
- The additional search fees were accompanied by the applicant's protest but the applicable protest fee was not paid within the time limit specified in the invitation.
- No protest accompanied the payment of additional search fees.

## FURTHER INFORMATION CONTINUED FROM PCT/ISA/ 210

This International Searching Authority found multiple (groups of) inventions in this international application, as follows:

## 1. claims: 1-3

An apparatus comprising:  
an amplifier comprising a first transistor; and a bias circuit comprising a second transistor coupled to the first transistor in the amplifier, the first and second transistors form a current mirror, the bias circuit generates a bias voltage for the first and second transistors to obtain a target bias current for the first transistor.

---

## 2. claims: 4-8

An apparatus comprising:  
an amplifier comprising a transistor coupled to an inductor;  
a sensing circuit coupled to the inductor and to measure a voltage across the inductor; and  
a bias circuit coupled to the transistor and to generate a bias voltage for the transistor based on the measured voltage across the inductor to obtain a target bias current for the transistor.

---

## 3. claims: 9-17

An apparatus comprising:  
an amplifier comprising first and second transistors coupled in a stack;  
a sensing circuit coupled to the second transistor in the amplifier and to measure a gate-to-source voltage,  $V_{gs}$ , of the second transistor; and  
a bias circuit coupled to at least one transistor among the first and second transistors and to generate at least one bias voltage for the at least one transistor based on the measured  $V_{gs}$  voltage of the second transistor to obtain a target bias current for the first and second transistors.

---

## 4. claims: 18-21

An apparatus comprising:  
an amplifier comprising at least one transistor;  
a replica circuit comprising at least one transistor replicating the at least one transistor in the amplifier;  
and  
a feedback circuit coupled to the amplifier and the replica circuit and to sense a first voltage in the amplifier, to sense a second voltage in the replica circuit, and to generate a bias voltage for the amplifier based on the first and second voltages.

---

**FURTHER INFORMATION CONTINUED FROM PCT/ISA/ 210**

5. claims: 22-29

An apparatus comprising:  
an amplifier to amplify an input signal and provide an output signal;  
a switched mode power supply (SMPS) coupled to the amplifier and to receive a first supply voltage and provide a second supply voltage to the amplifier; and  
a bias circuit coupled to the amplifier and to generate a bias voltage for the amplifier to obtain a target bias current for the amplifier.

---

6. claims: 30-39

A method of adjusting bias current generating at least one bias voltage for at least one transistor in an amplifier based on a measurement to obtain a target bias current for the amplifier and the corresponding apparatus.

---



# INTERNATIONAL SEARCH REPORT

Information on patent family members

International application No

PCT/US2010/044033

Patent document cited in search report	Publication date	Patent family member(s)	Publication date	
DE 19851718	A1	18-11-1999	JP 11317628 A US 6127892 A	16-11-1999 03-10-2000
US 2006066410	A1	30-03-2006	JP 2006094532 A	06-04-2006
EP 1376855	A2	02-01-2004	JP 2004040795 A US 2004000953 A1	05-02-2004 01-01-2004
US 6114912	A	05-09-2000	NONE	
US 6392492	B1	21-05-2002	NONE	
US 2004263256	A1	30-12-2004	CN 1578127 A JP 2005020518 A US 2008191806 A1	09-02-2005 20-01-2005 14-08-2008
US 2007008038	A1	11-01-2007	DE 102005061572 A1	25-01-2007
US 2006033577	A1	16-02-2006	WO 2004086613 A1	07-10-2004
US 2004130392	A1	08-07-2004	JP 4080298 B2 JP 2004153378 A	23-04-2008 27-05-2004
US 2008143445	A1	19-06-2008	JP 2008153979 A	03-07-2008
US 6091302	A	18-07-2000	NONE	
GB 2301248	A	27-11-1996	GB 2345211 A	28-06-2000
US 2003137355	A1	24-07-2003	WO 03063342 A1	31-07-2003
EP 1693958	A1	23-08-2006	DE 102005007159 A1 US 2006192619 A1	24-08-2006 31-08-2006
EP 1855379	A1	14-11-2007	US 2007273448 A1	29-11-2007
US 2009153248	A1	18-06-2009	CN 101904088 A EP 2243216 A2 JP 2011507458 T KR 20100092518 A WO 2009079468 A2	01-12-2010 27-10-2010 03-03-2011 20-08-2010 25-06-2009
GB 2448525	A	22-10-2008	CN 101663812 A EP 2143202 A1 WO 2008128706 A1 US 2010182091 A1	03-03-2010 13-01-2010 30-10-2008 22-07-2010
JP 9307369	A	28-11-1997	NONE	
EP 0385641	A2	05-09-1990	CA 2006683 A1 DE 69015663 D1 DE 69015663 T2 FI 97575 B HK 5396 A JP 2067769 C JP 2291704 A JP 7101821 B US 5105164 A	31-08-1990 16-02-1995 18-05-1995 30-09-1996 19-01-1996 10-07-1996 03-12-1990 01-11-1995 14-04-1992

# INTERNATIONAL SEARCH REPORT

Information on patent family members

International application No

PCT/US2010/044033

Patent document cited in search report	Publication date	Patent family member(s)	Publication date	
US 2007057728	A1	15-03-2007	CN 101263652 A	10-09-2008
			EP 1925076 A1	28-05-2008
			WO 2007031594 A1	22-03-2007
WO 2004070941	A2	19-08-2004	NONE	