

(19) World Intellectual Property Organization
International Bureau



(43) International Publication Date
20 November 2008 (20.11.2008)

PCT

(10) International Publication Number
WO 2008/140585 A1

(51) International Patent Classification:
G03F 1/00 (2006.01) H01L 21/302 (2006.01)
G03C 5/00 (2006.01)

(74) Agent: **ALTMAN, Daniel, E.**; Knobbe, Martens, Olson & Bear, LLP, 2040 Main Street, 14th Floor, Irvine, CA 92614 (US).

(21) International Application Number:
PCT/US2007/085447

(81) Designated States (unless otherwise indicated, for every kind of national protection available): AE, AG, AL, AM, AT, AU, AZ, BA, BB, BG, BH, BR, BW, BY, BZ, CA, CH, CN, CO, CR, CU, CZ, DE, DK, DM, DO, DZ, EC, EE, EG, ES, FI, GB, GD, GE, GH, GM, GT, HN, HR, HU, ID, IL, IN, IS, JP, KE, KG, KM, KN, KP, KR, KZ, LA, LC, LK, LR, LS, LT, LU, LY, MA, MD, ME, MG, MK, MN, MW, MX, MY, MZ, NA, NG, NI, NO, NZ, OM, PG, PH, PL, PT, RO, RS, RU, SC, SD, SE, SG, SK, SL, SM, SV, SY, TJ, TM, TN, TR, TT, TZ, UA, UG, US, UZ, VC, VN, ZA, ZM, ZW.

(22) International Filing Date:
12 November 2007 (12.11.2007)

(25) Filing Language: English

(26) Publication Language: English

(30) Priority Data:
60/860,619 22 November 2006 (22.11.2006) US

(84) Designated States (unless otherwise indicated, for every kind of regional protection available): ARIPO (BW, GH, GM, KE, LS, MW, MZ, NA, SD, SL, SZ, TZ, UG, ZM, ZW), Eurasian (AM, AZ, BY, KG, KZ, MD, RU, TJ, TM), European (AT, BE, BG, CH, CY, CZ, DE, DK, EE, ES, FI, FR, GB, GR, HU, IE, IS, IT, LT, LU, LV, MC, MT, NL, PL, PT, RO, SE, SI, SK, TR), OAPI (BF, BJ, CF, CG, CI, CM, GA, GN, GQ, GW, ML, MR, NE, SN, TD, TG).

(71) Applicant (for all designated States except US): **NEXGEN SEMI HOLDING, INC.** [US/US]; 30251 Golden Lantern, Suite E522, Laguna Niguel, CA 92677-5993 (US).

(72) Inventors; and

(75) Inventors/Applicants (for US only): **SCOTT, Jeffrey** [US/US]; 4494 Via Real, Carpinteria, CA 93013 (US). **ZANI, Michael** [US/US]; 5 Killini, Laguna Niguel, CA 92677 (US). **BENNAHMIA, Mark** [US/US]; 20710 Aime #111, Torrance, CA 90503 (US). **MAYSE, Mark** [US/US]; 10757 Inspiration Circle, Dublin, CA 94568 (US).

Published:
— with international search report
— before the expiration of the time limit for amending the claims and to be republished in the event of receipt of amendments

(54) Title: APPARATUS AND METHOD FOR CONFORMAL MASK MANUFACTURING

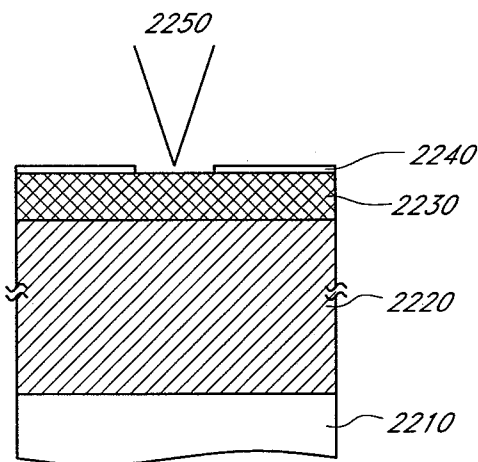

FIG. 22B

(57) Abstract: A manufacturing process technology creates a pattern on a first layer using a focused ion beam process. The pattern is transferred to a second layer, which may act as a traditional etch stop layer. The pattern can be formed on the second layer without irradiation by light through a reticle and without wet chemical developing, thereby enabling conformal coverage and very fine critical feature control. Both dark field patterns and light field patterns are disclosed, which may enable reduced or minimal exposure by the focused ion beam.

WO 2008/140585 A1

APPARATUS AND METHOD FOR CONFORMAL MASK MANUFACTURING

CROSS-REFERENCE TO RELATED APPLICATIONS

This application claims priority under 35 U.S.C. § 119(e) to United States Provisional Application Serial No. 60/860,619 filed on November 22, 2006, titled "APPARATUS AND METHOD FOR CONFORMAL MASK MANUFACTURING" (Atty. Docket No. SECL.005PR), which is hereby expressly incorporated by reference in its entirety.

BACKGROUND

Field

[0001] The present application relates to semiconductor manufacturing. More specifically, the present application relates to methods and apparatuses for direct write semiconductor manufacturing.

Description of the Related Art

[0002] Photolithography has been a key patterning step in most integrated circuit fabrication processes. Resist, a photosensitive organic, is spun on a workpiece, baked, and exposed in a pattern through a reticle, usually by ultraviolet (UV) light. After development and often a second bake, the surface is left partially covered by an inert organic film that resists various treatments to which the workpiece is subjected. Such treatments include material removal by wet chemical etch or by gaseous plasma etch, doping by ion implantation (e.g., broad beam implantation), and addition of material (e.g., metal lift-off). The preparation, exposure, development, clean, care, and stripping of resist can increase the number of fabrication steps tenfold, requiring expensive equipment and facilities to establish stable, qualified, and high yield fabrication.

[0003] Photolithography has been the main lithographic tool for processing patterns of resist down to 45 nanometers (nm). However, present and future microelectronics will require minimum feature sizes below 45 nm. While advances in a number of lithography techniques (e.g., ultraviolet (UV), enhanced ultraviolet (EUV) emersion, maskless emersion, laser, phase-shift, projection ion, and electron beam lithography (EBL)) can enable high-scale production at these dimensions, they are nearing their theoretical limits with respect to wavelength, overlay accuracy, and/or cost. Pushed to the limit, the weaknesses of each

process present difficult problems, and the resulting patterning defects can result in significant yield loss.

SUMMARY

[0004] In certain embodiments, a method for processing comprises providing a workpiece comprising a layer that is configured to be patterned by a particle beam and a first transfer layer thereunder, the particle beam patternable layer being thinner than the first transfer layer; and exposing regions of the particle beam patternable layer using a collimated beam of spatially and temporally resolved charged particles thereby changing said regions, wherein the first transfer layer is configured to be selectively processed relative to the particle beam patternable layer using a first process that removes regions of the first transfer layer substantially determined by the shape of the exposed regions of the particle beam patternable layer.

[0005] In certain embodiments, a method for forming structures comprises providing a workpiece comprising a layer that is configured to be patterned by a collimated beam of spatially and temporally resolved charged particles and a first transfer layer thereunder; exposing regions of the particle beam patternable layer to a stream of charged particles thereby changing said regions; removing the exposed regions of the particle beam patternable layer to reveal regions of the first transfer layer having a shape substantially determined by the shape of the exposed regions of the particle beam patternable layer; and performing a first process on the first transfer layer thereby removing regions of the first transfer layer having a shape substantially determined by the shape of the exposed regions of the particle beam patternable layer.

[0006] In certain embodiments, a method for processing comprises providing a workpiece comprising a layer that is configured to be patterned by a particle beam, a first transfer layer under the patternable layer, and a second transfer layer under the first transfer layer; and exposing regions of the particle beam patternable layer to a stream of charged particles thereby changing said regions, wherein the first transfer layer is configured to be selectively processed relative to the particle beam patternable layer using a first process that removes regions of the first transfer layer substantially determined by the shape of the exposed regions of the particle beam patternable layer, and wherein the selectivity of the first

removal process to the first transfer layer relative to the patternable layer is at least 10 times, and wherein the second transfer layer is configured to be selectively processed relative to the first transfer layer using a second process that removes regions of the second transfer layer substantially determined by the shape of the exposed regions of the particle beam patternable layer.

[0007] In certain embodiments, a method for forming structures comprises providing a workpiece comprising a layer that is configured to be patterned by a particle beam, a first transfer layer under the particle beam patternable layer, and a second transfer layer under the first layer, wherein the first transfer layer is configured to be selectively processed relative to the particle beam patternable layer using a first process that removes regions of the first transfer layer substantially determined by the shape of the exposed regions of the particle beam patternable layer, and wherein the selectivity of the first removal process to the first transfer layer relative to the particle beam patternable layer is at least 10 times, wherein the second transfer layer is configured to be selectively processed relative to the first transfer layer using a second process that removes regions of the second transfer layer substantially determined by the shape of the exposed regions of the particle beam patternable layer, and exposing regions of the particle beam patternable layer to a stream of charged particles thereby changing said regions; removing the exposed regions of the particle beam patternable layer to reveal regions of the first transfer layer having a shape substantially determined by the shape of the exposed regions of the particle beam patternable layer; performing the first removal process on the first transfer layer; and performing the second removal process on the second transfer layer.

[0008] In certain embodiments, an in-process workpiece comprises a substrate; a first transfer layer; a second transfer layer between the first transfer layer and the substrate, said second transfer layer comprising organic material; and a patterned layer of oxide, the first transfer layer disposed between the oxide layer and the second transfer layer, wherein the first transfer material is configured to be selectively etched relative to the oxide layer and relative to the second transfer layer, and wherein the second transfer layer is configured to be selectively etched relative to the first transfer layer.

[0009] In certain embodiments, a method for processing comprises providing a workpiece comprising a first transfer layer; and depositing material on regions of the first transfer layer using a particle beam thereby forming on the first transfer layer a layer having a pattern, wherein the first transfer layer is configured to be selectively processed relative to the patterned layer using a first process that removes regions of the first transfer layer substantially determined by the shape of the deposited regions of the patterned layer.

[0010] For purposes of summarizing the invention and the advantages achieved over the prior art, certain objects and advantages of the invention have been described herein above. Of course, it is to be understood that not necessarily all such objects or advantages may be achieved in accordance with any particular embodiment of the invention. Thus, for example, those skilled in the art will recognize that the invention may be embodied or carried out in a manner that achieves or optimizes one advantage or group of advantages as taught or suggested herein without necessarily achieving other objects or advantages as may be taught or suggested herein.

[0011] All of these embodiments are intended to be within the scope of the invention herein disclosed. These and other embodiments will become readily apparent to those skilled in the art from the following detailed description of the preferred embodiments having reference to the attached figures, the invention not being limited to any particular preferred embodiment(s) disclosed.

BRIEF DESCRIPTION OF THE DRAWINGS

[0012] These and other features, aspects, and advantages of the invention disclosed herein are described below with reference to the drawings of preferred embodiments, which are intended to illustrate and not to limit the invention.

[0013] Figure 1A is a perspective view of an example apparatus for controlled particle beam manufacturing.

[0014] Figure 1B is a top schematic view of the apparatus of Figure 1A.

[0015] Figure 2 is a schematic block diagram of an example charged particle beam column, exposure chamber, and control electronics.

[0016] Figure 3A is a schematic block view of an example charged particle column.

- [0017] Figure 3B schematically illustrates bunching of charged particles.
- [0018] Figure 3C schematically illustrates an example beam buncher.
- [0019] Figure 3D schematically illustrates an example beam blanker.
- [0020] Figure 4A illustrates an example writing strategy over a period of time.
- [0021] Figure 4B is a schematic block diagram of an example workpiece stage and positional control electronics.
- [0022] Figures 4C and 4D is a schematic block diagram illustrating an example beam measurement technique.
- [0023] Figure 5 illustrates example groups of charged particles in a digital beam.
- [0024] Figure 6A depicts a top schematic view of a deflector.
- [0025] Figure 6B is a perspective quarter cut-away view of the upper right quadrant of the deflector of Figure 6A.
- [0026] Figure 7 is a schematic block diagram of another example charge particle column.
- [0027] Figure 8 illustrates an example writing strategy.
- [0028] Figures 9A through 9C schematically illustrate cross-sections of a workpiece at various stages of an example digital beam assisted chemical etching process.
- [0029] Figures 10A through 10C schematically illustrate cross-sections of a workpiece at various stages of an example digital beam assisted deposition process.
- [0030] Figures 11A through 11D schematically illustrate cross-sections of a workpiece at various stages of an example digital beam implantation process.
- [0031] Figures 11E through 11I illustrate example modifications during a digital beam modification process.
- [0032] Figures 12A through 12C depict example schematic cross-sections of lightly doped drain structures processed with a controlled particle beam.
- [0033] Figures 13A and 13B depict an example schematic cross-section of a lateral channel doping structure processed with a controlled particle beam and a doping concentration profile thereof, respectively.

[0034] Figures 14A and 14B depict example schematic cross-sections of heterojunction insulating gate field effect transistor structures processed with a controlled particle beam.

[0035] Figure 15 depicts example schematic cross-sections of gallium arsenide diode structures over time as processed with a controlled particle beam.

[0036] Figures 16A through 16K depicts example schematic cross-sections of gallium arsenide microwave monolithic integrated circuit structures over time as processed with a controlled particle beam.

[0037] Figures 17 depict an example schematic cross-section of a heterojunction bipolar transistor structure processed with a controlled particle beam.

[0038] Figure 18 depicts example schematic cross-sections of a semiconductor structure over time as processed with a controlled particle beam.

[0039] Figure 19A depicts an example schematic top view of a radiation hardness structure processed with a controlled particle beam.

[0040] Figure 19B is a schematic cross-sectional view of the radiation hardness structure of Figure 19A taken along line 19B-19B.

[0041] Figure 20 depicts an exploded cross-sectional schematic view of an objective lens assembly.

[0042] Figures 21A through 21G schematically depict beam writing strategies.

[0043] Figures 22A through 22D schematically depict an example embodiment of a method for forming a conformal mask. Figure 22D shows the completed "dark field" conformal mask.

[0044] Figures 23A through 23F schematically depict another example embodiment of a method for forming a conformal mask. Figure 22F shows the completed "light field" conformal mask.

DETAILED DESCRIPTION OF THE PREFERRED EMBODIMENTS

[0045] Although certain preferred embodiments and examples are disclosed below, it will be understood by those in the art that the invention extends beyond the specifically disclosed embodiments and/or uses of the invention and obvious modifications

and equivalents thereof. Thus, it is intended that the scope of the invention herein disclosed should not be limited by the particular disclosed embodiments described below.

[0046] Smaller device geometries can be achieved by direct writing with a beam of charged particles. Focused ion beam (FIB) systems generally do not have sufficient ion exposure to support high throughput manufacturing. Furthermore, only relatively low speed deflection is available using existing ion optics/deflection electronics methodologies, preventing efficient direct write of layers patterned for semiconductor devices. As such, FIB has been limited to mask (e.g., reticle) and semiconductor repair. As FIB technology progressed, it supported the ability to simultaneously deposit, etch, and implant patterns directly on workpieces without the use of resist. Problems remained, however, including low energy systems with little-to-no wafer writing software, no metrology systems, and minimal beam current densities and deflection speeds necessary to support the lithography on a high manufacturing scale. Modifications and improvements to FIB systems in accordance with embodiments described herein can achieve suitable manufacturing throughput in both resist processing and resistless fabrication of semiconductor workpieces and other media (e.g., photomask, compact disk (CD), digital video disk (DVD), high definition DVD (HD DVD), Blue-Ray, etc.).

[0047] The physical properties of a beam of charged particles traveling along an axis with a distribution transverse to the axis can be modified to provide a high speed, digital (or "pulsed") distributed writing beam. Various methods can be used to create a wave of temporally and spatially defined high-density charged particle anti-nodes and low density (or no density) nodes, traveling in a longitudinal path of accelerated particles (herein referred to as a "digitized beam"). For example, a beam buncher can be used to create localized groups (or "flashes" or "packets") of the charged particles. These groups of charged particles can contain one or more charged particles. The digital beam is then passed through a deflector, whereupon variations in voltage cause the groups of charged particles to change position relative to the direction of propagation. Changes in voltage can be timed in phase with the particle anti-nodes, thereby yielding efficient deflection. The presence of a sharp edge of the node effectively provides fast beam blanking for direct write. Applying the digitized beam to the surface of a workpiece allows resistless patterned processing, including deposition,

etching, and/or implantation of material to the surface of the workpiece and/or high resolution resist exposure.

[0048] Figure 1A is a perspective view of an example apparatus 100 in accordance with certain embodiments disclosed herein. Figure 1B is a top schematic view of the apparatus 100 of Figure 1A. The apparatus 100 comprises an exposure chamber 102, a load lock chamber 104, a transport module 106, and a plurality of processing chambers 108. Although not illustrated, it will be understood that the apparatus 100 comprises a gas manifold system and an automated process controller, described in more detail below.

[0049] The load lock chamber 104 may house workpieces 101 that are not being processed, for example, before and/or after processing in the apparatus 100. In certain embodiments, the load lock chamber 104 is configured to achieve vacuum such that an automated material handling system (AMHS) 110 of the transport module 106 in communication with the load lock chamber 104 may insert and/or remove workpieces 101 without having to be pumped down to or up from vacuum between each transfer. In certain embodiments, the loadlock chamber 104 is configured to accept a front opening unified pod (FOUP).

[0050] The transport module 106 is configured to move workpieces 101 within the apparatus 100. The transport module 106 comprises an AMHS 110 configured to manipulate at least one workpiece 101. A suitable AMHS 110 can be chosen based on the design of the exposure chamber 102, the loadlock chamber 104, the transport module 106, and/or the process chambers 108. In certain embodiments, the AMHS 110 comprises a plurality of transport arms such that workpieces 101 may be manipulated simultaneously (or in parallel).

[0051] In some embodiments, the transport module 106 includes a workpiece prealigner, such that the workpieces 101 removed by the transport arm 110 and subsequently placed into the exposure chamber 102 or a process chamber 108 are in an orientation that is ready for processing in the exposure chamber 102 or a process chamber 108. For example, the prealigner may use charge-coupled device (CCD) or other imaging devices to locate a flat, notch, or other identifying feature of the workpiece 101. In some embodiments, the

prealigner is configured to determine overlay parameters of alignment features on the workpiece 101. The overlay parameters may comprise x and y offset, rotation, etc.

[0052] Depending on the type and size of the workpiece 101, a variety of vacuum and handling systems can be used in the apparatus 100. A system capable of processing a variety of workpieces preferably uses a high speed workpiece handling system. Workpiece-into-vacuum throughput can be increased by aligning the workpiece under vacuum on the workpiece stage instead of outside the vacuum system. A standard workpiece holder (e.g., a wafer magazine) can be pumped to high vacuum within a few minutes. Alignment of the workpiece 101 under vacuum may increase wafer into vacuum throughput.

[0053] In some embodiments, the transport module 106 comprises one or more processing substations, for example comprise one or more buffer zones to hold workpieces 101 between processing steps, a particle contamination detector, a temperature quenching station, and/or a metrology station. The metrology station may be selected from any tool appropriate for that type of workpiece, including, but not limited to, an energy dispersive analyzer (EDS), a wavelength dispersive analyze (WDS), a secondary ion mass spectrometer (SIMS), a scanning electron microscope (SEM), a two-dimensional laser scanning imager, a three-dimensional imaging laser radar (LADAR), a thermal imager, a millimeter wave imager, a workpiece imager, and a camera.

[0054] The exposure chamber 102 is configured to expose a workpiece 101 to a digital beam of charged particles. As shown in Figure 2, the exposure chamber 102 comprises a beam column 200, illustrated in more detail in Figure 3A. The beam column 200 comprises a charged particle source 202 for generating a stream of charged particles. Although systems and methods are described in certain embodiments herein with reference to ions, it will be understood that some systems and methods may utilize charged particles comprising electrons and positrons. Charged particles may include one or more species of positively and negatively charged ions, as well as singly, doubly, triply, etc. charged ions. In some embodiments, the charged particle source 202 is adapted to generate a plurality of ion species. In some embodiments, the charged particle source 202 is adapted to provide a current of 1,000 amperes/cm² (A/cm²) focused to a 10 nm spot as measured at the target.

[0055] Liquid metal ion source (LMIS) technology enables the formation of high current density charged particle beams. An example technique to create a LMIS is a heated reservoir of liquid metal from which a needle protrudes downward. The metal flows down the needle by capillary action. An electric field from an extraction electrode pulls the liquid at the tip of the needle into a sharp cusp (a "Taylor Cone") from which ions are emitted. The point source is very bright (e.g., about 10^9 A/steradian/cm²), and, with suitable optics, permits the beam diameter to be as small as 2 nm. A variety of alloys provides several ion species common for semiconductor fabrication.

[0056] Accelerating and focusing a distributed energy of ions can introduce chromatic aberrations resulting in a loss of current density efficiency of the ion optic system. The ion beam energy distribution can be measured as the beam full-width-half-max (FWHM) and can be distributed as much as 12%. Improving the current density efficiency and resolving long and short term stability issues can make LMIS performance adequate for a semiconductor processing tool. One aspect of various embodiments of the present invention is the realization that beams of charged particles are composed of a distribution of high and low energy tails, which can be advantageously grouped.

[0057] At least two mechanisms can contribute to the broadening of the energy distributions: first, effects related to the formation of the ions; and second, space charge forces after ion formation. Ion emissions from a LMIS source are formed either by direct field desorption of an ion at the emitter tip or by field ionization of desorbed atoms at some distance from the emitter tip. Ions generated close to the tip surface can exchange charge with neutral atoms further downstream, forcing a zero energy ion at that point. Since the electric field in the emitter area is high (e.g., between about 20 and 50 Volts/nm), ions formed at different distances from the emitter can have different energies. Space charge effects broaden the energy distribution of the beam, particularly at low velocities. Therefore, the column 200 preferably is configured to accelerate the ions to full energy directly after formation. The use of low-mass species may aid in ion acceleration when the use of such species is appropriate.

[0058] Space charge effects are also aggravated by higher currents. For the LMIS source, the width of the energy distribution is preferably proportional to the current to the 2/3

power. As such, practical application of traditional LMIS sources to lithography show behavior similar to electron beams.

[0059] A limitation on the maximum current density achievable with LMIS-based systems results from the energy distribution of the ion beam that is caused by the achromatic aberration in the upper ion optical system. However, the use of a beam digitizer 206 downstream of the charged particle source 202 that is configured to adjust the longitudinal spacing between charged particles so as to create temporally and spatially resolved groups of the charged particles along the axis of propagation can effectively slow faster moving particles and can speed slower moving particles to obtain a uniform velocity, and thus a uniform energy distribution (accelerating voltage) within each group of the digital beam, thereby reducing the effect of the charged particle source chromatic aberration, as illustrated in Figure 3B.

[0060] Similar to the drift of an electron beam, a LMIS Taylor cone emission unpredictably drifts, typically in a figure-8 pattern over about a one hour period. Undetected, this drift can cause pattern placement errors. Source lifetime and current stability are barriers to the practical application for production throughput processing tools using traditional LMIS sources. Further improvements at the charged particle source 202 can improve the stability and lifetime, thereby reducing frequent source replacement. The broadening of the energy distribution associated with ion formation can be reduced or minimized by operating the LMIS at low temperature, thereby decreasing the neutral atom density in the proximity of the tip. The energy distribution can also be reduced or minimized by choosing a low vapor pressure species, for example by selecting a doubly ionized species that has a low charge exchange cross-section and that is formed at the surface of the tip, known to have a narrow energy distribution, and by using a species that has the additional benefit of a small virtual source. It will be appreciated that other techniques can also be used.

[0061] In certain embodiments, extended lifetime of the charged particle source 202 may be achieved by conditioning the source driving parameters prior to operation. As such, the incorporation of an automated conditioning routine can contribute to the extended life and stability of the charged particle source 202. Additionally, a continuous flow strategy, such as impregnated electrode-type needles with hardened tips, can further extend the life

span of the charged particle source 202. Second order effects of improved life span can include emission current and position stability improvement. Source emission position stability can be successfully corrected by using an error feedback from occasional beam registrations and adjustment to source servomotors. Although increased ion beam current density is preferred, the column 200 in the exposure chamber 102 need not increase the beam current density.

[0062] Other charged particle sources 202 may also be used with the embodiments disclosed herein. For example and without limitation, the charged particle source 202 may comprise a plasma ion source (PIS), a volume plasma ion source (VPIS), a gas field ionization source (GFIS), a carbon nanotube field emitter, a free electron laser and a target, a pulsed laser ablation ion source, a magnetically confined plasma anode source (MAP), and a thermal field emission (TFE) electron source.

[0063] The stream of charged particles emanating from the charged particle source 202 is collimated and directed along a axis by a collimator 204. A variety of collimators 204 comprising a combination of optical elements are appropriate for use in the column 200. For example, and without limitation, the collimator 204 may comprise two or more lenses or a lens and a reflective optic. The collimator 204 may further comprise an aperture configured to shape the charged particle beam. In certain embodiments, the collimator is adapted to direct the charged particle stream at accelerating potentials between about 5 and 30 kilo electron volts (keV). In certain embodiments, the exposure chamber 102 is adapted to direct the charged particle stream at accelerating potentials between about 5 and 500 keV. In some embodiments, a voltage of the collimator 204 is additive to additional voltages, for example applied by a lower column exit aperture.

[0064] In embodiments in which the charged particle source 202 is adapted to generate a plurality of ion species, individual ion species can be selected for specific processing applications by filtering the charged particle stream with a particle filter (e.g., a spectrometer filter). For example, a mass separator can be configured to deflect selected ion species into a mass separator aperture plate. The mass separator is preferably disposed between the collimator 204 and the beam digitizer 206. In some embodiments, the mass

separator comprises a reflective optic. In some embodiments, the mass separator comprises an ExB lens. In some embodiments, the mass separator comprises a Wein filter.

[0065] The beam digitizer 206 is configured to create a digital beam comprising discrete groups of at least one charged particle by adjusting the longitudinal spacing between charged particles along the axis of propagation. In certain embodiments, the beam digitizer 206 is configured to create groups comprising between about 1 and 7,000,000 charged particles, between about 1 and 100,000 charged particles, between about 1 and 10,000 charged particles, or between about 1 and 50,000 charged particles. In some embodiments, the beam digitizer 206 is configured to create longitudinal spacing D between groups of charged particles of less than about 10 m of beam travel, less than about 1 m of beam travel, less than about 10 cm of beam travel, less than about 10 mm of beam travel, less than about 1 mm of beam travel, less than about 500 μm of beam travel, less than about 300 μm of beam travel, less than about 100 μm of beam travel, less than about 10 μm of beam travel, less than about 100 nm of beam travel, less than about 10 nm of beam travel, or less than about 1 nm of beam travel between the groups of charged particles. In some embodiments, the beam digitizer 206 is configured to create longitudinal spacing between the groups of charged particles of between about 1 nm and 10 m of beam travel, between about 1 nm and 1 m of beam travel, between about 1 nm and 10 cm of beam travel, between about 1 nm and 10 mm of beam travel, between about 1 nm and 1 mm of beam travel, between about 1 nm and 500 μm of beam travel, between about 1 nm and 300 μm of beam travel, between about 1 nm and 100 μm of beam travel, between about 1 nm and 10 μm of beam travel, between about 1 nm and 100 nm of beam travel or between about 1 nm and 10 nm of beam travel. The longitudinal spacing between the groups of charged particles may be substantially equal, unequal, periodic, harmonic, etc.

[0066] In certain embodiments, the beam digitizer 206 comprises a beam buncher. In a radio frequency (RF) beam buncher, a stream of charged particles pass through a buncher gap where they are acted upon by an alternating potential, RF or multiple modulating potential wave forms, beat wave, harmonic, variable, or a combination thereof. Velocity modulation compresses the charged particles together so that they form spatially and temporally resolved discrete groups of charged particles. In certain embodiments, the

frequency and the buncher gap length are configured to match a mean velocity of the groups of charged particles. The applied potential modulates the longitudinal velocity of each charged particle as they pass through the buncher gap so that some charged particles (e.g., charged particles with a lower velocity than the mean velocity) are accelerated while other charged particles (e.g., charged particles with a higher velocity than the mean velocity) are decelerated (e.g., as depicted in Figure 3B). The gap length of the buncher gap, the magnitude and frequency of the applied potential, and the time of flight (TOF) of the charged particles through the column 200 determine the final characteristics of the digital beam and the groups of charged particles at the surface of the workpiece 101.

[0067] Figure 3C schematically depicts a stream of charged particles traveling through a beam buncher. A potential can be applied across the electrodes 302, 304 of the beam buncher that are separated by buncher gap G . If unaltered thereafter, the charged particles begin to form groups whose length L and separation (spacing) D depend on how far the charged particles have traveled after passing through the beam buncher. In some embodiments, the beam buncher is configured to compress the charged particles into groups during travel. In some embodiments, the beam buncher is configured to apply an electric field to longitudinally compress the groups of charged particles. The charged particles are preferably fully compressed in the longitudinal direction when they reach the workpiece 101 (e.g., as depicted in Figure 3C). The energy applied by the buncher can be determined by the difference between the initial energy of the stream of charged particles and the final energy of the temporally and spatially resolved groups of the charged particles.

[0068] In certain embodiments, the beam buncher comprises a plurality of buncher electrodes and therefore a plurality of buncher gaps. The potential can be selectively applied across two of the electrodes in order to change the characteristics of the digital beam. For example, a potential can be applied across electrodes with a buncher gap G of 1 μm to create nodes with a lower charged particle density and applied across electrodes with a buncher gap G of 3 cm to create nodes with a higher charged particle density.

[0069] The relationships between beam buncher input parameters such as beam energy and buncher current, frequency, and gap length and beam buncher output characteristics such as separation D , length L , and density are well known. The beam

buncher is preferably operated to provide a given number of charged particles per group. First, the buncher gap, frequency, and beam energy can be held constant while the current is adjusted. Second, the beam energy and buncher current can be held constant while the buncher gap and frequency are adjusted. Other operation configurations are also possible.

[0070] In some embodiments, the beam buncher comprises a helical coil that is modulated with a current frequency, resulting in a magnetic field. The longitudinal spacing (“gap”) between turns of the coil, the magnitude and frequency of the applied current, and the time of flight (TOF) of the charged particles through the column 200 determine the final characteristics of the digital beam at the surface of the workpiece 101. In certain embodiments, the frequency and longitudinal spacing between turns of the coil are configured to match a mean velocity of the digital beam.

[0071] Bunching charged particles allows write strategy optimization with dose variations at the charged particle level by varying the beam buncher frequency, amplitude, and duty cycle, which in turn varies the charged particle density, as described above. The beam buncher parameters are therefore preferably adjusted according to the write strategy.

[0072] In certain embodiments, the beam digitizer 206 comprises a beam blanker (e.g., a beam blanker that can operate at speeds sufficient to create a digital beam). For example and without limitation, the high speed blanker may comprise an aperture plate configured to absorb the charged particle beam at certain intervals. The aperture plate is initially positioned such that the stream flows through the aperture in the aperture plate proximate to an interior edge of the aperture plate. An electrode is configured to deflect the stream into the aperture plate, which intercepts the flow of particles to create a temporally and spatially resolved digital beam. Figure 3D schematically depicts a stream of charged particles traveling through a high speed blanker. An aperture plate 316 is positioned proximate to the stream of charged particles. The electrodes 312, 314 are configured to apply a potential to the charged particle stream to create temporally and spatially resolved groups of charged particles of the digital beam. If unaltered thereafter, the charged particles continue to travel with length L and separation D regardless of how far the charged particles have traveled after passing through the high speed blanker.

[0073] Other embodiments of the beam digitizer 206 are also possible. In some embodiments, the beam digitizer 206 is configured to modulate an on/off state of the charged particle source 202. In some embodiments, the beam digitizer 206 is configured to modulate a position of the charged particle source 202 longitudinal to the axis so as to displace the groups of charged particles.

[0074] In some embodiments, the beam digitizer 206 is configured to apply electromagnetic radiation, for example with a frequency of between about 1 megahertz (MHz) and 100 gigahertz (GHz) or between about 1 MHz and 25 GHz. In such an embodiment, the beam digitizer 206 can be configured to modulate, for example, the amplitude of the electromagnetic radiation, the frequency of the electromagnetic radiation, combinations thereof, and the like. In some embodiments, the beam digitizer 206 is configured to apply a beat wave to a plasma comprising the charged particles. In some embodiments, the beam digitizer 206 is configured to apply space charges to wake fields. In such embodiments, the beam digitizer 206 can be configured to resonantly absorb the space charges. In some embodiments, the beam digitizer 206 is configured to blank the beam through an absorption aperture. In some embodiments, the beam digitizer 206 is configured to apply a pulsed incident neutralizing beam to the charged particle source 202. In some embodiments, the beam digitizer 206 is configured to apply a pulsed laser beam to the charged particle source 202.

[0075] In certain embodiments, components described herein are advantageously combined. In an embodiment, the column 200 comprises a beam blanker downstream of the collimator 204 and a beam buncher downstream of the beam blanker. A digital beam coming from the beam blanker and into the beam buncher can be used to further temporally and spatially resolve the individual groups in the digital beam. In another embodiment, the column 200 comprises a beam buncher downstream of the collimator 204 and a beam blanker downstream of the beam buncher. Other configurations are also possible.

[0076] The column 200 further comprises a deflector 210 downstream of the beam digitizer 206. The deflector 210 comprises a series of deflection stages (e.g., electrode stages, magnetic stages) disposed longitudinally along the axis of the digital beam. The deflector 210 deflects individual groups of charged particles in the digital beam. As used

herein, the phrase “minor field deflection” refers to the deflection of an individual group of charged particles by the deflector 210. In some embodiments, the deflector 210 is configured to deflect the groups in the digital beam substantially perpendicularly to the axis of propagation. In certain embodiments, the deflector comprises between about 1 and 1,000 or four deflection stages. In certain embodiments, the deflector comprises at least one, two, three, or four deflection stages. In some embodiments, each deflection stage comprises two or more electrodes. In some embodiments, one or more deflection stage comprises four electrodes. Other quantities of deflection stages and electrodes are also possible.

[0077] In certain embodiments, an average or mean velocity of the groups of charged particles in a digital beam is between about 1×10^4 meters/second (m/s) and 3×10^8 m/s. In some embodiments, application of potentials by each of the deflection electrode stages is adapted to be synchronized with the mean velocity of the groups of charged particles passing through the deflector. For example, a deflection electrode stage may be adapted to apply a voltage only when a group of charged particles is passing through the deflector in general and through that particular deflection electrode stage in particular. In some embodiments, application potentials by each of the deflection electrode stages is adapted to be harmonically synchronized with a mean velocity of the groups of charged particles passing through the deflector. For example, each deflection electrode stage in at least a portion of the deflector may be adapted to apply a voltage only when a particular group of charged particles is passing through the deflector in general and through that particular deflection electrode stage in particular. In some embodiments, application of potentials by each of the deflection electrode stages is adapted to be randomly synchronized with a mean velocity of the groups of charged particles passing through the deflector. As used herein, the phrase randomly synchronized is to be given its broadest possible meaning including, but not limited to, synchronization of application of voltage by the deflection electrode stages to groups of charged particles with random spacing or synchronization of application of voltage by random deflection electrode stages to groups of charged particles with random or other spacing.

[0078] In certain embodiments, electrodes of the deflection stage apply a substantially equal voltage potential as each group of charged particles of the digital beam

passes. The amount of deflection of each group of charged particles depends on the number of electrodes activated sequentially. In some embodiments, variable potentials are applied to each deflection electrode stage as each group of charged particles passes. For example, the first deflection electrode stage has the smallest voltage with subsequent electrodes have progressively more voltage, resulting in a linear deflection as electrodes are activated. The converse is also possible, where the first deflection electrode stage has the largest voltage with subsequent electrodes having progressively less voltage. The number of deflection electrode stages activated defines the amount of deflection of each group of charged particles of the digital beam. The signal timing and nominal voltages applied to the deflector can be calibrated for individual deflection electrode stages and even individual electrodes within each deflection electrode stage. Triggering an applied voltage of individual deflection electrode stages can be delayed if needed to match the incidence of to each group of charged particles of the digital beam ("phase-matching"), for example due to changes in charged particle velocity, species, and mass, deflection stage position, pattern resolution, pattern field errors, errors within an objective deflection field, process specific compensation and write strategies, combinations thereof, and the like. In certain embodiments, a field perimeter of the deflection electrode stages is defined as the minor deflection field of less than 4 mm, less than 2 mm, less than 1 mm, or less than 100 μm displacement in x or y from the center of the axis of propagation.

[0079] In certain embodiments, the potentials of each of the deflection electrode stages are adapted to partially displace the groups of charged particles towards an intended trajectory. Each group is partially deflected $1/N$ th of an intended deflection distance by each of a number N of deflection electrode stages. In certain embodiments, the first deflection electrode stage, or any single deflection electrode stage, is adapted to substantially fully displace one or more (e.g., all) groups of charged particles towards an intended trajectory, and the other deflection electrode stages are used to fine tune the deflection of the groups. Other combinations are also possible.

[0080] In some embodiments, for example the harmonically synchronized deflector described above, at least a portion of the deflector comprises N sets of deflection electrode stages, each set of deflection electrode stage comprising N deflection electrodes, in

which every Nth deflection electrode stage is configured to displace a particular group of charged particles towards an intended trajectory. If at least a portion of the deflector comprises two sets of deflection electrode stages, every other deflection electrode stage in the sets of deflection electrode stages may be configured to displace a particular group of charged particles towards an intended trajectory. If at least a portion of the deflector comprises three sets of deflection electrode stages, every third deflection electrode stage in the sets of deflection electrode stages may be configured to displace a particular group of charged particles towards an intended trajectory. Other variations and configurations are possible.

[0081] Figure 6A depicts a top schematic view of a deflector 210 comprising at least one electrode in each deflection electrode stage. The digital beam comprising charged particles is configured to flow through the center aperture of the deflector 602. The sets of electrodes 604, 606 and 608, 610 may be positively or negatively charged such groups of charged particles are deflected perpendicularly to the longitudinal axis of the deflector and the path. Preferably, the electrodes on opposing sides, for instance, electrodes 604 and 606, are oppositely charged. Figure 6B is a perspective quarter cut-away view of the upper right quadrant of the deflector 210. The electrodes 606 are separated in this embodiment by an insulator 612. Examples of insulator materials include Al_2O_3 , SiO_2 , SiN_x , SiO_xN_y , combinations thereof, and the like. It will be understood that rather than a single deflector comprising a plurality of deflection electrode stages, the deflector 210 may comprise a series of deflectors, each comprising one or more deflection electrode stages. For example, a deflector 210 may comprise three sets of deflectors. As illustrated in Figure 6B, the groups of charged particles are deflected by each deflection electrode stage as they travel along the path. Other deflector and electrode configurations are possible.

[0082] In certain embodiments, the deflector 210 is configured to arrange the groups of charged particles into a three-dimensional timespace (an “adaptable virtual digital stencil”). In certain embodiments, the deflector 210 is adapted to create a laterally distributed pattern of the groups of charged particles. In some embodiments, the deflector 210 further comprises a deflector lens adapted to demagnify the pattern or the virtual stencil. The deflector lens may comprise an electrostatic lens, an electromagnetic lens, a reflective lens, a combination reflective and refractive lens, a combination reflective and deflective lens, a

combination deflective and refractive lens, combinations of the same, and the like. Figure 7 is a schematic block diagram of a column 200 in which the groups of charged particles coming out of the deflector 210 are arranged in a virtual digital stencil 702, each group of charged particles having undergone a minor field deflection. The objective lens assembly 212 is configured to deflect the virtual stencil with a major field deflection. The combination of minor field deflection, major field deflection, and movement of the workpiece 101 can be used to expose a pattern of charged particles on the workpiece 101.

[0083] In certain embodiments, a phase of the groups of charged particles of the digital beam longitudinal to the axis is configured to be substantially equal, single harmonic, multiple harmonic, random, combinations thereof, and the like. The spacing between the deflection stages may be adapted to be synchronized and to be in phase with the groups of charged particles. In some embodiments, longitudinal positions of the deflection electrode stages are adjustable. In some embodiments, the deflector 210 comprises a digital feedback system, for example to adjust the spacing between the deflection electrode stages. Piezos, etc. may be used to position the electrodes or deflection stages.

[0084] In some embodiments, the column 200 further comprises an objective lens assembly 212 disposed between the deflector 210 and the workpiece stage 214. The objective 212 may comprise a lens, a mirror, a reflective optic, a combination reflective optic and refractive lens, a combination reflective optic and deflection electrodes, a combination deflection electrode and refractive lens, combinations of the same, and the like. In some embodiments, the objective lens assembly 212 comprises a demagnifying lens assembly or a deflector electrode assembly configured to demagnify, focus, and/or deflect the groups of charged particles or the adaptable virtual digital stencil. For example, in certain embodiments and without limitation, groups of charged particles having a diameter (or “spot size”) of about 200 nm are reduced 10 times to a diameter of about 20 nm. The objective lens assembly 212 may also be adapted to demagnify the groups or the stencil by 100 times or 1,000 times. In embodiments in which the objective lens assembly 212 is configured to deflect a virtual digital stencil, the deflection may be called a “major field” deflection. In some embodiments, a field perimeter of the objective lens assembly 212 is defined as the major deflection field of less than 10 mm, less than 5 mm, less than 1 mm, or less than 100

μm displacement in x or y from the center of the axis of propagation. In certain embodiments, the exit aperture comprises an exit aperture.

[0085] Referring again to Figure 2, the exposure chamber 102 comprises a workpiece stage 214 downstream of the lower objective lens assembly 212. The workpiece stage 214 is configured to hold the workpiece 101. Preferably, the workpiece stage 214 comprises an interferometric stage, wherein the relative position of the stage is measured using optical interference. The workpiece stage 214 may be thermally controlled to reduce magnification errors in the workpiece, which can lead to overlay errors. The workpiece stage is preferably configured to continuously move while a workpiece 101 is exposed to the groups of charged particles. For example, the workpiece stage 214 may be configured to move continuously over a dimension of 25 centimeters over a period of 1 second during exposing. For another example, the workpiece stage may be configured to move without stopping for more than 5 nanoseconds per 0.5 seconds during exposing. The ability to continuously expose while moving the workpiece stage 214 without stopping can yield increase efficiency and throughput.

[0086] In certain embodiments, the workpiece stage 214 comprises an interferometer configured to determine the location of the workpiece stage 214 in a horizontal plane. The relative x/y position of the stage can be measured using optical interference. Other methods are also possible, for example the workpiece stage may comprise a registration mark, grid, or feature detectable by a secondary ion mass spectrometer (SIMS), backscattered electronics, or faraday cup disposed below the registration grid. The registration mark is preferably included in an assembly that can be moved parallel to the column 200 in order to optimize a working height of the registration mark to the workpiece, thereby reducing column calibration and registration errors. The digital beam may periodically or randomly be directed towards the registration mark to check the alignment of the column. The registration mark may also be used to calibrate the column 200 before, after, and/or during exposing a workpiece.

[0087] In some embodiments, the chamber 102 further comprises a height control system that measures the height of the workpiece stage 214 and/or a registration mark. The height control system can include, for example, a laser and a plurality of detectors configured

to receive light emitted from the laser and reflected by the workpiece, the workpiece stage 214, and/or a surface that moves with the workpiece. The height control system can compensate for variation in the measured height of the workpiece stage by adjusting an elevation of the stage, for example by using electrostatic clamps, piezoelectric devices, etc. In some embodiments, the height control system is configured to compensate for height variations of less than 1 μm . Electrostatic clamping may be used to secure the workpiece to the workpiece stage 214 and to ensure adequate thermal contact and flatness of the workpiece.

[0088] Full motion writing (FMW) can eliminate the workpiece stage motion overhead time while exposing a workpiece. In FMW, the deflector 210 system is updated in real time to track the motion of the workpiece stage 214, thereby allowing the system to write patterns while the workpiece stage is in motion. Such a process preferably uses a high speed optical controller (e.g., laser) to track the position of the workpiece stage 214. For example, circuitry on the controller can convert Doppler-shifted laser deflection measurements into laser pulses that can be stored in a stage position register. Interferometry, laser deflection measurements, or other optical techniques can be used to track the position of the workpiece. Therefore, the throughput of lithography systems can be improved by reducing or eliminating nonexposure time during stage repositioning and settling sequences.

[0089] While exposing a workpiece, each deflection field center is defined by a window of opportunity (WOO). While the workpiece stage is in motion and a deflection field passes over an unwritten WOO, a stage controller signals a deflection controller to initiate exposure. The workpiece is exposed while the undeflected beam center passes through the WOO. Within the WOO, the deflection system can deflect to the outer limit of the field. During this time, the deflection system is updated by the workpiece stage position register of the actual location of the workpiece stage.

[0090] The workpiece stage can allow real time deflection correction. By changing the WOO size or frame size, or by smoothing the frame-by frame pattern data, the system can be dynamically optimized for continuous writing. A typical frame/WOO density is depicted in Figure 4A.

[0091] The workpiece stage may be configured to provide suitable velocity performance, for example at 100 centimeters per second. The workpiece stage may be configured to rotate a workpiece during exposure at up to about 40,000 rotations per minute (rpm). For example, the workpiece stage may have as little inertia as possible, and a compatible workpiece stage motor design can be provided. The use of vacuum compatible air bearing rails and linear motor drives can provide adequate decoupling of vibration sources. As additional examples, the workpiece stage motors can be placed in the vacuum system, light weight materials can be used for the workpiece stage, and the workpiece can be aligned on the stage, thereby eliminating the workpiece cassette and cassette clamping hardware. Additionally, the first three derivatives of stage position (velocity, acceleration, and jerk) can be limited and damped by electronic hardware to properly control the motion of the workpiece stage. Figure 4B is a schematic diagram of an example workpiece stage and control electronics.

[0092] The exposure chamber 102 may be in communication with control electronics, for example system support electronics 220 including wafer handler control, vacuum control, suspension control, temperature control, pressure control, etc. and column support electronics 230 including a source control module, digitizer control, deflector control, lens control, wafer height sensor, video processor, stage control, and a dynamic corrector (e.g., for real time column aberration correction). The column support electronics 230 may be in communication with data process electronics 240, for example a workstation.

[0093] An example application of the systems described herein is to perform *in situ* workpiece processing or resist exposure by directly writing on the workpiece. Preferably, accurate registration of optics to the target workpiece is achieved, but tool induced shift (TIS) and workpiece induced shift (WIS) errors may be introduced due to temperature effects, workpiece processing effects, and optical distortions. An example solution is to measure an initial pattern (e.g., one or more alignment marks) on the workpiece and to use the measurement data to accurately place a newly patterned image onto the workpiece, for example by adjusting the exposure parameters.

[0094] A registration sensor preferably can automatically detect and recognize a variety of registration and alignment mark patterns, materials, and profiles without impacting

the quality of exposure throughput. Examples to achieve such a sensor include, but are not limited to, using a high resolution, high speed registration system with existing hardware, determine the limitation and flexibility of the registration strategy (e.g., by mapping the workpiece with die-to-die registration) and the incorporating a temperature conditioning stage, and introducing a high speed moiré (grating) interferometer system for die-to-die registration, combinations thereof, and the like. Other approaches are also possible.

[0095] A high resolution, high speed registration system can employ existing hardware and can be similar to existing electron beam registration, but a plurality of imaging modes can be used. Scanning the surface of an object (e.g., a registration or alignment mark) with a digital beam produces secondary electron emission, secondary ion emission, and ion sputtering. A bi-axial or cylindrical microchannel plate can be used to detect both secondary electrons (e.g., by biasing above the voltage of the target) and the secondary ions (e.g., by biasing below the voltage of the target). Other configurations are also possible. An image can be created by measuring a signal yield of the secondary ions and secondary electrons at each point where the beam impacts the target. Variations in the yield indicate changes in surface topology or composition of the workpiece. The position resolution of this signal is a product of the measured beam spot size and deflection pixel size during registration and is augmented by statistical metrology. Sputtered ions provide greater mark recognition ability because such ions can be collected and mass analyzed secondary ion mass spectroscopy (SIMS). SIMS registration techniques are well developed and can be used both for mark detection and for process development diagnostics. An atomic map with the spatial resolution of the beam spot size can provide excellent precision for mark detection.

[0096] To optimize registration, a product summation of the detector video signal with a computer generated image of the registration or alignment mark can be used to enhance or recover an otherwise unrecognizable target signal from high-noise background. This can be performed by automatically correlating the video gain and bias offset for an initial signal enhancement. Once the tone is properly adjusted, the signal can be correlated with a computer generated (CAD) image of the registration or alignment mark to provide an enhanced image of the mark. Other signals are detectable from digital beam mark interaction. Signals such as those from secondary electrons and backscatter electrons may be

used for this process. Additionally, signals from secondary electrons and backscatter electron may be employed differentially to improve detection limits (e.g., signal to noise ratios). For example, the final detection signal may be the difference between SIMS and other signals. The speed of registration may be limited by the quality of the registration electronics, but incorporating modern electronics (e.g., digital signal processing (DSP)) may reduce the registration time by orders of magnitude without burdening registration resolution.

[0097] Another consideration in the quality and speed of registration is the configuration used to register to the workpiece prior to exposing. Depending on the pre-conditioned and in-process temperature stability of the workpiece, several strategies are available to compensate for distortions and throughput issues. Workpiece mapping generally registers a single die, providing reduced or minimum overhead to the system throughput but no correction for pattern distortion caused by temperature instability during exposing. Die-to-die registration performed immediately prior to die exposure, for example to minimize temperature distortion effects, generally uses four registrations per die per level. Such a technique eliminates the ability to write in a serpentine mode, drastically limiting the throughput of the system by memory load overhead time. However, performing registration on a plurality of dies at one time can maintain the ability to write in a serpentine mode within a field comprising the plurality of dies, thereby allowing increased or maximum throughput while reducing or minimizing pattern distortion.

[0098] Overlay accuracy becomes increasingly important as device geometries shrink. For a digital beam tool, the direct exposure of multi-level patterns on a single workpiece for manufacturing of integrated circuits desirably includes accurate intra-layer registration. An example workpiece alignment technique has three features: adequate signal generation from the surface impact of the digital beam; a detection algorithm for processing the detected signal; and an alignment feature fabrication technique.

[0099] The impact of a charged particle onto the workpiece can create media such as secondary electrons, backscattered electrons, photons, and secondary ions, each having certain advantages in detection efficiency. However, selection of a particular media for registration purposes depends on the charged particle species, the charged particle energy, and the current density of the beam. A signal detector may be optimized for a given media.

For example, an electron-photomultiplier is generally appropriate for secondary electrons, a solid state diode is generally appropriate for backscattered electrons, and secondary ion mass detectors are generally appropriate for photons and secondary ions.

[0100] A digital signal processor processes information from the signal detector in order to determine the location of the alignment mark. A traditional method of detection includes a one-dimensional line scan with the digital beam. As the digital beam transitions by deflection across the alignment mark, the detected video signal is modulated. Modulation occurs because differences in the alignment mark and the contour of the workpiece. Actual alignment mark location can be determined by processing the distribution of the modulated signal via a digital signal processing module. Another detection method includes an X/Y scanning mode of the digital beam to acquire a video image of the alignment mark. To achieve accurate edge detection, digital signal processing algorithms are applied. Improved detection of the alignment feature edge is accomplished through a two-dimensional imaging method that averages several frames of video data and determines the actual location of the alignment mark by gray scale signal processing.

[0101] Preferably, alignment marks are formed over the entire working area of the workpiece in the form of equally spaced two-dimensional grids. One construction method is the formation of a raised multi-layered semiconductor structure consisting of layers of silicon, silicon dioxide (SiO₂), and polysilicon, with an alignment mark formed on the polysilicon layer of the wafer. In another construction method, an alignment mark is etched into the surface of a silicon wafer and a layer of a heavy metal (e.g., tantalum or tungsten) is deposited into the trench. The alignment mark containing the heavy metal exhibit a high level of backscatter relative to a silicon substrate, thereby providing contour details for low energy backscatter ion detection. Selection of an appropriate alignment feature construction method depends on the signal media and the signal detector, dictated by process steps.

[0102] A minimum of three alignment marks are preferred in order to accurately identify translation, rotation, and magnification errors. The measured errors are fed back to the workpiece stage control system for correction, thereby reducing workpiece and tool induced shift errors. The processing of global alignment marks may permit faster and more accurate detection of localized alignment marks by removing gross errors. The alignment

process can be repeated whenever the workpiece is inserted into the exposure chamber, whenever the workpiece is removed from the apparatus, between significant process steps, etc. Other techniques can also be used.

[0103] Patterning tools transfer large quantities of microelectronic circuit pattern data in a format that can be manipulated (e.g., converted from digital to analog) within small periods of time (e.g., nanoseconds). The data is typically in a format for very large scale integration (VLSI) computer aided design (CAD), as described below. This data is used, for example, to control the deflection by the deflector 210, the deflector lens, the objective lens 212, and/or movement of the workpiece stage 214 and can be adjusted to address aberrations in the optics. Charged particle exposure chambers may have imperfections (e.g., aberration, deflection errors), for example due to manufacturing or installation imperfections and the physical constraints of the optics. As an example, if a system is installed with a slight rotation relative to the workpiece stage 214, beam deflections will be rotated relative to the motion of the workpiece stage 214. More complex errors may also be present; for example, an attempt to trace the outline of a large square with the beam may produce a pincushion or barrel shaped pattern. The magnitude of these effects is proportional to the magnitude of deflection of the digital beam, which can limit the size of the deflection field and can create nonlinear distortions in system writing quality. High resolution writing using a digital beam is therefore preferably able to augment transformed pattern data to compensate for deflection field distortion, wafer distorted pattern placement errors, stage position, etc.

[0104] Additionally, processing errors may be introduced. Pattern distortion or deflection distortion can result from several factors when exposing a workpiece with a digital beam. For example, thermal fluctuations in the exposure chamber 102 or in a workpiece 101 can cause magnification errors. For another example, securely clamping the workpiece 101 to the workpiece stage 214 can also cause rotational errors or can induce stresses resulting in pattern sheering. For yet another example, unrecoverable nonlinear pattern distortions can result from subsequent processing such as rapid thermal annealing. For still another example, manufacturing or installation of the optics may be imperfect (e.g., with a slight rotation relative to the workpiece stage) and the optics have certain physical constraints. More complex errors may be introduced by certain processes, for example and without

limitation, tracing a large square with the digital beam may result in a pincushion or barrel shaped pattern. The magnitude of the errors may be proportional to the magnitude of the beam deflection such that they can limit the size of the deflection field and can create nonlinear distortions in system writing quality. The adaptable virtual digital stencil is in softcode at any given point in time. As such, the stencil is temporally and spatially adaptable to correct in real time for nonlinear pattern offset, gain, rotation, and corrections within the minor field, while being deflected in the major field. These corrections can be performed within features, die, or to the entire workpiece.

[0105] Digital beam lithography systems preferably can perform pattern and beam corrections to compensate for processing-induced errors on the workpiece and optical errors (e.g., coma distortion, astigmatism, image pure distortion, chromatic aberration, spherical aberration, field curvature, etc.). Such corrections can improve writing quality and enhance system throughput.

[0106] Pattern and deflection distortion problems can be corrected by incorporating data manipulation bias electronics (hardware and software) into the system. For example, process control software can use metrology measurements to correct the deflection of the digital beam. Such metrology measurements preferably are made prior to exposing the workpiece. The quality of the digital beam may initially be optimized to provide improved or optimum measurements from subsequent metrology. In some embodiments (e.g., as depicted by Figure 4C), a knife-edged micromesh grid is placed over a diode detector, which is scanned by the digital beam. The second derivative of the beam current with respect to the scan position provides a high resolution beam profile (e.g., as depicted by Figure 4D). Optimization (e.g., automated optimization) of the beam profile with the optics control system allows focusing of the beam.

[0107] Once the digital beam has been optimized at small or minimum deflection angles, the system can correct the digital beam profile within a larger usable deflection field by moving the workpiece stage 214 to a plurality of positions within the outer limits of the distorted deflection field. The digital beam is then deflected to the position where the grid is scanned for beam optimization. The sequence is repeated over an extended size of the deflection field. Beam optimization data can then be correlated with an interferometer or

other position monitoring system of the workpiece stage 214. In certain embodiments, the linear contribution of the error is stored as an argument, while the nonlinear error is stored as pure memory. Beam distortions that depend on the position of a minor field within a major field can also be correlated. Within the minor field, use of the grid to calibrate deflection distortions can be performed without moving the workpiece stage by major field deflection of the adaptable virtual digital stencil to fit the scans on the grid. As a result, automated optimization or improvement of the beam profile can be performed within an extended deflection system, thereby allowing improved writing quality and throughput performance.

[0108] A final measurement can be made prior to exposing portions (e.g., individual dies) of the workpiece 101 because the workpiece 101 may be rotated or distorted as a result of temperature or stress effects caused by processing. If a pattern is being written on a workpiece 101 that already contains previous pattern levels, the new level can be adjusted to overlay on the previous levels, for example by registering to three or four corners of the die and then applying a magnification or rotational correction within each die. For example, the calibration software may automatically measure features on the edges of each die prior to exposure and use the measurements to correct for any pattern displacement, magnification, or rotation caused while aligning, processing, or handling the workpiece.

[0109] As described above, the exposure chamber 102 can be operated by providing integrated circuit (IC) design data, for example in the form of CAD schematics, to generate and expose the pattern on the workpiece. Users of the apparatus 100 input a desired pattern to be written, along any specific alignment configurations and/or processing parameters. Once the design for a device (e.g., an integrated circuit) is developed, multiple pattern layers of the design can be laid out to cover the workpiece as desired (e.g., to cover the entire workpiece). A complete exposure data preparation (EDP) package with a user interface can be used to convert raw designs (e.g., in CAD or graphic data system (GDSII)) to a format usable by the exposure chamber 102 (e.g., exposure ready format (ERF)). Prior to loading pattern data onto the system, several format changes, such as compressing and merging similar pattern features and reducing overlapping routines, can be made to increase or maximize throughput of the exposure chamber. Once the pattern data has been compressed to a reduced or minimum size, a field partition routine can define the major and

minor deflection fields of the pattern data and use a smoothing routine to normalize the density in each data frame. Normalization reduces stage jerking when writing repetitious adjacent multiple density patterns. After registration as described above, the pattern is laid out on the workpiece, using the registration data to calibrate the intended beam pattern to the actual workpiece pattern and to apply any compensation to improve overlay accuracy.

[0110] In various embodiments, for example pattern data in GDSII, OASIS, or other suitable formats is input into the system. The input data is then fractured into subfields and identified as to whether they are to be “written” or “non-written.” The mapping of the written subfields is sent to a data path module for rasterization (e.g., conversion to a bitmap). Throughput improvement is achieved by moving the workpiece stage and deflecting the beam from one written subfield to a non-adjacent written subfield without exposing non-written subfields. No time is spent processing non-written subfields without pattern data.

[0111] Various deflection technologies can be used to expose a workpiece to charged particles. Raster scan is a scanning mode in which the beam moves back and forth over the entire workpiece; the beam is turned on over designated areas and is turned off until the next designated area. Vector scan is a scanning mode in which the digital beam scans only selected areas where pattern is to be placed; after scanning of the selected area is completed, the beam is turned off and moved to selected area to be scanned. Hybrid vector-raster technology utilizes a vector approach for major field deflection between data pattern subfields and uses a raster scan technology to deflect a Gaussian or shaped digital beam within the subfield. Throughput improvement can result from only moving the workpiece stage to positions that receive exposure. Another form of vector-raster includes a vector deflection in the major field, a vector deflection between pattern features within the minor field, and a raster image of the feature within the minor field. The vector capability of a vector-raster system can provide higher throughput versus a pure raster scan system, and the raster capability of the vector-raster system permits good pattern fidelity and high current with a small dwell time.

[0112] As described above, in certain preferred embodiments, minor field deflection of the digital beam is accomplished through a deflector, which is possible because that the longitudinal spatial and temporal spacing of the groups of charged particles permits

the individual deflection of each group. In certain embodiments, the voltage applied to each deflection electrode stage is timed to match the velocity of each group of charged particles.

[0113] Spacing between groups of charged particles can effectively provide blanking. In particular, such blanking between groups effectively uses the full flux of a continuous or nearly continuous charged particle stream. The temporal spacing between groups allows for deflection error correction (error correction signal summing can compensate for stage disposition, deflection aberrations, optical aberrations, and write mode process adjustments). Throughput improvement can be achieved by maximizing the time that the digital beam exposes the workpiece.

[0114] In certain preferred embodiments, the digital beam is capable of performing a plurality of pattern exposure strategies. Such strategies may be designed to modify exposure dose, species, pattern quality, beam energy per group of charged particles, beam energy for sets of groups, and beam energy for an adaptable virtual digital stencil. The apparatus may also be capable of discretely modifying exposure dose, species, pattern quality, beam energy per group of charged particles, beam energy for sets of groups, and beam energy for an adaptable virtual digital stencil within a particular writing strategy to optimize that particular writing strategy for a particular process.

[0115] In an embodiment of a writing strategy, the beam is scanned in raster fashion across the entire area of the workpiece. In certain embodiments, the spot size of the beam is greater than the grid spacing in the raster (e.g., as depicted by Figure 21A). In certain embodiments, the spot size of the beam is substantially equal to the grid spacing in the raster (e.g., as depicted by Figure 21B). That is, the pattern is vector scanned in the major field, vector scanned in the minor field, and raster scanned in a single pass within the feature to be exposed. Feature processing with a digital beam can leverage the per pixel dose variation to improve feature edge quality when performing etch, implant, and deposition. In some embodiments, a digital beam spot size to pixel ratio greater than one can average placement of the groups of charged particles and can reduce exposure process errors. A large digital beam spot size to pixel ratio improves line edge roughness and allows a higher dose deposition due to cumulative dosing from overlapping beams. This process can also be performed with or without resist.

[0116] In another embodiment of a writing strategy, alternating row and column exposure is performed with a large spot size and small pixel size ratio. Exposing alternating pixels with a digital beam produces a pixel exposure width half as wide as the selected feature, thereby increasing the feature critical dimension over target value in both axes (e.g., as depicted in Figure 21C). That is, the pattern is vector scanned in the major field, vector scanned in the minor field, and raster scanned in alternating pixels in both x and y directions with a single pass within the feature to be exposed. Throughput is increased by effectively reducing the number of charged particles per flash, but at the cost of critical dimension control. There are advantages to using this write mode for a digital beam, such as the ability to apply per pixel dose variation or multiple species exposure to improve device performance, feature edge quality, and throughput when performing resistless etch, implant, and deposition processes. The throughput improvement can be dramatic since system throughput increases as the square of the effective writing grid. This process can be performed with or without resist.

[0117] Yet another embodiment of a writing strategy divides pixel spaced matrices (or "composites") and overlays exposure of a combination of composites interleaved in a series of passes, with each pass offset from other passes in both the x and y directions by a fraction of the writing address. That is, the pattern is vector scanned in the major field, vector scanned in the minor field, and raster scanned in a series of passes that interleave the pixels within the feature to be exposed. The beam size can be set 25-100% larger than pixel size in order to average out the flashes and to reduce the number of charged particles per group (e.g., as depicted in Figure 21D). A larger beam spot size versus pixel size helps reduce line edge roughness by averaging systematic errors to allow a higher dose deposition (e.g., as depicted in Figure 21E). There are advantages to using this write mode for a digital beam, such as the ability to apply per pixel dose variation to improve feature edge quality when performing direct etch, implant, and deposition processes, thereby improving feature edge quality. This process can also be performed with or without resist. The feature quality is improved, but multiple passes are achieved with little or no effect on throughput.

[0118] Yet another embodiment of a writing strategy leverages a sampling matrix having an array of cells of a predetermined input address size. Each pass produces a writing

grid defined by the distance between beam placements in a single pass. That is, the pattern is vector scanned in the major field, vector scanned in the minor field, and raster scanned in a series of passes offset in the x and y directions to create multiple offset composite feature patterns that interleave the pixels within the feature to be exposed. The composite of all passes forms the effective exposure grid (e.g., as depicted in Figure 21F). The dose of the beam can also be freely varied within the operating envelope of the system. There are advantages to using this write mode for a digital beam, such as the ability to apply per pixel dose variation to improve feature edge quality when performing resistless etch, implant, and deposition processes, thereby improving feature edge quality. This process can also be performed with or without resist with a pixel rate greater than about 400 MHz. A good balance between feature quality and throughput can thereby be achieved. The dose of the beam can also be varied within the process-defined operating envelope of the system (e.g., as depicted in Figure 21G). This can be performed with a number of techniques including modulating the duty cycle of a beam buncher. Multiple levels of pixel intensity are provided from 0% to 100% beam intensity. Pixels of partial intensity are used along the edge of a feature so as to locate the edge between the lines of a Cartesian raster scan grid. The dose modulation can be assigned by the user via the pattern data file. There are advantages to using this write mode for digital beam processing, such as the ability to apply per pixel dose variation to improve feature edge quality when performing resistless etch, implant, and deposition processes, thereby improving feature edge quality. This process can also be performed with or without resist. A good balance between feature quality and throughput can thereby be achieved.

[0119] Figure 8 illustrates an example vector-raster write strategy using a digital beam. The workpiece is divided into square pixels 1 through 44. The beam generally writes in a serpentine motion across the workpiece, from 1 to 4, then from 5 to 12, then from 13 to 22, etc. Each pixel is divided into stripes, and each stripe is divided into fields, which are divided into subfields. The beam generally writes in a serpentine motion across each stripe, field, and subfield as well. Within each subfield, the beam is able to write only where written features exist. Like vector scanning, the digital beam only scans selected areas, but the beam does not need to be turned off to be moved to another area, at least the time the beam is

turned off is reduced as the dead space between the groups of charged particles can be used for that purpose.

[0120] As device geometries decrease, patterning with accurate overlay is preferably at least one order of magnitude smaller than the minimum or critical dimension. Workpiece processing and handling may induce pattern errors across the workpiece that contribute to placement errors, especially as geometries fall below 0.25 microns. However, serial patterning equipment (e.g., exposure chambers with a digital beam) has the flexibility to correct for these errors by registration and pattern data augmentation. A fully automated metrology program that commands the digital beam to align itself, perform deflection/workpiece positioning calibration, and recognize and correct for wafer pattern distortion can eliminate not only pattern defects at the most recent level, but for other pattern errors, as well.

[0121] As previously discussed, beam measurement and laser interferometer systems have accuracies to within a few angstroms. Making use of these measurements, system calibration software can collect the deflection gain, linearity, offset, and rotation for both the major and minor deflection fields. The deflection is calibrated to the laser interferometer system, providing a well-behaved deflection motion and profile of the digital beam within the deflection field. Linear and nonlinear errors of the digital beam profile with respect to the beam deflection can also be measured and corrected. Because each die is registered prior to exposure, temperature compensation can be performed by adding corrections to the pattern software and exposing that die in a corrected state, which allows the system to reduce or eliminate pattern distortions caused by annealing, vacuum radiation drain and evaporation, and improper conditioning.

[0122] The flexibility of electronic data preparation (EDP) software allows alterations of the pattern to accommodate processing variability. Pattern editing, tone reversal, and feature biasing provide increased flexibility to the user of the apparatus 100. In addition, feature bordering, dose by size, and dose by type can improve digital beam assisted chemical etching (DBACE) and digital beam nucleation deposition (DBND) at small geometries.

[0123] Preferably, a data manipulation bias system corrects for pattern and deflection distortion, for example by augmenting pattern data applying corrected data to the optics control system. The data manipulator system applies final pattern data biasing prior to optics control, and therefore may include very fast electronics (e.g., the fastest electronics in the system). This system sums pattern data correction, deflection distortion correction, and workpiece stage motion correction to the front end of the optics control system. Digital to analog converters at the front end of the optics control system convert the digital signals from the data manipulator. Once amplified, these analog signals drive the column 200.

[0124] Overlay accuracy can limit sub-micron lithography. For example, traditional lithography systems cannot correct for nonlinear pattern distortions caused by wafer processing, which is exacerbated by increased workpiece sizes and reduced device geometries. However, certain digital beam systems described herein can advantageously correct for such errors because the pattern is not fixed on a reticle, but can change during exposing. The adaptable virtual digital stencil is in softcode at any given point in time. It is therefore temporally and spatially adaptable to correct in real time for nonlinear pattern offset, gain, rotation, and corrections within the minor field, while being deflected in the major field. These corrections can be performed within features, die, or to the entire wafer.

[0125] A method of processing a workpiece 101 in the exposure chamber 102 comprises exposing the workpiece 101 to a digital beam of charged particles. In certain embodiments, exposing the workpiece 101 comprises forming a stream of charged particles, collimating and propagating the stream along an axis, digitizing the stream into a digital beam comprising groups (or packets or flashes) comprising at least one charged particle, deflecting the groups of charged particles using a series of deflection electrode stages disposed longitudinally along the axis, demagnifying the pattern, and focusing the demagnified pattern of groups of charged particles onto the workpiece 101. The dosage of exposure is preferably less than about 1×10^{17} charged particles/cm². As described above, digitizing the beam may comprise, for example, beam bunching, high speed blanking, combinations thereof, and the like.

[0126] In some embodiments, deflecting the groups of charged particles comprises selectively applying voltages across the deflection electrodes at each deflection

electrode stage. Selectively applying the voltages may comprise applying a large voltage with a first deflection electrode stage and applying smaller voltages with other deflection electrode stages. Selectively applying the voltages may also comprise applying a small voltage with a first deflection electrode stage and applying larger voltages with other deflection electrode stages. Selectively applying voltages may also comprise applying approximately equal voltages at each deflection electrode stage. Demagnification of the groups of charged particles preferably produces packet diameters of less than about 200 nm, less than about 50 nm, less than about 10 nm, less than about 5 nm, or less than about 1 nm. The workpiece stage may move continuously during the exposing process. For example, the workpiece stage may move continuously over a dimension of about 100 cm over a time period of 1 second. For another example, the workpiece stage may move without stopping for more than 5 nanoseconds per 0.5 seconds.

[0127] Figure 5 illustrates a plurality of groups of charged particles 502, 504. In some embodiments, deflection of a group of charged particles occurs during a dead zone 512 at the workpiece such that no exposing occurs during the deflection. The rise time 509 of saturated beam pulses can be used for blank and unblank edges. In some embodiments, the geometry of the groups of charged particles are Gaussian in x and y dimensions perpendicular in time, as well as Gaussian in velocity to, the axis of propagation. In some embodiments (e.g., as depicted in Figure 5), the groups of charged particles 502, 504 have a trapezoidal cross-section along the longitudinal axis. In Figure 5, two groups of charged particles 502 and 504 are depicted. Each digital beam has a density distribution rise time 506 and a fall time 508. The time between no charged particles and the peak density of charged particles is the quick pulse rise time 509. The time in which each group 502, 504 has a peak density of charged particles is the digital flash time 510. The time between the full concentration of charged particles and no charged particles is the quick fall time 511. The time in which there are no charged particles is the dead zone 512 (the anti-node region). The time between the last instance of a full concentration of charged particles in a first group, for example the group 502, and the initial concentration of charged particles in a subsequent group, for example the group 504, is the deflection time 514. The time between the first concentration of charged particles in a first group, for example the group 502, and the initial concentration

of charged particles for a second subsequent group, for example the group 504, is the flash duty cycle (or “flash spot rate”) 516 and is used for feature-to-feature deflection time within the minor field. In some embodiments, however, blanking can occur over multiple duty cycles. A blanker may be used.

[0128] Referring again to Figures 1A and 1B, the apparatus 100 may further comprise at least one dedicated process chamber 108. Additional process chambers can optionally be used for advanced processing. The process chambers 108 may comprise any variety of workpiece processing equipment. For example, and without limitation, the processing chambers 108 may comprise etch, deposition (e.g., oxidation, nucleation, etc.), rapid thermal anneal (RTA), combinations of the same, and the like. Some process chambers 108 may be configured to process a workpiece 101 that has been exposed in the exposure chamber 102, while other process chambers 108 can be configured to process a workpiece 101 before or after processing in another process chamber 108, before processing in the exposure chamber 108, etc. In certain embodiments, a process chamber 108 does not substantively change the workpiece 101. For example, a process chamber 108 may comprise a calibration or metrology tool. In certain embodiments, the apparatus 100 comprises a plurality of processing chambers 108 such that a workpiece 101 may be transformed from a bare substrate to a substantially finished product. Preferably, workpiece 101 can be fully processed without being removed from the apparatus 100. In certain embodiments, the duration from starting substrate to substantially finished product is less than one week, more preferably less than two days, or even more preferably less than one day, or more preferably yet in less than one hour.

[0129] In an example embodiment, two process chambers 108 are dedicated to nucleation and oxidation deposition, a third process chamber 108 is dedicated to rapid thermal annealing, and a fourth process chamber 108 is dedicated to chemically-assisted digital beam etching (CADBE). Although one process chamber 108 may be adapted to perform all such processes, dedication allows, for example, the use robust materials to avoid corrosion in the CADBE chamber.

[0130] Automated processing software can be used to monitor and analyze all aspects of the system’s performance, to perform automation control of all functional

operations, and to optimize each process performed by the system. The software can perform a data gathering routine on all sensors of the system and organize the results into operational and performance related reports addressing the status of the system. The software can also prepare a processing report for each workpiece processed through the system including the targeted process compared to the actual process, which can be used to determine fault analysis and process boundaries. Feedback of the process parameters into an automated control loop (e.g., a knowledge based routine) allows high leverage in developing processes. The software may incorporate data gathered from one or more metrology processes to enhance such process development, for example to monitor and adjust etching rates, deposition thicknesses, and contamination. The software can preferably operate all system functions, including process sequences, process parameters for each sequence, etc., although pattern exposure may be controlled by a pattern generation system. The software can produce interlocks based on the process sequences and can provide full automation and optimization of the processes. Other configurations are possible. User control and adjustment is also used in certain embodiments.

[0131] Etching is a process for the manufacture of semiconductor circuits. High leverage microelectronic integrated circuits generally utilize high resolution etching of materials to within a critical dimension and location. The ability to etch metals, semiconductors, and dielectrics with precise control over feature depth, uniformity, anisotropy, and reproducibility is desirable for many applications. Standard processing techniques typically utilize a resist-related patterning step followed by a wet or dry chemical etch to perform material removal.

[0132] Resist patterning limits the quality of the etch process profile, size, depth, and uniformity. Milling, or etching after exposure by a focused ion beam, provides high resolution removal of material without the use of resist. However, high dose and low sensitivity cause slow speed of the equipment, and milling has not been commercially successful. Chemically assisted processes (e.g., chemically assisted ion beam etching (CAIBE) and reactive ion etching (RIE)) were introduced to enhance milling, but they could not be incorporated into FIB equipment because the gas reacted with several components within the exposure chamber. In contrast, as described herein, low dose procedures in

combination with concentrated charged particles in groups compatible with resistless processing provides quality patterns and high throughput.

[0133] In certain embodiments, etch, implant, and deposition of the workpiece can be performed within the exposure chamber 102. Multiple activation by exposure to a digital beam and a process gas can dramatically improve the efficiency of all three processes. A digital beam specifically designed for a particular process in terms of energy, species, and current, which is possible because the digital beam parameters are adjustable, can impact and decompose a portion of the process gas molecules. The decomposed molecules strike surface atoms of the workpiece to sputter or implant new atoms into the workpiece, or to deposit new atoms on the workpiece surface. In some embodiments, portions and/or all of the workpiece is heated during exposing.

[0134] A new family of etching techniques is ideally suitable for high resolution, high throughput microelectronics manufacturing using a resistless process. This new process family is called digital beam assisted chemical etching (DBACE), and is up to 10 to 100 times more sensitive to ion exposure than milling. The process comprises at least two steps including digital beam exposure of a pattern to the regions to be etched. The target surface of a workpiece is exposed to very low dose ion energy, creating a reactive region for the chemical agent. The workpiece is then introduced to reactive gas within a separate chamber. As a result, a high resolution dry chemical etching process actively removes the material within the desired location as a parallel process to digital beam pattern exposure on other workpieces within the exposure chamber. As an example, DBACE can be performed on silicon and silicon dioxide (SiO_2) with chlorine (Cl_2) or fluorine (F_2) gas, on gallium arsenide (GaAs) with Cl_2 , on carbon (e.g., diamond) with oxygen (e.g., O_2) and nitrous oxide (N_2O_3), on tungsten and molybdenum with carbon bromine trifluoride (CBrF_3) and high temperature superconductors (e.g., cuprates such as $\text{La}_{1.85}\text{Ba}_{0.15}\text{CuO}_4$, $\text{YBa}_2\text{Cu}_3\text{O}_{7-x}$ (yttrium barium copper oxide, YBCO, Y123, yttrium barium cuprate), and cuprate-perovskite ceramics with or without normal metallic regions) with wet hydroxide chemicals (e.g., sodium hydroxide (NaOH), potassium hydroxide (KOH)). DBACE has been successfully applied to etch the gate recesses of gallium arsenide field effect transistor (FET) devices without destroying the underlying active device region.

[0135] Figures 9A-9C schematically illustrate an example digital beam assisted chemical etching process. In Figure 9A, an oxide layer 902 has been deposited over gallium arsenide. In Figure 9B, the oxide layer 902 is exposed in an exposure chamber 102, for example with gallium ions (Ga^+), depicted as arrows 904. The workpiece is then transferred to an etchant chamber. In Figure 9C, a chlorine (Cl_2) etch removes the oxide layer that was exposed in the exposure chamber 102, as well as underlying gallium and arsenic as gallium chloride (GaCl_2) and arsenic chloride (AsCl_2), respectively. The result is a trench in the gallium arsenide, as depicted in Figure 9C. It will be appreciated that other ion species and etching species may be selected depending on the material or materials to be etched.

[0136] The deposition of thin films has been a staple process in microelectronics fabrication. Many techniques have been used to deposit thin films, including thermal and electron-beam evaporation, physical vapor deposition (PVD) (e.g., sputter deposition), chemical vapor deposition (CVD), atomic layer deposition (ALD), plating (e.g., electroplating and electroless plating), and coating (e.g., spin coating). In conventional fabrication, these techniques normally deposit material on an entire surface of a workpiece, and the material is formed into patterns by a liftoff or milling process using a resist patterning process. Due to the cost, complexity, and physical limitations of resist patterning processes, other non-resist techniques are generally preferred in semiconductor processing. Deposition techniques that may advantageously avoid resist patterning processes by exposure to a particle beam before, during, or after the application of a deposition process include particle beam and thermally activated deposition, for example, but not limited to, digital beam activated CVD, digital beam activated thermal nucleation, digital beam activated ALD, and chemically-assisted digital beam deposition.

[0137] Two examples of direct pattern deposition are ion beam nucleation deposition (IBND) and chemically assisted ion beam deposition (CAIBD). Both techniques decompose or nucleate atoms on the surface of a workpiece, but can be limited by slow beam writing techniques. CAIBD is described above with respect to advantages in using a digital beam, although it may be performed without a digital beam. IBND is a multi-PVD/CVD process in which an organic gas is introduced to a workpiece after it has been exposed by a particle beam. Growth occurs from the nucleation (exposed) sites similar to ALD. IBND

generally employs an ion dosage that is about five orders of magnitude less than CAIBD, which enables IBND to be more than 100,000 times faster than CAIBD.

[0138] *In situ* deposition processes provide a variety of desired materials for the fabrication of silicon complementary metal-oxide semiconductors (CMOS), gallium arsenide, and other devices. However, deposition throughput and film quality are highly desired for such processes. Prior to IBND, reasonable throughput deposition for wafer fabrication was not possible using *in situ* beam processing. As an example, the rate of film deposition for CAIBD using a large ion dosage (e.g., 4×10^{16} ions/cm²) would be limited by the beam current to about 100 A/cm², and it would take over 20 years to deposit one square centimeter for a layer 500 Å thick. IBND, however, is able to produce desired film thicknesses while also satisfying throughput and quality concerns. For example, a process resulting in 30% coverage of the usable surface of a 300 mm diameter workpiece (about 200 cm²) by 2.5 Å of deposited material would take about five seconds to expose using an exposure chamber 102 having a beam current density of 10 A/cm², which can expose nucleation sites on the order of 10 cm²/s. The workpiece can then be transported to a nucleation chamber for deposition while another workpiece is exposed in the exposure chamber 102.

[0139] Figures 10A-10C schematically illustrate an example digital beam assisted deposition process. Starting with an unprocessed workpiece in Figure 10A, portions of the workpiece are exposed with groups of charged particles of a digital beam, represented by arrows 1002 in Figure 10B. The workpiece is then transferred to a deposition chamber, where it is exposed to reactant (e.g., a reactant fluid, preferably a reactant gas). The reactant reacts with the exposed areas to nucleate or atomically deposit a material, resulting in the workpiece of Figure 10C with an area 1104 of deposited material.

[0140] Integrated microelectronic manufacturing of silicon, gallium arsenide, and other electronics utilize ion implantation to alter device mobility profiles at transistor junction edges. Traditional implantation techniques generally include resist deposition, patterning, development, and baking, followed by ion implantation, resist removal (e.g., by ashing and/or stripping), and cleaning. Device fabrication uses a series of these implantation techniques, thereby requiring a large number of patterning steps. Patterning may be reduced by using serial implantation, but devices incorporating gradient implantation, lightly doped

drains (LDD), and co-implantation, which can achieve higher performance, typically trade process simplification for increased device performance. For example, high resolution implantation placement accuracy may result in increased device reliability and/or process robustness. Throughput limitations associated with the traditional implant techniques are exacerbated by devices that require a large number of implantations. Using a conventional CMOS process as an example, implantation alone (i.e., resist deposition, patterning, development, and baking followed by ion implantation, resist removal, and cleaning) may require about 70 process steps. As a result, the cost of the next generation, high leverage electronics can be substantial.

[0141] The development of such implantation schemes can be particularly costly. For example, the fabrication of reticle masks used in the resist patterning steps may take on the order of months and tens of thousands of dollars. Process development (e.g., the resist exposure conditions appropriate for the reticle, resist type, resist thickness, etc.) may take additional months. Once developed, pilot fabrication can take weeks or months. If testing reveals defects in the reticle design or the process steps, the process may need to start over, and iterates until a functional device can be reliably created. Such lengthy development is impractical or even impossible for certain devices (e.g., specialty military devices where a limited number of devices will be produced).

[0142] The use of resistless, direct write implantation can provide the manufacturing flexibility and quick development time to incorporate advanced techniques (e.g., single-level gradient implantation, LDD, and co-implantation) in research, pilot production, and full production environments. Such a system can achieve vertical implantation profiles ranging from about 5 kilo electron volts (keV) to about 500 keV within, for example, about 20 nm. These systems can have the flexibility to select the species of the ion beam and to place the beam within 9 nm of itself in a gradient energy or dose profile, which can be used to achieve advanced implantation processes such as gradient implantation, LDD, and co-implantation.

[0143] Figures 11A through 11D schematically depict a cross-section of a workpiece processed with direct write implantation. Starting with an unprocessed workpiece in Figure 11A, the workpiece is implanted with a first set of digital beam exposure profile,

represented by arrows 1100 in Figure 11B. The result is a workpiece of Figure 11C with an area 1102 of doped material. An implantation with a second digital beam exposure profile, represented by arrows 1104 in Figure 11C, is then performed. The result is a workpiece of Figure 11D with doped area 1102 and doped areas 1106. The workpiece may be annealed after each implantation or after the series of implantations to activate the dopants. In certain embodiments, the workpiece illustrated in Figure 11D can be performed with a single implantation, for example using the techniques illustrated in Figures 11E through 11I.

[0144] In Figure 11E, the charged particle density of the groups of charged particles are altered as they are scanned across the workpiece, illustrated by arrow 1108. Area 1110 of the workpiece is lightly doped (e.g., n^-) while area 1120 is heavily doped (e.g., n^{++}). Figure 11F is a plot of the log of dosage versus position of a workpiece similar to that of Figure 11E. The dosage profile can become linear by, for example, overlapping the beams of Figure 11E. In Figure 11G, the energy of the beam is altered as it scans across the workpiece, illustrated by arrow 1122. Area 1124 of the workpiece is shallowly doped (e.g., like a lightly doped drain) while area 1134 is deeply doped (e.g., like an n-well). Figure 11H is a plot of the implant depth versus position of a workpiece similar to that of Figure 11G. The dosage profile can become linear by, for example, overlapping the beams of Figure 11G. In some embodiments, the energy varies between about 5 and 500 keV, or more preferably between about 5 and 200 keV. In Figure 11I, the charged particle density of the groups and the energy of the groups are altered as the digital beam scans across the workpiece, illustrated by arrow 1136. Area 1138 of the workpiece is both lightly and shallowly doped while area 1148 is both heavily and deeply doped. Although not illustrated, it will be understood that other beam parameters, for example species, may also be altered. In certain embodiments, the beam is altered across a transistor, across a die, or across a workpiece. In certain embodiments, the beam is altered within about a 20 nm area on the workpiece. Alteration of the beam may also enhance etching, deposition, and other processes.

[0145] The standard approach for achieving acceptable levels of reliability in devices with gate lengths under 1.5 μm is to incorporate the use of a lightly doped drain (LDD) process. This two-step implantation process creates source and drain regions that lower the electric field near the channel edge, which lowers the impact ionization rate and

results in fewer hot carriers available for migration into the gate oxide, thereby enhancing the long term reliability of the device. Beam implantation enables proper horizontal grading of the source/drain implant, which allows completion of the entire LDD process in a single step. As such, beam implantation can eliminate two photoresist steps and the need for a sidewall spacer and its associated etching process, which can particularly affect yield due to damage to the silicon substrate.

[0146] The LDD process can degrade the peak transconductance of a 1 μm gate length device by roughly 10% and a 0.5 μm gate length device by as much as 20%. However, elimination of ion implantation on one side can result in considerable improvements in device performance. With conventional processing, this would require additional patterning steps to mask the source side, and hence is almost never performed. Beam implantation, however, allows the LDD to be placed only on the drain side of the transistor channel, where the electric field is high, and ion implantation can be omitted from the source side. Figures 12A through 12C depict example schematic cross-sections of implant structures within workpieces that can be achieved with a single digital beam process step.

[0147] Beam implantation can also be used to improve device scaling. A limited factor in controlling device scaling is the source/drain junction depth. The shallower the junction, the fewer the short channel effects and the greater the degree of scalability. However, a shallow junction results in increased parasitic source/drain resistance. The impact of this source drain/resistance is appreciable for deep sub-micron devices. The lateral grading potential of beam exposure can be particularly useful in this instance, for example by making a drain that is very shallow near the transistor channel yet deep under the transistor contact. The shallow junction near the channel edge results in reduced short channel effects, while the deep junction under the contact promotes low series resistance. Another option is placing a deep junction on the source side and a graded junction on the drain side. This can keep the series resistance at a minimum on the source side where it is most important while reducing the negative effect of drain induced barrier lowering on the drain side.

[0148] Lateral channel doping variations produced by digital beam implantation permit the construction of high performance, high yield planar gate FETs. LDD regions increase the output resistance and breakdown voltage of the transistor, which increases power

capability. As illustrated in Figure 13A, increasing the doping of the source and beneath the gate (area 1302 of Figure 13A) can reduce the source-gate resistance to improve the FET transconductance and gain by increasing the channel current. These desired lateral doping variations, illustrated by the chart of Figure 13B, can be produced by varying the implant dose in segments along the length of the channel. The number of different segments that can be used is only limited by the digital beam size.

[0149] Although GaAs FETs are a key element of many microwave (or millimeter-wave) monolithic integrated circuits (MIMIC), other elements such as Schottky diodes are frequently fabricated on the same workpiece for high performance devices. However, a FET gate cannot be used as an ideal diode because the cutoff frequency is much lower than a high quality Schottky diode. Fabrication of FETs and Schottky diodes on the same workpiece is difficult to accomplish with either epitaxial growth or blanket implantation processing. Digital beam processing is well suited for selective ion implantation processing of FETs and diodes on the same workpiece because the ability to perform discrete processing at different location on the workpiece, as illustrated in Figure 15. The resulting devices are substantially planar, which improves yield. As is true with all processes described herein, other processing steps may be combined with traditional processes.

[0150] GaAs MIMICs are traditionally produced using blanket implantation and deposition steps, and batch etching and alloying steps. Photoresist is used to selectively mask and define the device and circuit patterns at each level. Altogether, traditional methods employ over 25 different process steps including 12 mask levels. The front-end (topside) process alone typically takes over 240 hours to complete for a 6-workpiece batch. The process is very inefficient because of the large amount of overhead time and touch labor required. GaAs MIMIC processing can be significantly improved and simplified to increase yield and lower cost by designing a digital beam process of selective pixel based implantation, deposition, and etching. Digital beam processing offers tremendous benefits in simplification and improvement of the GaAs MIMIC process, thereby leading to faster cycle times, higher circuit yields, and lower chip costs. *In situ* processing can eliminate more than a dozen process steps that typically take nearly 100 hours to perform, and enables major

process modifications for improving device performance, yield, lowering cost, and expanding capability within an acceptable timeframe. For example, a digital beam process may comprise only 9 steps and 19 operations, reducing cycle time to 40 minutes per wafer. As illustrated in Figure 16A through 16K, an example GaAs MIMIC digital beam process comprises selective channel and contact implants followed by annealing. Ohmic contacts are delineated and contact metal is deposited by digital beam deposition followed by digital beam isolation implant. The contacts are alloyed by annealing. Thin film resistors, FET gates, metal interconnects, insulators, and passivation layers are digital beam deposited.

[0151] Multifunction MIMICs (MFICs) integrate multiple functions in a single device. Traditionally, GaAs MFICs have been fabricated with increased levels of integration of receiver functions, combining analog and digital functions, and combining transmitter and receiver functions. MFICs lower system cost by reducing parts count, size, weight, and assembly/tune costs. Wafer scale integration (WSI), which would integrate many dissimilar functions to form a complete system on a wafer, is well suited for many generation of future microelectronics. MFICs are generally required for advanced phased array antenna systems, which integrate complex radio frequency functions with optical control and digital signal processing. An example is the System Level Integrated Circuit (SLIC). Most of the components developed for phased array applications are designed individually using hybrid assembly techniques. Sufficient support functions are not integrated, hence, cannot be inserted into the system directly. Monolithic integration of the circuit functions reduces part count, size, weight, and assembly costs.

[0152] High electron mobility transistors (HEMT) are heterojunction FETs with greatly improved performance over conventional GaAs FETs. HEMTs are generally used in high speed digital circuits and low noise amplifiers operating at millimeter-wave frequencies. High speed, ultra-low power digital circuits typically have complementary n-channel and p-channel FETs fabricated on the same workpiece, which is difficult, even with selective epitaxial material growth techniques. Digital beam processing implantation is well suited to fabricate complementary heterojunction insulating gate (HIG) FETs on the same wafer. Cross-sections of the basic n and p channel HIGFET devices are shown in Figures 14A and 14B, respectively. The devices are substantially planar and embedded in a semi-insulating

substrate. A digital beam comprising silicon can be used for the n-channel device implant, and digital beam comprising beryllium can be used for the p-channel device implant. The metal-silicide gate (e.g., Schottky gate) and ohmic contacts (e.g., comprising AuGe, AuZn) can be deposited by digital beam deposition. Such a sequence allows a two step *in situ* device fabrication process. As a result, the unique features of the device would be a high resolution dual proximity printing with a minimum step process.

[0153] Heterojunction bipolar transistors (HBTs) are typically used in devices with high linearity, precision analog, digital/digital converter, and microwave power applications. However, current gain and maximum frequency of oscillation are limited by parasitic base resistance and collector capacitance, respectively. The performance and yield of GaAs HBT devices can be improved with selective digital beam implantation. Figure 17 represents an example cross-section of a workpiece under such an application. First, beryllium implants into the substrate before contact metallization reduces contact resistance. The base layer can have a lower doping concentration for the same base contact resistance, which increases the current gain by promoting electron transportation through the p-type base. Second, oxygen or boron implantation between the emitter and base electrodes electrically isolates and confines the electron current to flow vertically through the device rather than recombining laterally. This reduces stray capacitance and improves the operating frequency. Such fabrication processes are difficult to perform with standard photoresist processing techniques because of the small dimensions and because photoresist processing increasing surface recombination which decreases gain.

[0154] The lateral doping capability of a beam implant can also improve device scalability through use of channel stop implants. Such channel stop implants usually reduce the effective device width of narrow transistors, reducing the junction capacitance and increasing the performance of the technology. With conventional implants, difficulty in tailoring the doping concentration along the edge of the field oxide can result in more implant than needed going into the active area. With a beam exposure, the implant can be spatially controlled to keep a sufficient, but not excessive, surface concentration along the field oxide edge.

[0155] Varying the channel stop implant can include grading a channel stop or guard ring implant along a bird's beak to prevent field inversion resulting from ionizing radiation. Guard ring approaches normally result in large area penalties because the implant dose required for hardness is sufficiently high to promote breakdown problems from the close proximity of n^+/p^+ regions. Leaving a space between the guard ring and the n^+ implant layers can solve this breakdown problem (e.g., as depicted in Figure 19A). Although effective, this approach can result in a large density penalty, especially as devices are scaled into the sub-micron regime. Using a digital beam exposure, a horizontal doping gradient can decrease the ion dosage near the junction edge, where the field oxide is thin and thus less sensitive to radiation, and can increase the ion dosage under the thicker part of the field oxide. Using such a strategy can achieve excellent radiation hardness, while not compromising the layout density due to the potential breakdown problem. Implantation of a non-conducting layer can be used to form a very dense isolation approach. An implantation of sufficient dosage (e.g., between about 1×10^{15} charged particles/cm² and 1×10^{17} charged particles/cm²) forms amorphous regions with essentially infinite resistivity (e.g., as depicted in Figure 19B). Devices can thus be isolated from each other by this high resistance region. The dimensions of this isolation region can be extremely small, for example much smaller than an oxide isolation guard ring, resulting in greatly improved circuit densities.

[0156] In some CMOS applications, the use of a bipolar transistor can be very desirable. This has led to the widespread interest in BiCMOS technology. Many of these applications do not require a high frequency bipolar device, and hence the greatly increased process complexity associated with BiCMOS is not warranted. A lateral bipolar device exists in every CMOS technology, but typically performance is too poor to have widespread use. Using beam exposure implantation can greatly improve the performance of this lateral bipolar transistor technology. Horizontal grading in the channel (base) region can result in electric field aided minority carrier transport, improving both transistor beta and transition frequency (F_t). An LDD process destroys the emitter efficiency of this bipolar device, so the ability to selectively place LDDs on the drain side of the channel allows the source regions to act as emitters and to not be processed as LDDs.

[0157] It will be appreciated that digital beam implantation can be used for other applications and devices, and the embodiments described herein are only examples. It will also be appreciated that combinations of digital beam processes including etch, implant, and deposition can be used to form a wide variety of semiconductor devices and the embodiments described herein are only examples. For example, Figure 18 depicts a process sequence for building a substantially completed semiconductor device. Some steps may be performed with traditional methods and combined with digital beam processing, or, preferably, each of the process steps is performed using digital beam processing.

[0158] Annealing is a process by which the atoms or molecules in a material layer are heated or energized in order to activate dopants, change film-to-film or film-to-wafer substrate interfaces, densify deposited films, change states of grown films, repair damage from ion implantation, move dopants, drive dopants from one film into another or from a film into the wafer substrate, to drive off excess solvents (e.g., from resist deposition, spin-on dielectrics, etc.), and the like. As such, annealing is particularly useful in conjunction with direct write processes. However, it will be appreciated that a workpiece need not be exposed in a beam exposure chamber prior to rapid thermal annealing.

[0159] Combinations of the above and other processes can be used to produce workpieces that are substantially finished (e.g., ready for passivation, ready for die cutting, etc.) from a bare substrate (e.g., a single-crystal wafer, a workpiece with a deposited field oxide) in a single processing tool.

[0160] The demand for military and commercial electronics will continually drive advances in a wide range of integrated circuits that use the same or similar forms of logic cells. Over the past several years, multiple exposure technologies have been used to meet the demands of the ever decreasing next node critical geometries. Generally, increasing the number of processing steps reduces manufacturing yield and throughput, resulting in expediential cost increases per new design rule. A promising manufacturing technology, which simultaneously addresses cost, resolution, and throughput and process yield improvement does not currently exist for the future development of new devices. A paradigm combining semiconductor processing and lithography to offer digital beam pattern processing can thus provide a solution to the future of the industry.

[0161] Incorporating resistless digital beam exposure aided deposition, etching, and implantation processing on a fully automated, high throughput cluster processing tool can provide a significant reduction in the manufacturing cost of high performance and/or high density integrated circuits. For example, the manufacture of a partially *in situ* 15 nm source/drain BiCMOS device can include the spontaneous nucleation of tungsten, silicon oxide, and platinum for the alignment or metallization, dielectric insulators, and silicide, respectively. A deep sub-micron polysilicon gradient implantation source/drain technology can be used to minimize the number of implantation levels while maximizing the performance of the devices. DBACE can be used for LOCOS and the formation of gate oxides. Polysilicon for the implantation, gate, and passivation levels can be deposited on the entire wafer in a CVD chamber on the apparatus. The field oxide can be the only *ex situ* process done outside of the system prior to all other processes.

[0162] Several different pixel/digital beam spot size combinations can be used for exposure at different workpiece levels in order to simultaneously maximize the resolution and throughput of the processing tool. Exposure strategies can also be used to compensate for uniform nucleation deposition as discussed above. To increase the sensitivity of the digital beam exposure aided deposition process, several levels can be exposed with reduced beam current density without reducing the throughput of the system. In order to perform a complete *in situ* process, the tool can include one or more dedicated oxidation (e.g., plasma enhanced CVD (PECVD)) and nucleation chambers.

Masks

[0163] As described above with respect to Figures 9A-9C, a workpiece may be exposed with groups of charged particles and then transferred to an etchant chamber. In the etchant chamber, a reactant gas removes the portions of the workpiece exposed to the charged particles. Other methods of processing a workpiece use conformal masks. Conformal mask processing techniques can improve the throughput of the focused ion beam system. Example processes for forming light field and/or dark field conformal masks are described below. These conformal masks can be incorporated into other fabrication processes. For example, a conformal mask could serve as a process mask for subsequent deposition, implanting, or etching of semiconductor materials.

[0164] Ion beam processing of semiconductor (or other) devices is an attractive alternative to exposure of photoresist by light. The advantage of defining patterns with ions instead of photons is particularly apparent as pattern feature sizes become smaller than the photon wavelengths. The resolution of photolithography processes based on optically imaging a reticle onto a workpiece such as a semiconductor wafer are restricted by several factors including the diffraction limit, which depends on the wavelength of light. Accordingly, photolithography systems that utilize light of shorter and shorter wavelengths are being developed to increase the resolution and reduce the critical dimension. Light sources in the x-ray and shorter wavelengths, however, have further thermal transfer complications relating to pattern overlay inaccuracies and are difficult to produce and project. Ion beams, in contrast, can be produced, accelerated, and used to create patterns with minimal thermal transfer and non-linear pattern overlay correction by a number of methods, for example by direct writing or by projection through physical masks. A major limitation, however, of ion beam lithography is the slow deflection speed causing a relatively long time required to write fine lines on workpieces using equipment that is also typically expensive. Processes such as ion beam etching and deposition may involve higher ion doses and consequently may further decrease throughput. Hence, it is desirable to produce patterns in a mask material using decreased ion beam doses. The patterns can be subsequently processed outside the ion beam chamber to transfer the pattern to a process mask, after which the workpiece may be etched, deposited upon, or ion implanted using other methods and apparatuses.

[0165] A conformal mask may be formed from a stack of layers. In a preferred embodiment, each layer has a high etch selectivity and is thinner than the layer below it. The topmost layer preferably has a thickness on the scale of angstroms, which decreases the exposure time required for ion beam sputtering. Reducing the thickness of the topmost layer operated on by the ion beam reduces the amount of ions necessary to pattern the top layer, for example, to write a pattern in the topmost layer. Hence, the dose and/or time of exposure of the ion beam is reduced. The ratio of atoms removed per exposing pixel area can also be adjusted by controlling the beam parameters (ion species, beam energy, and beam current). Selecting the specific materials for binding energy and chemical interaction with the ion

beam parameters for the purpose of obtaining a high sputter yield (atoms per ion removed) can improve throughput of the process. A high sputter yield reduces the ion dose and, hence, exposure time thus improving exposure throughput.

[0166] Once the topmost layer has been patterned by the ion beam and the exposed areas are removed, the substrate may be processed to remove material in a lower layer, thereby transferring patterns in the top layer down to the lower layer or layers. The substrate, for example, may be processed in a Reactive Ion Etch (RIE) or other etch chamber. RIE is preferable for its high selectivity and anisotropy, however other etch processes can be used. Wet etch may be suitable in some embodiments. Other dry etches, such as ICP, Plasma enhanced ECR, or Ion Mill may also be substituted for Reactive Ion Etch to achieve the same effect. In some embodiments comprising a photosensitive layer, exposure to light or UV and developer can be used to remove mask material from the photosensitive layer and transfer the patterns.

[0167] Alternating etches with appropriate ion species can be used to selectively etch through the layers, transferring the pattern down from the topmost layer to a bottom layer, e.g., an organic layer, which can act as a mask for subsequent processing. Selective etching refers to etching processes in which one material is etched rapidly while the other is etched very slowly or not etched at all. The cascading of layers of increasing thickness combined with pattern transfer processes with high selectivity can enable a thin top mask layer configured for ion beam writing to define a thicker process mask layer, where the relative thickness increase is the product of the selectivity of subsequent layer etches.

[0168] Example processes for producing both light field and dark field conformal masks are disclosed. In certain embodiments, the pattern is defined in a very thin topmost layer, advantageously providing high resolution while high energy ions do not impact the semiconductor surface, thereby avoiding unintentional damage to the underlying devices.

[0169] A bare or in-process semiconductor wafer (or other substrate or workpiece), which may have various patterned layers or devices on its surface, is coated with a process mask layer that resists subsequent traditional process steps in the device fabrication, for example, but not limited to, wet or dry etching, deposition of conductor, semiconductor, or insulator, and ion implantation. In certain embodiments, the process mask layer is organic.

Photoresist is a good example of a suitable organic, although its light sensitive properties are not required in all embodiments. Integration with organic process masks such as photoresists offers a variety of advantages. Organic masks are preferred in certain embodiments for their resistance to chemicals. The use of an organic process mask layer beneath the FIB mask layer may also ensure that ion damage does not penetrate to and thereby damage semiconductor devices below the mask.

[0170] In certain embodiments, an etch mask layer is deposited. The etch mask layer material can be selected, for example, to be etched by a reactive ion etch that does not etch organic material. Suitable etch mask layer materials are materials such as metalloids or semiconductors such as silicon (Si) or metals such as titanium (Ti). Other materials, however, may be used. In various embodiments, the etch mask layer is thinner than the process mask layer. Such materials can be deposited, for example, by thermal or e-beam evaporation or sputtering. Many plasmas can also be used for depositions; these typically uniformly deposited films can advantageously be easily removed using solvents which dissolve the organic process mask utilized in some embodiments.

[0171] Next, a FIB mask layer comprising a material that can be efficiently removed by a FIB is deposited. In certain embodiments, the FIB mask layer material is selected to provide high etch selectivity to the etching of the etch mask layer. The FIB mask layer can also be selected to provide etch selectivity to the etching of the process mask layer. In various embodiments, the FIB mask layer is thinner than the etch mask layer and/or the process mask layer.

[0172] In the example embodiment illustrated in Figure 22A, an in-process patterned silicon substrate 2210 is first coated with a process mask layer 2220. The process mask can be, for example, between 1 and 1000 nm thick (e.g., comprising between about 100 and 300 nm of an organic material). In embodiments in which the process mask layer 2220 comprises an organic material, a standard spin and bake method may be employed. An etch mask layer 2230 (e.g., comprising about 10 nm of Si or Ti) is deposited on the process mask layer 2220. Example deposition processes for the etch mask layer 2230 include sputtering and e-beam evaporation. A FIB mask layer 2240 (e.g., about 1-2 nm thick) is deposited on the etch mask layer 2230. In some embodiments, the FIB mask layer 2240 comprises an

oxide layer (e.g., silicon dioxide (SiO_2) or aluminum oxide (Al_2O_3)), for example, deposited by sputtering or evaporation.

[0173] The wafer is then transferred into a FIB chamber. Upon registration of alignment marks, a FIB 2250 writes a desired pattern on the surface with the appropriate ion type, energy, and dose to remove certain portions of the FIB mask 2240, as shown in Figure 22B. Any suitable FIB write process and/or chamber may be used. As described above, in certain embodiments, a stream of charged particles emanates from a charged particle source and is collimated and directed along an axis. The physical properties of the beam of charged particles traveling along the axis with a distribution transverse to the axis can be modified to provide a high speed, digital (or “pulsed”) distributed writing beam. Various methods can be used to create a wave of temporally and spatially defined high-density charged particle anti-nodes and low density (or no density) nodes, traveling in a longitudinal path of accelerated particles (a “digitized beam”). As further described above, certain FIB exposure chambers are able to write only where written features are to be formed because the digital beam only scans selected areas, but the beam does not need to be turned off to be moved to another area. In certain preferred embodiments (e.g., using the FIB chamber described above), the FIB chamber can adjust ion type, energy, dose, position, etc. For example, writing with a digital beam can preferably augment transformed pattern data to compensate for deflection field distortion, wafer distorted pattern placement errors, stage position, etc. The FIB mask thickness is very thin in some embodiments, as it only has to withstand the transfer of the pattern to the etch mask. In these embodiments, the FIB beam spot is reduced, thus avoiding the backscattering bloom that typically occurs as the beam penetrates further into the mask material.

[0174] In alternative embodiments, the FIB system is coupled (e.g., fluidly coupled under vacuum) to an atomic layer deposition (ALD) system. ALD deposits monolayer coverage of oxides by a first exposure of the wafer surface to a precursor gas that adsorbs on the surface and then a second exposure to a reactive gas that combines with the adsorbed precursor to produce a monolayer of oxide. By repeated exposure to the two gas cycles, oxide layers can be grown with monolayer control and excellent conformal coverage. In such embodiments, the wafer with the process mask or process and etch mask is first

exposed to the precursor. As shown in Figure 22B, the precursor can be easily removed by subsequent exposure to FIB as it is an adsorbed molecule and not yet an oxide, advantageously improving ion sputter yield and reducing the requisite ion dose. In this manner, the FIB can pattern the precursor. In such embodiments, the wafer is finally exposed to the reactive gas to complete the cycle, providing monolayer coverage of oxide that has been patterned by the FIB.

[0175] Once the FIB mask layer 2240 is patterned, the pattern is transferred to a lower layer. The wafer, for example, may be etched using a dry etch such as a reactive ion etch (RIE) process. RIE (e.g., as shown in Figure 22C) can etch the exposed portions of a lower layer across the entire wafer. In certain embodiments, the pattern transfer process is configured to improve the etch selectivity to one layer relative to another layer (or other layers). For example, the selectivity of an RIE process to the etch mask material 2230 relative to the FIB mask material 2240 can be around 100x. That is, the etching rate of the etch mask layer 2230 is 100 times faster than that of the FIB mask layer 2240 using the RIE process in that embodiment. In certain embodiments, chlorine RIE can be used to etch the Si or Ti etch mask material. Chlorine may be selected because it does not typically react with the oxide in the FIB mask layer 2240 or organic material in the process mask layer 2220, while it is generally highly reactive with Ti and Si. The pattern in the FIB mask layer 2240 is thus transferred to the etch mask layer 2230 or, in certain embodiments, to the process mask layer 2220.

[0176] Such processes may advantageously retain the critical dimensions of certain features in a thicker lower layer, for example, an etch mask layer 2230 that is thicker than the FIB mask layer 2240. Moreover, because the FIB mask layer 2240 is patterned without a reticle, the pattern can adjust for nonconformities on the wafer.

[0177] In embodiments comprising an etch mask layer, the pattern may subsequently be transferred to the process mask layer 2220, for example, etched using a suitable RIE that preferably does not react with the etch mask layer 2230. The anisotropic nature of the RIE again allows the critical feature dimensions to be maintained while the pattern is transferred to the thicker material of the process mask layer 2220. In the embodiment illustrated in Figure 22D, an oxygen RIE having a beam 2270 of reactive ions

etches the process mask layer 2220, while it does not substantially react with the either Si or Ti of the etch mask layer 2230. In certain embodiments, the FIB mask layer 2240 is removed by one of the processes for transferring the pattern through the various layers; for example, the FIB mask layer may be sputtered away during oxygen RIE as a result of being thin. The FIB mask layer 2240 may also intentionally be removed by another separate process.

[0178] Other pattern transfer processes can be used. For example, in certain embodiments comprising a photosensitive process mask layer, the wafer as illustrated in Figure 22C is exposed to an appropriate wavelength and the exposed portions of the process mask layer 2220 are developed away (e.g., using a wet chemical develop). The etch mask layer 2230 shields the unexposed portions such that a traditional reticle is not needed. Such embodiments allow integration with existing fabrication equipment. However, wet chemical developing may in some embodiments increase the critical dimensions of certain features.

[0179] Figure 22D shows the resultant conformal mask (layers 2220, 2230). The wafer is ready for subsequent processing using this conformal mask.

[0180] In various embodiments, it may be undesirable to leave the etch mask layer 2230 on the process mask layer 2220 during a process mask etch. In these embodiments, the process for transferring the pattern through the process mask layer can be stopped prematurely. For example, the oxygen RIE can be stopped before the process mask layer 2220 has been completely etched through, for example at about 70% completion, to allow for variations in the layer and etch across the wafer. A suitable chemical process for removing the etch mask layer, for example a carbon tetrafluoride (CF₄) or chlorine plasma etch, can optionally be used to strip the patterned etch mask layer 2230. The wafer can then be returned to the oxygen RIE or other suitable etch, and the entire process mask layer 2220 is thinned (or “etched back”) while the pattern is transferred to the wafer surface (e.g., in the form of trenches).

[0181] Such processes may result in what can be referred to as a “dark field mask,” where the areas that are exposed to the FIB become openings in the process mask layer 2220. In certain embodiments, reducing or minimizing the area exposed in the FIB chamber can increase the throughput of the FIB chamber. Depending on the pattern and subsequent process step, dark field or light field patterns are preferred. The use of both

process types can ensure that exposure desirably does not exceed 50% of the wafer surface in certain embodiments.

[0182] The preparation of an example light field conformal mask is illustrated in Figures 23A-23F. A first process mask layer 2320 (e.g., similar to the process mask layer 2220 described above), such as an organic material, is deposited over a wafer substrate 2310. A plating base layer 2324 can be deposited over the first process mask layer 2320. In certain embodiments, the plating base layer 2324 comprises a metal. Many different metals can be selected for the plating base layer 2324 depending on what would be appropriate for subsequent process steps. In certain embodiments, for example, the plating base layer 2324 comprises a conductive metal such as titanium. A second process mask layer 2326, e.g., a second organic mask layer, is deposited. The embodiment shown in Figures 23B-23D is similar to the pattern transfer sequence described above for Figures 22B-22D, but the pattern is transferred down to the plating base layer 2324 rather than down to the substrate 2310 (e.g., including transferring the pattern to the second organic layer 2326 using either RIE beams 2360, 2370 or non-reticle exposure). In certain embodiments, the FIB mask layer 2340 is removed by one of the processes for transferring the pattern through the various layers; for example, the FIB mask layer may be sputtered away during RIE as a result of being thin. The FIB mask layer 2240 may also intentionally be removed by another separate process.

[0183] In an embodiment illustrated in Figure 23E, the wafer is transferred to an apparatus that fills the opening in the second process mask layer to create a fill layer. In certain embodiments, this can be accomplished using an electroplating apparatus. Selective electroplating using the plating base 2324 for cathodic electrical contact fills the opening in the second organic layer 2326 with an electroplated material 2380, thereby producing a metal mask 2390 while maintaining the critical dimensions of the pattern features. Other embodiments may comprise an electroless plate to create the fill layer. Other kinds of chemical reactions that could convert the chemistry of the exposed surface, changing the etch selectivity, may also be suitable alternative embodiments to a fill layer. Many different materials can be selected for the fill layer 2390, for example metals, depending on desired properties and what would be appropriate for subsequent process steps. In some

embodiments, plating techniques such as pulsed plating can be used to ensure uniform electroplating across the wafer. Other processes, however, can be used in different embodiments.

[0184] The wafer may then be transferred to an etch or other suitable chamber, for example, an RIE chamber, where the pattern in the fill layer 2390 is transferred through the process mask layer 2320, for example as shown in the embodiment of Figure 23F. Beams 2394 of alternating RIE ions or other suitable process can be used to remove mask materials such as 2330, 2326, 2324, 2320 while the materials 2324, 2320 under the fill layer 2390 are not removed. For example, chlorine RIE can be used to etch the etch mask layer 2330, oxygen RIE can be used to etch the second process mask layer 2326, chlorine RIE can be used to etch the plating base layer 2324, and oxygen RIE can be used to etch the first process mask layer 2320. Such a sequence can produce a light field pattern where the first process mask layer 2320 is protecting the areas where the FIB mask layer 2340 was exposed to the FIB beam 2350. In some embodiments, the fill layer 2390 comprises electroplated lines which are the finished final product to be incorporated into the wafer.

[0185] Figure 23F shows the resultant conformal mask (layers 2390, 2324, 2320). The wafer is ready for subsequent processing using this conformal mask. In certain embodiments, a light field conformal mask can be created using focused ion beam deposition. As described above, FIB can be used to deposit a thin patterned top layer, preferably on 50% or less of a wafer surface. The wafer can be subsequently processed using the pattern transfer sequence described above for Figures 22C-22D.

[0186] In certain embodiments, the above processes for producing dark field and light field conformal mask patterns on workpieces advantageously allows integration of FIB patterning with a wide range of semiconductor or other fabrication processes that otherwise are integrated with light-patterned photoresist. These and other embodiments enable FIB direct pattern (resistless) processing described above to conform to many semiconductor processing and other fabrication methods by integrating the use of a process mask, e.g., resist. These processes may also enable the use of a very thin FIB mask layer that needs reduced or minimal FIB exposure while producing a relatively thick process mask layer having critical dimensions of the features patterned in the FIB mask layer. Using the FIB to remove the thin

surface pattern instead of exposing resist to light radiated through a reticle provides improved critical dimension and fidelity that is desirable for ever-decreasing semiconductor features sizes.

[0187] A wide variety of variations are possible. Components may be added, removed, or reordered. Different components may be substituted out. The arrangement and configuration may be different. Similarly, processing steps may be added or removed, or reordered.

[0188] Applications for this technology are virtually unlimited and span far beyond the development of tomorrow's microelectronics components. Described above are a small number of high leverage electronics applications to demonstrate the potential of resistless processing, for example in the military and commercial electronics industries. A wide variety of other applications are possible. It will be appreciated that the majority of the *in situ* process steps can include a reduction in the system beam current density to 40 A/cm². This is equivalent to present day technology and greatly reduces the risk for each of these tasks.

[0189] Although this invention has been disclosed in the context of certain preferred embodiments and examples, it will be understood by those skilled in the art that the present invention extends beyond the specifically disclosed embodiments to other alternative embodiments and/or uses of the invention and obvious modifications and equivalents thereof. In addition, while several variations of the invention have been shown and described in detail, other modifications, which are within the scope of this invention, will be readily apparent to those of skill in the art based upon this disclosure. It is also contemplated that various combinations or sub-combinations of the specific features and aspects of the embodiments may be made and still fall within the scope of the invention. It should be understood that various features and aspects of the disclosed embodiments can be combined with, or substituted for, one another in order to form varying modes of the disclosed invention. Thus, it is intended that the scope of the present invention herein disclosed should not be limited by the particular disclosed embodiments described above or below.

What is claimed is:

1. A method for processing comprising:
 - providing a workpiece comprising a layer that is configured to be patterned by a particle beam and a first transfer layer thereunder, the particle beam patternable layer being thinner than the first transfer layer; and
 - exposing regions of the particle beam patternable layer using a collimated beam of spatially and temporally resolved charged particles thereby changing said regions;
 - wherein the first transfer layer is configured to be selectively processed relative to the particle beam patternable layer using a first removal process that removes regions of the first transfer layer having a shape substantially determined by the shape of the exposed regions of the particle beam patternable layer.
2. The method of Claim 1, further comprising a second transfer layer configured to be selectively processed relative to the first transfer layer using a second removal process that removes regions of the second transfer layer having a shape substantially determined by the shape of the exposed regions of the particle beam patternable layer.
3. The method of Claim 2, wherein said first transfer layer is between said particle beam patternable layer and said second transfer layer.
4. The method of Claim 2, wherein the first transfer layer is configured to be selectively processed relative to the second transfer layer using said first removal process.
5. The method of Claim 2, wherein the second transfer layer is about 1 to 1000 nm thick.
6. The method of Claim 5, wherein the second transfer layer is about 5 to 500 nm thick.
7. The method of Claim 6, wherein the second transfer layer is about 10 to 200 nm thick.

8. The method of Claim 2, wherein the second transfer layer comprises organic material.
9. The method of Claim 2, wherein the first transfer layer is thinner than the second transfer layer.
10. The method of Claim 2, wherein the first transfer layer is about 1 to 1000 nm thick.
11. The method of Claim 10, wherein the first transfer layer is about 5 to 500 nm thick.
12. The method of Claim 11, wherein the first transfer layer is about 10 to 200 nm thick.
13. The method of Claim 12, wherein the first transfer layer is about 1 to 20 nm thick.
14. The method of Claim 2, wherein the first transfer layer comprises a metal.
15. The method of Claim 14, wherein the first transfer layer comprises titanium.
16. The method of Claim 2, wherein the first transfer layer comprises a semiconductor or metalloid.
17. The method of Claim 16, wherein the first transfer layer comprises silicon.
18. The method of Claim 1, wherein the particle beam patternable layer is about 0.1 angstrom to 200 nm thick.
19. The method of Claim 18, wherein the particle beam patternable layer is about 5 angstroms to 100 nm thick.
20. The method of Claim 19, wherein the particle beam patternable layer is about 20 angstroms to 10 nm thick.
21. The method of Claim 18, wherein the particle beam patternable layer is about 1 to 2 nm thick.
22. The method of Claim 1, wherein the particle beam patternable layer comprises an oxide.

23. The method of Claim 22, wherein the particle beam patternable layer comprises aluminum oxide.

24. The method of Claim 1, wherein said particle beam patternable layer is formed by adsorbing atoms or molecules, and the particle beam patternable layer forms a complex when subjected to a reactive fluid.

25. The method of Claim 24, further comprising removing the exposed regions of the particle beam patternable layer.

26. The method of Claim 25, further comprising subjecting the adsorbed layer to the reactive fluid to form the complex in the regions of the particle beam patternable layer not subjected to the beam of charged particles.

27. The method of Claim 25, wherein the complex comprises an oxide monolayer.

28. The method of Claim 1, wherein the first removal process comprises an etch process.

29. The method of Claim 28, wherein the first removal process comprises a wet etch.

30. The method of Claim 28, wherein the first removal process comprises a dry etch.

31. The method of Claim 30, wherein the dry etch comprises reactive ion etch.

32. The method of Claim 2, wherein the second removal process comprises an etch process.

33. The method of Claim 32, wherein the second removal process comprises a dry etch.

34. The method of Claim 33, wherein the dry etch comprises reactive ion etch.

35. The method of Claim 1, wherein subjecting the regions of the particle beam patternable layer to the collimated beam of spatially and temporally resolved charged particles is adapted to substantially remove the regions of said particle beam patternable layer down to said first transfer layer.

36. The method of Claim 1, wherein the first transfer layer comprises organic material.

37. The method of Claim 36, wherein the first transfer layer is about 1 to 1000 nm thick.

38. The method of Claim 37, wherein the first transfer layer is about 5 to 500 nm thick.

39. The method of Claim 38, wherein the first transfer layer is about 10 to 200 nm thick,

40. A method for forming structures comprising:

providing a workpiece comprising a layer that is configured to be patterned by a particle beam and a first transfer layer thereunder;

exposing regions of the particle beam patternable layer to a collimated beam of spatially and temporally resolved charged particles thereby changing said regions;

removing the exposed regions of the particle beam patternable layer to reveal regions of the first transfer layer having a shape substantially determined by the shape of the exposed regions of the particle beam patternable layer; and

performing a first removal process on the first transfer layer thereby removing regions of the first transfer layer having a shape substantially determined by the shape of the exposed regions of the particle beam patternable layer.

41. The method of Claim 40, wherein the patternable layer is selected to have a particle beam sputter yield greater than 5 atoms/ion.

42. The method of Claim 41, wherein the patternable layer is selected to have a particle beam sputter yield greater than 50 atoms/ion.

43. The method of Claim 42, wherein the patternable layer is selected to have a particle beam sputter yield greater than 100 atoms/ion.

44. The method of Claim 43, wherein the patternable layer is selected to have a particle beam sputter yield greater than 500 atoms/ion.

45. The method of Claim 44, wherein the patternable layer is selected to have a particle beam sputter yield greater than 1000 atoms/ion.

46. The method of Claim 45, wherein the patternable layer is selected to have a particle beam sputter yield greater than 5000 atoms/ion.

47. The method of Claim 40, wherein the removed regions of the first transfer layer have substantially the same shape as the exposed regions of the particle beam patternable layer.

48. The method of Claim 40, wherein the removed regions of the first transfer layer have substantially the same critical dimensions as the exposed regions of the particle beam patternable layer.

49. The method of Claim 40, wherein the workpiece further comprises a second transfer layer configured to be selectively processed relative to the first transfer layer using a second removal process.

50. The method of Claim 49, wherein the first transfer layer is configured to be selectively processed relative to the second transfer layer using the first removal process.

51. The method of Claim 49, further comprising performing the second removal process on the second transfer layer thereby removing regions of the second transfer layer having a shape substantially determined by the exposed regions of the particle beam patternable layer.

52. The method of Claim 51, wherein the second removal process removes regions of the second transfer layer having substantially the same shape as the exposed regions of the particle beam patternable layer down to a material below the second transfer layer.

53. The method of Claim 51, wherein the removed regions of the second transfer layer have substantially the same critical dimensions as the exposed regions of the particle beam patternable layer.

54. The method of Claim 40, wherein the first removal process comprises an etch process.

55. The method of Claim 54, wherein the first removal process comprises a dry etch.

56. The method of Claim 55, wherein the dry etch comprises a reactive ion etch.

57. The method of Claim 49, wherein the second removal process comprises an etch process.

58. The method of Claim 57, wherein the second removal process comprises a dry etch.

59. The method of Claim 58, wherein the dry etch comprises a reactive ion etch.

60. The method of Claim 49, wherein the second pattern layer is selected to have a reactive sensitivity to light or UV of less than 100 mJ/cm^2 .

61. The method of Claim 60, wherein the second pattern layer is selected to have a reactive sensitivity to light or UV of less than 50 mJ/cm^2 .

62. The method of Claim 61, wherein the second pattern layer is selected to have a reactive sensitivity to light or UV of less than 10 mJ/cm^2 .

63. The method of Claim 62, wherein the second pattern layer is selected to have a reactive sensitivity to light or UV of less than 5 mJ/cm^2 .

64. The method of Claim 63, wherein the second pattern layer is selected to have a reactive sensitivity to light or UV of less than 1 mJ/cm^2 .

65. The method of Claim 51, wherein the second removal process comprises exposing the second transfer layer to light and applying developer to the exposed second transfer layer.

66. The method of Claim 65, wherein the developer comprises a wet chemical developer.

67. The method of Claim 51, further comprising stopping the second removal process when the second transfer layer reaches a selected thickness.

68. The method of Claim 67, wherein the selected thickness is about 0 to 90% of the thickness prior to application of the second removal process.

69. The method of Claim 68, wherein the selected thickness is about 0 to 70% of the thickness prior to application of the second removal process.

70. The method of Claim 69, wherein the selected thickness is about 0 to 50% of the thickness prior to application of the second removal process.

71. The method of Claim 67, further comprising:

substantially removing the particle beam patternable layer;

using a third removal process to at least partially remove the first transfer layer, the third removal process selectively processing the first transfer layer relative to the second transfer layer; and

using a fourth removal process to remove regions of the second transfer layer having a shape substantially determined by the exposed regions of the particle beam patternable layer.

72. The method of Claim 71, wherein the third removal process removes the first transfer layer down to the second transfer layer.

73. The method of Claim 71, wherein the third removal process comprises a dry etch.

74. The method of Claim 71, wherein the fourth removal process reveals regions of the workpiece having a shape substantially determined by the shape of the exposed regions of the particle beam patternable layer and reacts with the revealed regions of the workpiece.

75. The method of Claim 49, further comprising depositing a material into the regions of the first transfer layer.

76. The method of Claim 75, wherein the deposited material comprises a metal.

77. The method of Claim 75, wherein the workpiece further comprises a plating base layer and electroplating is used to deposit said deposited material.

78. The method of Claim 75, further comprising:
substantially removing the particle beam patternable layer;
selectively processing the first transfer layer relative to said deposited material using a third removal process; and
selectively processing the second transfer layer relative to the deposited material using a fourth removal process.

79. A method for processing comprising:
providing a workpiece comprising a layer that is configured to be patterned by a particle beam and a first transfer layer under the patternable layer; and

exposing regions of the particle beam patternable layer to a beam of charged particles thereby changing said regions;

wherein the first transfer layer is configured to be selectively processed relative to the particle beam patternable layer using a first removal process that removes regions of the first transfer layer having a shape substantially determined by the shape of the exposed regions of the particle beam patternable layer, the selectivity of the first removal process to the first transfer layer relative to the patternable layer being at least 2x.

80. The method of Claim 79, further comprising a second transfer layer configured to be selectively processed relative to the first transfer layer using a second removal process that removes regions of the second transfer layer having a shape substantially determined by the shape of the exposed regions of the particle beam patternable layer.

81. The method of Claim 80, the selectivity of the second removal process to the second transfer layer relative to the first transfer layer being at least 2x.

82. The method of Claim 81, the selectivity of the second removal process to the second transfer layer relative to the first transfer layer being at least 10x.

83. The method of Claim 82, the selectivity of the second removal process to the second transfer layer relative to the first transfer layer being at least 50x.

84. The method of Claim 83, the selectivity of the second removal process to the second transfer layer relative to the first transfer layer being at least 100x.

85. The method of Claim 84, the selectivity of the second removal process to the second transfer layer relative to the first transfer layer being at least 500x.

86. The method of Claim 79, the selectivity of the first removal process to the first layer relative to the patternable layer being at least 10x.

87. The method of Claim 86, the selectivity of the first removal process to the first layer relative to the patternable layer being at least 50x.

88. The method of Claim 87, the selectivity of the second removal process to the first layer relative to the patternable layer being at least 100x.

89. The method of Claim 88, the selectivity of the second removal process to the first layer relative to the patternable layer being at least 500x.

90. The method of Claim 80, wherein the second transfer layer is about 1 to 1000 nm thick.

91. The method of Claim 90, wherein the second transfer layer is about 5 to 500 nm thick.

92. The method of Claim 91, wherein the second transfer layer is about 10 to 200 nm thick.

93. The method of Claim 80, wherein the second transfer layer comprises organic material.

94. The method of Claim 80, wherein the first transfer layer is thinner than the second transfer layer.

95. The method of Claim 80, wherein the first transfer layer is about 1 to 1000 nm thick.

96. The method of Claim 95, wherein the first transfer layer is about 5 to 500 nm thick.

97. The method of Claim 96, wherein the first transfer layer is about 10 to 200 nm thick.

98. The method of Claim 95, wherein the first transfer layer is about 1 to 20 nm thick.

99. The method of Claim 79, wherein the first transfer layer comprises titanium.

100. The method of Claim 79, wherein the first transfer layer comprises silicon.

101. The method of Claim 79, wherein the particle beam patternable layer is about 0.1 angstroms to 200 nm thick.

102. The method of Claim 101, wherein the particle beam patternable layer is about 5 angstroms to 100 nm thick.

103. The method of Claim 102, wherein the particle beam patternable layer is about 20 angstroms to 10 nm thick.

104. The method of Claim 101, wherein the particle beam patternable layer is about 1 to 2 nm thick.

105. The method of Claim 79, wherein the particle beam patternable layer comprises an oxide.

106. The method of Claim 79, wherein said particle beam patternable layer is formed by adsorbing atoms or molecules, and the particle beam patternable layer forms a complex when subjected to a reactive fluid.

107. The method of Claim 106, further comprising removing said exposed regions of the particle beam patternable layer.

108. The method of Claim 107, further comprising subjecting the adsorbed layer to the reactive fluid to form the complex in the regions of the particle beam patternable layer not subjected to the beam of charged particles.

109. The method of Claim 107, wherein the complex comprises an oxide monolayer.

110. The method of Claim 79, wherein the first removal process comprises an etch process.

111. The method of Claim 110, wherein the first removal process comprises a dry etch.

112. The method of Claim 111, wherein the first removal process comprises reactive ion etch.

113. The method of Claim 80, wherein the second removal process comprises an etch process.

114. The method of Claim 113, wherein the second removal process comprises a dry etch.

115. The method of Claim 114, wherein the second removal process comprises reactive ion etch.

116. The method of Claim 79, wherein subjecting the regions of the particle beam patternable layer to the beam of charged particles removes the regions of said particle beam patternable layer down to said first transfer layer.

117. A method for forming structures comprising:

providing a workpiece comprising a layer that is configured to be patterned by a particle beam and a first transfer layer under the particle beam patternable layer,

the first transfer layer being configured to be selectively processed relative to the particle beam patternable layer using a first removal process that removes regions of the first transfer layer having a shape substantially determined by the shape of the exposed regions of the particle beam patternable layer, the selectivity of the first removal process to the first transfer layer relative to the particle beam patternable layer being at least $2x$;
and

exposing regions of the particle beam patternable layer to a beam of charged particles thereby changing said regions;

removing the exposed regions of the particle beam patternable layer to reveal regions of the first transfer layer having a shape substantially determined by the shape of the exposed regions of the particle beam patternable layer; and

performing the first removal process on the first transfer layer.

118. The method of Claim 117, selectivity of the first removal process to the first transfer layer relative to the patternable layer being at least 10x.

119. The method of Claim 118, selectivity of the first removal process to the first transfer layer relative to the patternable layer being at least 50x.

120. The method of Claim 119, selectivity of the first removal process to the first transfer layer relative to the patternable layer being at least 100x.

121. The method of Claim 120, selectivity of the first removal process to the first transfer layer relative to the patternable layer being at least 500x.

122. The method of Claim 117 further comprising a second transfer layer under the first transfer layer, the second transfer layer being configured to be selectively processed relative to the first transfer layer using a second removal process that removes regions of the second transfer layer having a shape substantially determined by the shape of the exposed regions of the particle beam patternable layer.

123. The method of Claim 122 further comprising performing the second removal process on the second transfer layer.

124. The method of Claim 122, the selectivity of the second removal process to the second transfer layer relative to the first transfer layer being at least 2x.

125. The method of Claim 124, the selectivity of the second removal process to the second transfer layer relative to the first transfer layer being at least 10x.

126. The method of Claim 125, the selectivity of the second removal process to the second transfer layer relative to the first transfer layer being at least 50x.

127. The method of Claim 126, the selectivity of the second removal process to the second transfer layer relative to the first transfer layer being at least 100x.

128. The method of Claim 127, the selectivity of the second removal process to the second transfer layer relative to the first transfer layer being at least 500x.

129. The method of Claim 117, wherein the particle beam patternable layer is selected to have a particle beam sputter yield greater than 5 atoms/ion.

130. The method of Claim 129, wherein the particle beam patternable layer is selected to have a particle beam sputter yield greater than 5 atoms/ion.

131. The method of Claim 130, wherein the particle beam patternable layer is selected to have a particle beam sputter yield greater than 50 atoms/ion.

132. The method of Claim 131, wherein the particle beam patternable layer is selected to have a particle beam sputter yield greater than 100 atoms/ion.

133. The method of Claim 132, wherein the particle beam patternable layer is selected to have a particle beam sputter yield greater than 500 atoms/ion.

134. The method of Claim 133, wherein the particle beam patternable layer is selected to have a particle beam sputter yield greater than 1000 atoms/ion.

135. The method of Claim 134, wherein the particle beam patternable layer is selected to have a particle beam sputter yield greater than 5000 atoms/ion.

136. The method of Claim 117, wherein the removed regions of the first transfer layer have substantially the same shape as the exposed regions of the particle beam patternable layer.

137. The method of Claim 117, wherein the removed regions of the first transfer layer have substantially the same critical dimensions as the exposed regions of the particle beam patternable layer.

138. The method of Claim 123, wherein the second removal process removes regions of the second transfer layer having substantially the same shape as the exposed regions of the particle beam patternable layer down to a material below the second transfer layer.

139. The method of Claim 123, wherein the removed regions of the second transfer layer have substantially the same critical dimensions as the exposed regions of the particle beam patternable layer.

140. The method of Claim 117, wherein the first removal process comprises an etch process.

141. The method of Claim 117, wherein the first removal process comprises a dry etch.

142. The method of Claim 141, wherein the first removal process comprises a reactive ion etch.

143. The method of Claim 122, wherein the second removal process comprises an etch process.

144. The method of Claim 143, wherein the second removal process comprises a dry etch.

145. The method of Claim 145, wherein the second removal process comprises a reactive ion etch.

146. The method of Claim 122, wherein the second pattern layer is selected to have a reactive sensitivity to light or UV of less than 100 mJ/cm².

147. The method of Claim 146, wherein the second pattern layer is selected to have a reactive sensitivity to light or UV of less than 50 mJ/cm^2 .

148. The method of Claim 147, wherein the second pattern layer is selected to have a reactive sensitivity to light or UV of less than 10 mJ/cm^2 .

149. The method of Claim 148, wherein the second pattern layer is selected to have a reactive sensitivity to light or UV of less than 5 mJ/cm^2 .

150. The method of Claim 149, wherein the second pattern layer is selected to have a reactive sensitivity to light or UV of less than 1 mJ/cm^2 .

151. The method of Claim 122, wherein the second removal process comprises exposing the second transfer layer to light or UV and applying developer to the exposed second transfer layer.

152. The method of Claim 151, wherein the developer comprises a wet chemical developer.

153. The method of Claim 123, further comprising stopping the second removal process when the second transfer layer reaches a selected thickness.

154. The method of Claim 153, wherein the selected thickness is about 0 to 90% of the thickness prior to application of the second removal process.

155. The method of Claim 154, wherein the selected thickness is about 0 to 70% of the thickness prior to application of the second removal process.

156. The method of Claim 155, wherein the selected thickness is about 0 to 50% of the thickness prior to application of the second removal process.

157. The method of Claim 123, further comprising:
substantially removing the particle beam patternable layer;
using a third removal process to at least partially remove the first transfer layer, the third removal process selectively processing the first transfer layer relative to the second transfer layer; and

using a fourth removal process to remove regions of the second transfer layer having a shape substantially determined by the shape of the exposed regions of the particle beam patternable layer.

158. The method of Claim 157, wherein the third removal process substantially removes the first transfer layer down to the second transfer layer.

159. The method of Claim 157, wherein the third removal process comprises a dry etch.

160. The method of Claim 157, wherein the fourth removal process reveals regions of the workpiece having a shape substantially determined by the shape of the exposed regions of the particle beam patternable layer and reacts with the revealed regions of the workpiece.

161. The method of Claim 123, further comprising depositing a material into the regions of the second transfer layer.

162. The method of Claim 161, wherein the deposited material comprises a metal.

163. The method of Claim 161, wherein the workpiece further comprises a plating base layer and electroplating is used to deposit said material.

164. The method of Claim 161, further comprising:
substantially removing the particle beam patternable layer;
selectively processing the first transfer layer relative to said deposited material using a third removal process; and
selectively processing the second transfer layer relative to the deposited material using a fourth removal process.

165. An in-process workpiece comprising:
a substrate;
a first transfer layer;
a second transfer layer between the first transfer layer and the substrate, said second transfer layer comprising organic material; and

a patterned layer of oxide, the first transfer layer disposed between the oxide layer and the second transfer layer,

wherein the first transfer material is configured to be selectively removed relative to the oxide layer and relative to the second transfer layer, and

wherein the second transfer layer is configured to be selectively removed relative to the first transfer layer.

166. The workpiece of Claim 165, wherein the organic material comprises photoresist.

167. The workpiece of Claim 165, wherein the oxide layer has a thickness between about 0.1 angstroms and 200 nm.

168. The workpiece of Claim 167, wherein the oxide layer has a thickness between about 5 angstroms and 100 nm.

169. The workpiece of Claim 168, wherein the oxide layer has a thickness between about 20 angstroms and 10 nm.

170. The workpiece of Claim 167, wherein the oxide layer has a thickness between about 1 and 2 nm.

171. A method for processing comprising:

providing a workpiece comprising a first transfer layer; and

depositing material on regions of the first transfer layer using a particle beam thereby forming on the first transfer layer a layer having a pattern,

wherein the first transfer layer is configured to be selectively processed relative to the patterned layer using a first removal process that removes regions of the first transfer layer having a shape substantially determined by the shape of the deposited regions of the patterned layer.

172. The method of Claim 171, further comprising a second transfer layer configured to be selectively processed relative to the first transfer layer using a second removal process that removes regions of the second transfer layer having a shape substantially determined by the shape of the deposited regions of the patterned layer.

173. The method of Claim 172, wherein the first transfer layer is configured to be selectively processed relative to the second transfer layer using said first removal process.

174. The method of Claim 172, wherein the second transfer layer is about 1 to 1000 nm thick.

175. The method of Claim 174, wherein the second transfer layer is about 5 to 500 nm thick.

176. The method of Claim 175, wherein the second transfer layer is about 10 to 200 nm thick.

177. The method of Claim 172, wherein the second transfer layer comprises organic material.

178. The method of Claim 172, wherein the first transfer layer is thinner than the second transfer layer.

179. The method of Claim 172, wherein the first transfer layer is about 1 to 1000 nm thick.

180. The method of Claim 179, wherein the first transfer layer is about 5 to 500 nm thick.

181. The method of Claim 180, wherein the first transfer layer is about 10 to 200 nm thick.

182. The method of Claim 179, wherein the first transfer layer is about 1 to 20 nm thick.

183. The method of Claim 172, wherein the first transfer layer comprises titanium.

184. The method of Claim 172, wherein the first transfer layer comprises silicon.

185. The method of Claim 171, wherein the pattern layer is about 0.1 angstroms monolayer to 200 nm thick.

186. The method of Claim 185, wherein the pattern layer is about 5 angstroms to 100 nm thick.

187. The method of Claim 186, wherein the pattern layer is about 20 angstroms to 10 nm thick.

188. The method of Claim 185, wherein the pattern layer is about 1 to 2 nm thick.

189. The method of Claim 171, wherein the first removal process comprises an etch process.

190. The method of Claim 189, wherein the first removal process comprises a dry etch.

191. The method of Claim 190, wherein the first removal process comprises reactive ion etch.

192. The method of Claim 172, wherein the second removal process comprises an etch process.

193. The method of Claim 192, wherein the second removal process comprises a dry etch.

194. The method of Claim 193, wherein the second removal process comprises reactive ion etch.

195. The method of Claim 171, wherein the first transfer layer is about 1 to 1000 nm thick.

196. The method of Claim 195, wherein the first transfer layer is about 5 to 500 nm thick.

197. The method of Claim 196, wherein the first transfer layer is about 10 to 200 nm thick.

198. The method of Claim 171, wherein the first transfer layer comprises organic material.

199. The method of Claim 171, wherein the particle beam comprises a collimated beam of spatially and temporally resolved charged particles.

200. The method of Claim 171, the selectivity of the first removal process to the first transfer layer relative to the patterned layer being at least 2x.

201. The method of Claim 200, the selectivity of the first removal process to the first transfer layer relative to the patterned layer being at least 10x.

202. The method of Claim 201, the selectivity of the first removal process to the first transfer layer relative to the patterned layer being at least 50x.

203. The method of Claim 202, the selectivity of the first removal process to the first transfer layer relative to the patterned layer being at least 100x.

204. The method of Claim 203, the selectivity of the first removal process to the first transfer layer relative to the patterned layer being at least 500x.

205. The method of Claim 172, wherein the selectivity of the second removal process to the second transfer layer relative to the first transfer layer is at least 2x.

206. The method of Claim 205, wherein the selectivity of the second removal process to the second transfer layer relative to the first transfer layer is at least 10x.

207. The method of Claim 206, wherein the selectivity of the second removal process to the second transfer layer relative to the first transfer layer is at least 50x.

208. The method of Claim 207, wherein the selectivity of the second removal process to the second transfer layer relative to the first transfer layer is at least 100x.

209. The method of Claim 208, wherein the selectivity of the second removal process to the second transfer layer relative to the first transfer layer is at least 500x.

210. The method of Claim 1, wherein the workpiece comprises a semiconductor wafer.

211. The method of Claim 1, wherein the workpiece comprises a photomask.

212. The method of Claim 1, wherein the workpiece comprises a data storage disk.

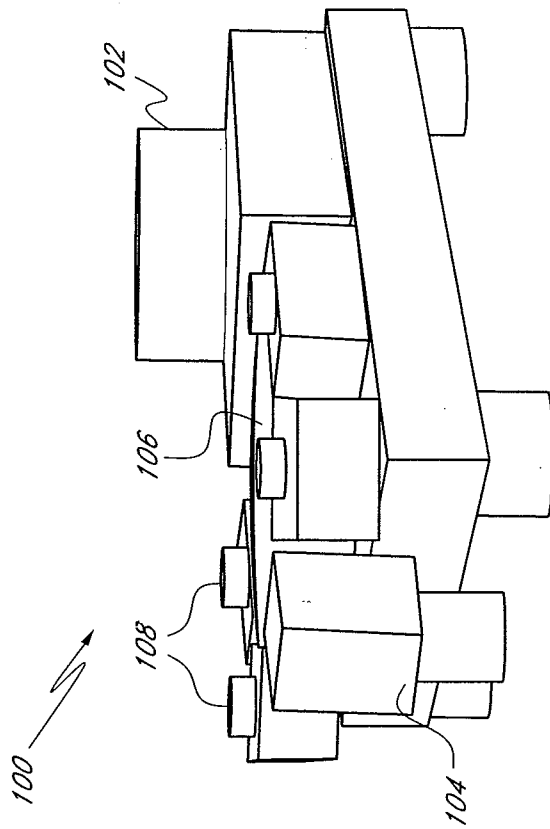

FIG. 1A

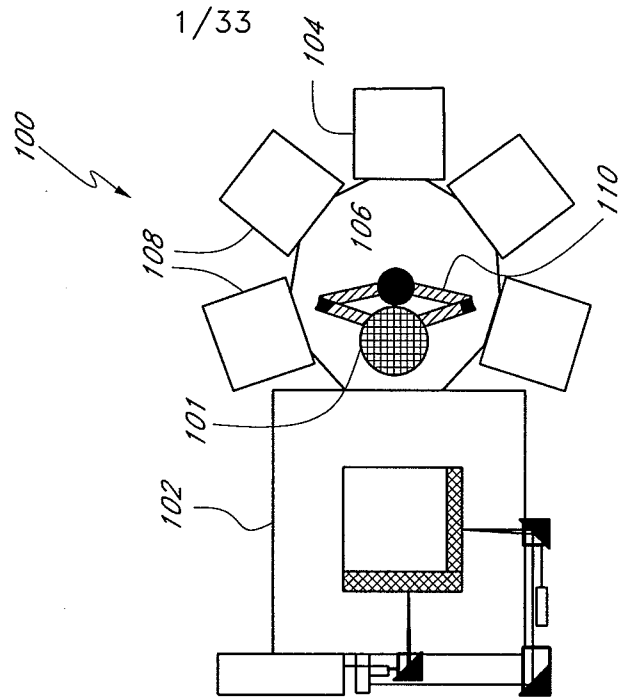

FIG. 1B

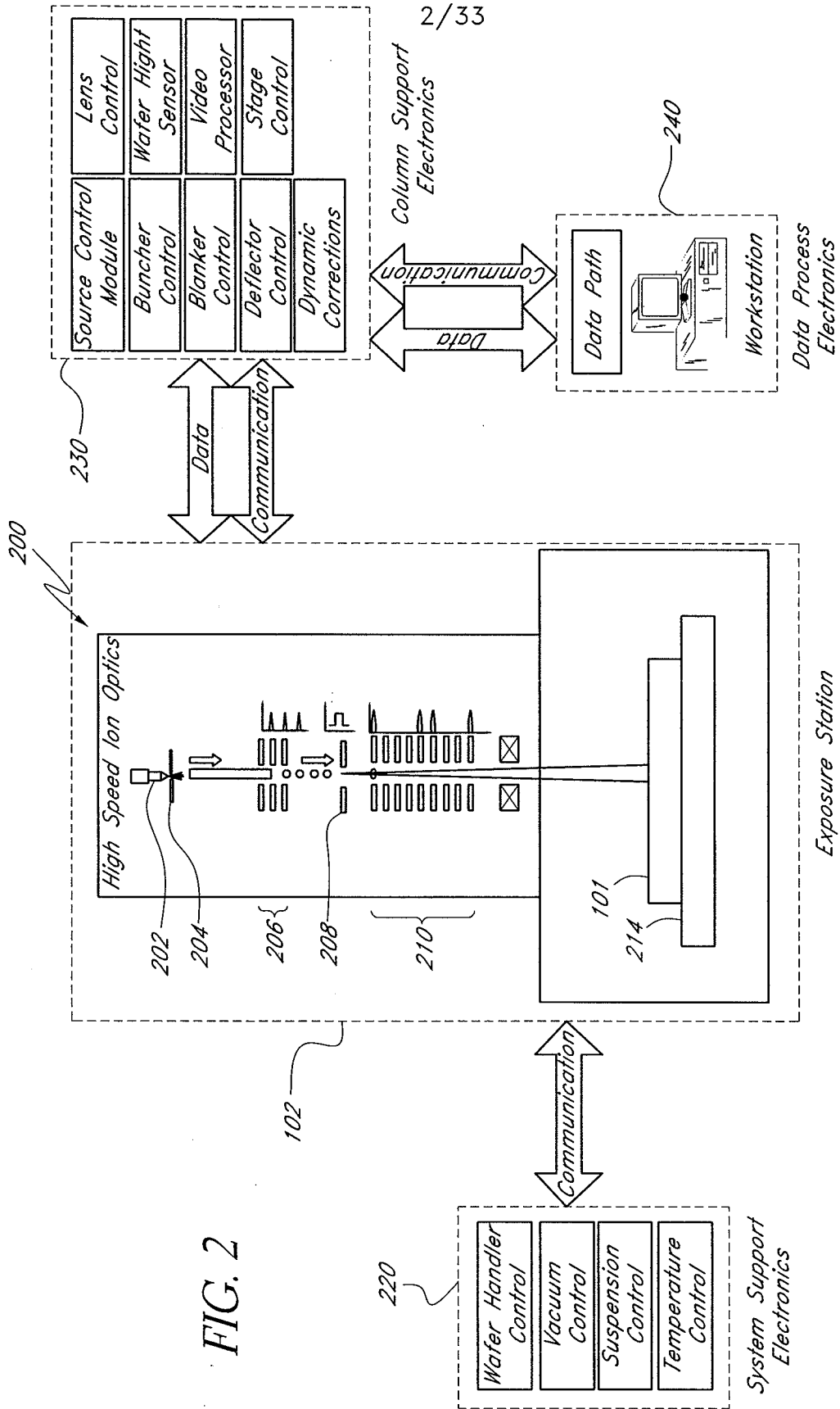

FIG. 2

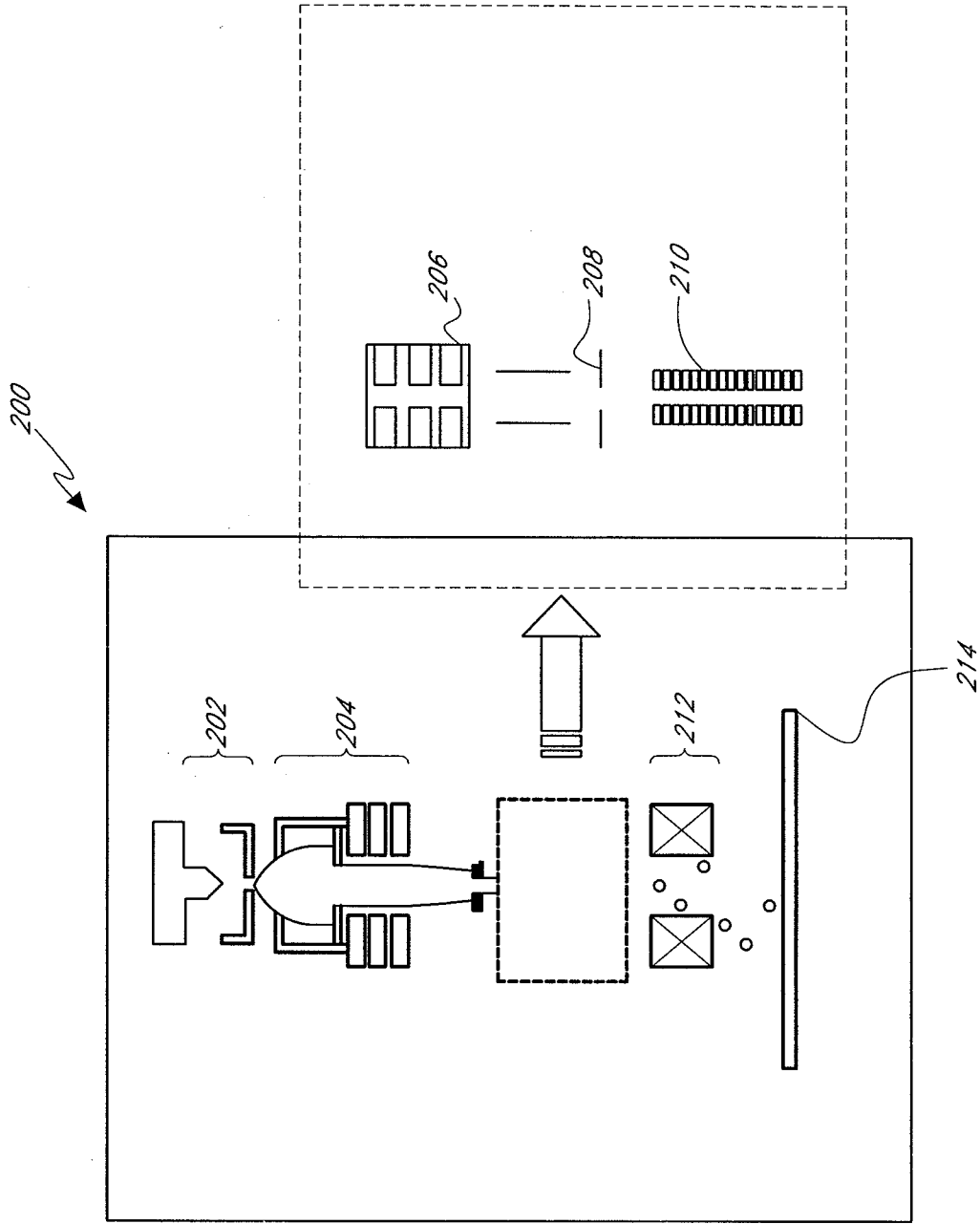

FIG. 3A

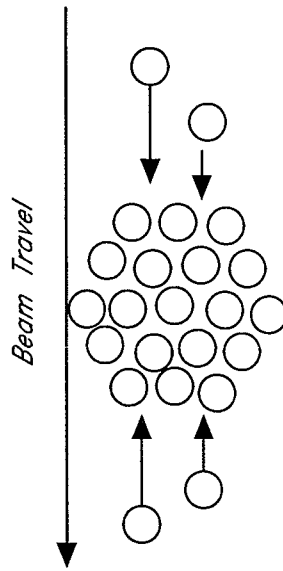

FIG. 3B

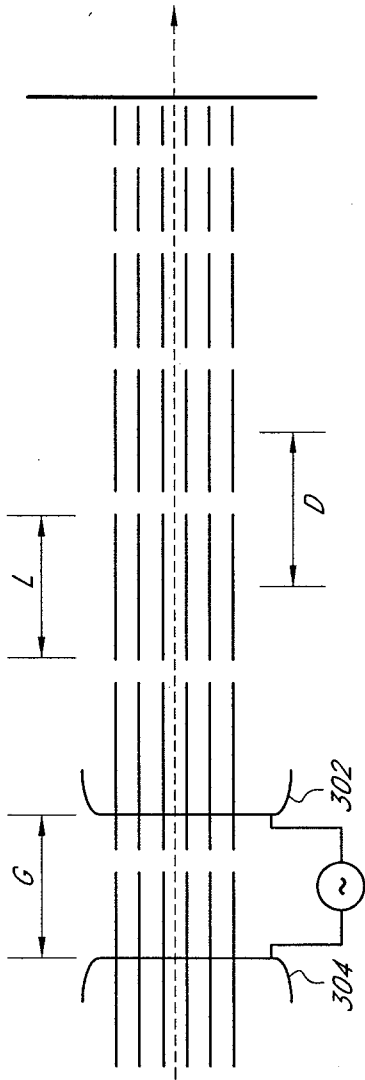

FIG. 3C

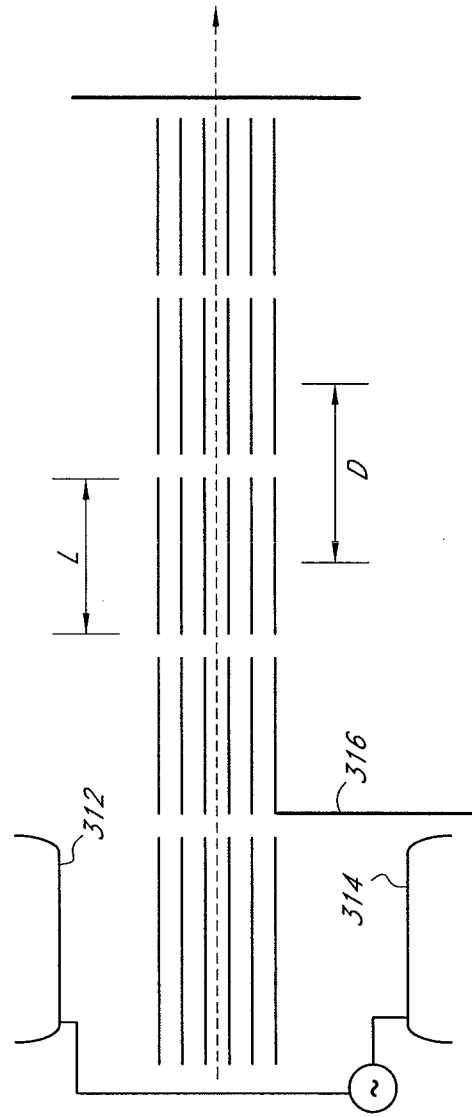

FIG. 3D

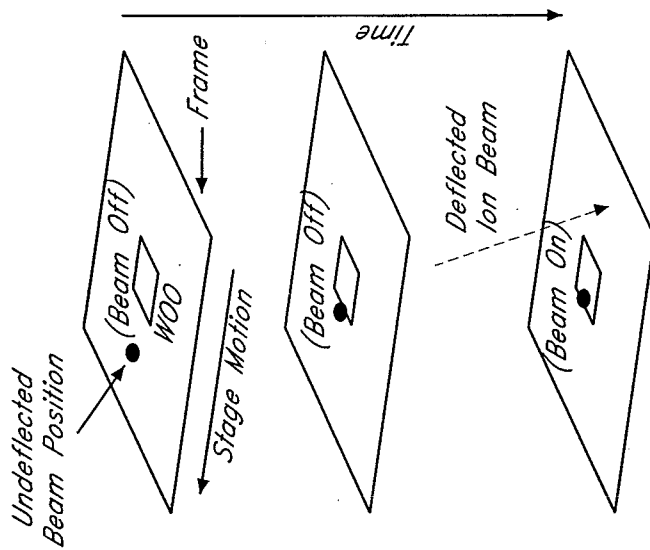

FIG. 4A

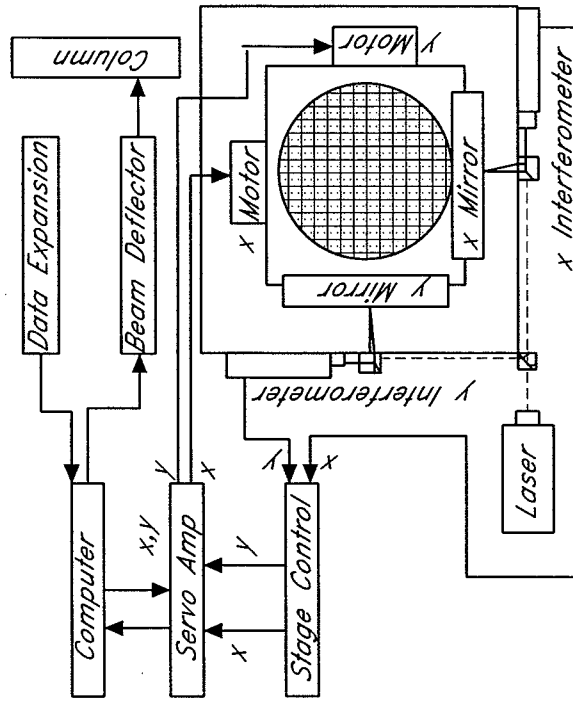

FIG. 4B

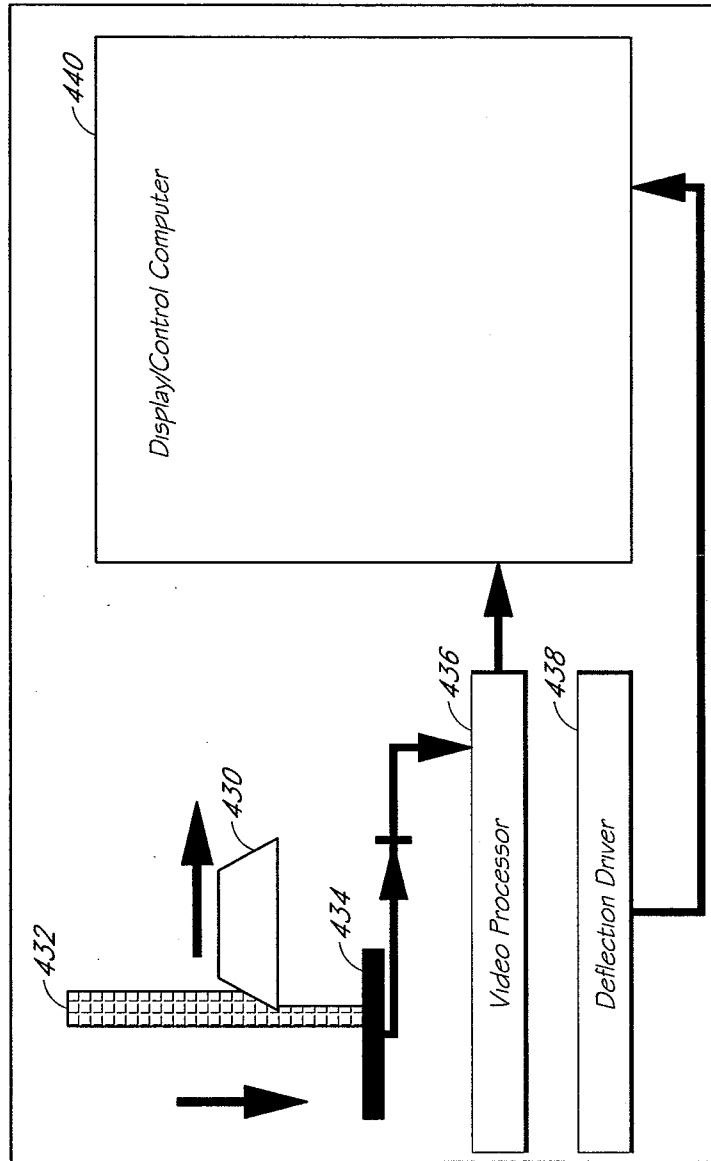

FIG. 4C

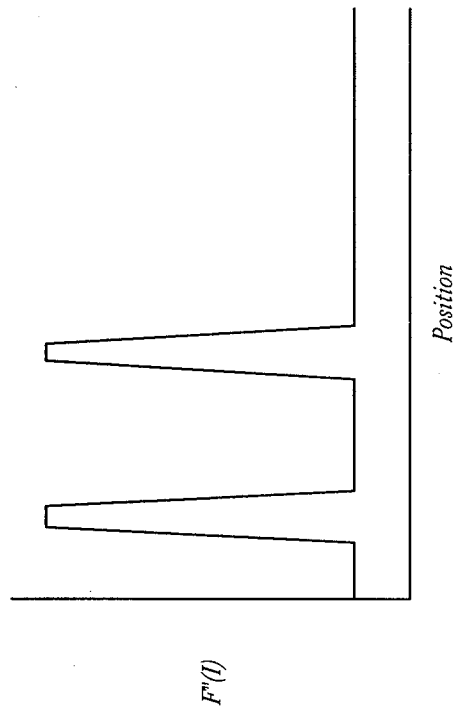
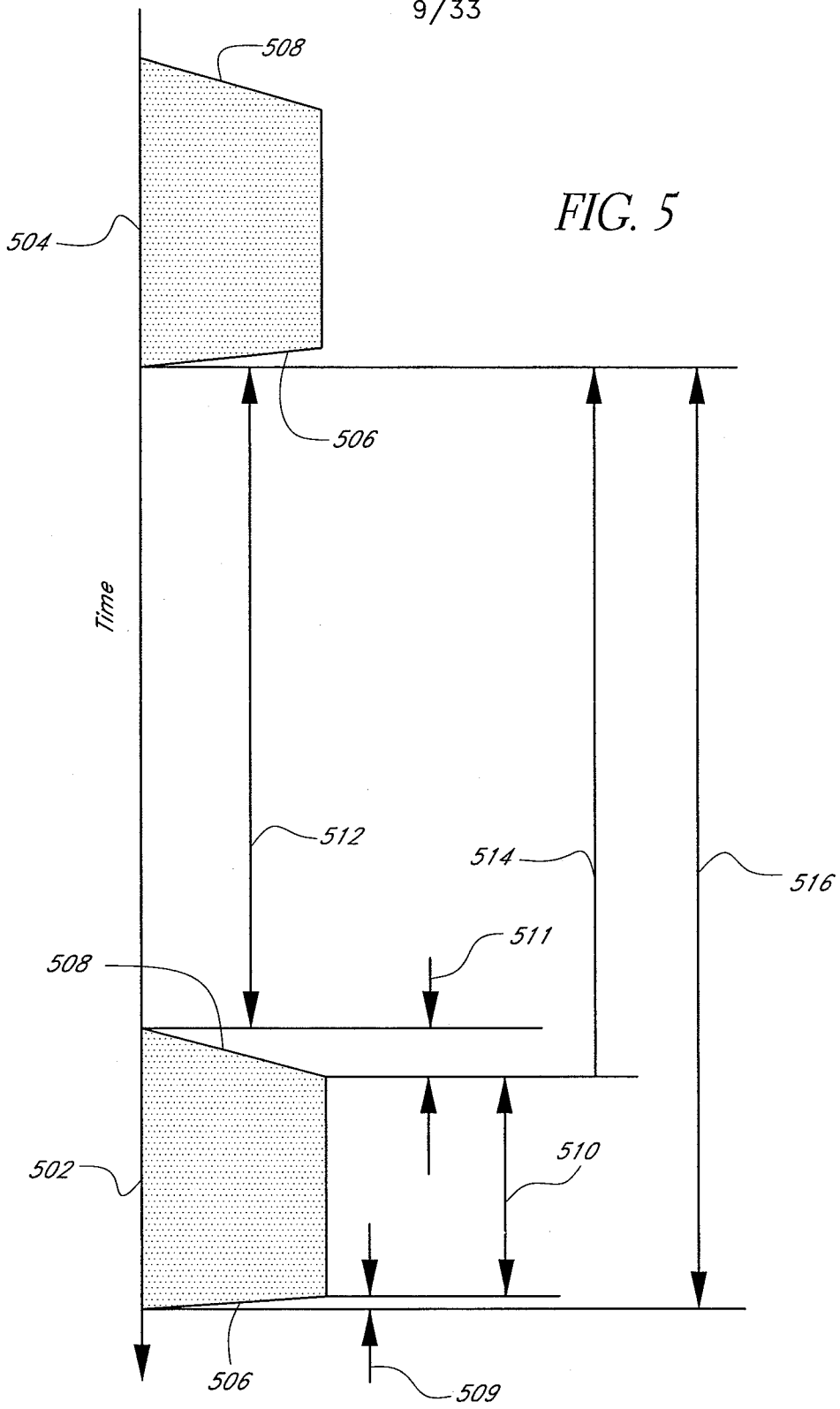

FIG. 4D



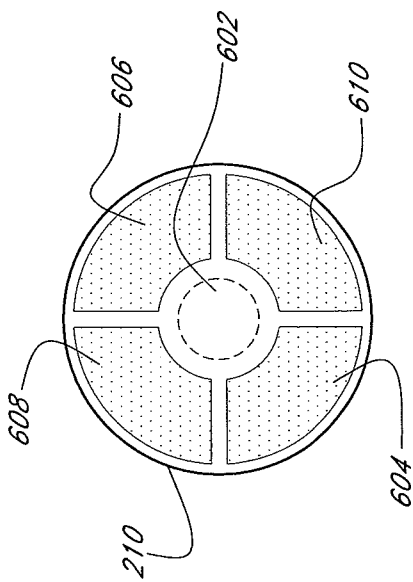

FIG. 6A

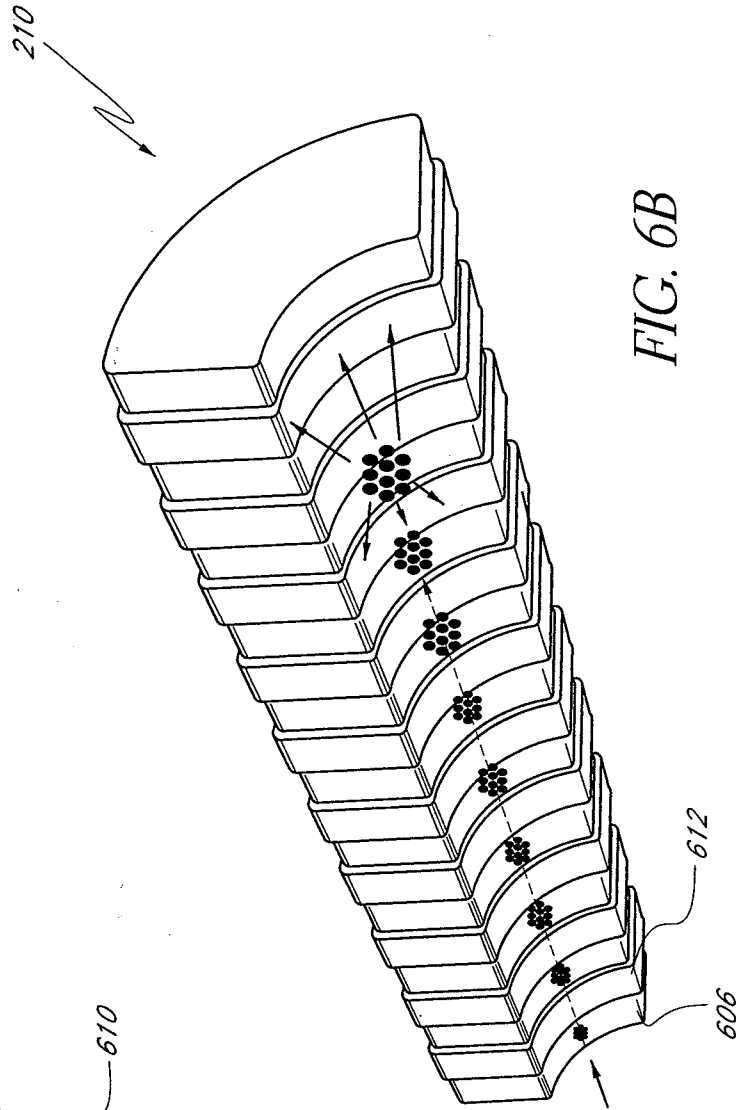

FIG. 6B

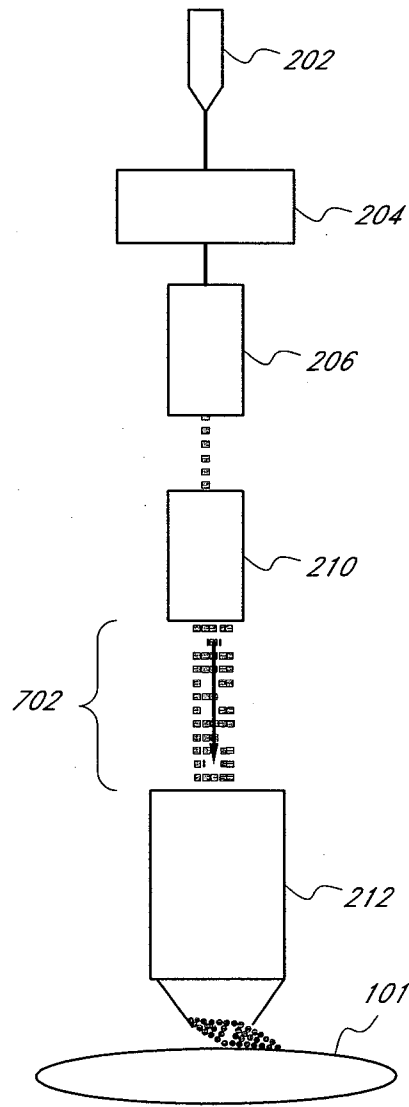

FIG. 7

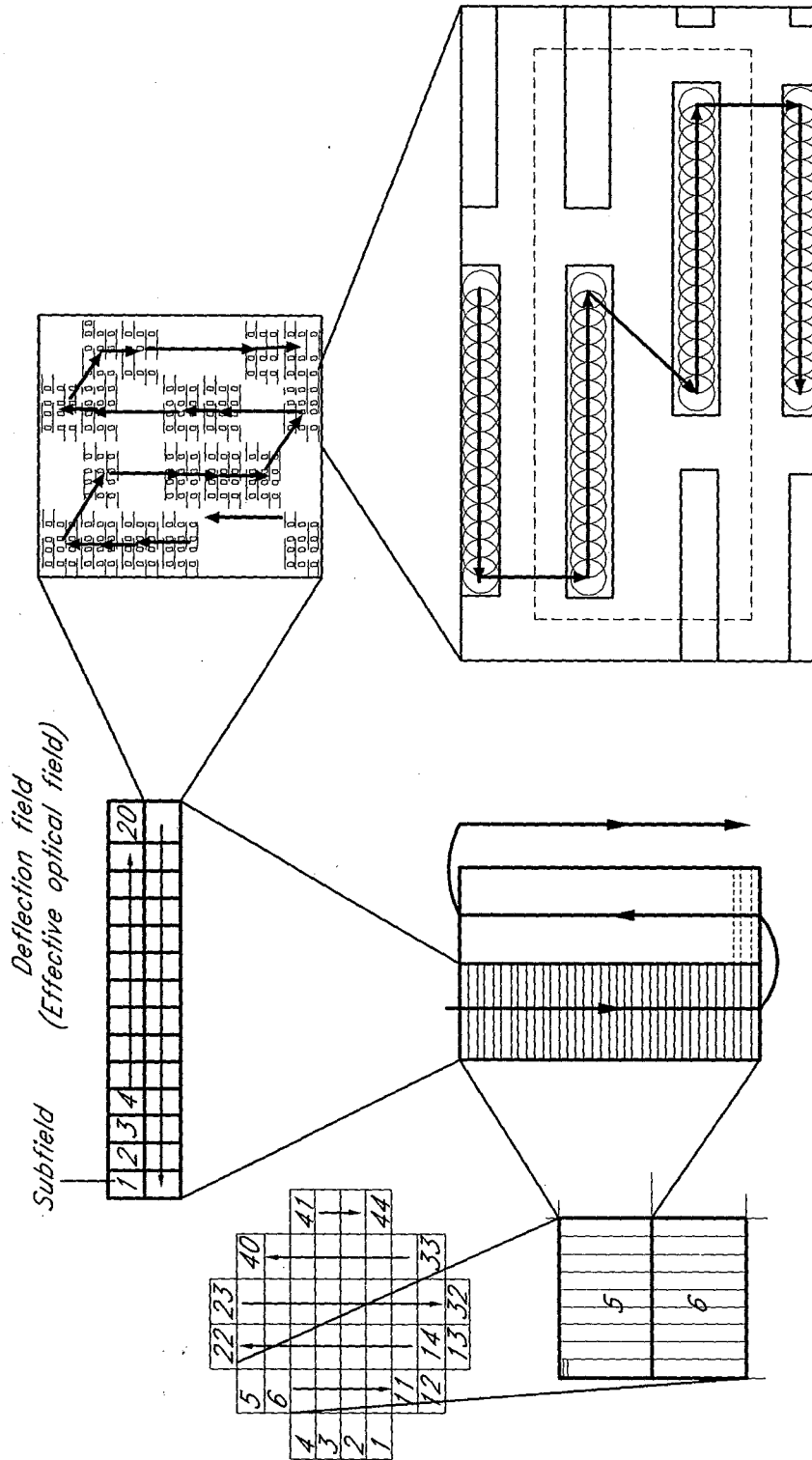
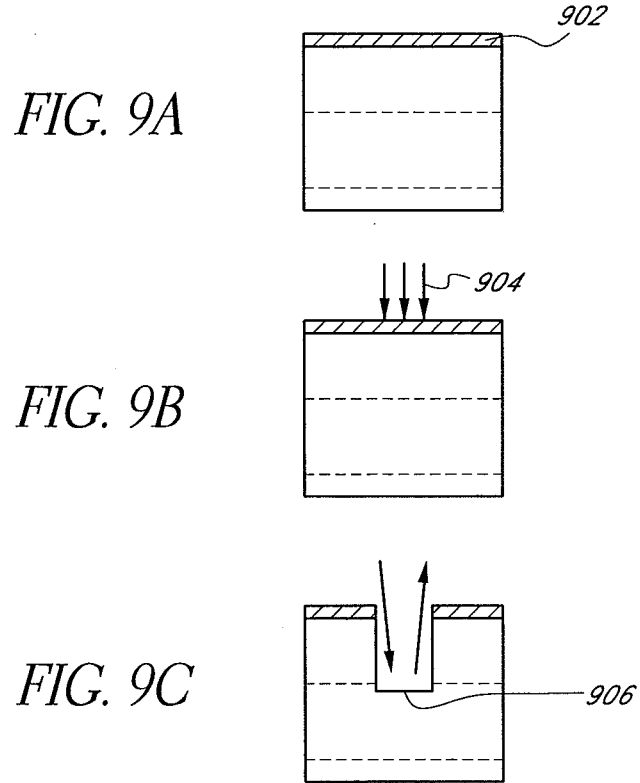

FIG. 8



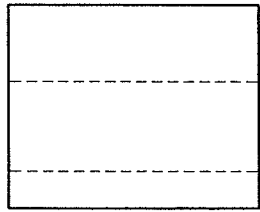

FIG. 10A

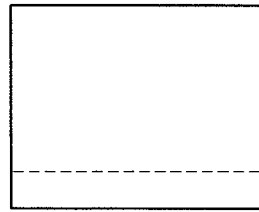

FIG. 11A

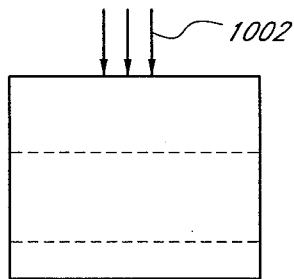

FIG. 10B

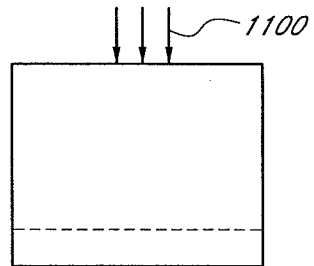

FIG. 11B

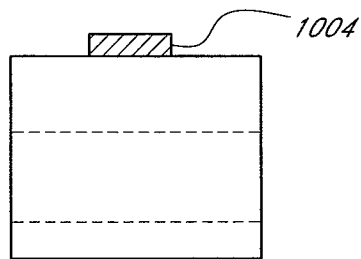

FIG. 10C

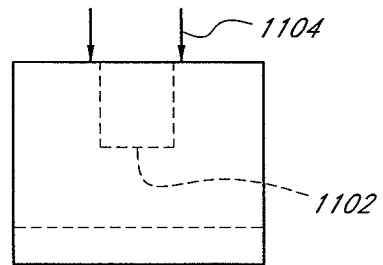

FIG. 11C

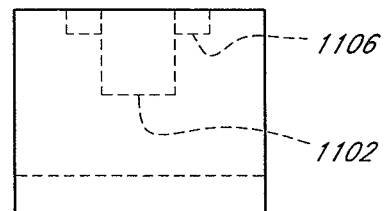

FIG. 11D

15/33

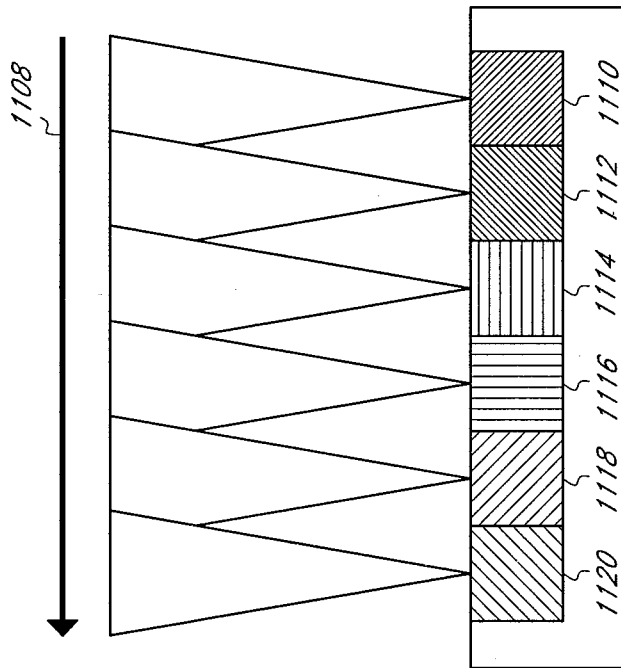

FIG. 11E

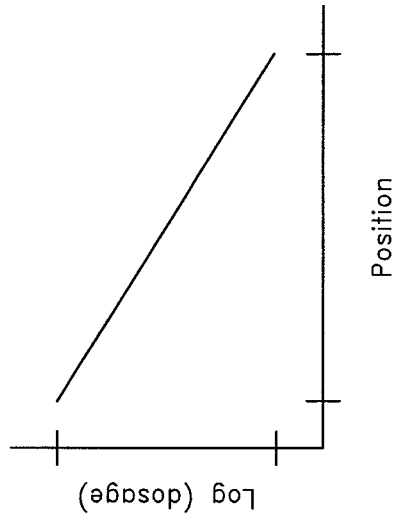

FIG. 11F

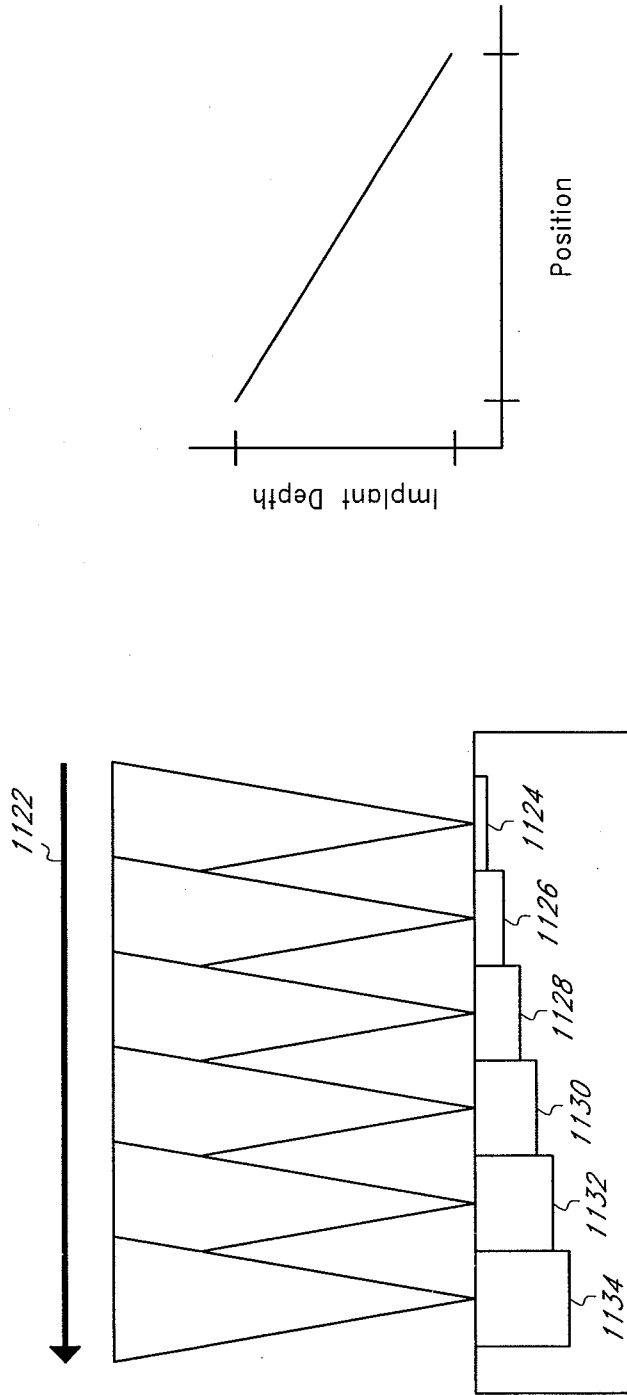

FIG. 11H

FIG. 11G

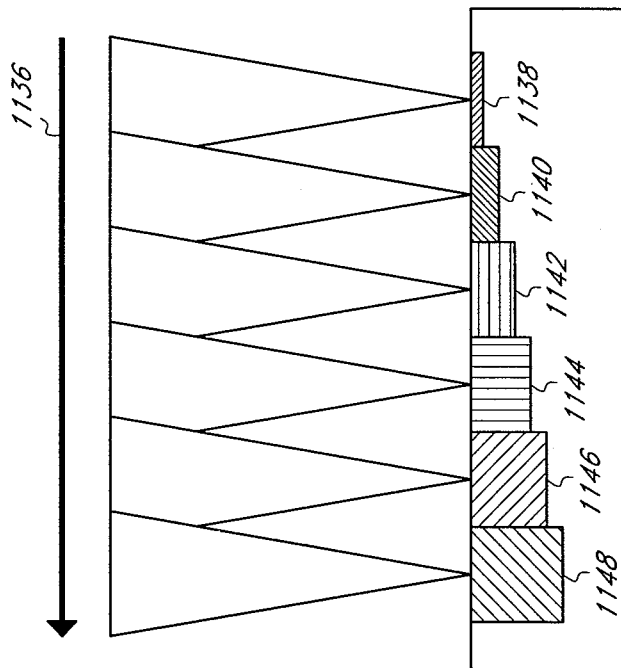

FIG. 111

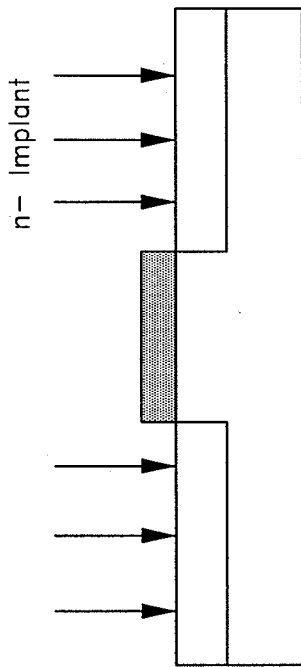

FIG. 12A

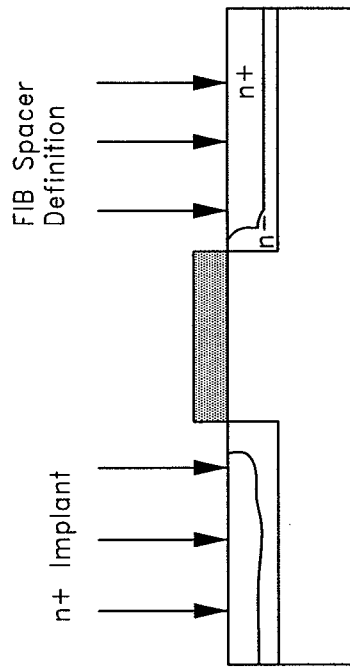

FIG. 12B

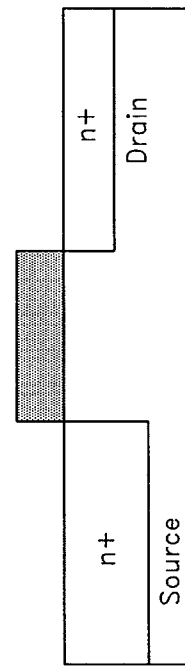

FIG. 12C

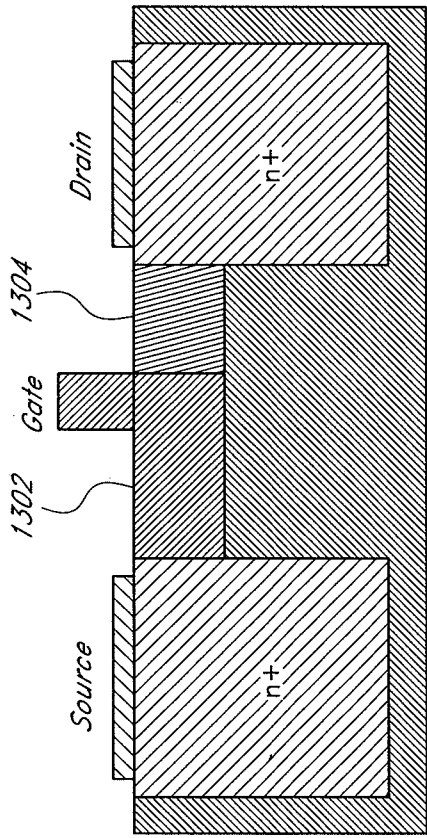

FIG. 13A

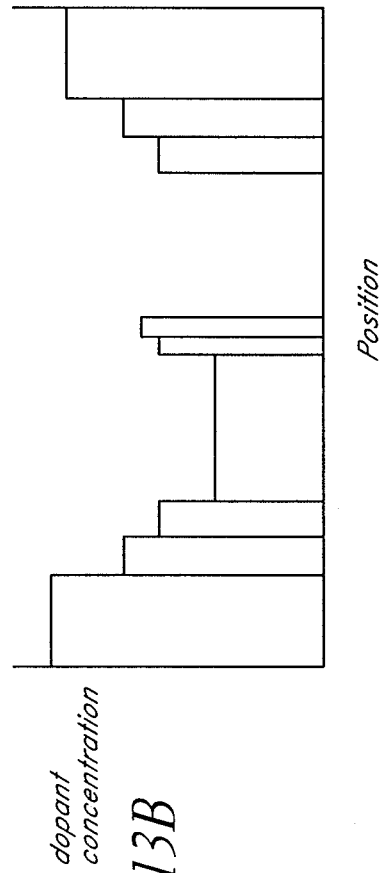

FIG. 13B

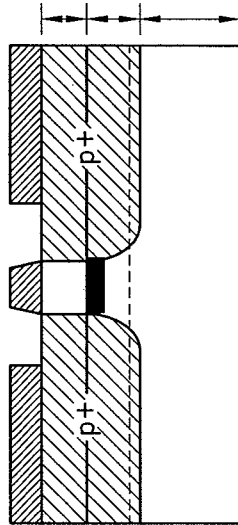

FIG. 14B

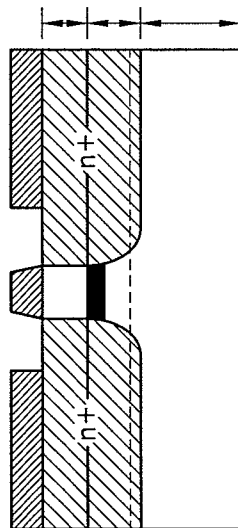

FIG. 14A

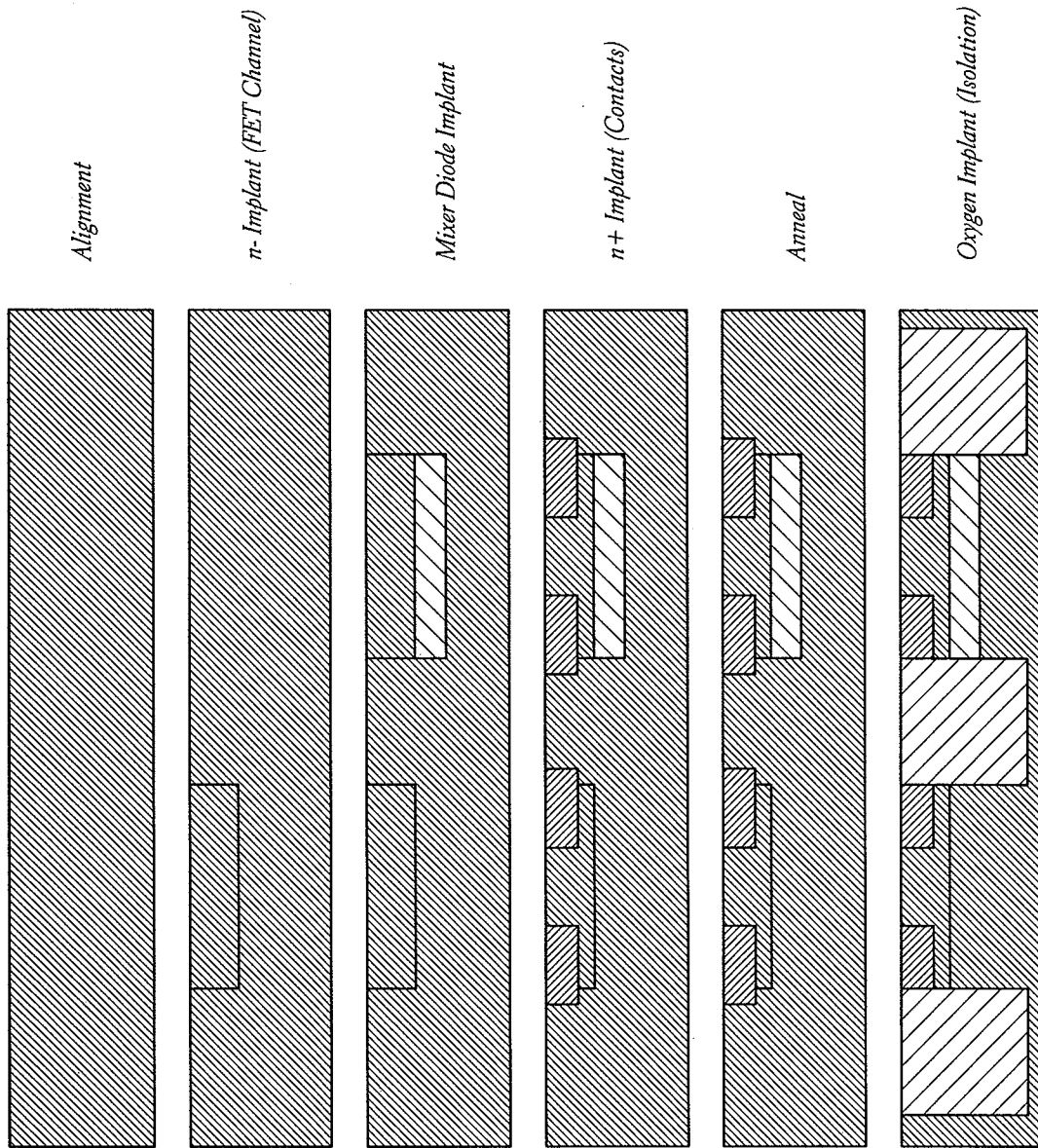

FIG. 15

FIG. 16A



FIG. 16B

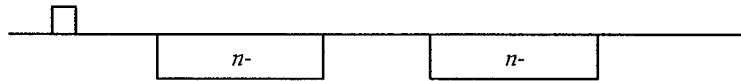

FIG. 16C

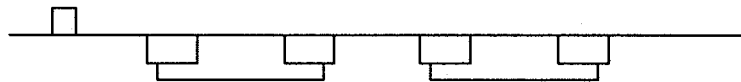

FIG. 16D

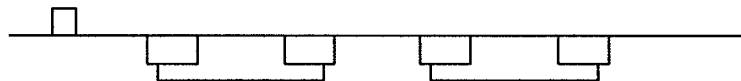
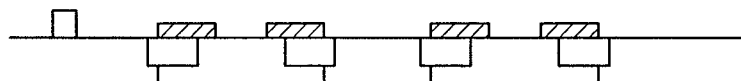
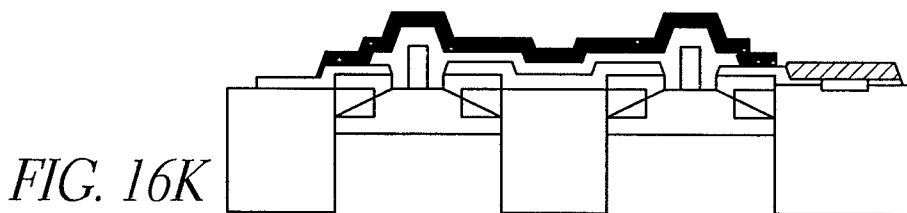
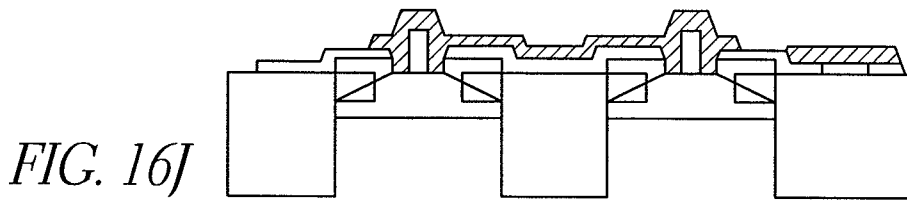
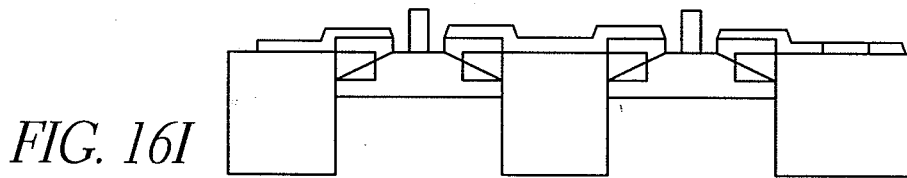
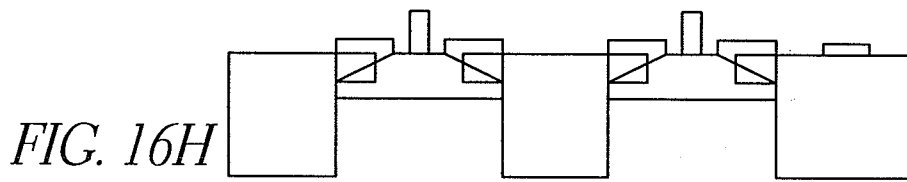
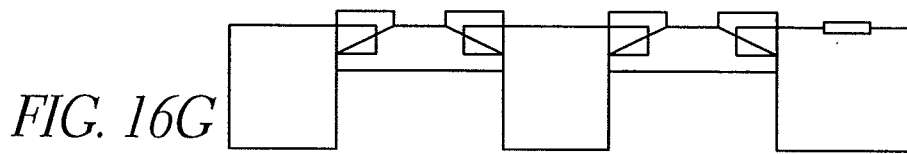
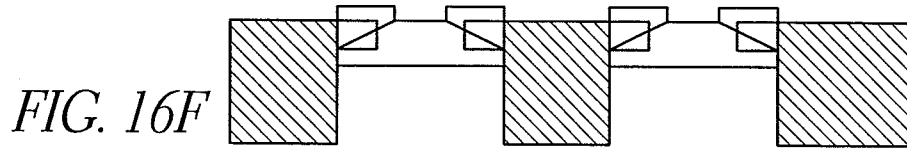

FIG. 16E





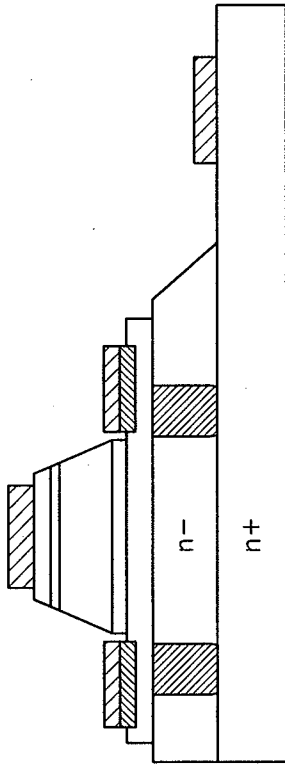

FIG. 17

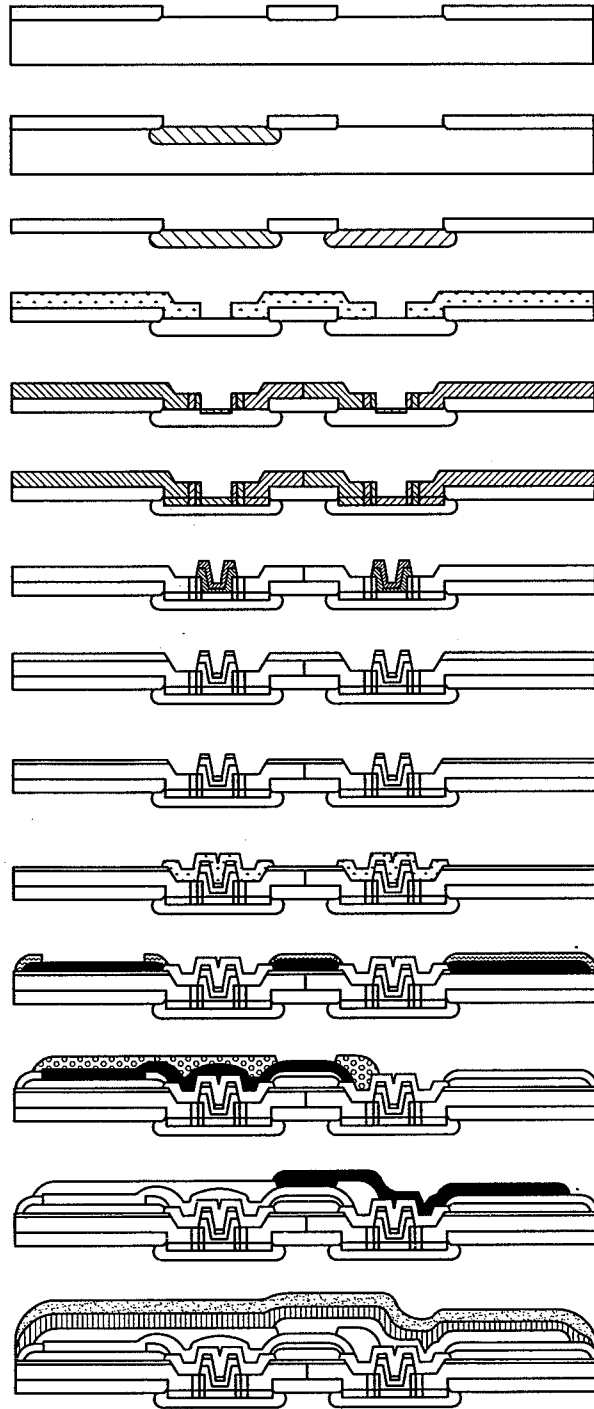

FIG. 18

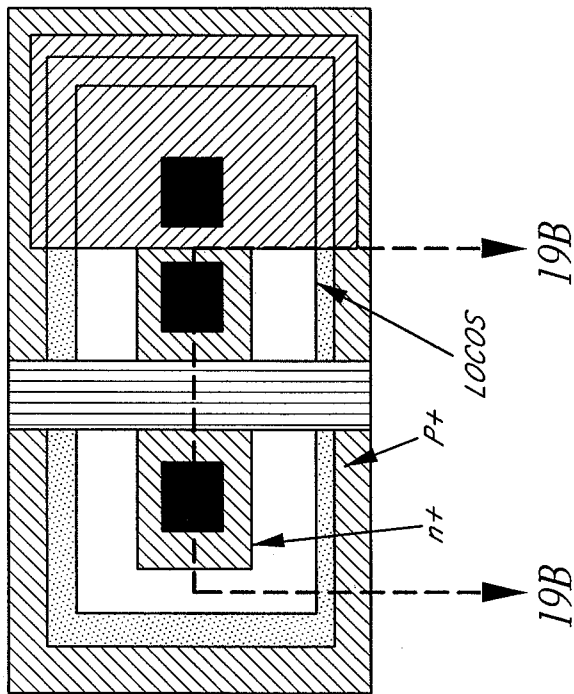

FIG. 19A

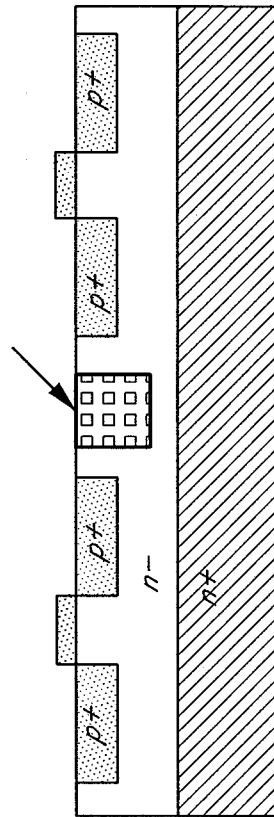

FIG. 19B

27/33

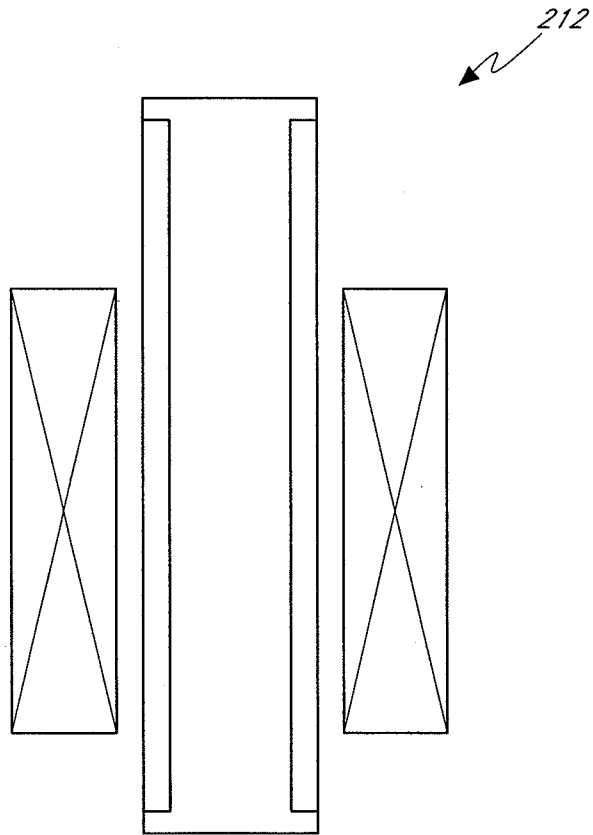

FIG. 20

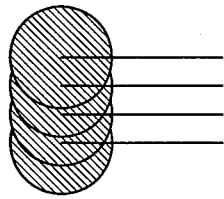

FIG. 21A

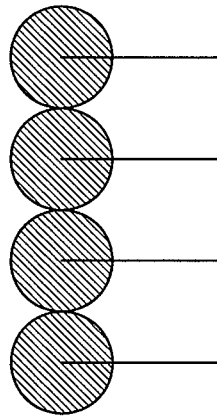

FIG. 21B

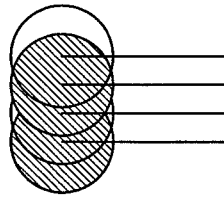

FIG. 21C

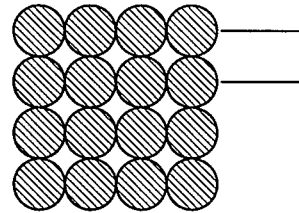
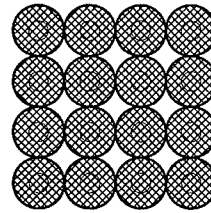
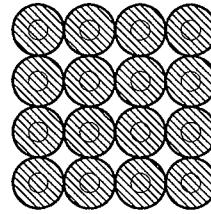
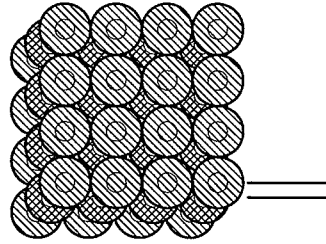

FIG. 21D

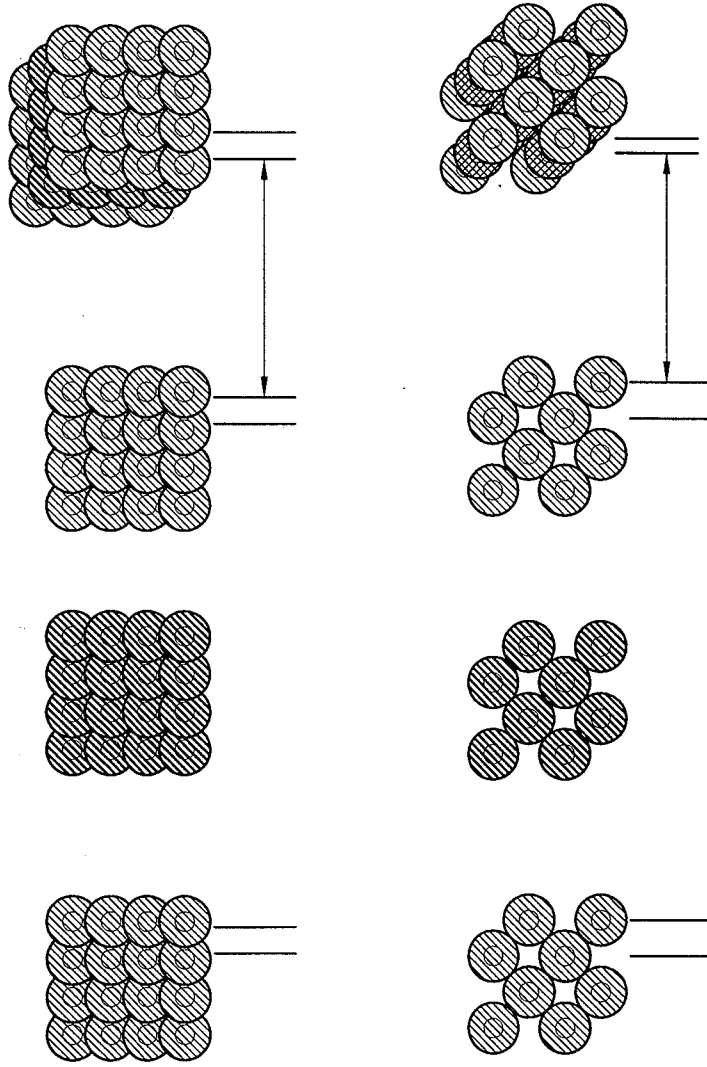

FIG. 21E

FIG. 21F

31/33

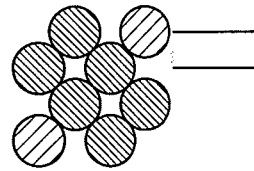
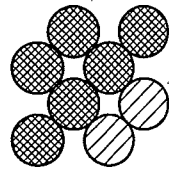
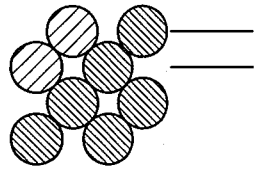
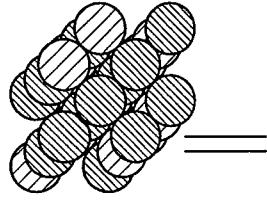

FIG. 21G

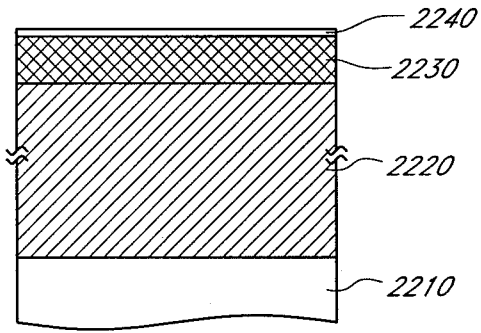

FIG. 22A

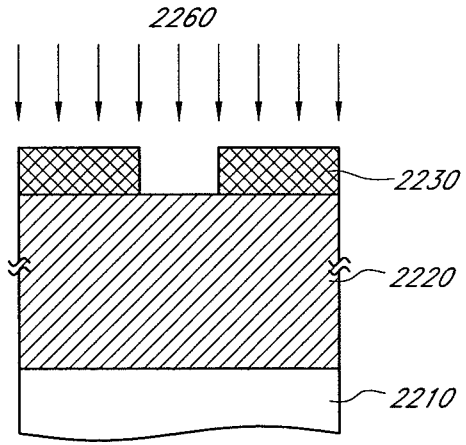

FIG. 22C

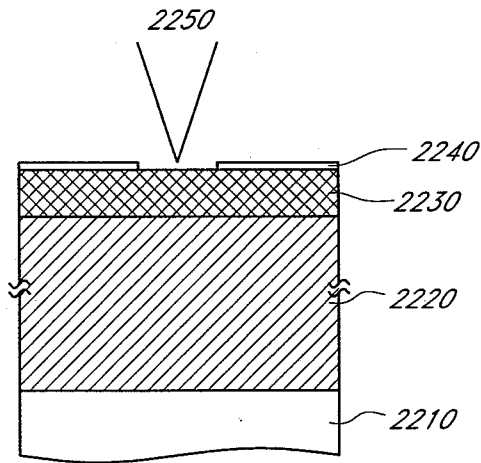

FIG. 22B

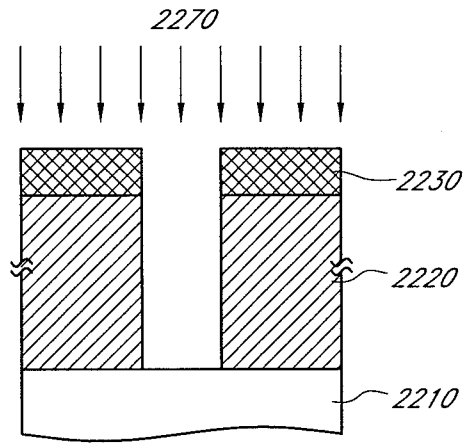

FIG. 22D

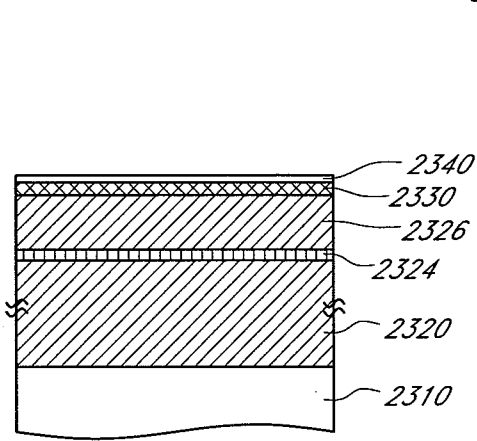

FIG. 23A

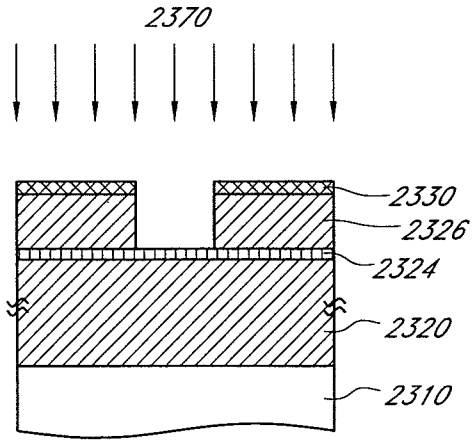

FIG. 23D

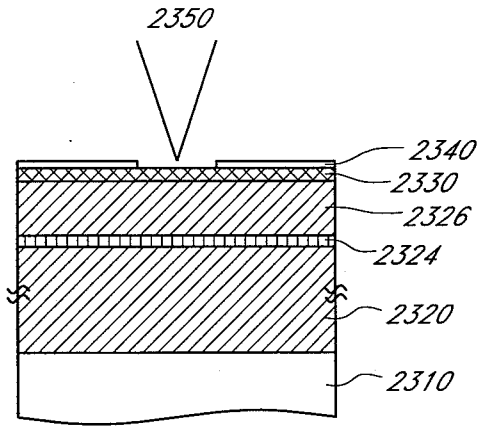

FIG. 23B

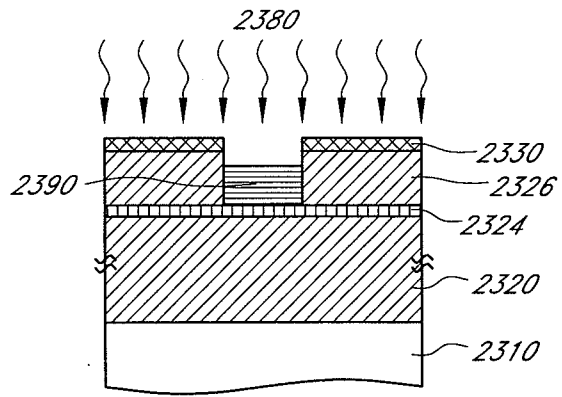

FIG. 23E

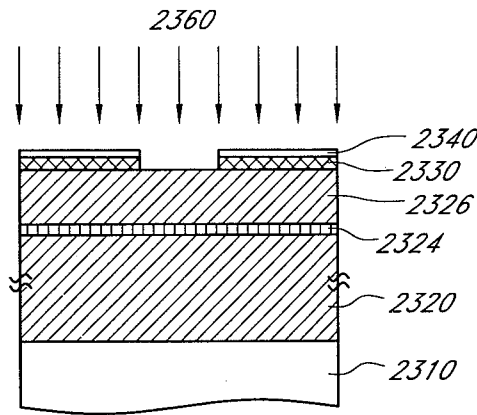

FIG. 23C

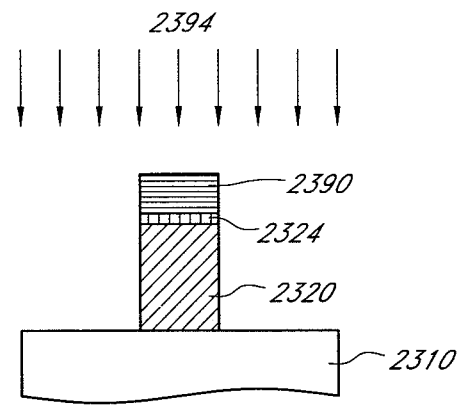

FIG. 23F

INTERNATIONAL SEARCH REPORT

International application No.
PCT/US 07/85447

A. CLASSIFICATION OF SUBJECT MATTER
 IPC(8) - G03F 1/00; G03C 5/00; H01L 21/302 (2008.04)
 USPC - 430/5, 296; 438/712
 According to International Patent Classification (IPC) or to both national classification and IPC

B. FIELDS SEARCHED
 Minimum documentation searched (classification system followed by classification symbols)
 IPC(8) - G03F 1/00; G03C 5/00; H01L 21/302 (2008.04)
 USPC - 430/5, 296; 438/712

Documentation searched other than minimum documentation to the extent that such documents are included in the fields searched
 USPC - 430/5, 296; 438/712 (text search - see terms below)

Electronic data base consulted during the international search (name of data base and, where practicable, search terms used)
 PubWEST(USPT, PGPB, EPAB, JPAB); Google Scholar (Patents); DialogPro (General Research)
 substrate, layer, particle, beam, pattern, remove, expose, collimate, shape, transfer, thick, nm, organic, metal, Si, angstrom, oxide, alumina, adsorb, atom, molecule, fluid, etch, spatial, temporal, sputter yield, UV, develop, fourth, 2X

C. DOCUMENTS CONSIDERED TO BE RELEVANT

| Category* | Citation of document, with indication, where appropriate, of the relevant passages | Relevant to claim No. |
|---------------|---|---|
| X --- Y | US 6,605,816 B2 (Sandstrom) 12 August 2003 (12.08.2003) abstract, col 5, ln 1-67, col 6, ln 1-41, col 7, ln 1-67, col 8, ln 1-36, col 9, ln 13-67, col 10, ln 37-67, col 11, ln 1-67, col 12, ln 1-67, col 13, ln 1-19, ln 49-67, col 14, col 15, ln 48-67, col 16, ln 10-23. | 1-13, 18-21, 24-40, 47-66, 79-98, 101-104, 106-128, 136-152, 157-160 and 210-212 14-17, 22-23, 41-46, 67-78, 99-10, 105, 129-135, 153-156, 161-209 |
| Y | US 2004/0178170 A1 (Morimoto) 16 September 2004 (16.09.2004) para [0039], para [0042], para [0043], para [0037] | 14-17, 22-23, 67-74, 99, 100, 105, 153-156, 165, 167-170, 183-184 |
| Y | US 6,835,289 B2 (Yamashita) 28 December 2004 (28.12.2004) col 4, ln 13-17 | 41-46, 129-135 |
| Y | US 2004/0150068 A1 (Leedy) 05 August 2004 (05.08.2004) para [0122], para [0290], para [0312], para [0292] | 75-78, 161-164, 171-182, 185-209, 183-184 |
| Y | US 4,323,638 A (Adams et al.) 06 April 1982 (06.04.1982) col 4, ln 20-26 | 166 |

Further documents are listed in the continuation of Box C.

- * Special categories of cited documents:
- "A" document defining the general state of the art which is not considered to be of particular relevance
- "E" earlier application or patent but published on or after the international filing date
- "L" document which may throw doubts on priority claim(s) or which is cited to establish the publication date of another citation or other special reason (as specified)
- "O" document referring to an oral disclosure, use, exhibition or other means
- "P" document published prior to the international filing date but later than the priority date claimed
- "T" later document published after the international filing date or priority date and not in conflict with the application but cited to understand the principle or theory underlying the invention
- "X" document of particular relevance; the claimed invention cannot be considered novel or cannot be considered to involve an inventive step when the document is taken alone
- "Y" document of particular relevance; the claimed invention cannot be considered to involve an inventive step when the document is combined with one or more other such documents, such combination being obvious to a person skilled in the art
- "&" document member of the same patent family

| | |
|---|--|
| Date of the actual completion of the international search 30 September 2008 (30.09.2008) | Date of mailing of the international search report 20 OCT 2008 |
|---|--|

| | |
|---|--|
| Name and mailing address of the ISA/US Mail Stop PCT, Attn: ISA/US, Commissioner for Patents P.O. Box 1450, Alexandria, Virginia 22313-1450 Facsimile No. 571-273-3201 | Authorized officer: Lee W. Young PCT Helpdesk: 571-272-4300 PCT OSP: 571-272-7774 |
|---|--|