



(43) International Publication Date
30 December 2015 (30.12.2015)

- (51) International Patent Classification:
H02J 9/06 (2006.01)
- (21) International Application Number:
PCT/US2015/037343
- (22) International Filing Date:
24 June 2015 (24.06.2015)
- (25) Filing Language: English
- (26) Publication Language: English
- (30) Priority Data:
62/017,028 25 June 2014 (25.06.2014) US
- (71) Applicant: EMERSON NETWORK POWER, ENERGY SYSTEMS, NORTH AMERICA, INC. [US/US];
4350 Weaver Parkway, Warrenville, IL 60555 (US).
- (72) Inventor: SMITH, Michael, Francis; 4350 Weaver Parkway, Warrenville, IL 60555 (US).
- (74) Agents: THOMAS, Michael, J. et al.; Harness, Dickey & Pierce, P.L.C., 7700 Bonhomme Avenue, Suite 400, St. Louis, Missouri 63105 (US).

- (81) Designated States (unless otherwise indicated, for every kind of national protection available): AE, AG, AL, AM, AO, AT, AU, AZ, BA, BB, BG, BH, BN, BR, BW, BY, BZ, CA, CH, CL, CN, CO, CR, CU, CZ, DE, DK, DM, DO, DZ, EC, EE, EG, ES, FI, GB, GD, GE, GH, GM, GT, HN, HR, HU, ID, IL, IN, IR, IS, JP, KE, KG, KN, KP, KR, KZ, LA, LC, LK, LR, LS, LU, LY, MA, MD, ME, MG, MK, MN, MW, MX, MY, MZ, NA, NG, NI, NO, NZ, OM, PA, PE, PG, PH, PL, PT, QA, RO, RS, RU, RW, SA, SC, SD, SE, SG, SK, SL, SM, ST, SV, SY, TH, TJ, TM, TN, TR, TT, TZ, UA, UG, US, UZ, VC, VN, ZA, ZM, ZW.
- (84) Designated States (unless otherwise indicated, for every kind of regional protection available): ARIPO (BW, GH, GM, KE, LR, LS, MW, MZ, NA, RW, SD, SL, ST, SZ, TZ, UG, ZM, ZW), Eurasian (AM, AZ, BY, KG, KZ, RU, TJ, TM), European (AL, AT, BE, BG, CH, CY, CZ, DE, DK, EE, ES, FI, FR, GB, GR, HR, HU, IE, IS, IT, LT, LU, LV, MC, MK, MT, NL, NO, PL, PT, RO, RS, SE, SI, SK, SM, TR), OAPI (BF, BJ, CF, CG, CI, CM, GA, GN, GQ, GW, KM, ML, MR, NE, SN, TD, TG).

Published:

— with international search report (Art. 21(3))

(54) Title: BATTERY BACKUP UNITS AND SYSTEMS INCLUDING BYPASSING CIRCUITRY FOR REGULATING OUTPUTS

Fig. 1

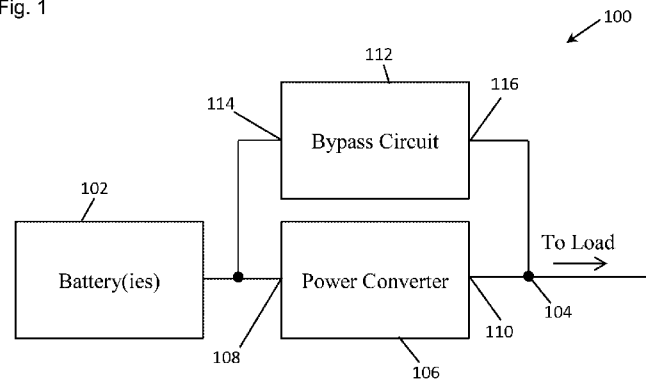

(57) Abstract: A battery backup unit (BBU) for supplying backup power to a load includes at least one battery, an output terminal for coupling to a load, a power converter having an input coupled to the at least one battery and an output coupled to the output terminal, and a bypass circuit having an input coupled to the at least one battery and an output coupled to the output terminal. The power converter is configured to regulate a voltage at the output terminal after startup of the power converter. The bypass circuit is configured to regulate the voltage at the output terminal during startup of the power converter. Other example systems including one or more BBUs are also disclosed.

WO 2015/200437 A1

BATTERY BACKUP UNITS AND SYSTEMS INCLUDING BYPASSING
CIRCUITRY FOR REGULATING OUTPUTS

CROSS-REFERENCE TO RELATED APPLICATION

[0001] This application is a PCT International Application and claims the benefit of United States Patent Application No. 62/017,028 filed June 25, 2014.

FIELD

[0002] The present disclosure relates to battery backup units and systems including bypassing circuitry for regulating outputs.

BACKGROUND

[0003] This section provides background information related to the present disclosure which is not necessarily prior art.

[0004] Power systems may include a primary power source and a backup power source for powering a load. When it is determined the primary power source cannot provide adequate power to the load, the backup power source may be activated to temporarily provide backup power to the load. Typically, the backup power source includes an output converter that regulates its output voltage after overcoming a transient condition caused by a load current step from zero to a higher value when the backup power source is activated.

SUMMARY

[0005] This section provides a general summary of the disclosure, and is not a comprehensive disclosure of its full scope or all of its features.

[0006] According to one aspect of the present disclosure, a battery backup unit (BBU) for supplying backup power to a load includes at least one battery, an output terminal for coupling to a load, a power converter having an input coupled to the at least one battery and an output coupled to the output terminal, and a bypass circuit having an input coupled to the at least one battery and an output coupled to the output terminal. The power converter is configured to regulate a voltage at the output terminal after startup of the power converter. The bypass circuit is configured to regulate the voltage at the output terminal during startup of the power converter.

[0007] According to another aspect of the present disclosure, a system for supplying power to one or more loads includes a primary power source for supplying a voltage to one or more loads, a BBU for supplying a backup voltage to the one or more loads, and a control circuit. The BBU is coupled to the primary power source. The BBU includes at least one battery, an output terminal for coupling to the one or more loads, a power converter having an input coupled to the at least one battery and an output coupled to the output terminal, and a bypass circuit having an input coupled to the at least one battery and an output coupled to the output terminal. The control circuit is coupled to the power converter and the bypass circuit. The control circuit is configured to control the power converter to regulate the backup voltage at the output terminal after startup of the power converter and to enable the bypass circuit to regulate the backup voltage at the output terminal during startup of the power converter.

[0008] Further aspects and areas of applicability will become apparent from the description provided herein. It should be understood that various aspects of this disclosure may be implemented individually or in combination with one or more other aspects. It should also be understood that the description and specific examples herein are intended for purposes of illustration only and are not intended to limit the scope of the present disclosure.

DRAWINGS

[0009] The drawings described herein are for illustrative purposes only of selected embodiments and not all possible implementations, and are not intended to limit the scope of the present disclosure.

[0010] Fig. 1 is a block diagram of a BBU including a bypass circuit and a power converter, each for regulating a BBU output voltage according to one example embodiment of the present disclosure.

[0011] Fig. 2 is a block diagram of a BBU including the bypass circuit and the power converter of Fig. 1, and a control circuit for controlling the bypass circuit and the power converter according to another example embodiment.

[0012] Fig. 3 is a block diagram of a BBU including a linear regulator and a DC/DC power converter according to yet another example embodiment.

[0013] Fig. 4 is a block diagram of a BBU including a charging converter, a battery, a bypass circuit and an output converter according to another example embodiment.

[0014] Fig. 5 is a block diagram of a system including a primary power source and the BBU of Fig. 2 coupled to the primary power source according to yet another example embodiment.

[0015] Fig. 6 is a graph of an output voltage of the system of Fig. 5 versus time.

[0016] Fig. 7 is a block diagram of a system including a rectifier and a BBU controlling its bypass circuit based on an input to the rectifier according to yet another example embodiment.

[0017] Corresponding reference numerals indicate corresponding parts or features throughout the several views of the drawings.

DETAILED DESCRIPTION

[0018] Example embodiments will now be described more fully with reference to the accompanying drawings.

[0019] Example embodiments are provided so that this disclosure will be thorough, and will fully convey the scope to those who are skilled in the art. Numerous specific details are set forth such as examples of specific components, devices, and methods, to provide a thorough understanding of embodiments of the present disclosure. It will be apparent to those skilled in the art that specific details need not be employed, that example embodiments may be embodied in many different forms and that neither should be construed to limit the scope of the disclosure. In some example embodiments, well-known processes, well-known device structures, and well-known technologies are not described in detail.

[0020] The terminology used herein is for the purpose of describing particular example embodiments only and is not intended to be limiting. As used herein, the singular forms "a," "an," and "the" may be intended to include the plural forms as well, unless the context clearly indicates otherwise. The terms "comprises," "comprising," "including," and "having," are inclusive and therefore specify the presence of stated features, integers, steps, operations, elements, and/or components, but do not preclude the presence or addition of one or more other features, integers, steps, operations, elements, components, and/or groups thereof. The method steps, processes, and operations described herein are not to be construed as necessarily requiring their performance in the particular order discussed or illustrated, unless specifically identified as an order of performance. It is also to be understood that additional or alternative steps may be employed.

[0021] Although the terms first, second, third, etc. may be used herein to describe various elements, components, regions, layers and/or sections, these elements, components, regions, layers and/or sections should not be limited by these terms. These terms may be only used to distinguish one element, component, region, layer or section from another region, layer or section. Terms such as "first," "second," and other numerical terms when used herein do not imply a sequence or order unless clearly indicated by the context. Thus, a first element, component, region, layer or section discussed below could be termed a second element, component, region, layer or section without departing from the teachings of the example embodiments.

[0022] Spatially relative terms, such as "inner," "outer," "beneath," "below," "lower," "above," "upper," and the like, may be used herein for ease of description to describe one element or feature's relationship to another element(s) or feature(s) as illustrated in the figures. Spatially relative terms may be intended to encompass different orientations of the device in use or operation in addition to the orientation depicted in the figures. For example, if the device in the figures is turned over, elements described as "below" or "beneath" other elements or features would then be oriented "above" the other elements or features. Thus, the example term "below" can encompass both an orientation of above and below. The device may be otherwise oriented (rotated 90 degrees or at other orientations) and the spatially relative descriptors used herein interpreted accordingly.

[0023] A backup battery (BBU) for supplying backup power to a load according to one example embodiment of the present disclosure is illustrated in Fig. 1 and indicated generally by reference number 100. As shown in Fig. 1, the BBU 100 includes at least one battery 102, an output terminal 104 for coupling to a load (not shown), a power converter 106 having an input 108 coupled to the at least one battery 102 and an output 110 coupled to the output terminal 104, and a bypass circuit 112 having an input 114 coupled to the at least one battery 102 and an output 116 coupled to the output terminal 104. The power converter 106 is configured to regulate a voltage at the output terminal 104 after startup of the power converter 106. The bypass circuit 112 is configured to regulate the voltage at the output terminal 104 during startup of the power converter 106.

[0024] For example, when a primary power source is unable to provide a desired current and voltage to a load(s), a BBU coupled to the primary power source may provide backup power (e.g., at least temporarily) to the load(s). In such cases, a power converter within this BBU may experience a load current step from zero to a higher current (e.g., a maximum rated current) during startup. In doing so, an output voltage of this converter may experience a transient and thus the output voltage may fall below a minimum threshold voltage for keeping the load(s) active.

[0025] By employing the bypass circuit 112 to regulate the voltage at the output terminal 104 during startup of the power converter 106, the BBU 100 may be able to provide a current and regulated voltage to the load(s) at a particular setpoint (e.g., at or above a minimum threshold voltage explained above) until the output voltage of the power converter 106 is regulated at its setpoint. In such examples, the bypass circuit 112 may include circuitry allowing it to have a faster transient response than the power converter 106. As such, the BBU 100 may provide a required current and regulated voltage to the load(s) quicker than other commonly known BBUs relying on a power converter without a bypassing circuit to provide its output power. Thus, the load(s) coupled to the BBU 100 may remain active when power from a primary power source is interrupted.

[0026] In the example embodiment of Fig. 1 and as explained above, the inputs 108, 114 of the power converter 106 and the bypass circuit 112 are coupled to the battery 102 and the outputs 110, 116 of the power converter 106 and the bypass circuit 112 are coupled to the output terminal 104 of the BBU

100. As such, the bypass circuit 112 and the power converter 106 are coupled in parallel.

[0027] Although not shown in Fig. 1, the battery 102 may have an input coupled to one or more power sources (e.g., a charger) to maintain the battery 102 in a substantially charged state. Thus, and as further explained below, the battery 102 may be a rechargeable battery (e.g., a Li-Ion battery, etc.).

[0028] In some embodiments, the bypass circuit 112 and/or the power converter 106 may be controlled by a control circuit. For example, the bypass circuit 112 and/or the power converter 106 may provide a regulated voltage at a setpoint by receiving one or more control signals from the control circuit. In some embodiments, the control circuit may control when the bypass circuit 112 and/or the power converter 106 is enabled and/or disabled.

[0029] For example, Fig. 2 illustrates another BBU 200 substantially similar to the BBU 100 of Fig. 1, but including a control circuit 202 coupled to power converter 106 and the bypass circuit 112. As shown in Fig. 2, the control circuit 202 may provide one or more control signals 204 (e.g., PWM signals, etc.) to the power converter 106 and one or more control signals 206 to the bypass circuit 112. As such, the control circuit 202 may control one or more switches (e.g., one or more enable switches, power switches, etc.) of the power converter 106 and/or the bypass circuit 112.

[0030] In some embodiments, the control circuit 202 may enable (e.g., activate, etc.) the bypass circuit 112 to regulate its voltage at the output terminal 104 as explained above. For example, the bypass circuit 112 may include an

enable switch for activating the bypass circuit 112 and the control circuit 202 may provide the control signal 206 to the switch when desired. In some examples, the enable switch may be positioned exterior to the bypass circuit 112. For example, the enable switch may be positioned between the bypass circuit 112 and the output terminal 104, between the bypass circuit 112 and the battery 102, etc. In other embodiments, the control circuit 202 may provide one or more control signals 206 to one or more switches in the bypass circuit 112 to activate the circuit 112. The power converter 106 may be enabled in a similar or different manner as the bypass circuit 112.

[0031] In some examples, the bypass circuit 112 and/or the power converter 106 may be enabled after detecting a defined parameter. For example, and as shown in Fig. 2, the control circuit 202 receives one or more control signals 208 representing a voltage at the output terminal 104 of the BBU 200. This voltage may be sensed by a commonly known voltage sensor or the like. In such cases, the bypass circuit 112 and/or the power converter 106 may be enabled after the sensed voltage at the output terminal 104 meets, falls below, etc. a defined voltage threshold (e.g., a minimum threshold voltage to maintain the load(s) as explained above), etc. For example, if one or more loads coupled to the output terminal 104 require a regulated voltage of about 12V, the control circuit 202 may enable the bypass circuit 112 and/or the power converter 106 after it senses a voltage at the output terminal 104 of 11V, 11.5V, 11.75V, etc.

[0032] In other embodiments, the defined parameter may be another sensed parameter in the BBU 200 and/or a system including the BBU 200. For

example, and as further explained below, the control circuit 202 may receive a sensed input voltage of a primary power source coupled to the BBU 200, etc.

[0033] In some examples, the control circuit 202 may enable the bypass circuit 112 and the power converter 106 substantially simultaneously. This may allow the bypass circuit 112 to regulate the voltage at the output terminal 104 as soon as its able while allowing the power converter 106 to startup and overcome its possible voltage transient at the same time. As such, the bypass circuit may regulate the voltage at the output terminal 104 during startup of the power converter 106 as explained above. In other embodiments, the bypass circuit 112 may be enabled before or after the power converter 106 if desired.

[0034] In the example of Fig. 2, the control circuit 202 may disable (e.g., deactivate, etc.) the bypass circuit 112 following startup of the power converter 106. For example, the control circuit 202 may stop providing a control signal to the bypass circuit 112 once its determined the power converter 106 is able to provide current to the load(s) while being able to regulate the voltage at the output terminal 104. After which, the bypass circuit 112 may stop providing power.

[0035] In some examples, the control circuit 202 may disable the bypass circuit 112 after detecting a defined parameter. For instance, the defined parameter may include a sensed voltage and/or current, a defined period of time, a combination of a sensed voltage and/or current and a defined period of time, etc. For example, the bypass circuit 112 may have a setpoint of 11.9V and the power converter 106 may have a setpoint of 12.1V. When the bypass circuit 112

is enabled (as explained above), the bypass circuit 112 regulates the voltage at the output terminal 104 to about 11.9V. Following startup of the power converter 106 (e.g., after the converter can regulate its output), the power converter 106 regulates the voltage at the output terminal 104 to about 12.1V. Once the control circuit 202 detects (e.g., senses, etc.) the voltage at the output terminal 104 is 12.1V via, for example, the control signal 208, the control circuit 202 may disable the bypass circuit 112. Thus, in this example, the defined parameter is a voltage of 12.1 at the output terminal 104.

[0036] In other examples, the control circuit 202 may deactivate the bypass circuit 112 about ten (10) milliseconds, about fifteen (15) milliseconds, about twenty (20) milliseconds, more or less than ten (10) milliseconds, more or less than twenty (20) milliseconds, etc. after the power converter 106 is activated. Alternatively, the control circuit 202 may deactivate the bypass circuit 11 in response to a defined period of time (e.g., about ten (10) milliseconds, etc.) after the power converter 106 is activated and after sensing a particular voltage (e.g., 12.1V) at the output terminal 104.

[0037] The control circuit 202 may disable the power converter 106 after it detects an output of a primary power source is sufficient to power the load(s), the battery 102 becomes depleted (e.g., unable to provide the required voltage and current to the load, etc.), etc.

[0038] The bypass circuits disclosed herein (e.g., the bypass circuit 112 of Figs. 1 and 2) may be any suitable circuit for regulating its output and that has a desired transient response. In some examples, the bypass circuit may be a linear

regulator (sometimes referred to as a linear converter, a series converter, etc.), a switching regulator, etc. having a faster transient response than the power converter 106. Additionally, the power converters disclosed herein (e.g., the power converter 106 of Figs. 1 and 2) may include any suitable converter for regulating its output. For instance, the power converter 106 may include a switching regulator (e.g., a DC/DC converter, DC/AC inverter, etc.), etc.

[0039] For example, Fig. 3 illustrates one example BBU 300 including an input terminal 310 for receiving an input power, the battery 102 of Fig. 1 coupled to the input terminal 310 and an output terminal 304 for coupling to a load (not shown). The battery 102 may receive a charging current and voltage via the input terminal 310 when appropriate.

[0040] The BBU 300 further includes a DC/DC power converter 306 coupled between the battery 102 and the output terminal 304, a linear regulator 312 coupled between the battery 102 and the output terminal 304, and the control circuit 202 of Fig. 2 coupled to the DC/DC power converter 306 and the linear regulator 312. In the example of Fig. 3, the inputs and the outputs of the DC/DC power converter 306 and the linear regulator 312 are coupled in the parallel.

[0041] Additionally, and as explained above with reference to Figs. 1 and 2, the linear regulator 312 (e.g., a bypass circuit) regulates a voltage at the output terminal 304 during startup of the DC/DC power converter 306, and the DC/DC power converter 306 regulates the voltage at the output terminal 304 after startup of the DC/DC power converter 306. Following startup of the DC/DC

power converter 306, the linear regulator 312 may be disabled as explained above. As such, the linear regulator 312 which is typically less efficient than the DC/DC power converter 306 may provide its maximum rated output power with a regulated output voltage for a short period of time (e.g., until the DC/DC power converter 306 is able to regulate the voltage at the output terminal 304).

[0042] As shown in Fig. 3, the BBU 300 includes an enclosure 308 for housing the various components including, for example, the battery 102, the DC/DC power converter 306, the linear regulator 312, the control circuit 202, etc. of the BBU 300, and for defining the input terminal 310 and the output terminal 304. As such, the BBU 300 may be commonly referred to as a BBU module that may be replaceable, moved, etc. depending on power needs, malfunctions, etc.

[0043] Although the control circuit 202 is shown within (e.g., internal, etc.) the enclosure 308, the control circuit 202 or a portion of the control circuit 202 may be positioned outside (e.g., external, etc.) the enclosure 308. In some examples, the control circuit 202 may be coupled to a system control that communicates with various BBUs (including the BBU 300), a primary power source, etc. In other embodiments, the control circuit 202 may be a system control and positioned external the enclosure 308.

[0044] Fig. 4 illustrates another example BBU 400 substantially similar to the BBU 100 of Fig. 1 but including a common return path (e.g., a reference such as ground, etc.) for the components of the BBU. Additionally, the BBU 400 further includes an input terminal 402 similar to the input terminal 310 of Fig. 3, an output terminal 404A similar to the output terminal 304 of Fig. 3, an output

terminal 404B for coupling to the common return path, a power converter 406 coupled between the input terminal 402 and the battery 102, and an enclosure 408 similar to the enclosure 308 of Fig. 3.

[0045] In the example embodiment of Fig. 4, the power converter 406 may provide a charging current and voltage to the battery 102 when appropriate. The power converter 406 may include any suitable power conversion circuitry including, for example, an AC/DC rectifier and/or a DC/DC power converter.

[0046] In some instances, the BBUs disclosed herein may be part of a power system. For example, Fig. 5 illustrates a system 500 for supplying power to one or more load(s) 504. The system 500 includes a primary power source 502 for supplying a voltage to the load(s) 504 and the BBU 200 of Fig. 2 coupled to the primary power source 502. The BBU 200 supplies a backup voltage to the load(s) when appropriate.

[0047] As explained above, the control circuit 202 enables the bypass circuit 112 and/or the power converter 106 to regulate a voltage V_{bus} at the output (e.g., an output bus) of the system 500. For example, and with reference to the graph 600 of Fig. 6, the primary power source 502 may substantially regulate the voltage V_{bus} (e.g., at about 12V). In some instances, this voltage may begin to drop due to a malfunction, interruption, etc. related to the primary power source 502. This is shown at time T1 of the graph 600.

[0048] When the control circuit 202 detects a defined voltage drop (e.g., a defined voltage below 12V) in the voltage supplied by the primary power source 502, the control circuit 202 may enable the bypass circuit 112 and the power

converter 106 as explained above. This is shown at time T2 of the graph 600. Once the bypass circuit 112 is enabled at time T2, the voltage Vbus begins to increase back to the original regulated value (e.g., about 12V), a voltage slightly below the regulated value (e.g., about 11.9V), etc. depending on the setpoint of the bypass circuit 112.

[0049] After startup of the power converter 106, the power converter 106 is able to regulate the voltage Vbus at the original regulated voltage (e.g., about 12V), a voltage slightly higher than the bypass circuit's setpoint, a voltage slightly higher than the original regulated voltage (e.g., about 12.1V), etc. depending on the setpoint of the power converter 106. Once the control circuit 202 detects the voltage Vbus has increased to its original regulated voltage, a voltage slightly higher than the bypass circuit's set point (e.g., 12.1V), etc., the control circuit 202 may disable the bypass circuit 112. This is shown at time T3 of the graph 600. The power converter 106 may continue to regulate the voltage Vbus until the battery 102 is depleted, the primary power source 502 is providing sufficient power to the load(s) 504, etc.

[0050] Although Fig. 5 illustrates the system 500 including the BBU 200 of Fig. 2, it should be apparent that any suitable BBU including those disclosed herein may be employed without departing from the scope of the disclosure. For example, Fig. 7 illustrates another example system 700 including an AC/DC rectifier 702 for supplying a voltage to the load(s) 504 and a BBU 704 coupled to the rectifier 702. The BBU 704 is substantially similar to the BBU 200 of Fig. 2. For example, the BBU 704 includes the battery 102, the bypass circuit 112, and

the power converter 106 of Fig. 1 and, a control circuit 706 coupled to the bypass circuit 112 and the power converter 106.

[0051] As shown in Fig. 7, the control circuit 706 receives a signal 708 representing an input voltage of the rectifier 702. As such, the control circuit 706 may enable the bypass circuit 112 and/or the power converter 106 after detecting a drop in voltage at the rectifier's input. In such cases, the control circuit 706 may detect a possible interruption in power from the rectifier 702 before the output of the rectifier begins to fall below its regulated voltage (e.g., about 12V, etc.) and enable the bypass circuit 112 and/or the power converter 106 accordingly.

[0052] The control circuit 706 may disable the bypass circuit 112 and/or the power converter 106 as explained above. For example, although not shown, the control circuit 706 may disable the bypass circuit 112 after detecting a defined voltage of the output of the system 700, etc.

[0053] Although Figs. 5 and 7 illustrate a system including one BBU, it should be apparent that each system may include any suitable number of BBUs. For example, the system 500 of Fig. 5 may include three BBUs including the BBU 200 and the system 700 of Fig. 7 may include ten BBUs including the BBU 704. In such examples, each BBU may include its own control circuit that communicates with other control circuit(s). Alternatively, a system control circuit may control two or more BBUs and/or other power components of a system. Additionally, some or all of the BBUs may be coupled in parallel. For example, if

the system 500 includes three BBUs as explained above, the outputs of two of those BBUs may be coupled in parallel.

[0054] The control circuits disclosed herein may be any suitable control circuit. For example, some or all of a control circuit may be internal a particular BBU, internal a power converter of a BBU, external a BBU (e.g., a system control for one or more BBUs and/or other power components in a system), etc.

[0055] The control circuits may include an analog control circuit, a digital control circuit (e.g., a digital signal processor (DSP), a microprocessor, a microcontroller, etc.), or a hybrid control circuit (e.g., a digital control circuit and an analog control circuit). Thus, the methods disclosed herein may be performed by a digital controller. Additionally, the entire control circuit, some of the control circuit, or none of the control circuit may be an integrated circuit (IC).

[0056] The batteries disclosed herein may be any suitable battery. For example, the batteries may include rechargeable batteries such as Li-Ion batteries, NiCd batteries, NiMH batteries, etc., single use batteries, etc. Additionally, each BBU disclosed herein may include one or more batteries. For example, the BBU 100 of Fig. 1 may include a battery pack of four batteries, the BBU 200 of Fig. 2 may include five batteries, and the BBU 704 of Fig. 7 may include one battery. If two or more batteries are employed in a BBU, some or all of those batteries may be coupled in parallel and/or series.

[0057] The systems and/or the BBUs disclosed herein may be employed in any suitable application including, for example, telecommunication applications, information technology applications, etc. For example, the systems

and/or the BBUs may be employed in enclosures (e.g., data racks, server cabinets, etc.) including, for example, stationary and/or modular enclosures. Additionally, the systems and/or the BBUs may provide any suitable output power including, for example, AC power and/or DC power. In some embodiments, the systems and/or the BBUs may provide 5VDC, 12VDC, 24VDC, 48VDC, 400VDC, 120VAC, etc.

[0058] The foregoing description of the embodiments has been provided for purposes of illustration and description. It is not intended to be exhaustive or to limit the disclosure. Individual elements or features of a particular embodiment are generally not limited to that particular embodiment, but, where applicable, are interchangeable and can be used in a selected embodiment, even if not specifically shown or described. The same may also be varied in many ways. Such variations are not to be regarded as a departure from the disclosure, and all such modifications are intended to be included within the scope of the disclosure.

CLAIMS

1. A battery backup unit (BBU) for supplying backup power to a load, the BBU comprising:

at least one battery;

an output terminal for coupling to a load;

a power converter having an input coupled to the at least one battery and an output coupled to the output terminal, the power converter configured to regulate a voltage at the output terminal after startup of the power converter; and

a bypass circuit having an input coupled to the at least one battery and an output coupled to the output terminal, the bypass circuit configured to regulate the voltage at the output terminal during startup of the power converter.

2. The BBU of any other BBU claim further comprising a control circuit configured to enable the bypass circuit after detecting a defined parameter.

3. The BBU of any other BBU claim wherein the defined parameter includes a defined voltage at the output terminal.

4. The BBU of any other BBU claim wherein the control circuit is configured to enable the power converter after detecting the defined parameter.

5. The BBU of any other BBU claim wherein the control circuit is configured to enable the bypass circuit and the power converter substantially simultaneously.

6. The BBU of any other BBU claim wherein the control circuit is configured to disable the bypass circuit following startup of the power converter.

7. The BBU of any other BBU claim wherein the control circuit is configured to disable the bypass circuit after detecting a defined parameter.

8. The BBU of any other BBU claim wherein the defined parameter includes a defined voltage at the output terminal.

9. The BBU of any other BBU claim wherein the bypass circuit and the power converter are coupled in parallel.

10. The BBU of any other BBU claim wherein the power converter includes a DC/DC power converter.

11. The BBU of any other BBU claim wherein the bypass circuit includes a linear regulator.

12. A system for supplying power to one or more loads, the system comprising:

a primary power source for supplying a voltage to one or more loads;

a battery backup unit (BBU) for supplying a backup voltage to the one or more loads, the BBU coupled to the primary power source, the BBU including at least one battery, an output terminal for coupling to the one or more loads, a power converter having an input coupled to the at least one battery and an output coupled to the output terminal, and a bypass circuit having an input coupled to the at least one battery and an output coupled to the output terminal; and

a control circuit coupled to the power converter and the bypass circuit, the control circuit configured to control the power converter to regulate the backup voltage at the output terminal after startup of the power converter and to enable

the bypass circuit to regulate the backup voltage at the output terminal during startup of the power converter.

13. The system of any other system claim wherein the control circuit is configured to enable the bypass circuit after detecting a defined parameter.

14. The system of any other system claim wherein the defined parameter includes a defined voltage drop in the voltage supplied by the primary power source.

15. The system of any other system claim wherein the control circuit is configured to enable the bypass circuit and the power converter substantially simultaneously after detecting the defined parameter.

16. The system of any other system claim wherein the control circuit is configured to disable the bypass circuit following startup of the power converter.

17. The system of any other system claim wherein the control circuit is configured to disable the bypass circuit after detecting a defined parameter.

18. The system of any other system claim wherein the defined parameter includes a defined voltage at the output terminal.

19. The system of any other system claim wherein the bypass circuit and the power converter are coupled in parallel.

20. The system of any other system claim wherein the power converter includes a DC/DC power converter.

21. The system of any other system claim wherein the bypass circuit includes a linear regulator.

22. The system of any other system claim wherein the primary power source includes an AC/DC rectifier.

1/4

Fig. 1

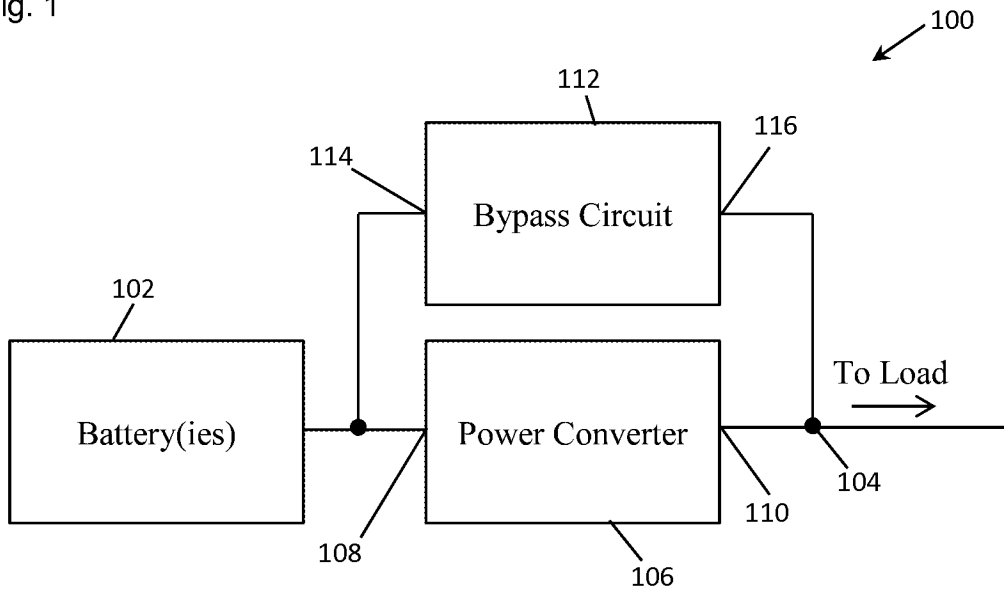

Fig. 2

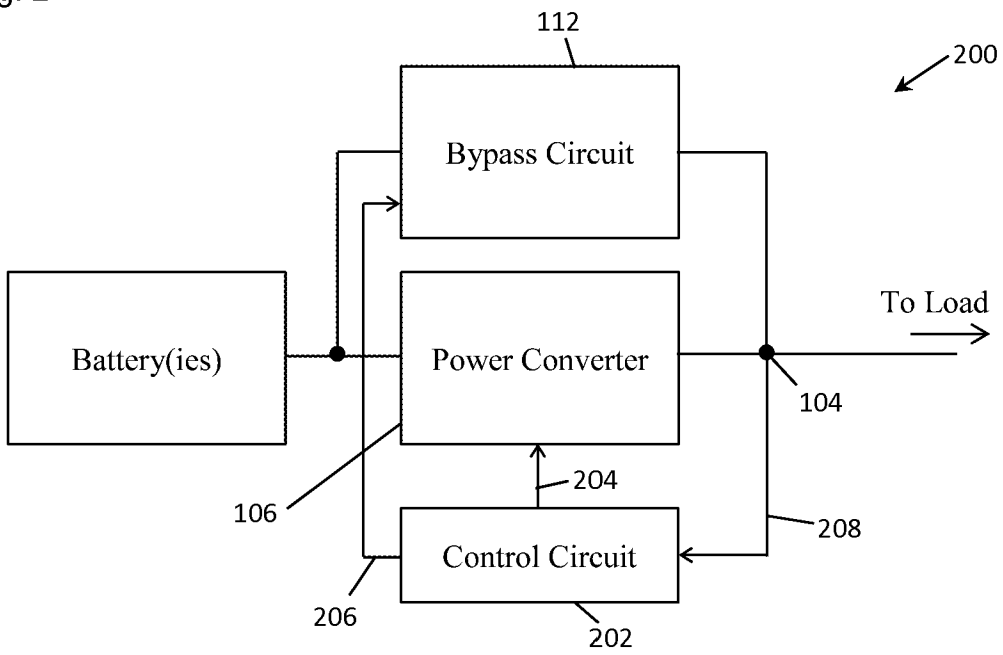

Fig. 3

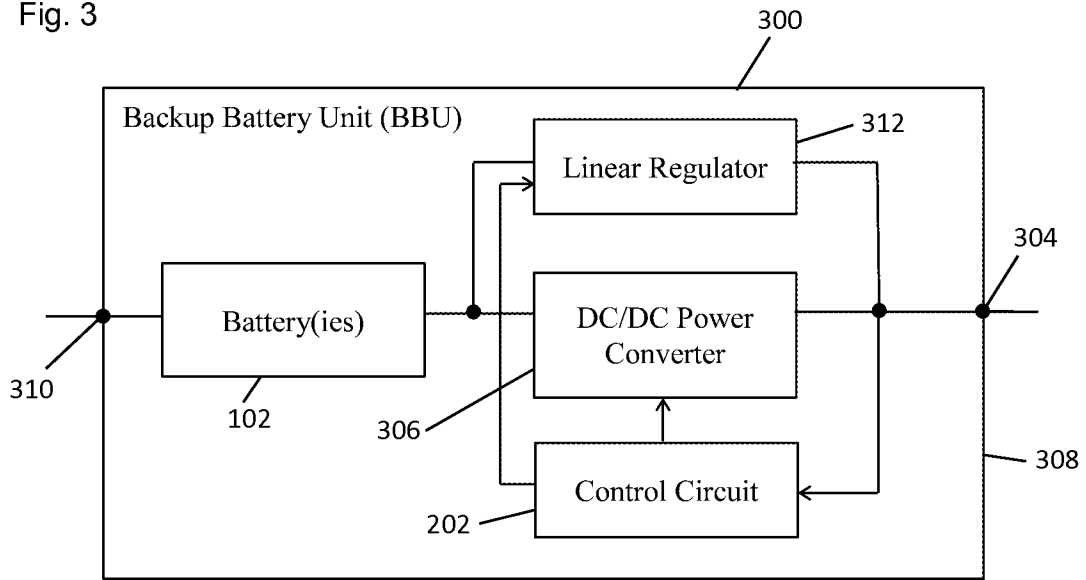

Fig. 4

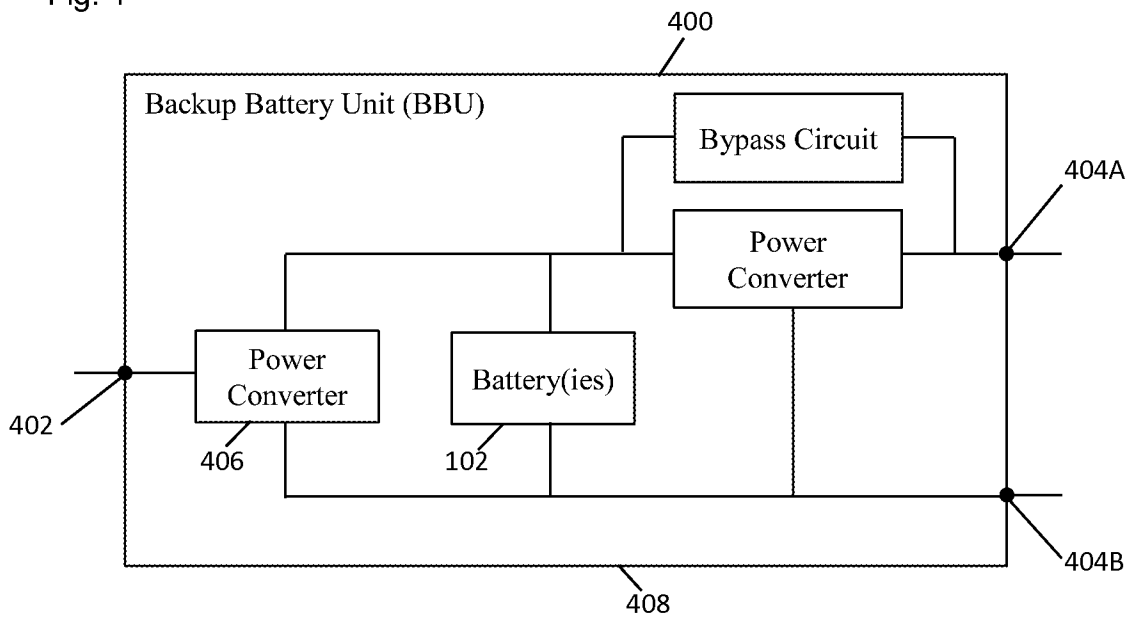

Fig. 5

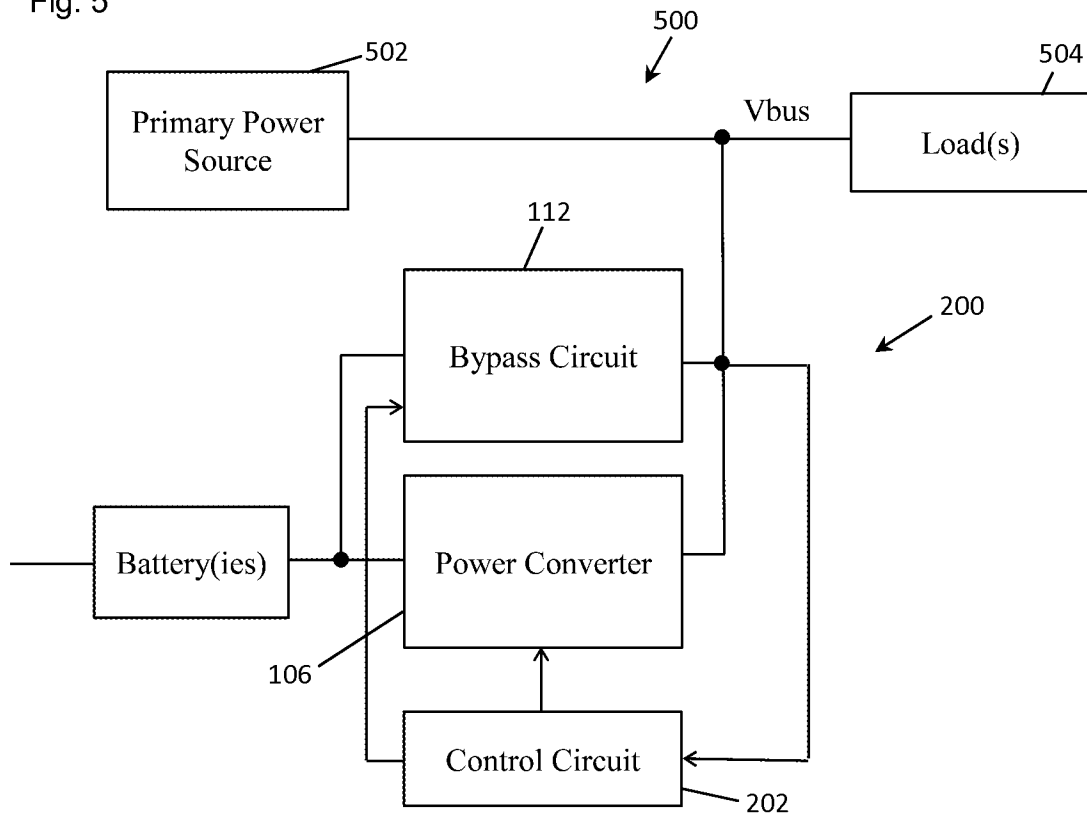

Fig. 6

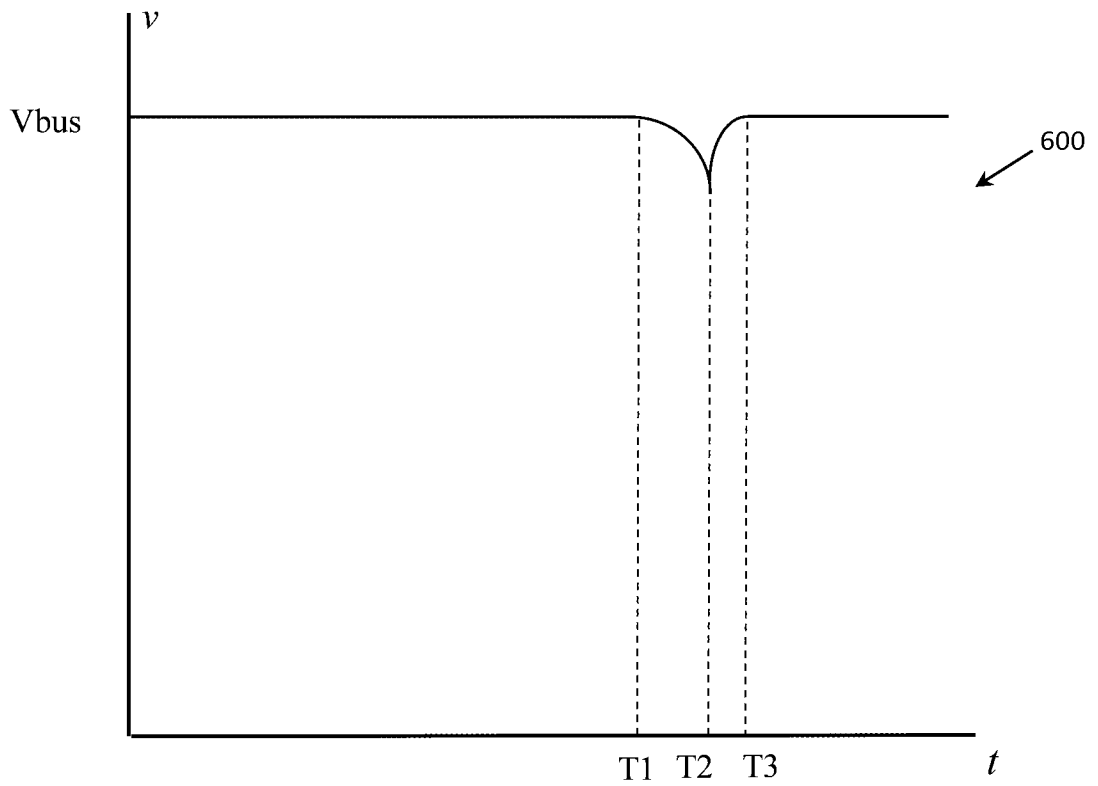
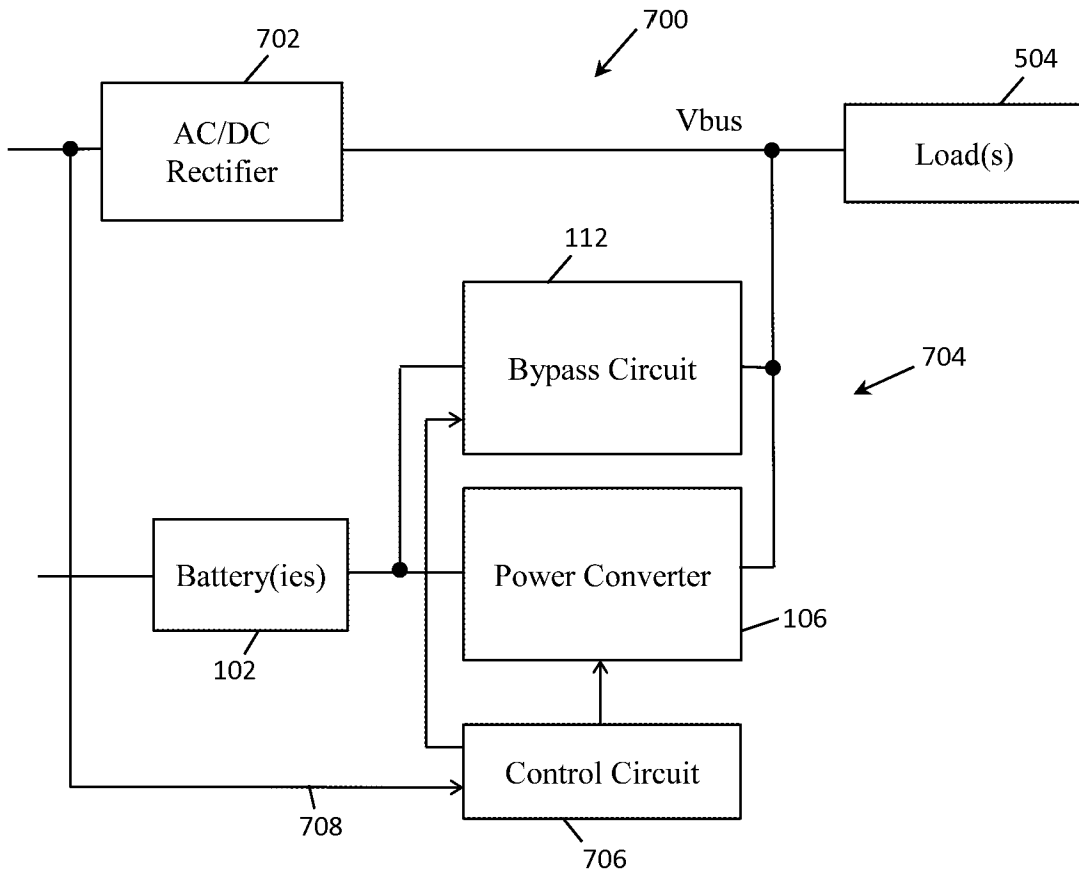

Fig. 7



A. CLASSIFICATION OF SUBJECT MATTER**H02J 9/06(2006.01)i**

According to International Patent Classification (IPC) or to both national classification and IPC

B. FIELDS SEARCHEDMinimum documentation searched (classification system followed by classification symbols)
H02J 9/06; H02M 3/335; H02J 7/04; H02J 7/00; H02J 9/00; G05F 1/56Documentation searched other than minimum documentation to the extent that such documents are included in the fields searched
Korean utility models and applications for utility models
Japanese utility models and applications for utility modelsElectronic data base consulted during the international search (name of data base and, where practicable, search terms used)
eKOMPASS(KIPO internal) & Keywords: battery backup unit, bypass, converter, regulate**C. DOCUMENTS CONSIDERED TO BE RELEVANT**

Category*	Citation of document, with indication, where appropriate, of the relevant passages	Relevant to claim No.
X	US 2013-0234686 A1 (KRISTY M. GRANT et al.) 12 September 2013 See paragraphs [0002],[0020]-[0022] and figure 2.	1, 12
A	US 2013-0082662 A1 (JEAN-YVES CARRE et al.) 04 April 2013 See abstract, paragraphs [0068]-[0070] and figure 3.	1, 12
A	US 6359794 B1 (RICHMOND ANDREW REAL) 19 March 2002 See abstract, column 4, line 30 - column 5, line 35 and figures 1,2.	1, 12
A	US 5777454 A (JOSEPH M. MCANDREWS et al.) 07 July 1998 See abstract and column 3, line 38 - column 9, line 46.	1, 12
A	US 2012-0306274 A1 (RUSSELL E. SHETLER, JR. et al.) 06 December 2012 See abstract, paragraphs [0026]-[0050] and figures 1,2.	1, 12

 Further documents are listed in the continuation of Box C. See patent family annex.

* Special categories of cited documents:

"A" document defining the general state of the art which is not considered to be of particular relevance

"E" earlier application or patent but published on or after the international filing date

"L" document which may throw doubts on priority claim(s) or which is cited to establish the publication date of another citation or other special reason (as specified)

"O" document referring to an oral disclosure, use, exhibition or other means

"P" document published prior to the international filing date but later than the priority date claimed

"T" later document published after the international filing date or priority date and not in conflict with the application but cited to understand the principle or theory underlying the invention

"X" document of particular relevance; the claimed invention cannot be considered novel or cannot be considered to involve an inventive step when the document is taken alone

"Y" document of particular relevance; the claimed invention cannot be considered to involve an inventive step when the document is combined with one or more other such documents, such combination being obvious to a person skilled in the art

"&" document member of the same patent family

Date of the actual completion of the international search

28 August 2015 (28.08.2015)

Date of mailing of the international search report

28 August 2015 (28.08.2015)

Name and mailing address of the ISA/KR



 International Application Division
 Korean Intellectual Property Office
 189 Cheongsu-ro, Seo-gu, Daejeon Metropolitan City, 35208,
 Republic of Korea

Facsimile No. +82-42-472-7140

Authorized officer

PARK, Hye Lyun

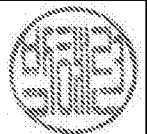
Telephone No. +82-42-481-3463



Box No. II Observations where certain claims were found unsearchable (Continuation of item 2 of first sheet)

This international search report has not been established in respect of certain claims under Article 17(2)(a) for the following reasons:

1. Claims Nos.:
because they relate to subject matter not required to be searched by this Authority, namely:

2. Claims Nos.:
because they relate to parts of the international application that do not comply with the prescribed requirements to such an extent that no meaningful international search can be carried out, specifically:

3. Claims Nos.: 2-11,13-22
because they are dependent claims and are not drafted in accordance with the second and third sentences of Rule 6.4(a).

Box No. III Observations where unity of invention is lacking (Continuation of item 3 of first sheet)

This International Searching Authority found multiple inventions in this international application, as follows:

1. As all required additional search fees were timely paid by the applicant, this international search report covers all searchable claims.
2. As all searchable claims could be searched without effort justifying an additional fees, this Authority did not invite payment of any additional fees.
3. As only some of the required additional search fees were timely paid by the applicant, this international search report covers only those claims for which fees were paid, specifically claims Nos.:

4. No required additional search fees were timely paid by the applicant. Consequently, this international search report is restricted to the invention first mentioned in the claims; it is covered by claims Nos.:

Remark on Protest

- The additional search fees were accompanied by the applicant's protest and, where applicable, the payment of a protest fee.
- The additional search fees were accompanied by the applicant's protest but the applicable protest fee was not paid within the time limit specified in the invitation.
- No protest accompanied the payment of additional search fees.

INTERNATIONAL SEARCH REPORT

Information on patent family members

International application No.

PCT/US2015/037343

Patent document cited in search report	Publication date	Patent family member(s)	Publication date
US 2013-0234686 A1	12/09/2013	EP 2550718 A2 US 8971073 B2 WO 2011-119219 A2 WO 2011-119219 A3	30/01/2013 03/03/2015 29/09/2011 08/12/2011
US 2013-0082662 A1	04/04/2013	None	
US 6359794 B1	19/03/2002	None	
US 5777454 A	07/07/1998	AU 1997-39580 B2 AU 1998-70034 B2 AU 1998-78107 B2 CA 2258733 A1 CA 2258733 C CA 2270958 A1 CA 2270958 C CA 2293348 A1 CA 2293348 C CN 1125104 C CN 1259150 A EP 0459781 A1 EP 0459781 B1 EP 0688929 A2 EP 0688929 A3 EP 0688929 B1 EP 0923663 A1 EP 0923663 B1 EP 0939997 A1 EP 0986792 A1 EP 0986905 A1 EP 0988334 A1 EP 0988334 B2 EP 1012761 A1 EP 1012761 B1 EP 1023689 A1 EP 1023689 B1 EP 1278146 A2 EP 1278146 A3 EP 1278146 B1 EP 1278166 A2 EP 1278166 A3 EP 1282058 A2 EP 1282058 A3 EP 1903517 A1 JP 2000-516313 A JP 2002-503284 A JP 4341990 B2 KR 10-0507007 B1 KR 10-2000-0068050 A	09/03/2000 30/05/2002 03/05/2001 31/12/1997 31/07/2007 14/05/1998 22/12/2009 10/12/1998 14/09/2010 22/10/2003 05/07/2000 04/12/1991 17/04/1996 27/12/1995 17/12/1997 13/10/2004 26/02/2003 13/08/2008 07/02/2001 22/03/2000 22/03/2000 29/03/2000 27/07/2005 28/06/2000 09/04/2003 02/08/2000 19/12/2007 22/01/2003 02/11/2005 23/12/2009 22/01/2003 20/04/2005 05/02/2003 02/11/2005 26/03/2008 05/12/2000 29/01/2002 14/10/2009 09/08/2005 25/11/2000

INTERNATIONAL SEARCH REPORT

Information on patent family members

International application No.

PCT/US2015/037343

Patent document cited in search report	Publication date	Patent family member(s)	Publication date
		TW I408551 B	11/10/2000
		US 2002-0042736 A1	11/04/2002
		US 2002-0145038 A1	10/10/2002
		US 2002-0165778 A1	07/11/2002
		US 2002-0178091 A1	28/11/2002
		US 2002-0194075 A1	19/12/2002
		US 2003-0040969 A1	27/02/2003
		US 5517187 A	14/05/1996
		US 5686904 A	11/11/1997
		US 5773954 A	30/06/1998
		US 5821512 A	13/10/1998
		US 5821513 A	13/10/1998
		US 5886503 A	23/03/1999
		US 5905536 A	18/05/1999
		US 5959059 A	28/09/1999
		US 6119935 A	19/09/2000
		US 6129276 A	10/10/2000
		US 6166650 A	26/12/2000
		US 6168079 B1	02/01/2001
		US 6175312 B1	16/01/2001
		US 6314406 B1	06/11/2001
		US 6595417 B2	22/07/2003
		WO 97-45911 A1	04/12/1997
		WO 97-50055 A1	31/12/1997
		WO 98-20440 A1	14/05/1998
		WO 98-55717 A1	10/12/1998
		WO 98-55954 A1	10/12/1998
		WO 98-56175 A1	10/12/1998
		WO 98-56845 A1	17/12/1998
		WO 98-58271 A1	23/12/1998
US 2012-0306274 A1	06/12/2012	CN 103390929 A	13/11/2013
		US 9000613 B2	07/04/2015