

(19) World Intellectual Property Organization  
International Bureau



(43) International Publication Date  
9 December 2010 (09.12.2010)

(10) International Publication Number  
**WO 2010/141894 A1**

- (51) **International Patent Classification:**  
A61M 25/01 (2006.01)
- (21) **International Application Number:**  
PCT/US2010/037508
- (22) **International Filing Date:**  
4 June 2010 (04.06.2010)
- (25) **Filing Language:** English
- (26) **Publication Language:** English
- (30) **Priority Data:**  
12/479,521 5 June 2009 (05.06.2009) US
- (71) **Applicant (for all designated States except US):** ENTEL-  
LUS MEDICAL, INC. [US/US]; 6705 Wedgwood Ct.  
North, Maple Grove, Minnesota 55311 (US).
- (72) **Inventors; and**
- (73) **Inventors/Applicants (for US only):** DRONTLE, John  
R. [US/US]; 10560 97th Street, NE, Monticello, Min-  
nesota 55362 (US). HANSON, Anthony J. [US/US]; 433  
Amberg Lane, Chaska, Minnesota 55318 (US).
- (74) **Agent:** DAVIDSON, Michael S.; Vista IP Law Group,  
LLP, 2040 Main Street, Suite 710, Irvine, California  
92614 (US).

- (81) **Designated States (unless otherwise indicated, for every kind of national protection available):** AE, AG, AL, AM, AO, AT, AU, AZ, BA, BB, BG, BH, BR, BW, BY, BZ, CA, CH, CL, CN, CO, CR, CU, CZ, DE, DK, DM, DO, DZ, EC, EE, EG, ES, FI, GB, GD, GE, GH, GM, GT, HN, HR, HU, ID, IL, IN, IS, JP, KE, KG, KM, KN, KP, KR, KZ, LA, LC, LK, LR, LS, LT, LU, LY, MA, MD, ME, MG, MK, MN, MW, MX, MY, MZ, NA, NG, NI, NO, NZ, OM, PE, PG, PH, PL, PT, RO, RS, RU, SC, SD, SE, SG, SK, SL, SM, ST, SV, SY, TH, TJ, TM, TN, TR, TT, TZ, UA, UG, US, UZ, VC, VN, ZA, ZM, ZW.
- (84) **Designated States (unless otherwise indicated, for every kind of regional protection available):** ARIPO (BW, GH, GM, KE, LR, LS, MW, MZ, NA, SD, SL, SZ, TZ, UG, ZM, ZW), Eurasian (AM, AZ, BY, KG, KZ, MD, RU, TJ, TM), European (AL, AT, BE, BG, CH, CY, CZ, DE, DK, EE, ES, FI, FR, GB, GR, HR, HU, IE, IS, IT, LT, LU, LV, MC, MK, MT, NL, NO, PL, PT, RO, SE, SI, SK, SM, TR), OAPI (BF, BJ, CF, CG, CI, CM, GA, GN, GQ, GW, ML, MR, NE, SN, TD, TG).

**Published:**

— with international search report (Art. 21(3))

(54) **Title:** FRONTAL SINUS DILATION CATHETER

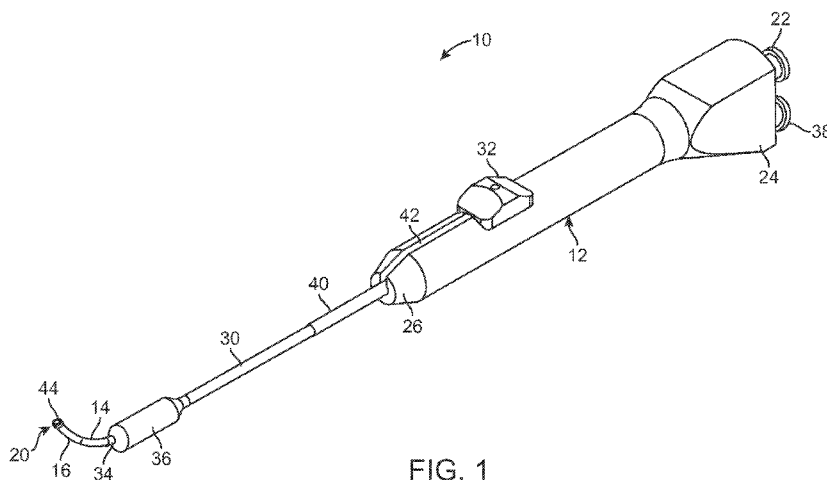

FIG. 1

(57) **Abstract:** A balloon dilation catheter includes a substantially rigid inner guide member and a movable shaft coupled to a balloon that is slidably mounted on the substantially rigid inner guide member. To treat a sinus cavity of a subject using the balloon dilation the substantially rigid inner guide member is advanced into a drainage pathway of the sinus (e.g., frontal recess) of the subject via a nasal passageway. The shaft and balloon are advanced in a distal direction over the substantially rigid inner guide member to place the balloon in the drainage pathway. The balloon is inflated to expand or otherwise remodel the drainage pathway.

WO 2010/141894 A1

## FRONTAL SINUS DILATION CATHETER

### **Field of the Invention**

The field of the invention generally relates to balloon inflation devices and methods. More particularly, the field of the invention relates to balloon dilation devices and methods for the treatment of sinusitis.

### **Background of the Invention**

Sinusitis is a condition affecting over 35 million Americans, and similarly large populations in the rest of the developed world. Sinusitis occurs when one or more of the four paired sinus cavities (i.e., maxillary, ethmoid, frontal, sphenoid) becomes obstructed, or otherwise has compromised drainage. Normally the sinus cavities, each of which are lined by mucosa, produce mucous which is then moved by beating cilia from the sinus cavity out to the nasal cavity and down the throat. The combined sinuses produce approximately one liter of mucous daily, so the effective transport of this mucous is important to sinus health.

Each sinus cavity has a drainage pathway or outflow tract opening into the nasal passage. This drainage passageway can include an ostium, as well as a "transition space" in the region of the ostia, such as the "frontal recess," in the case of the frontal sinus, or an "ethmoidal infundibulum," in the case of the maxillary sinus. When the mucosa of one or more of the ostia or regions near the ostia become inflamed, the egress of mucous is interrupted, setting the stage for an infection and/or inflammation of the sinus cavity, i.e., sinusitis. Though many instances of sinusitis may be treatable with appropriate medicates, in some cases sinusitis persists for months or more, a condition called chronic sinusitis, and may not respond to medical therapy. Some patients are also prone to multiple episodes of sinusitis in a given period of time, a condition called recurrent sinusitis.

Balloon dilation has been applied to treat constricted sinus passageways for the treatment of sinusitis. These balloon dilation devices typically involve the use of an inflatable balloon located at the distal end of a catheter such as a balloon catheter. Generally, the inflatable balloon is inserted into the constricted sinus passageway in a deflated state. The balloon is then expanded to open or reduce the degree of constriction in the sinus passageway being treated to facilitate better sinus

drainage and ventilation. At the same time most, if not all, of the functional mucosal tissue lining of the sinuses and their drainage passageways are preserved.

Exemplary devices and methods particularly suited for the dilation of anatomic structures associated with the maxillary and anterior ethmoid sinuses are disclosed, for example, in U.S. Patent No. 7,520,876 and U.S. Patent Application Publication No. 2008-0172033. Other systems have been described for the treatment of various other sinuses including the frontal sinus. For example, U.S. Patent Application Publication No. 2008-0097295 discloses a frontal sinus guide catheter (FIG. 6B) and method of treating the frontal sinuses (e.g., FIGS. 8B-8C). U.S. Patent Application Publication No. 2008-0125626 discloses another guide device (e.g., FIGS. 10C and 10C') for transnasal access to the frontal sinuses for treatment.

### **Summary of the Invention**

In a first embodiment of the invention, a balloon dilation catheter includes a substantially rigid inner guide member and a movable shaft coupled to a balloon that is slidably mounted on the substantially rigid inner guide member. To treat a drainage pathway of a sinus cavity (e.g., frontal sinus cavity) of a subject using the balloon dilation catheter, the substantially rigid inner guide member is advanced into a drainage pathway of the subject via a nasal passageway. The shaft and balloon are then advanced in a distal direction over the substantially rigid inner guide member to place the balloon in the drainage pathway. This enables the balloon to track over the inner guide member. The balloon is inflated to expand or otherwise remodel the drainage pathway. Where the sinus cavity is the frontal sinus cavity the drainage pathway is the frontal recess.

In another aspect of the invention, a device for dilating the outflow tract of a sinus cavity includes a substantially rigid inner guide member having a proximal end and a distal end and a shaft coupled to a balloon, the shaft having a first lumen along at least a portion thereof containing the substantially rigid inner guide member, the shaft having a second lumen operatively coupled to the interior of the balloon. A handle is disposed along a proximal portion of the substantially rigid inner guide member, the handle including a moveable knob operatively coupled to the shaft, wherein distal advancement of the knob advances the shaft and balloon over the substantially rigid inner guide in a distal direction.

### **Brief Description of the Drawings**

FIG. 1 illustrates a perspective view of a balloon dilation catheter according to one embodiment.

FIG. 2A illustrates a side view of a balloon dilation catheter of FIG. 1. The advancer knob is illustrated in the retracted, proximal position.

FIG. 2B illustrates a cross-sectional view of the balloon dilation catheter of FIG. 2A.

FIG. 3A illustrates a side view of a balloon dilation catheter of FIG. 1. The advancer knob is illustrated in the advanced, distal position.

FIG. 3B illustrates a cross-sectional view of the balloon dilation catheter of FIG. 3A.

FIG. 4 is a cross-sectional view of the handle portion (dashed line portion) of FIG. 3B.

FIG. 5A is a cross-sectional view of the balloon dilation catheter taken along the line A-A' of FIG. 2B.

FIG. 5B is a cross-sectional view of the balloon dilation catheter taken along the line B-B' of FIG. 4.

FIG. 6A is a side view of an inner guide member according to one embodiment.

FIG. 6B is a side view of an inner guide member according to another embodiment.

FIG. 6C is a side view of an inner guide member according to another embodiment.

FIG. 7 illustrates a perspective view of a balloon dilation catheter according to another embodiment.

FIG. 8 illustrates a cross-sectional view of the frontal sinus of a subject with the inner guide member of the balloon dilation catheter being advanced into the subject's frontal recess.

FIG. 9 illustrates a cross-sectional view of the frontal sinus of a subject with the inner guide member of the balloon dilation catheter being positioned in the subject's frontal recess. A guide wire is shown advanced through the catheter and into the subject's frontal sinus cavity.

FIG. 10 illustrates a cross-sectional view of the frontal sinus of a subject with the balloon (in a deflated state) and shaft being advanced into the subject's frontal recess.

FIG. 11 illustrates a cross-sectional view of the frontal sinus of a subject with the balloon of FIG. 10 in an inflated state to thereby widen and remodel the frontal recess.

FIG. 12 illustrates a cross-sectional view of the frontal sinus of a subject after the frontal sinus has been widened and the balloon inflation catheter withdrawn.

### **Detailed Description of the Illustrated Embodiments**

FIG. 1 illustrates one embodiment of a balloon dilation catheter 10 that is particularly suited for treatment of the outflow tract (frontal sinus ostium and frontal recess) of the frontal sinus of a subject. The balloon dilation catheter 10 includes a handle 12 that is configured to be gripped or otherwise manipulated by the operator. An elongate-shaped inner guide member 14 extends longitudinally from the handle 12 in a distal direction. The inner guide member 14 is formed of a suitably rigid material such as stainless steel hypotube. The inner guide member 14 projects or otherwise extends distally from the handle 12 for a pre-determined distance. The inner guide member 14 may be pre-shaped to have a curved distal portion 16 as is illustrated in FIGS. 1, 2A, 2B, 3A, 3B, 6A, 6B, 7, 8, and 9. For example, the nature and degree of the curved distal portion 16 may be configured to match with the frontal sinus outflow tract or frontal recess.

Alternatively, the inner guide member 14 may have some degree of malleability such that the user may bend or impart some desired shape or configuration to the distal end of the inner guide member 14. As explained herein in more detail, the inner guide member 14 may include an optional lumen 18 (best illustrated in FIG. 5A) that extends the length of the inner guide member 14. In particular, the inner guide member 14 and the contained lumen 18 may extend from a distal end 20 to a proximal end 21 (best seen in FIGS. 2B and 3B) that interfaces with a sealed arrangement with a port 22 disposed at a proximal end 24 of the handle 12. The port 22 may be configured with a conventional interface such as a Luer connector. The port 22 may be used as an aspiration port or a delivery port for fluids and/or medicaments, or for introduction of a guide wire.

Still referring to FIG. 1, a shaft 30 is mounted about the periphery of the inner guide member 14. In particular, the shaft 30 is dimensioned to slide over the inner guide member 14 in response to actuation of an advancer knob 32 located on the handle 12. The advancer knob 32 is moveable along a slot 42 contained in a surface of the handle 12. A distal end 34 of the shaft 30 includes a balloon 36 that is configured to be selectively inflated or deflated as explained herein. During use, the inner guide member 14 is manipulated and advanced across or into the anatomical space of interest. The shaft 30 as well as the attached balloon 36 is illustrated in a retracted state in FIG. 1. While FIG. 1 illustrates the balloon 36 in an inflated state for better illustration, the balloon 36 is typically in a deflated state when the shaft 30 is in the proximal position as illustrated in FIGS. 2A and 2B. After the inner guide member 14 is properly positioned, the user actuates the advancer knob 32 by sliding the same in the distal direction which, in turn, advances the shaft 30 and balloon 36 in a distal direction over the pre-placed inner guide member 14. Once the balloon 36 is properly placed, the balloon 36 is inflated. Inflation of the balloon 36 is accomplished using an inflation device (not shown) that is coupled to a port 38 located at the proximal end 24 of the handle 12. One exemplary inflation device that may be used in connection with the balloon dilation catheter 10 is described in U.S. Patent Application No. 12/372,691, which is incorporated by reference as if set forth fully herein. Of course, other inflation devices may also be used. An inflation lumen 48 contained within the shaft 30 (described in more detail below), fluidically couples the port 38 to an interior portion of the balloon 36.

Still referring to FIG. 1, an optional support member 40 in the form of a tube may be located about the external periphery of a portion of the shaft 30 to impart further stiffness to the balloon dilation catheter 10. The particular length of the support member 40 may vary depending on the application and may extend along some or all of the shaft 30. The support member 40 may be made of a metallic material such as stainless steel hypotube that is secured to the shaft 30. The support member 40 may be welded or bonded along a length of the shaft 30. Generally, the support member 40 does not cover the helical portion (described in detail below) of the shaft 30 that is contained within the handle 12.

FIGS. 2A and 2B illustrate, respectively, side and cross-sectional views of the balloon dilation catheter 10 with the advancer knob 32 and thus balloon 36 in the proximal position. In actual use, as explained herein, the balloon 36 is typically in a

deflated state when the advancer knob 32 is the proximal position as illustrated in FIGS. 2A and 2B. As best seen in FIG. 1, the advancer knob 32 is slidably disposed along a length of the handle 12 inside a slot 42. The advancer knob 32 is thus able to slide back and forth in the distal/proximal direction along the length of the slot 42. The slot 42 may incorporate a stop or the like (not shown) to prevent the balloon 36 from being advanced too far along the length of the inner guide member 14. The length of the slot 42 may be varied in different devices to adjust the length at which the balloon 36 may be advanced. Generally, the slot 42 has a length within the range of about 1 inch to about 2 inches although other dimensions may fall within the scope of the invention.

As seen in FIG. 2B, the advancer knob 32 may be directly coupled to the support member 40 that is mounted on the shaft 30. Alternatively, the advancer knob 32 may be coupled directly to the shaft 30. The advancer knob 32 may be configured or otherwise shaped to enable a finger of the user (e.g., index finger or thumb) to easily advance or retract the knob 32 along the slot 42 contained in the handle 12.

FIGS. 3A and 3B illustrate, respectively, side and cross-sectional views of the balloon dilation catheter 10 with the advancer knob 32 and thus balloon 36 in the distal position. Thus, unlike the configurations of FIGS. 2A and 2B, the advancer knob 32 is located at or near the distal end 26 of the handle 12. Advancement of the advancer knob 32 also slides the shaft 30 and attached balloon 36 in a distal direction (arrow A in FIG. 3A) along the inner guide member 14. The balloon 36 thus is positioned at or adjacent to the distal end 20 of the inner guide member 14. The balloon dilation catheter 10 may be designed such that the advancer knob 32 may be positioned at either the proximal or distal extremes as illustrated in FIGS. 2A, 2B, 3A, 3B. Alternatively, the advancer knob 32 may be positioned somewhere in between the two extremes. For example, the optimal position of the balloon 36 may be accomplished by sliding the advancer knob 32 some fraction (e.g.,  $\frac{3}{4}$ ) of the full distance of the slot 42.

Referring to FIGS. 2B and 3B, the inner guide member 14 of the balloon dilation catheter 10 extends from a distal end 20 to a proximal end 21 that terminates in a sealed interface with a port 22 disposed at a proximal end 24 of the handle 12. The inner guide member 14 optionally includes a lumen 18 disposed therein that may be used to provide aspiration functionality via an aspiration device (not shown)

coupled to port 22. Aspiration functionality permits the removal of blood and other secretions. This makes it easier to visualize the placement of the balloon dilation catheter 10. The inner guide member 14 is advantageously rigid to enable the balloon dilation catheter 10 to be positioned without the need of a separate guiding catheter or guide wire in most, if not all, instances.

The inner guide member 14 may have a length of about 7 inches to about 11 inches from the distal end 20 to the proximal end 21 when loaded into the handle 12, although other dimensions may be used. The inner guide member 14 may be formed from stainless steel hypotube having an inner diameter in the range of about 0.020 inch to about 0.050 inch, and more preferably between about 0.036 inch and 0.040 inch, with a wall thickness within the range of about 0.005 inch to about 0.020 inch, and more preferably between about 0.008 inch to about 0.012 inch. The curved distal portion 16 of the inner guide member 14 may be formed right to the distal end 20 and may have a radius of curvature of about 0.25 inch to about 1.5 inch, and more preferably about 0.75 to about 1.25 inch.

The length of the inner guide member 14 that projects distally from the distal-most portion of the balloon 36 is about 0.5 inch to about 2.0 inch, and more preferably, about 0.8 inch to about 1.2 inch when the balloon 36 is in the fully retracted state (e.g., illustrated in FIGS. 2A and 2B). As seen in FIGS. 1, 2A, 2B, 3A, 3B, 6A-6C, 7-11, the distal end 20 of the inner guide member 14 may incorporate an optional bulbous tip 44 in order to make the distal end 20 more atraumatic. The bulbous tip 44 further serves to limit forward movement of the balloon 36 and attached shaft 30 when they are advanced distally. The outer diameter of the tip 44 is preferably between about 1 mm and about 3 mm.

The balloon 36 is mounted on the shaft 30 so as to form a fluidic seal between the two components. The balloon 36 may be bonded to the shaft using a weld, adhesive, or the like. Alternately, the balloon 36 may be secured to the shaft using a mechanical connection. Generally, any technique known to those skilled in the art may be used to secure to the balloon 36 to the shaft 30. Given that the balloon 36 is secured directly to the shaft 30, both structures are slidably mounted over the inner guide member 14. The balloon 36 generally takes on a cylindrical-shape when inflated. While not limited to specific dimensions, the inflated balloon 36 has a diameter within the range of about 3 mm to about 9 mm, and more preferably a diameter within the range of about 5 to about 7 mm when inflated. The length of



the balloon 36 may generally fall within the range of about 10 mm to 25 mm although other lengths may be used. Both the shaft 30 and the balloon 36 are preferably formed of high strength but flexible polymeric materials such as polyamides (e.g., Nylon), PEBAX or the like. The balloon 36 may be "blow molded" to a relatively thin wall thickness, and capable of holding relatively high pressures from about 6 atmospheres to about 20 atmospheres of inflation pressure. The balloon 36 is inflated using a fluid which is typically a liquid such as water or saline.

Referring now to FIG. 4, a magnified, cross-sectional view of a portion of the handle 12 is illustrated. At the proximal end 24 of the handle 12 are located ports 22, 38. The port 22 may be configured with a conventional interface such as a Luer connector or any other connector known to those skilled in the art. The port 22 may be integrally formed with the handle 12 or, alternatively, the port 22 may be a separate structure that is secured to the handle 12 during assembly. As seen in FIG. 4, the proximal end 21 of the inner guide member 14 forms a sealing arrangement with the port 22. As explained herein, the port 22 may be used as an aspiration port or a delivery port for fluids and/or medicaments.

FIG. 4 also illustrates port 38 which may be constructed in the same or similar manner as port 22 as described above. The port 38 is fluidically coupled to the inflation lumen 48 in the shaft 30. In this regard, inflation fluid from an inflation device (not shown) is able to pass through the port 38 and into the inflation lumen 48 of the shaft 30. The port 38 may be configured with a conventional interface such as a Luer connector. The fluid then is able to travel along the length of the shaft 30 via the lumen 48 where the fluid enters the interior of the balloon 36. The inflation fluid is thus able to inflate the balloon 36 upon actuation of the inflation device.

As best seen in FIG. 4, a portion of the handle 12 includes a recessed region 50 that receives both the inner guide member 14 and the shaft 30. In the recessed region 50 of the handle 12, the shaft 30 is helically wrapped around the outer periphery of the inner guide member 14 forming a helical portion 52. The helical portion 52 facilitates the distal advancement and proximal retraction of the shaft 30 and attached balloon 36 along the inner guide member 14 yet still maintains fluid communication with the port 38. The helical portion 52 of the shaft 30, which is located proximal to the advancer knob 32 is in the shape of a helix that wraps around the inner guide member 14 and is configured to elongate and contract upon movement of the advancer knob 32. FIG. 4 illustrates the state of the helical portion

52 after the advancer knob 32 has been advanced distally. Thus, in the extended state, the length of the helical portion 52 traverses much if not all of the recessed region 50. Contrast this with FIG. 2B which illustrates the helical portion 52 compressed to the proximal portion of the recessed region 50 because the advancer knob 32 is in the proximal position. Thus, the helical portion 52 is thus able to expand or compress much in the way that a spring does in response to a tensile or compressive load. One or both of the inner guide member 14 and the helical portion 52 of the shaft 30 may be optionally coated or lined with a lubricious coating to prevent the contact surfaces from any unwanted frictional binding or the like.

The helical portion 52 of the shaft 30 may be formed by "skiving" away a portion of the shaft 30. FIG. 5A illustrates a cross-sectional view of the shaft 30, inner support guide 14, and support member 40 along the line A-A' of FIG. 2B. As seen in FIG. 2B, this area is distal to where the helical portion 52 of the shaft 30 is located. Referring now to FIG. 5A, the shaft 30 includes a rider lumen 54 that is dimensioned to have a diameter that is slightly larger than the outer diameter of the inner support guide 14. The rider lumen 54 thus enables the shaft 30 to advance and retract over the inner support guide 14 in a close-fit arrangement. The outer diameter of the shaft 30 may generally fall within the range of about .050 inch to about .110 inch or within the range of about .070 inch to about .100 inch. One or both of the exterior surface of the inner guide member 14 and the interior surface of the rider lumen 54 may be optionally coated with a lubricious coating to reduce frictional contact forces. FIG. 5B illustrates a cross-sectional view of the inner support guide 14 and the helical portion 52 of the shaft 30 taken along the line B-B' of FIG. 4. As seen in FIG. 5B, a portion of the shaft 30 that includes the rider lumen 54 is skived away. The result is that a single lumen (inflation lumen 48) remains in the shaft 30 that is helically wrapped about the inner support guide 14.

FIGS. 6A-6C illustrate various embodiments of an inner guide member 14. The inner guide member 14 may have a variety of shapes and configurations depending on the particular application or patient. The different shapes of the inner guide member 14 may be factory-formed in a particular shape and offered as a different model as fully assembled or, alternatively, the inner guide member 14 may be replaceable or modular elements that could slide inside the rider lumen 54 and inserted into the port 22 in a press-fit type sealing arrangement. In yet another alternative, the shapes could represent desirable shapes that a malleable inner

guide member 14 could be formed into by the user to better fit a particular application or subject's anatomy.

FIG. 6A illustrates an inner guide member 14 that includes a curved distal portion 16 that terminates in a straight segment 46. In the embodiment of FIG. 6A, the curve in the curved distal portion 16 is pronounced and turns back on itself in the shape of a "U" in which the distal end 20 turns back in retrograde fashion. This embodiment may be useful to treat hard to reach ostia or other structures, e.g., the maxillary ostium or the infundibulum via a transnasal route, if the nasal anatomy will allow for a trans-nasal approach. While FIG. 6A illustrates a "U" shaped curve, other degrees of curvature are contemplated. FIG. 6B illustrates an inner guide member 14 according to another embodiment. In this embodiment, the curved distal portion 16 also terminates in a straight segment 46 although the radius of curvature is less pronounced. In this embodiment, the straight segment 46 may have a length within the range of about 8 mm to about 10 mm although other lengths may be used. It is believed that this embodiment is particularly suited for most frontal recess anatomy. FIG. 6C illustrates an embodiment in which the inner guide member 14 is substantially straight. This later embodiment may be particularly suited for treating the sphenoids of the subject, or straightforward frontal recess anatomy.

FIG. 7 illustrates a balloon dilation catheter 10 according to another embodiment. In this embodiment, a tracking element 60 is located on the handle 12 of the balloon dilation catheter 10. The tracking element 60 may include an antenna, transmitter, optical reflectors, or the like that communicates a wireless signal that is then received and processed to determine the orientation and/or positioning of the balloon dilation catheter 10. In certain embodiments, more than one tracking element 60 may be disposed on the balloon dilation catheter 10. Data regarding the orientation and/or positioning of the balloon dilation catheter 10 may then be processed and displayed on the display for viewing by the physician. For example, image guided surgery is becoming increasingly commonplace, permitting physicians to review real time actual or virtual images of a particular device within a subject during a surgical procedure.

For example, U.S. Patent Nos. 5,391,199 and 5,443,489, which are incorporated by reference, describe a system wherein coordinates of an intrabody probe are determined using one or more field sensors such as, Hall effect devices, coils, or antennas that are carried on the probe. U.S. Patent Application Publication

No. 2002-0065455, which is also incorporated by reference, describes a system that is capable of generating a six-dimensional position and orientation representation of the tip of a catheter using a combination of sensor and radiation coils. U.S. Patent Application Publication No. 2008-0269596, which is also incorporated by reference, describes yet another monitoring system that has particular applications in orthopedic procedures. Commercial systems such as the LANDMARX Element (Medtronic Xomed Products, Inc., Jacksonville, FL) are available for use in conjunction with ENT procedures.

In the embodiment of FIG. 7, the tracking element 60 permits accurate tracking of the distal end 20 of the balloon dilation catheter 10 such that an image of distal portion of the balloon dilation catheter 10 may be superimposed on a patient's anatomical imagery. For example, a previously conducted computed tomography (CT) scan of the patient may be used to generate a visual image of the patient's anatomical regions of interest. Based on the location of the tracking element 60, an image guided surgery (IGS) system can then superimpose an image of the balloon dilation catheter 10 onto the image to better enable the physician to manipulate and orient the balloon dilation catheter 10.

Other commercial systems may also be used in connection with the balloon dilation catheter 10 illustrated in FIG. 7. For example, the INSTATRAK 3500 Plus - ENT from GE Healthcare, Chalfont St. Giles, United Kingdom may be integrated and/or used with the balloon dilation catheter 10. The use of CT guidance to position the balloon dilation catheter 10 is preferred because the device may be positioned by the operator with just a single hand, while viewing the CT image interface (e.g., display) at the same time the handle 12 is manipulated. Optionally, the balloon dilation catheter 10 may be initially positioned using an endoscope or other visualization tool. For instance, a conventional "Hopkins rod" endoscope (not shown) may be manipulated alongside the balloon dilation catheter 10 to aid in placement.

FIGS. 8-12 illustrate various cross-sectional views (sagittal plane) of the frontal sinus of a subject undergoing treatment with a balloon dilation catheter 10. The cross-sectional views illustrate the nasal passageway 100, the frontal recess 102, and the frontal sinus cavity 104. Referring to FIG. 8, the balloon dilation catheter 10 is inserted into the nasal passageway 100 with the advancer knob 32 in the retracted position (e.g., as illustrated in FIG. 1, 2A, 2B) such that the shaft 30 and

balloon 36 are also retracted proximally. In addition, the balloon 36 is in a deflated state as seen in FIG. 8. The curved portion 16 of the inner guide member 14 is then positioned within the frontal recess 102 of the subject as seen in FIG. 8. This positioning of the inner guide member 14 may be accomplished under endoscopic visualization using a conventional endoscope such as a Hopkins rod-type endoscope that is positioned alongside the balloon dilation catheter 10. Alternatively, the inner guide member 14 may be positioned using IGS techniques that track the position of the balloon dilation catheter 10 using one or more tracking elements 60 as illustrated, for instance, in the embodiment of FIG. 7. For instance, the inner guide member 14 may be advanced under guidance from CT imaging.

Referring now to FIG. 9, confirmation of accurate positioning of the inner guide member 14 within the frontal recess 102 may be accomplished by placement of a fluoroscopically visible guide wire 64 through the lumen 18 of the inner guide member 14. The guide wire 64 may be inserted into the lumen 18 via the port 22. Under fluoroscopic visualization, the guide wire 64 can be seen to advance into the frontal sinus cavity 104 once the inner guide member 14 is positioned properly within the frontal recess 102. If the guide wire 64 does not advance into the frontal sinus cavity 104, the balloon dilation catheter 10 is re-positioned and confirmation is subsequently attempted. As an alternative to a fluoroscopically visible guide wire 64, the guide wire 64 could be a light emitting guide wire such as that disclosed in U.S. Patent Application Publication No. 2007-0249896, which is incorporated by reference herein. Of course, the guide wire 64 is optional as the inner guide member 14 may be placed without the aid or need for the same. Alternatively, the guide wire 64 could be positioned in the frontal sinus initially, prior to placement of the balloon catheter 10.

Now referring to FIG. 10, once the curved portion 16 of the inner guide member 14 is properly positioned, the advancer knob 32 is advanced in the distal direction (arrow A of FIG. 3A) thereby advancing the shaft 30 and attached balloon 36 into the frontal recess 102. This is illustrated in FIG. 10. After the balloon 36 is positioned in the frontal recess 102, the balloon 36 is inflated as illustrated in FIG. 11. Inflation is accomplished by coupling an inflation device (not shown) to the port 38. The inflation device may include a syringe or the like that is depressed to infuse a fluid into the inflation lumen 48 which then passes into the interior of the balloon 36 to effectuate expansion of the balloon 36 to the state illustrated in FIG. 11.

Pressures typically used to accomplish widening or remodeling of the frontal recess 102 are within the range of about 3 atmospheres to about 12 atmospheres. The balloon 36 may be inflated only a single time or, alternatively, the balloon 36 may be inflated, deflated, and inflated again a plurality of times in order to achieve the desired degree of widening. Each inflation step may be performed after positioning the balloon 36 in a different position within the frontal recess 102.

After the frontal recess 102 has been widened or otherwise remodeled, the balloon 36 is deflated and removed as illustrated in FIG. 12. The widened frontal recess 102 illustrated in FIG. 12 is believed to restore the drainage and aeration function and health of the frontal sinus cavity 104. Deflation of the balloon 36 is accomplished by reducing the fluid pressure within the interior of the balloon 36. For example, the plunger of a syringe or the like that is fluidically coupled to the port 38 may be withdrawn to remove fluid from the interior of the balloon 36. The balloon dilation catheter 10 can then be withdrawn proximally from the nasal passageway 100.

In certain patients, treatment of one or both frontal sinuses 104 as described above may be adequate. In other patients, additional sinuses may need to be treated, particularly the maxillary and/or anterior ethmoid sinuses. In such patients, a combination procedure may be well suited. The maxillary and/or anterior ethmoid sinuses can be treated with a system such as described in U.S. Patent No. 7,520,876 and U.S. Patent Application Publication No. 2008-0172033, commercially available as the FinESS system by Entellus Medical, Inc. of Maple Grove, MN. Alternatively, other sinuses could be treated more conventionally using surgical techniques such as, for instance, functional endoscopic sinus surgery (FESS).

Also, the sphenoid and/or maxillary sinus outflow tracts could be dilated with the embodiment of the balloon catheter 10 described above. It is also contemplated that the balloon catheter 10, particularly the embodiment of FIG. 7 with a suitable IGS device is incorporated, and with an appropriate shape for the inner support member 14, preferably straight as illustrated in FIG. 6C, could be used to dilate the maxillary sinus outflow tract via the canine fossa route. Suitable access tools are described in co-pending U.S. Patent Application No. 12/038,719, which is incorporated by reference herein. This could be performed without need for additional endoscopic visualization, permitting treatment through a relatively small diameter access passageway into the sinus cavity in the region of the canine fossa.

A small endoscope (not shown) could be utilized, if desired, through the lumen 18 of the inner support member 14 to further aid in visualization of the maxillary sinus outflow tract.

While embodiments of the present invention have been shown and described, various modifications may be made without departing from the scope of the present invention. The invention, therefore, should not be limited, except to the following claims, and their equivalents.

## Claims:

1. A device for dilating the outflow tract of a sinus cavity comprising:  
a metallic inner member having a proximal end and a distal end;  
a shaft coupled to a balloon, the shaft having a first lumen along at least a portion thereof containing the metallic inner member, the shaft having a second lumen operatively coupled to the interior of the balloon; and  
a handle disposed along a proximal portion of the metallic inner member, the handle comprising a moveable knob operatively coupled to the shaft, wherein distal advancement of the knob advances the shaft and balloon over the metallic inner member in a distal direction.
2. The device of claim 1, wherein the metallic inner member comprises a lumen along a length thereof.
3. The device of claim 2, further comprising a flexible wire dimensioned for slidable movement within the lumen of the metallic inner member.
4. The device of claim 1, wherein the distal end of the metallic inner member comprises a curved portion.
5. The device of claim 4, wherein the distal end of the curved portion terminates in a straight segment.
6. The device of claim 4, wherein the curved portion has a radius of curvature of between 0.25 inches and 1.5 inches.
7. The device of claim 1, wherein the distal end of the metallic inner member comprises a bulbous tip.
8. The device of claim 1, wherein the distal end of the metallic inner member comprises a malleable portion.



9. The device of claim 1, wherein the shaft is helically wrapped about a length of the metallic inner member along a portion of the handle.
10. The device of claim 1, further comprising at least one tracking element disposed at the handle.
11. The device of claim 1, wherein the metallic inner member is replaceable within the handle.
12. The device of claim 1, wherein the handle includes a slot and a portion of the knob is slidably disposed within the slot.
13. The device of claim 12, wherein the slot is between 1 and 2 inches in length.
14. The device of claim 1, wherein the handle includes a stop.
15. The device of claim 1, wherein the metallic inner member is a stainless steel tube having an inner diameter in the range of between 0.020 inches and 0.050 inches and a wall thickness in the range of between 0.005 inches and 0.020 inches.

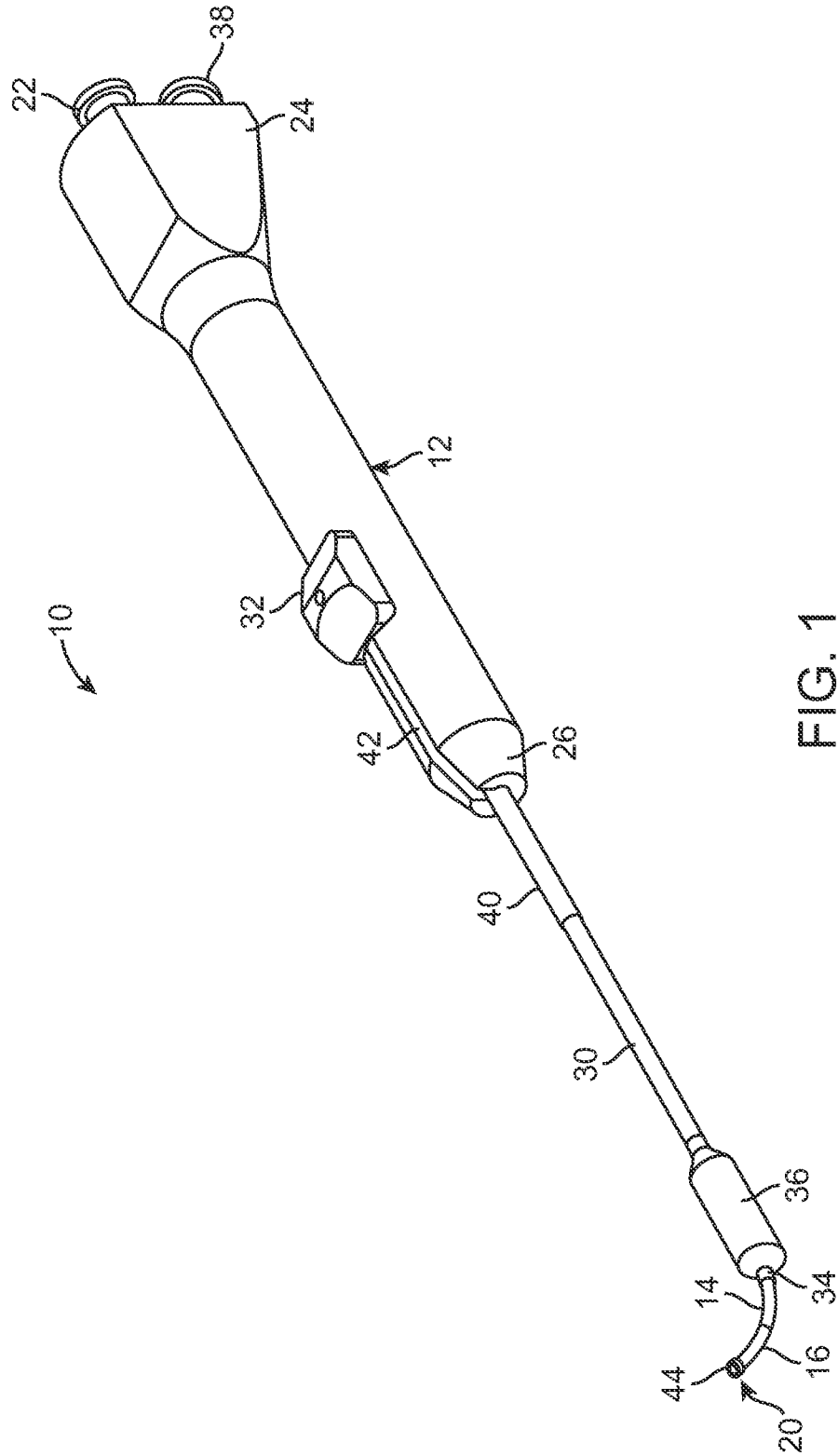
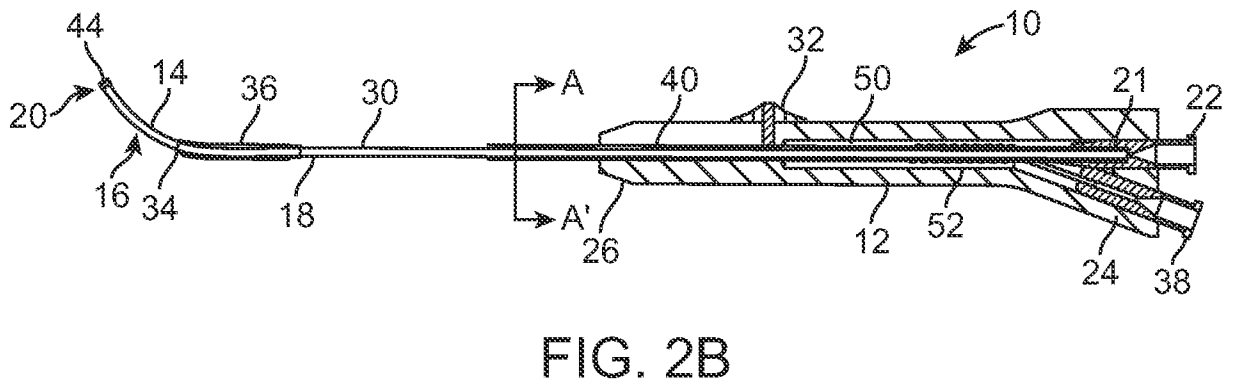
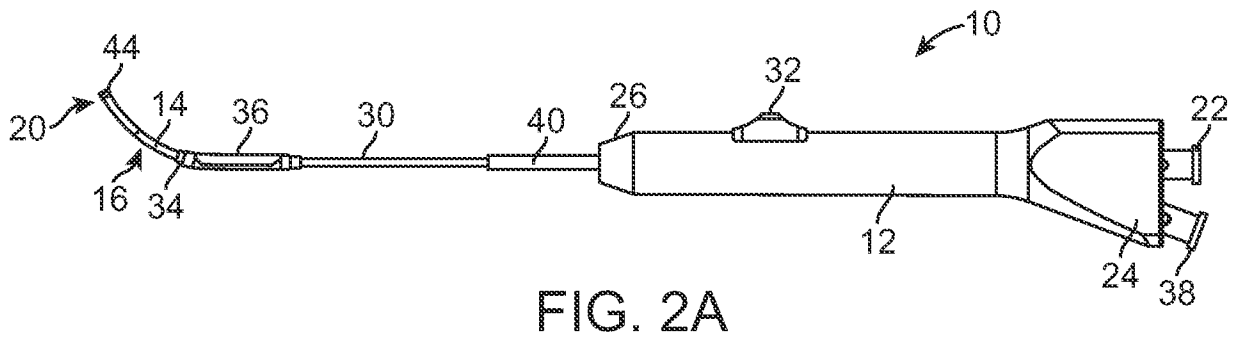

FIG. 1



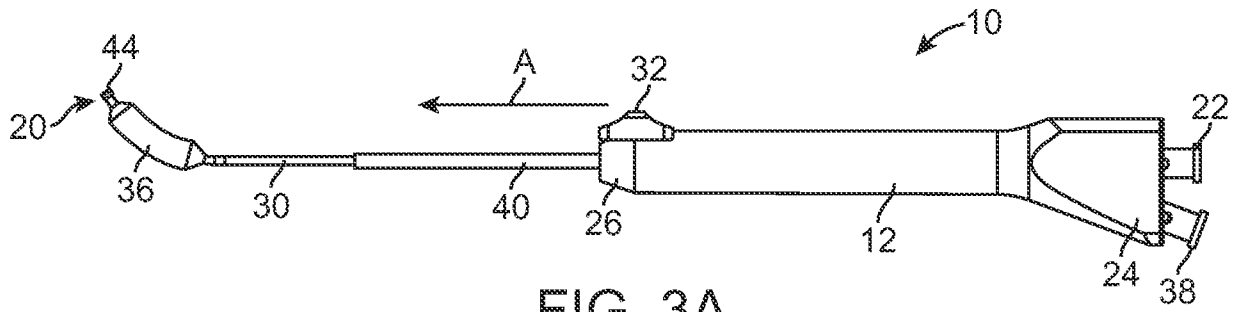

FIG. 3A

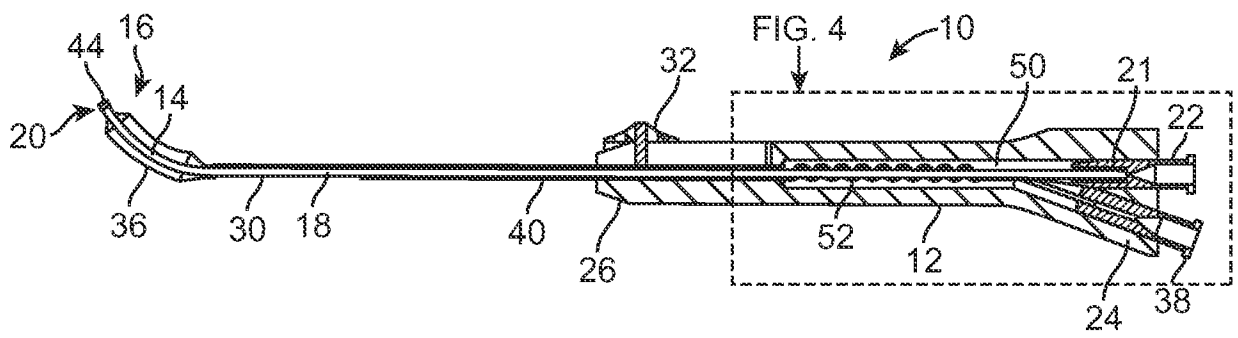

FIG. 3B

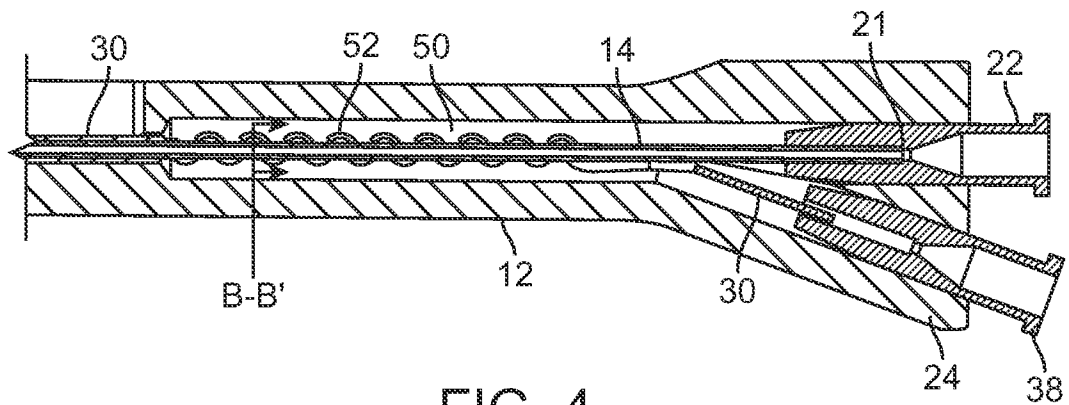

FIG. 4

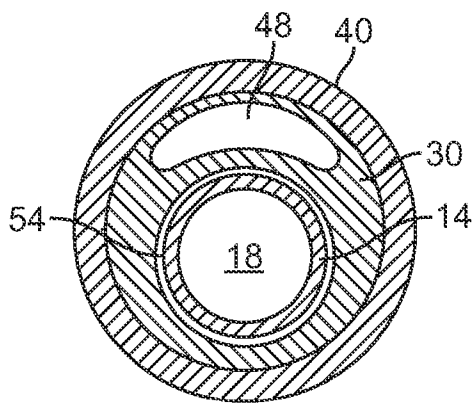

FIG. 5A

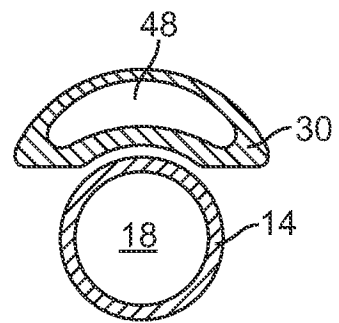

FIG. 5B

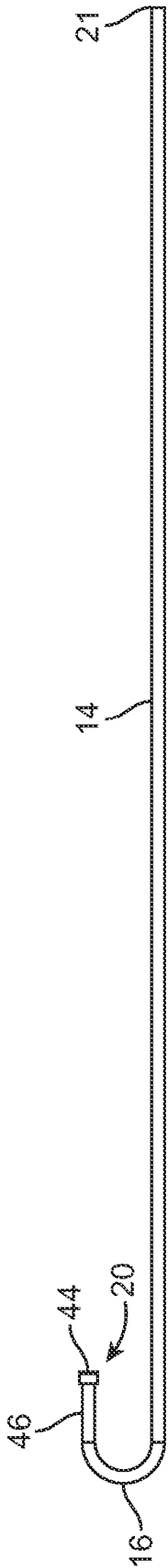

FIG. 6A

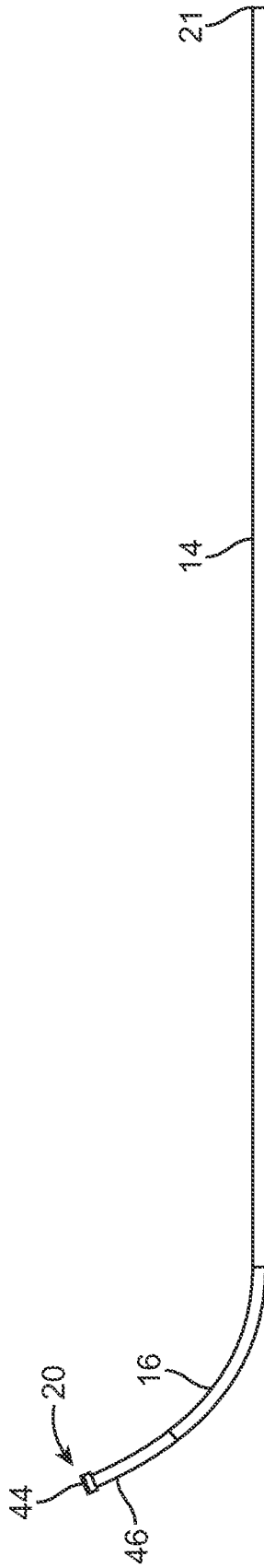

FIG. 6B

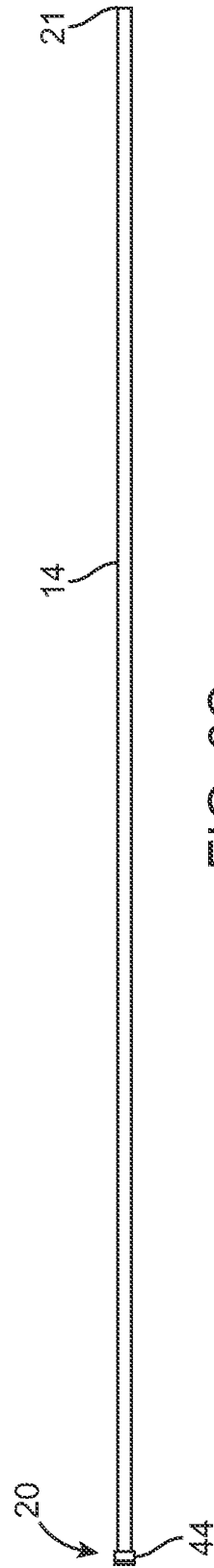

FIG. 6C

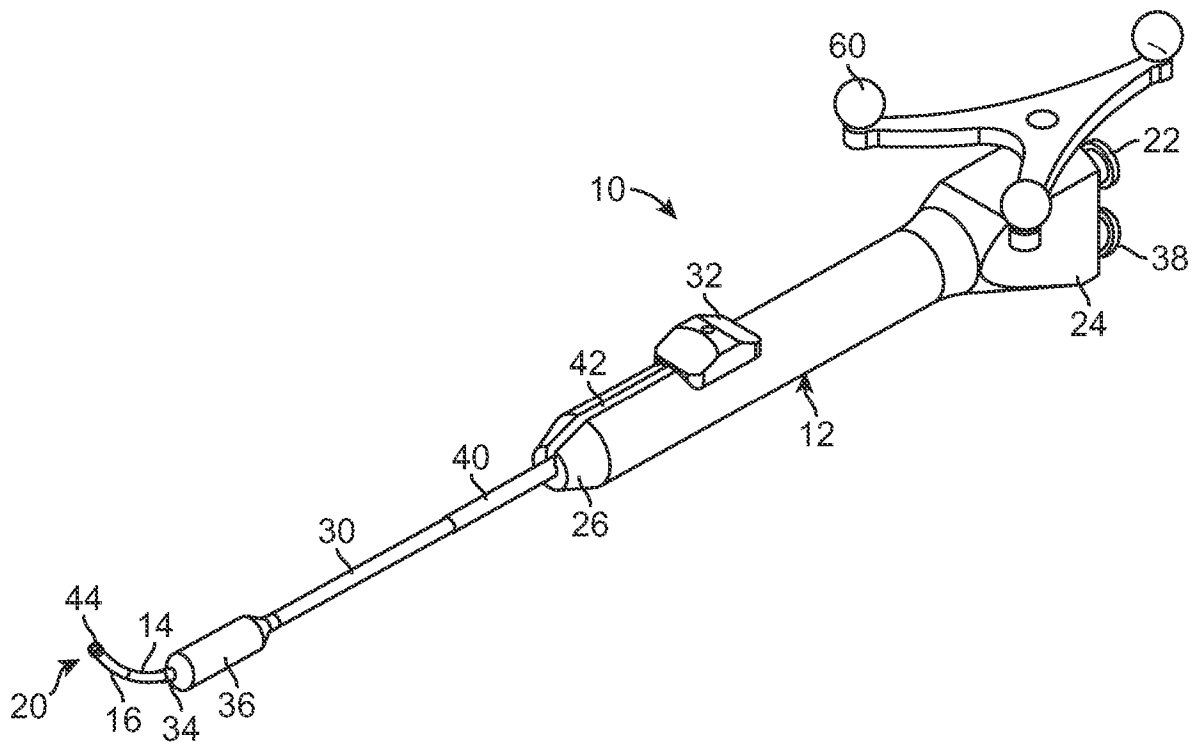

FIG. 7

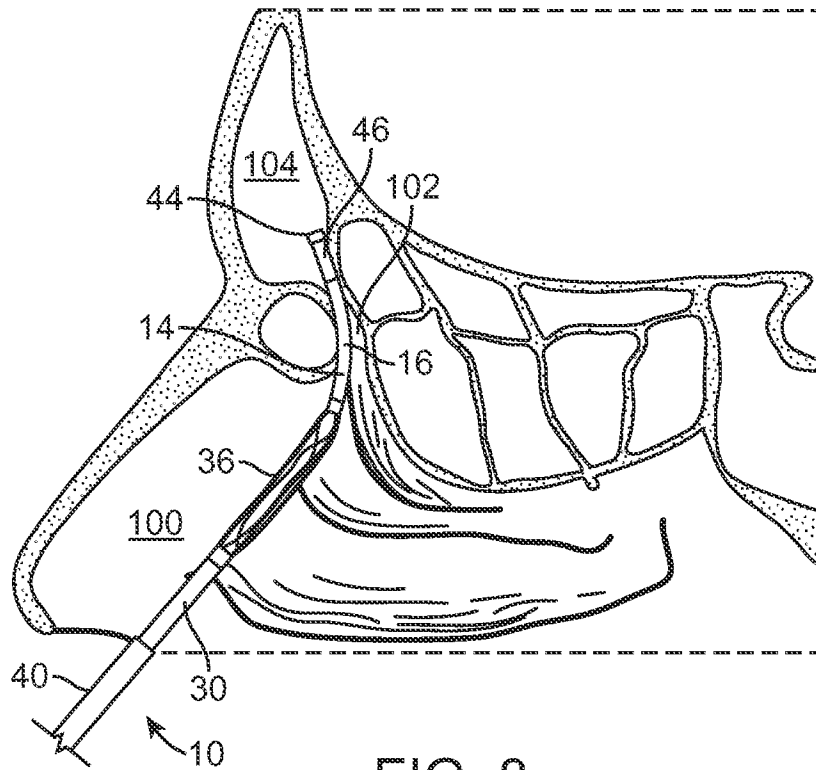

FIG. 8

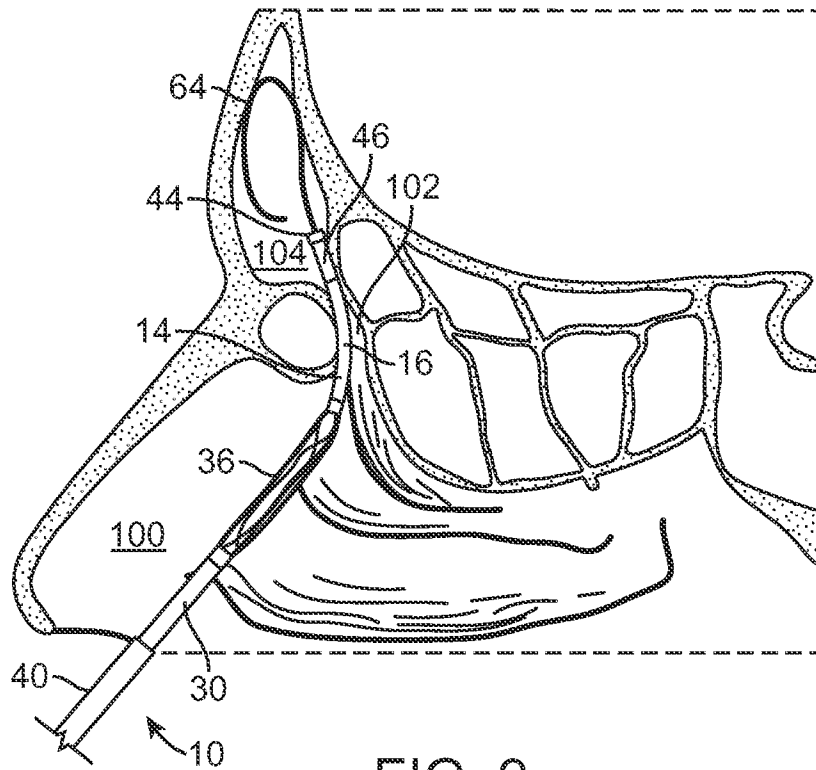

FIG. 9



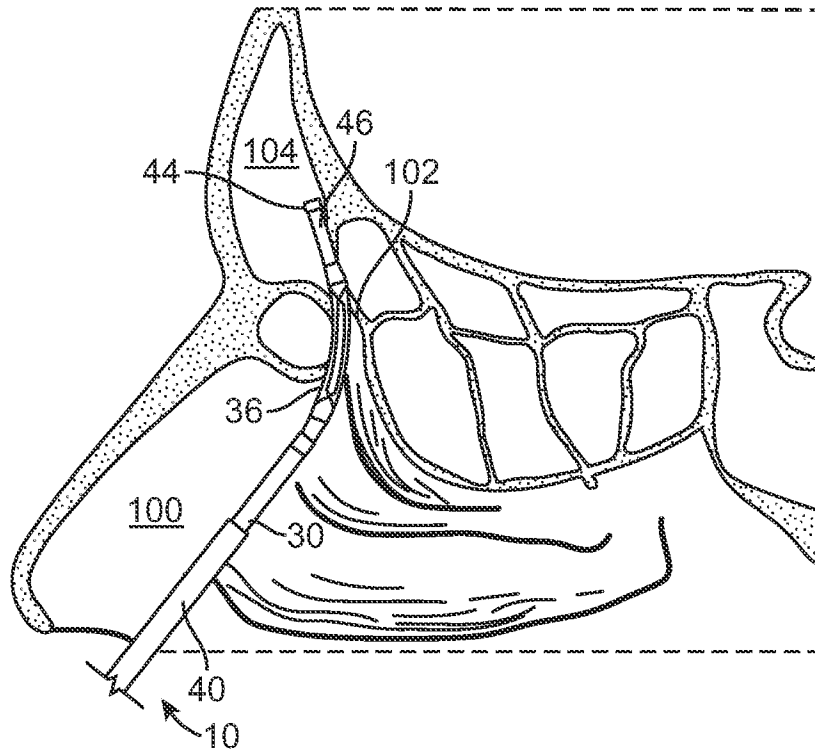

FIG. 10

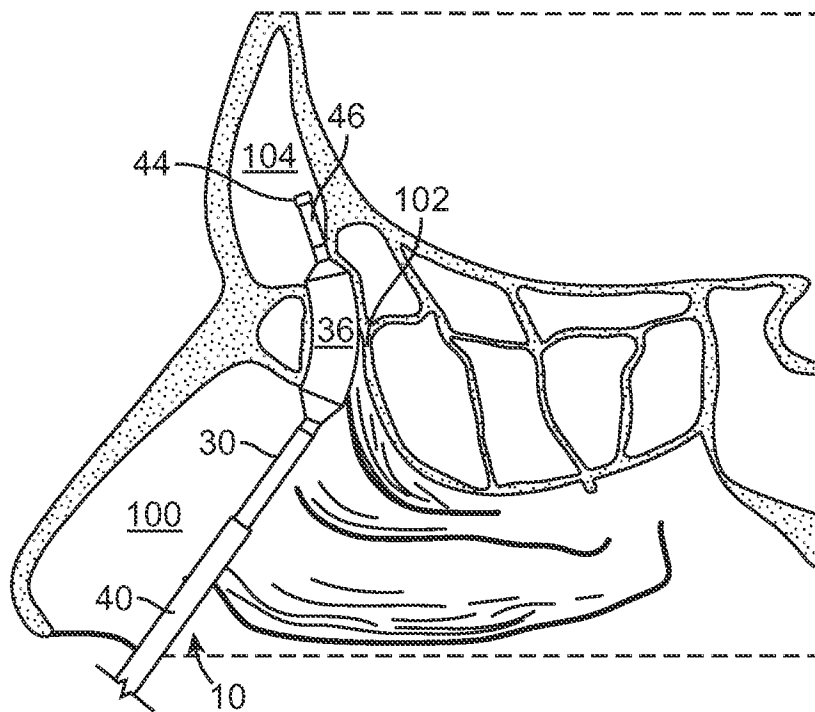

FIG. 11

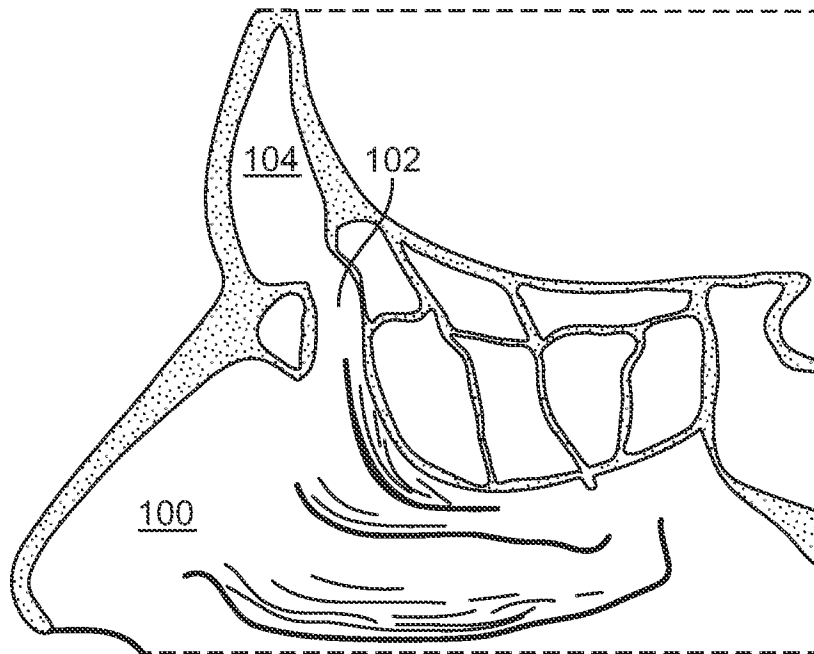

FIG. 12

INTERNATIONAL SEARCH REPORT

International application No.  
PCT/US2010/037508

<p><b>A. CLASSIFICATION OF SUBJECT MATTER</b>                  IPC(8) - A61M 25/01 (2010.01)                  USPC - 600/585                  According to International Patent Classification (IPC) or to both national classification and IPC</p>														
<p><b>B. FIELDS SEARCHED</b>                  Minimum documentation searched (classification system followed by classification symbols)                  IPC(8) - A61M 25/01 (2010.01)                  USPC - 600/585</p> <p>Documentation searched other than minimum documentation to the extent that such documents are included in the fields searched</p> <p>Electronic data base consulted during the international search (name of data base and, where practicable, search terms used)                  Patbase</p>														
<p><b>C. DOCUMENTS CONSIDERED TO BE RELEVANT</b></p> <table border="1"> <thead> <tr> <th>Category*</th> <th>Citation of document, with indication, where appropriate, of the relevant passages</th> <th>Relevant to claim No.</th> </tr> </thead> <tbody> <tr> <td>Y</td> <td>US 2008/0015472 A1 (RESSEMANN et al) 17 January 2008 (17.01.2008) entire document</td> <td>1-15</td> </tr> <tr> <td>Y</td> <td>WO 1996/00033 A1 (RAPACKI et al) 04 January 1996 (04.01.1996) entire document</td> <td>1-15</td> </tr> <tr> <td>Y</td> <td>US 2004/0068299 A1 (LASKE et al) 08 April 2004 (08.04.2004) entire document</td> <td>9, 11</td> </tr> </tbody> </table>			Category*	Citation of document, with indication, where appropriate, of the relevant passages	Relevant to claim No.	Y	US 2008/0015472 A1 (RESSEMANN et al) 17 January 2008 (17.01.2008) entire document	1-15	Y	WO 1996/00033 A1 (RAPACKI et al) 04 January 1996 (04.01.1996) entire document	1-15	Y	US 2004/0068299 A1 (LASKE et al) 08 April 2004 (08.04.2004) entire document	9, 11
Category*	Citation of document, with indication, where appropriate, of the relevant passages	Relevant to claim No.												
Y	US 2008/0015472 A1 (RESSEMANN et al) 17 January 2008 (17.01.2008) entire document	1-15												
Y	WO 1996/00033 A1 (RAPACKI et al) 04 January 1996 (04.01.1996) entire document	1-15												
Y	US 2004/0068299 A1 (LASKE et al) 08 April 2004 (08.04.2004) entire document	9, 11												
<p><input type="checkbox"/> Further documents are listed in the continuation of Box C. <input type="checkbox"/></p>														
<p>* Special categories of cited documents:</p> <table border="0"> <tr> <td style="vertical-align: top;"> <p>"A" document defining the general state of the art which is not considered to be of particular relevance</p> <p>"E" earlier application or patent but published on or after the international filing date</p> <p>"L" document which may throw doubts on priority claim(s) or which is cited to establish the publication date of another citation or other special reason (as specified)</p> <p>"O" document referring to an oral disclosure, use, exhibition or other means</p> <p>"P" document published prior to the international filing date but later than the priority date claimed</p> </td> <td style="vertical-align: top;"> <p>"T" later document published after the international filing date or priority date and not in conflict with the application but cited to understand the principle or theory underlying the invention</p> <p>"X" document of particular relevance; the claimed invention cannot be considered novel or cannot be considered to involve an inventive step when the document is taken alone</p> <p>"Y" document of particular relevance; the claimed invention cannot be considered to involve an inventive step when the document is combined with one or more other such documents, such combination being obvious to a person skilled in the art</p> <p>"&amp;" document member of the same patent family</p> </td> </tr> </table>			<p>"A" document defining the general state of the art which is not considered to be of particular relevance</p> <p>"E" earlier application or patent but published on or after the international filing date</p> <p>"L" document which may throw doubts on priority claim(s) or which is cited to establish the publication date of another citation or other special reason (as specified)</p> <p>"O" document referring to an oral disclosure, use, exhibition or other means</p> <p>"P" document published prior to the international filing date but later than the priority date claimed</p>	<p>"T" later document published after the international filing date or priority date and not in conflict with the application but cited to understand the principle or theory underlying the invention</p> <p>"X" document of particular relevance; the claimed invention cannot be considered novel or cannot be considered to involve an inventive step when the document is taken alone</p> <p>"Y" document of particular relevance; the claimed invention cannot be considered to involve an inventive step when the document is combined with one or more other such documents, such combination being obvious to a person skilled in the art</p> <p>"&amp;" document member of the same patent family</p>										
<p>"A" document defining the general state of the art which is not considered to be of particular relevance</p> <p>"E" earlier application or patent but published on or after the international filing date</p> <p>"L" document which may throw doubts on priority claim(s) or which is cited to establish the publication date of another citation or other special reason (as specified)</p> <p>"O" document referring to an oral disclosure, use, exhibition or other means</p> <p>"P" document published prior to the international filing date but later than the priority date claimed</p>	<p>"T" later document published after the international filing date or priority date and not in conflict with the application but cited to understand the principle or theory underlying the invention</p> <p>"X" document of particular relevance; the claimed invention cannot be considered novel or cannot be considered to involve an inventive step when the document is taken alone</p> <p>"Y" document of particular relevance; the claimed invention cannot be considered to involve an inventive step when the document is combined with one or more other such documents, such combination being obvious to a person skilled in the art</p> <p>"&amp;" document member of the same patent family</p>													
<p>Date of the actual completion of the international search 23 July 2010</p>		<p>Date of mailing of the international search report <b>02 AUG 2010</b></p>												
<p>Name and mailing address of the ISA/US                  Mail Stop PCT, Attn: ISA/US, Commissioner for Patents                  P.O. Box 1450, Alexandria, Virginia 22313-1450                  Facsimile No. 571-273-3201</p>		<p>Authorized officer:                  Blaine R. Copenheaver                  PCT Helpdesk: 571-272-4300                  PCT OSP: 571-272-7774</p>												