



US00D641678S

(12) **United States Design Patent**
Elmitt

(10) **Patent No.:** **US D641,678 S**

(45) **Date of Patent:** **** Jul. 19, 2011**

(54) **WHEEL OR WHEEL COVER**

(75) Inventor: **Karl-Johann Elmitt**, Eching (DE)

(73) Assignee: **Bayerische Motoren Werke Aktiengesellschaft**, Munich (DE)

(**) Term: **14 Years**

(21) Appl. No.: **29/371,362**

(22) Filed: **Jan. 14, 2011**

(30) **Foreign Application Priority Data**

Jul. 16, 2010 (DE) 40 2010 003 916

(51) **LOC (9) CL.** **12-16**

(52) **U.S. CL.** **D12/209**

(58) **Field of Classification Search** D12/204-213;
301/37.101, 64.101, 65, 64.201

See application file for complete search history.

(56) **References Cited**

U.S. PATENT DOCUMENTS

D452,839 S	1/2002	Muth et al.	
D492,235 S	6/2004	Nordmann	
D514,050 S *	1/2006	Scheu	D12/211
D519,901 S *	5/2006	Panano	D12/209
D522,949 S	6/2006	Elmitt	
D543,493 S *	5/2007	Kim	D12/209
D576,535 S *	9/2008	Chung	D12/209
D590,317 S *	4/2009	Chung	D12/211
D619,070 S	7/2010	Pollmann	

D621,771 S *	8/2010	Truebsbach	D12/211
D630,564 S	1/2011	Baum	
D634,250 S *	3/2011	Matei et al.	D12/209

FOREIGN PATENT DOCUMENTS

DE	40010998.0	3/2001
DE	40104441.6	9/2001
EM	000273651-0002	3/2005
EM	001772922-0011	10/2010
EM	001621541-0004	11/2010
EM	001714668-0002	1/2011

* cited by examiner

Primary Examiner — Stacia Cadmus

(74) *Attorney, Agent, or Firm* — Crowell & Moring LLP

(57) **CLAIM**

The ornamental design for a wheel or wheel cover, as shown and described.

DESCRIPTION

This application contains subject matter related to the following co-pending U.S. design patent application: U.S. application Ser. No. 29/371,126, filed Oct. 27, 2010 and entitled "Wheel or Wheel Cover."

FIG. 1 is a front view of a wheel or wheel cover according to my design; and,

FIG. 2 is a perspective view thereof.

The broken line showing of the rear of the wheel, the bolt holes and center hole in the central hub area is included for the purpose of illustrating environment and forms no part of the claimed design.

1 Claim, 1 Drawing Sheet

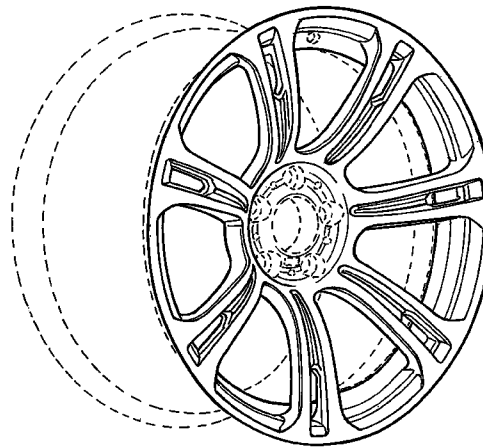
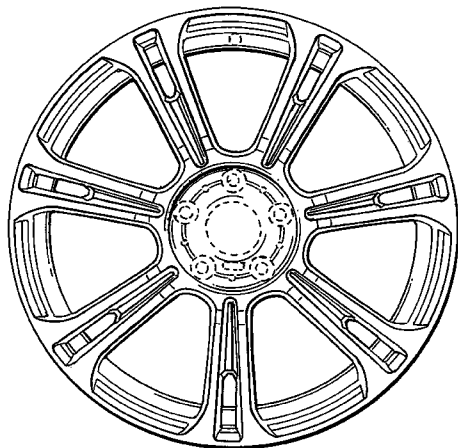

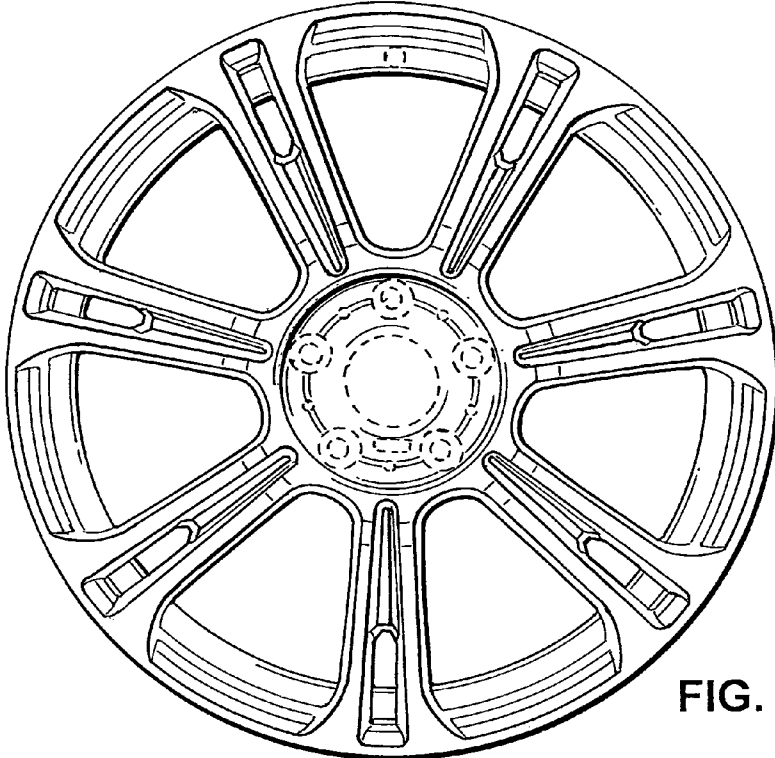

FIG. 1

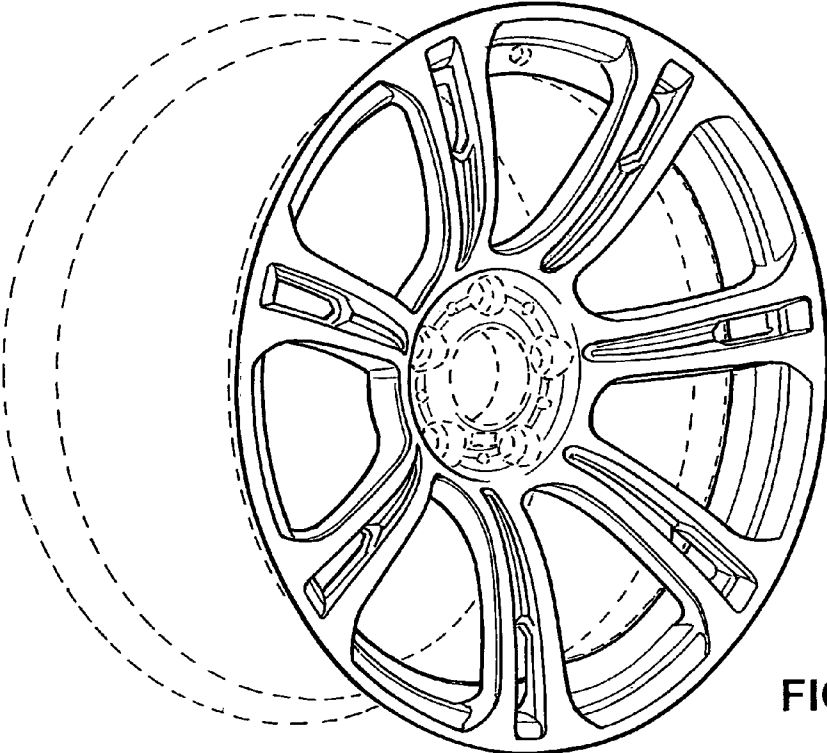

FIG. 2