

(Model.)

2 Sheets—Sheet 1.

J. W. POST.
Lock.

No. 236,660.

Patented Jan. 11, 1881.

Fig. 1.

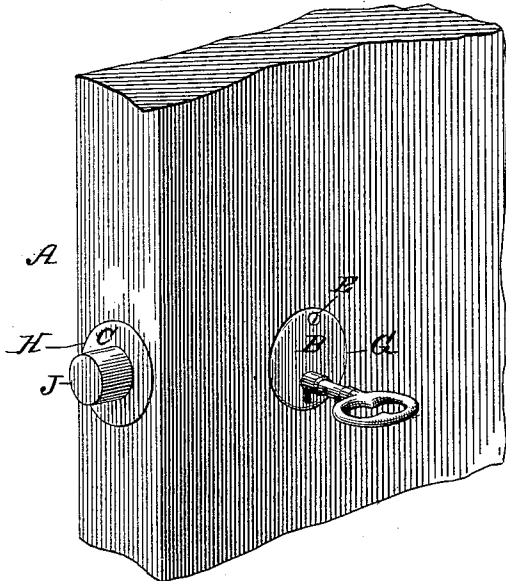

Fig. 2.

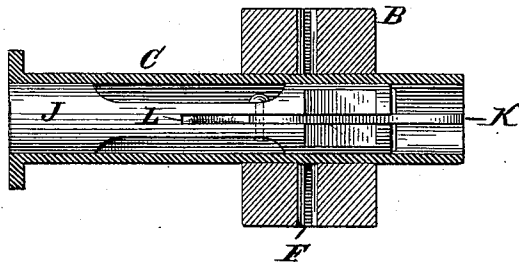
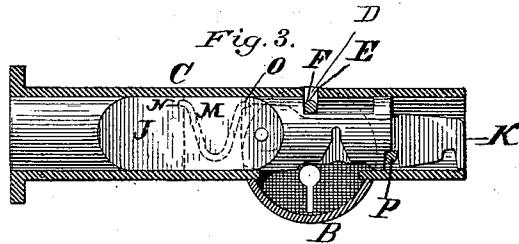

Fig. 3.



Attest:

R. H. Barnes
D. P. Low

Inventor:

John W. Post
by J. R. Nottingham
Atty

(Model.)

2 Sheets—Sheet 2.

J. W. POST.
Lock.

No. 236,660.

Patented Jan. 11, 1881.

Fig. 4.

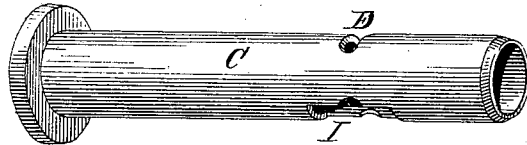

Fig. 5.

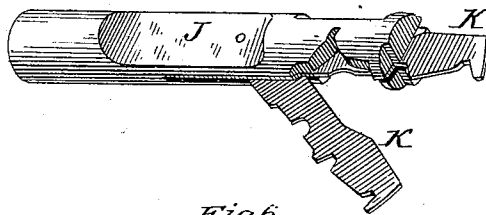

Fig. 6.

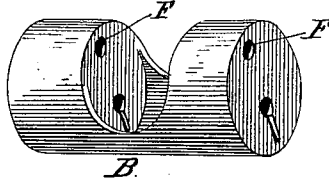

Fig. 7.

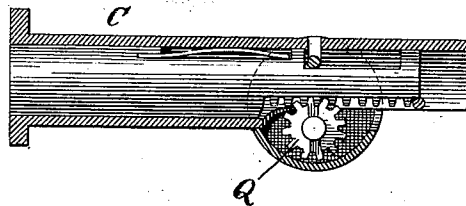
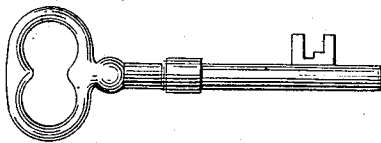

Fig. 8.



Attest:

R. F. Barnes
D. P. Cowl

Inventor:

John W. Post
by J. R. Nottingham

UNITED STATES PATENT OFFICE.

JOHN W. POST, OF NEW YORK, N. Y.

LOCK.

SPECIFICATION forming part of Letters Patent No. 236,660, dated January 11, 1881.

Application filed May 24, 1880. (Model.)

To all whom it may concern:

Be it known that I, JOHN W. POST, a citizen of the United States, residing at New York, in the county of New York and State of New York, have invented certain new and useful Improvements in Mortise-Locks; and I do hereby declare the following to be a full, clear, and exact description of the invention, such as will enable others skilled in the art to which it appertains to make and use the same, reference being had to the accompanying drawings, and to letters or figures of reference marked thereon, which form a part of this specification.

This invention relates to certain improvements in locks of that class known as "mortise-locks," and has for its object to produce a simple and cheap device which can be readily and easily secured to a door, drawer, or box without the use of screws; and it consists in the novel combination and arrangement of parts more fully hereinafter specified. This object I attain by the mechanism illustrated in the accompanying drawings, in which—

Figure 1 represents a perspective view of my improved device as applied to a door; Fig. 2, a horizontal sectional view, showing the cylinders placed in their relative positions; Fig. 3, a vertical sectional view; Fig. 4, a perspective view of the cylinder carrying the bolt and tumblers; Fig. 5, a perspective view of the bolt and tumblers; Fig. 6, a perspective view of the transverse cylinder. Fig. 7 represents a vertical section view of a modification of the bolt and tumbler of my improved device, and Fig. 8 a view of the key to the first-mentioned device.

The letter A indicates a door or drawer; B, the transverse cylinder, and C the bolt and tumbler carrying cylinder. The transverse cylinder is recessed for the reception of the bolt and tumbler carrying cylinder, and is provided with a key-hole in each face or end thereof. The bolt and tumbler carrying cylinder is provided at the top, a short distance from the inner end, with a horizontal slot, D, which is adapted to receive a pin, E, which passes through corresponding holes F at the top of cylinder B after the cylinder C

has been fitted in proper position in the recess in said cylinder B.

In securing the lock to the door or drawer, a hole, G, is bored through the surface of the door or drawer at a proper distance from the edge thereof, and a hole, H, bored in the edge of the door or drawer, extending a short distance beyond the hole G. The transverse cylinder is then placed in the aperture G, the recessed part being upward, and pushed in so that the faces of said cylinder are flush with the surfaces of the door or drawer. The bolt and tumbler carrying cylinder is then inserted in the aperture H until the slot D is on a line with the holes F in the cylinder B, when the pin E is inserted, and the lock is securely attached to the door or drawer.

The cylinder C is also provided at its under side with a longitudinal slot, I, whereby access is had to the working parts of the device.

J indicates the bolt, which is provided with one or more tumblers, K, pivoted and working in a longitudinal slot, L, said tumbler or tumblers being operated by a U-shaped spring, M, one end of which is secured in a hole, N, in the inner end of the slot L of the bolt J, and the other end abuts against a shoulder, O, on the tumbler K; or it may be secured in a hole or slot made in said tumbler.

Passing horizontally through the bolt and tumbler carrying cylinder, near its inner end, is a pin, P, which is for the purpose of holding the bolt J at the various positions to which it may be thrown by the key specially adapted for the device acting upon the wards in the tumblers. As the turn of the key throws the bolt backward or forward the tumbler is caused by the spring M to drop down and engage said pin, and thus securely hold the bolt in position.

In the modification shown in Fig. 7 the bolt J is provided with a rack on its under side and adapted to be engaged by a pinion, Q, operated by a suitable key. The spindle on which the pinion is formed can be turned indefinitely and will not affect the bolt.

Having now described my invention, what I claim, and desire to secure by Letters Patent, is—

In combination with the bolt and tumbler
carrying cylinder, provided with a transverse
slot on one side thereof and a longitudinal
slot on the other, as described, the transverse
5 cylinder provided with key-holes in opposite
faces, with a recess at one side, forming a seat
for said tumbler and bolt cylinder, and aper-
tures for the insertion of a pin, said pin pass-
ing through the transverse cylinder, and the
10 transverse opening in the bolt and tumbler

carrying cylinder, whereby the said cylinders
are secured together and locked in place in
the door, substantially as specified.

In testimony whereof I affix my signature
in presence of two witnesses.

JOHN W. POST.

Witnesses:

E. D. EDGERTON,

R. H. ROOT.