

No. 781,624.

PATENTED JAN. 31, 1905.

W. J. STERLING.
TRUCK.

APPLICATION FILED MAR. 7, 1904.

2 SHEETS—SHEET 1.

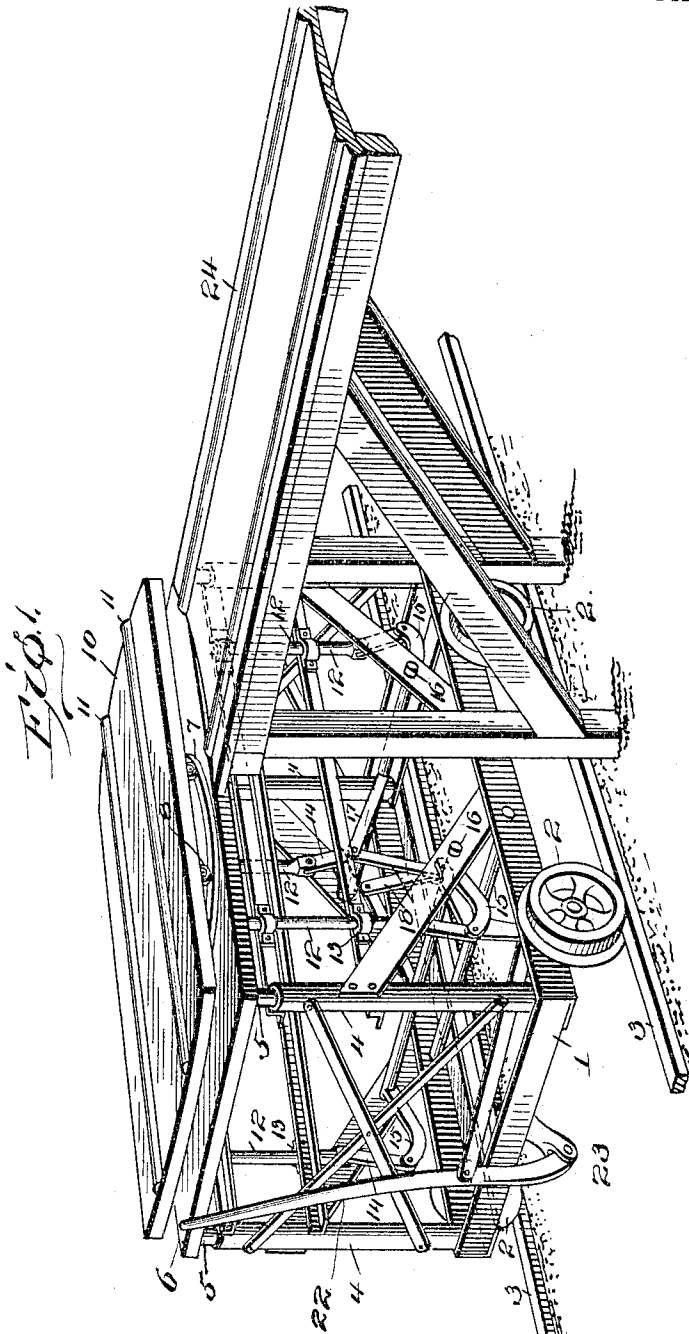

Witnesses

J. M. Fowler Jr.
Edgar M. Kitchen

Inventor

William J. Sterling

By

Mason Lewis Lawrence
his Attorney

No. 781,624.

PATENTED JAN. 31, 1905.

W. J. STERLING.
TRUCK.

APPLICATION FILED MAR. 7, 1904.

2 SHEETS—SHEET 2.

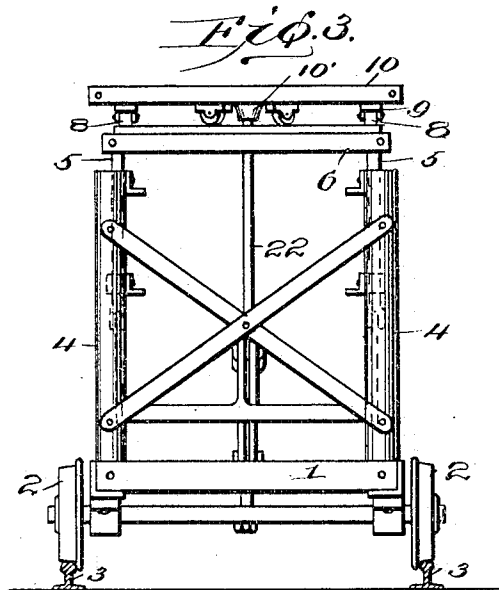
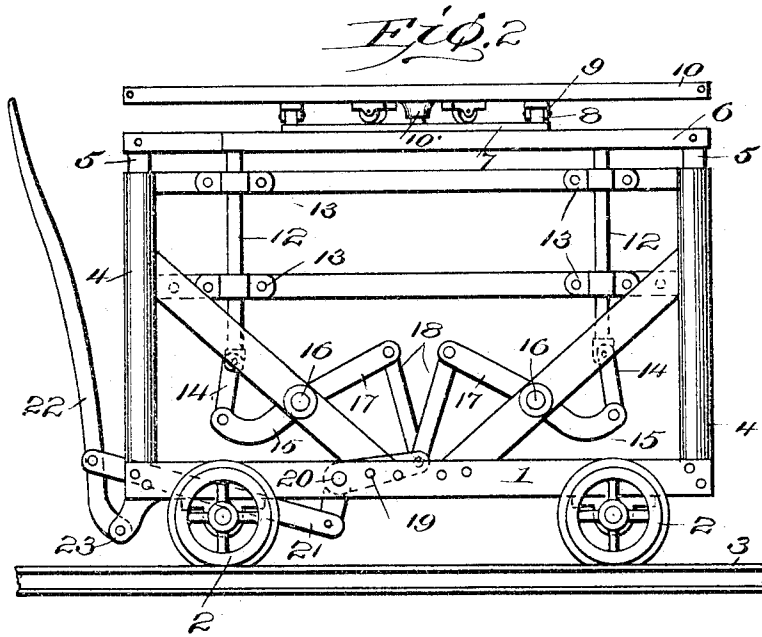

Witnesses

J. M. Fowler
Edgar M. Kitchen

Inventor

William J. Sterling,
By Mason Seawick Lawrence,
his Attorneys

UNITED STATES PATENT OFFICE.

WILLIAM J. STERLING, OF NORFOLK, VIRGINIA, ASSIGNOR OF TWO-THIRDS TO A. S. J. GAMMON AND C. C. GRAVES, OF NORFOLK, VIRGINIA.

TRUCK.

SPECIFICATION forming part of Letters Patent No. 781,624, dated January 31, 1905.

Application filed March 7, 1904. Serial No. 197,048.

To all whom it may concern:

Be it known that I, WILLIAM J. STERLING, a citizen of the United States, residing at Norfolk, in the county of Norfolk and State of Virginia, have invented certain new and useful Improvements in Trucks; and I do hereby declare the following to be a full, clear, and exact description of the invention, such as will enable others skilled in the art to which it appertains to make and use the same.

This invention relates to improvements in trucks, and particularly to the brick-elevating type.

The object in view is the provision of means, in combination with a truck-frame, for supporting a building-block or other brick and means for facilitating movement of said support in a plurality of planes.

With this and further objects in view the invention comprises, in combination with a truck-frame, a support vertically movable thereon, means for moving said support, and a supporting-table horizontally movably mounted upon said vertically-movable support.

It further consists in certain other novel constructions, combinations, and arrangements of parts, as will be hereinafter fully described and claimed.

In the accompanying drawings, Figure 1 represents a perspective view of a truck embodying the features of the present invention. Fig. 2 represents a view in side elevation of the same. Fig. 3 represents a view in end elevation thereof.

In the brick-making art it is common to employ trucks for conveying the molded brick from the mold to a suitable place for drying, the bricks being usually supported upon pallets, and by the present improved structure I contemplate providing means for delivering bricks, with their pallets, to side-lines of tracks extending at right angles to the track supporting the truck, and this result is attained by the employment of the elements disclosed in the accompanying drawings, in which—

1 represents a suitable truck-frame provided with supporting-wheels 2 2, adapted to run upon tracks 3. The frame 1 consists of any suitable angle-bars and other suitable braces

and plates and tubular corner-posts 4 4. Within the posts 4 telescopically extend supporting and guiding rods 5 5, which rods carry at their upper end a supporting-table 6. The table 6 is formed with a suitable raceway 7, preferably centrally thereof, in which run the rollers 8 of casters 9, carried by a turntable 10, said turn-table being retained in position by any preferred form of pivot 10'. The table 10 is preferably provided with suitable tracks 11 11, adapted to receive the rollers of brick-carrying pallets. The table 6 is vertically movable and designed to be moved by means of operating-bars 12 12, extending through guides 13 13, carried by parts of the framework 1. To the lower end of each rod 12 is pivotally connected a link 14, two rods 12 being preferably positioned upon each side of the framework 1. To the lower end of each link 14 is pivotally connected the free end of an arm 15.

Rock-shafts 16 16 extend transversely through the framework 1 and at their opposite ends carry the arms 15 and intermediate their length carry actuating-arms 17 17. A link 18 depends from each arm 17, and said links 18 at their lower ends pivotally engage, preferably, a bell-crank lever 19, carried by a shaft 20, mounted transversely in the framework 1. To the lower end of lever 19 is connected a link 21, said link being pivotally attached at its opposite end to an operating-lever 22, intermediate the length of said lever. The lever 22 is pivotally mounted, as at 23 and designed to be swung vertically for actuating the train of power-transmitting elements above mentioned.

The present improved truck is designed to be employed in a yard in connection with the manufacture of building-blocks and adapted to deliver the blocks from the point of manufacture to tracks, such as are illustrated at 24, extending at right angles to the tracks 3, said tracks 24 extending to a suitable point for permitting drying of the bricks delivered thereto. When preparing to deliver a building-block from the point of its manufacture, the truck is moved beneath the block and the free end of lever 22 is swung downwardly,

thus drawing forwardly the links 21, depressing the end of bell-crank lever 19 opposite that connected with link 21, and thereby, through the links 18 and arms 17, rocking shaft 16 and swinging arms 15 upward, whereby the links 14 and rods 12 are caused to move longitudinally upward and lift the table 6, the rods guiding said table in its movement. The tracks 11 are thus caused to come in contact with the rollers on the pallets of the building block or bricks to be conveyed, whereby said block or bricks may be lifted from their former support, and as soon as the truck is free of the brick-making machine the lever 22 may be permitted to move to its former position, thus bringing the tracks 11 into the same horizontal plane with the tracks 24. The truck is next moved along track 3 until it arrives at the desired track 24, and the table 10 is then swung about until the tracks 11 register with the tracks 24, whereby the pallets may be moved off the table onto said tracks 24.

It will be observed that the table 10 makes possible the delivery of the bricks or building-blocks to the track 24 at an angle to the track 3, so that, if desired, any number of radiating tracks 24 may be provided at a terminus of the track 3 and all of said tracks 24 supplied with brick delivered from the table 10.

Having thus fully described my invention, what I claim as new, and desire to secure by Letters Patent, is—

1. In a truck, the combination with a frame and a support movably mounted thereon, of vertically-movable rods engaging said support, rock-shafts journaled in said framework, means for rocking said shafts, and means for imparting movement from said shafts to said vertically-movable rods for elevating and lowering said support.

2. In a truck, the combination with a framework and a support movably mounted thereon, of a shaft mounted in said framework, a lever carried by said shaft, links pivotally connected to said lever, rock-shafts actuated by said links, and means actuated by said rock-shafts for moving said support.

3. In a truck, the combination with a framework and a support movably mounted there-

on, of rock-shafts journaled in said framework, arms projecting from said rock-shafts, links pivoted to said arms, a bell-crank lever engaging said links, means for actuating the said lever, and means actuated by said rock-shafts for moving said support.

4. In a mechanism of the class described, the combination with a truck-frame and a vertically-movable support thereon, of vertically-movable rods connected with said support, guides for said rods, a link pivoted to the free end of each of said rods, a plurality of rock-shafts journaled in said framework, arms carried by said links, arms projecting from said shafts, links depending from said last-mentioned arms, a pivotally-mounted bell-crank lever pivotally engaging said last-mentioned links, an operating-lever outside said framework, and means connecting said operating-lever with said bell-crank lever.

5. In a truck, the combination with a framework and a support movably mounted thereon, of rock-shafts journaled in said framework, a bell-crank lever pivotally carried by the framework, means for actuating said lever, connections between said lever and rock-shafts for rocking the said shafts when the lever is actuated, and means actuated by said shafts for moving said support.

6. In a truck, the combination with a framework, a support, and a slidable device on the framework and secured to the support; of rock-shafts journaled in the framework, means for rocking said shafts, and means actuated by the shafts for moving the sliding device and support.

7. In a truck, the combination with a framework, a support movably mounted thereon, and a slidable device connected to the support; of a bell-crank lever pivotally carried by said framework, means for swinging said lever upon its pivot and connections between said lever and the slidable device for imparting movement to said device when the lever is moved.

In testimony whereof I hereunto affix my signature in presence of two witnesses.

WILLIAM J. STERLING.

Witnesses:

A. S. J. GAMMON,
J. LLOYD GORDON.