



INTERNATIONAL APPLICATION PUBLISHED UNDER THE PATENT COOPERATION TREATY (PCT)

<p>(51) International Patent Classification ⁶ : G01S 5/22, 5/30, 5/18, A61B 8/08</p>	<p>A1</p>	<p>(11) International Publication Number: WO 98/39669 (43) International Publication Date: 11 September 1998 (11.09.98)</p>
<p>(21) International Application Number: PCT/IB98/00534 (22) International Filing Date: 6 March 1998 (06.03.98) (30) Priority Data: 08/812,518 7 March 1997 (07.03.97) US (71) Applicant (for all designated States except US): SONOMETRICS CORPORATION [CA/CA]; Unit 116, 4500 Blakie Road, London, Ontario N6C 1A4 (CA). (72) Inventors; and (75) Inventors/Applicants (for US only): VESELY, Ivan [CA/US]; 1216 Oakridge Drive, Cleveland Hts., OH 44121 (US). SMITH, Wayne [CA/CA]; Unit 27043, 60 North Center Road, London, Ontario N5X 3W0 (CA). (74) Agent: JAFFE, Michael, A.; Benesch, Friedlander, Coplan & Aronoff LLP, 2300 BP Tower, 200 Public Square, Cleveland, OH 44114 (US).</p>	<p>(81) Designated States: AL, AM, AT, AT (Utility model), AU (Petty patent), AZ, BA, BB, BG, BR, BY, CA, CH, CN, CU, CZ, CZ (Utility model), DE, DE (Utility model), DK, DK (Utility model), EE, EE (Utility model), ES, FI, FI (Utility model), GB, GE, GH, GM, HU, ID, IL, IS, JP, KE, KG, KP, KR, KZ, LC, LK, LR, LS, LT, LU, LV, MD, MG, MK, MN, MW, MX, NO, NZ, PL, PT, RO, RU, SD, SE, SG, SI, SK, SK (Utility model), SL, TJ, TM, TR, TT, UA, UG, US, UZ, VN, YU, ZW, ARIPO patent (GH, GM, KE, LS, MW, SD, SZ, UG, ZW), Eurasian patent (AM, AZ, BY, KG, KZ, MD, RU, TJ, TM), European patent (AT, BE, CH, DE, DK, ES, FI, FR, GB, GR, IE, IT, LU, MC, NL, PT, SE), OAPI patent (BF, BJ, CF, CG, CI, CM, GA, GN, ML, MR, NE, SN, TD, TG).</p> <p>Published <i>With international search report. Before the expiration of the time limit for amending the claims and to be republished in the event of the receipt of amendments.</i></p>	

(54) Title: A METHOD FOR CARRYING OUT A MEDICAL PROCEDURE USING A THREE-DIMENSIONAL TRACKING AND IMAGING SYSTEM

(57) Abstract

A method for carrying out a medical procedure using a 3-D tracking and imaging system (1600). A surgical instrument, such as a catheter, probe, sensor, needle or the like is inserted into a living being, and the position of the surgical instrument is tracked as it moves through a medium in a bodily structure. The location of the surgical instrument relative to its immediate surroundings is displayed to improve a physician's ability to precisely position the surgical instrument. The medical procedures include removal of an obstruction from the circulatory system, a biopsy, amniocentesis, brain surgery, measurement of cervical dilation, evaluation of knee stability, assessment of myocardial contractibility, eye surgery, prostate surgery and trans-myocardial revascularization (TMR). In addition, the method of the present invention also finds use in connection with the generation of 2-D echo planes.

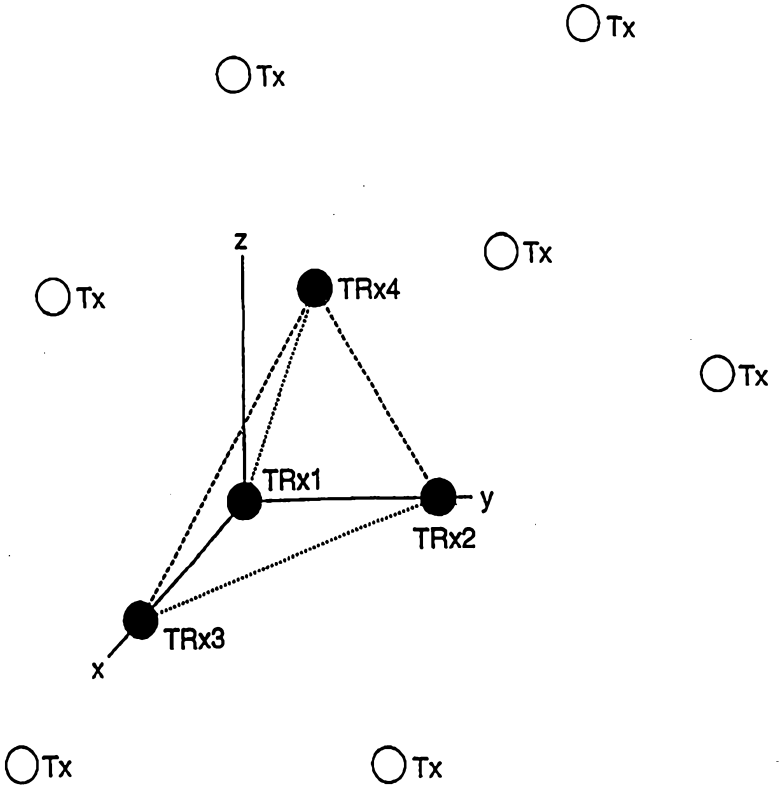

FOR THE PURPOSES OF INFORMATION ONLY

Codes used to identify States party to the PCT on the front pages of pamphlets publishing international applications under the PCT.

AL	Albania	ES	Spain	LS	Lesotho	SI	Slovenia
AM	Armenia	FI	Finland	LT	Lithuania	SK	Slovakia
AT	Austria	FR	France	LU	Luxembourg	SN	Senegal
AU	Australia	GA	Gabon	LV	Latvia	SZ	Swaziland
AZ	Azerbaijan	GB	United Kingdom	MC	Monaco	TD	Chad
BA	Bosnia and Herzegovina	GE	Georgia	MD	Republic of Moldova	TG	Togo
BB	Barbados	GH	Ghana	MG	Madagascar	TJ	Tajikistan
BE	Belgium	GN	Guinea	MK	The former Yugoslav Republic of Macedonia	TM	Turkmenistan
BF	Burkina Faso	GR	Greece			TR	Turkey
BG	Bulgaria	HU	Hungary	ML	Mali	TT	Trinidad and Tobago
BJ	Benin	IE	Ireland	MN	Mongolia	UA	Ukraine
BR	Brazil	IL	Israel	MR	Mauritania	UG	Uganda
BY	Belarus	IS	Iceland	MW	Malawi	US	United States of America
CA	Canada	IT	Italy	MX	Mexico	UZ	Uzbekistan
CF	Central African Republic	JP	Japan	NE	Niger	VN	Viet Nam
CG	Congo	KE	Kenya	NL	Netherlands	YU	Yugoslavia
CH	Switzerland	KG	Kyrgyzstan	NO	Norway	ZW	Zimbabwe
CI	Côte d'Ivoire	KP	Democratic People's Republic of Korea	NZ	New Zealand		
CM	Cameroon			PL	Poland		
CN	China	KR	Republic of Korea	PT	Portugal		
CU	Cuba	KZ	Kazakstan	RO	Romania		
CZ	Czech Republic	LC	Saint Lucia	RU	Russian Federation		
DE	Germany	LI	Liechtenstein	SD	Sudan		
DK	Denmark	LK	Sri Lanka	SE	Sweden		
EE	Estonia	LR	Liberia	SG	Singapore		

**A METHOD FOR CARRYING OUT A MEDICAL
PROCEDURE USING A THREE-DIMENSIONAL
TRACKING AND IMAGING SYSTEM**

Related Applications

The present application is a continuation-in-part (CIP) of co-pending International Application No. PCT/CA96/00194, filed March 24, 1996, which is a continuation-in-part (CIP) of U.S. Application Serial No. 08/411,959 filed March 28, 1995, now U.S. Patent No. 5,515,853.

Field of the Invention

This invention relates in general to a method for carrying out medical procedures, and more particularly to a method for carrying out medical procedures using a 3-D locating and imaging system.

Background of the Invention

Using the time-of-flight principle of high frequency sound waves, it is possible to accurately measure distances within an aqueous medium, such as inside the body of a living being during a surgical procedure. High frequency sound, or ultrasound, is defined as vibrational energy that ranges in frequency from 100 kHz to 10 MHz. The device used to obtain three-dimensional measurements using sound waves is known as a sonomicrometer. Typically, a sonomicrometer consists of a pair of piezoelectric transducers (i.e., one transducer acts as a transmitter while the other transducer acts as

a receiver). The transducers are implanted into a medium, and connected to electronic circuitry. To measure the distance between the transducers, the transmitter is electrically energized to produce ultrasound. The resulting sound wave then propagates through the medium until it is detected by the receiver.

5 The transmitter typically takes the form of a piezoelectric crystal that is energized by a high voltage spike, or impulse function lasting under a microsecond. This causes the piezoelectric crystal to oscillate at its own characteristic resonant frequency. The envelope of the transmitter signal decays rapidly with time, usually producing a train of six or more cycles that propagate away from the transmitter
10 through the aqueous medium. The sound energy also attenuates with every interface that it encounters.

 The receiver also typically takes the form of a piezoelectric crystal (with similar characteristics to the transmitter piezoelectric crystal), that detects the sound energy produced by the transmitter and begins to vibrate in response thereto. This
15 vibration produces an electronic signal in the order of millivolts, that can be amplified by appropriate receiver circuitry.

 The propagation velocity of ultrasound in an aqueous medium is well documented. The distance traveled by a pulse of ultrasound can therefore be measured simply by recording the time delay between the instant the sound is
20 transmitted and when it is received.

 Prior art ultrasound tracking systems suffer from a number of shortcomings which limit their utility. Firstly, conventional sonomicrometers use analog circuitry

to transmit and receive signals (e.g., phase capacitive charging circuits). The voltage representing the measured distance is then output to a strip chart recorder in analog form. This data must then be digitized for computer analysis.

Secondly, conventional ultrasound tracking systems use analog potentiometers
5 to adjust the inhibit time and the threshold voltage that triggers the receiver circuits. This often requires the use of an oscilloscope. Each time the tracking system is used, these settings must be manually set and adjusted in order to tune the system. This can be time consuming and annoying. As a whole, the function of the tracking system cannot be changed. The repetition frequency is fixed, regardless of the number of
10 channels used, and the tracking system is therefore very limited in terms both of the distances that can be measured, and the temporal precision with which the tracking system operates.

Thirdly, conventional ultrasound tracking systems feature pairs of transmitter and receiver crystals that are energized sequentially at fixed repetition rates. As such,
15 prior art tracking systems lack experimental flexibility. For example, before a pair of crystals is implanted in the medium (e.g., a bodily structure, such as a human organ), the user must decide the function of each crystal; similarly, the user must determine which distances are to be measured by which crystal pair. This can be awkward because surgery often necessitates changes during the procedure. If either of the
20 receiver or transmitter crystals malfunctions, the distance between them cannot be measured. Critical measurements can therefore be lost after a significant amount of effort is put into setting up the surgery.

Fourthly, conventional ultrasound tracking systems measure only a straight line distance between any isolated pair of crystals. Three-dimensional information is therefore impossible to acquire. Even if multiple combinations of distances could somehow be linked together, the inherently analog nature of the data would necessitate the use of additional, complex hardware.

Finally, conventional ultrasound tracking systems use discrete elements, such as threshold capacitors and potentiometers requiring large plug-in units to increase the number of channels. The systems are very large, usually two feet wide by 18" deep, and up to 12" high. Additional hardware such as strip chart recorders must be used, for visualization and subsequent processing. This can be very awkward given the space constraints at busy research institutes and hospitals.

The foregoing drawbacks to prior art systems limited their utility, and hence limit the practicality of using the systems to perform various types of medical procedures.

Summary of the Invention

According to the present invention there are provided a variety for methods for carrying out a medical procedure using a three-dimensional tracking and imaging system. The 3-D tracking and imaging system provides enhanced functionality for diverse clinical and medical research applications.

The 3-D tracking and imaging system of the present invention uses modern day digital electronics in conjunction with an integrated personal computer. External A/D converters are not required, as the data is acquired digitally, directly from the

sensors. Due to the speed of the controlling computer, the tracking system of this invention is capable of detecting distance increments as small as 19 μm . The acquired data can be displayed on the computer screen as it is being obtained, and can be saved to the computer's storage media with a simple key stroke. After an experiment or surgical procedure, the saved data can be examined and manipulated according to the user's specifications.

According to a preferred embodiment of the present invention, virtually every function of the 3-D tracking and imaging system is digitally controlled, and therefore very flexible. To begin, a set-up menu is generated which allows the user to select which transducers are active as well as the function of each channel. Next, a data display program permits the parameters of the transducer to be customized for specific applications. For example, if very few channels are being used, the repetition frequency can be increased so that data can be acquired at several Khz. On the other hand, if the system is being used in vitro, where persistent echoes from a container vessel may present a problem, the repetition frequency can be reduced to allow the echoes to attenuate between successive measurements.

The duration of the power delivered to the transducers can be reduced for precision work or increased if greater distances are required to be measured. The duration of the delay required to overcome electromagnetic interference between transducer leads is adjustable by means of a variable inhibit feature. Additionally, the number of samples displayed and stored in any given data save is variable according to the length of time that a user's protocol demands. Finally, the resolution of the

displayed information is variable in conjunction with the degree of motion of the measured specimen. All of these functions are controlled digitally by means of custom designed digital cards or modules discussed in greater detail below, which, in turn, are software controlled.

5 Additional customized software is included in the 3-D tracking and imaging system of the present invention for post processing and visualizing the acquired data. In these routines, stray data points can be easily removed, three point filters can be applied for smoothing, level shifts can remove areas of discontinuity, channels can be derived, beat analyses can be performed, and automatic minimum/maximum level
10 sensing can be applied. Finally, routines can be provided that allow animated data points in a Cartesian coordinate system while providing volumetric and position information.

 The 3-D tracking and imaging system of the present invention overcomes the limitation of prior art transducer pairs. The present system can work with many
15 individual transducers that can be energized sequentially at very high repetition rates, thereby giving the impression that several distances are being measured instantaneously. In reality, the distances are measured in sequence, but since the delay time between successive measurements is in the order of 100 microseconds, the measurements occur virtually simultaneously for most biological applications.

20 Additionally, the 3-D tracking and imaging system of the present invention provides the option of combining the transmitter and receiver circuitry into one transceiver. This provides a researcher with the freedom to affix an array of

transducers to a test object (e.g., catheter, needle, probe, etc.) and then decide which transducers are to function as transmitters and which are to function as receivers.

Moreover, this type of configuration does not need to be limited strictly to transmitter-receiver pairs. By using transceivers, the duty cycle between implanted transducers
5 can automatically alternate between transmit and receive modes, so that every possible combination of distances between a group of transducers can be determined. This type of application is particularly useful for studies which require redundancy of measurement, as well as for establishing in vivo reference frames from which to base three-dimensional tracking.

10 The 3-D tracking and imaging system of the present invention is configurable into a true 3-D mode. In this configuration four or more transceivers are implanted within an object (i.e., specimen) in which distances are to be measured, thereby serving as a mobile reference frame. Multiple transmitters are then attached to the specimen at various locations. Since any three transceivers can send and receive
15 signals, they essentially create an x,y plane. The fourth transceiver is then used to determine the z coordinate of the surrounding transducers by determining if the active transmitter lies above or below the reference plane.

Because the 3-D tracking and imaging system of the present invention uses modern day integrated circuitry and custom programmed logic chips, it is physically
20 much smaller than prior art units. A large part of the system of the present invention is implemented within the user PC (personal computer). The entire unit is composed of three digital computer cards that plug directly into a standard AT computer mother

board. A single cable connection connects the controlling computer and the discrete peripheral transmitter/receiver/transceiver unit. This convenient set-up drastically reduces the amount of experimental space required over prior art conventional units.

Moreover, the 3-D tracking and imaging system allows the position of a device being tracked to be displayed in relation to the surrounding environment using a 3-D template.

The present invention provides a variety of medical procedures which utilizes the unique features of the 3-D locating and imaging system.

Brief Description of the Drawings

A detailed description of the preferred embodiment is provided herein below with reference to the following drawings, in which:

Figure 1 is a schematic representation of four transducers in three-dimensional space, for tracking and triangulating the three-dimensional positions of each transducer, in accordance with the present invention;

Figure 2, comprising Figures 2A, 2B, 2C and 2D, is a schematic diagram of a computer interface architecture used on all digital cards or modules of the preferred embodiment;

Figure 3, comprising Figures 3A, 3B, 3C, 3D, 3E, 3F, 3G, 3H, 3I, 3J, 3K, 3L, 3M, 3N, 3O, 3P and 3Q is a schematic diagram of a controller card architecture according to the preferred embodiment;

Figure 4, comprising Figures 4A, 4B, 4C, 4D, 4E, 4F, 4G, 4H, 4I, 4J, 4K, 4L, 4M, 4N, 4O and 4P, is a schematic diagram of a counter card architecture according to the preferred embodiment;

5 Figure 5, comprising Figures 5A, 5B, 5C, 5D, 5E, 5F, 5G, 5H, 5I, 5J, 5K, 5L, 5M and 5N is schematic diagram of an A/D card architecture according to the preferred embodiment;

Figure 6, comprising Figures 6A, 6B, 6C and 6D, is a schematic diagram of a transmitter/receiver/transceiver architecture according to the preferred embodiment;

10 Figure 7, comprising Figures 7A and 7B, is a timing diagram showing operation of the counter module according to the preferred embodiment;

Figure 8, comprising Figures 8A and 8B, is a timing diagram showing operation of the A/D module according to the preferred embodiment;

Figure 9 is a schematic illustration of a catheter guidance system according to a specific implementation of the present invention;

15 Figure 10 is a schematic diagram of a multiple transducer catheter according to the preferred embodiment;

Figure 11 is a flow chart of a 3-D visualization algorithm which uses the tracking system of the present invention;

20 Figure 12 is a perspective view of a cylindrical or ring-shaped transducer according to a first alternative;

Figure 13 is a perspective view of a ring-shaped array of crystals, according to a second alternative embodiment;

Figure 14 is a perspective view of a composite transducer, according to a third alternative embodiment;

Figure 15 is a schematic illustration of the external reference frame of the catheter guidance system according to the implementation of Figure 9;

5 Figure 16 is a block diagram of the 3-D tracking and imaging system according to a preferred embodiment of the present invention;

Figure 17A is a perspective view of an ultrasound imaging head with a tracking clip attached thereto;

10 Figure 17B is an exploded view of the ultrasound imaging head with tracking clip; and,

Figure 18 is a 3-D scene showing a reference frame, location and direction of a surgical instrument and an ultrasound sector image.

15 **Detailed Description of the Preferred Embodiment**

As discussed above, the ultrasonic tracking system of the present invention utilizes a plurality of transceivers, each of which can be programmed to operate as a transmitter or a receiver. By utilizing four or more transceivers, full three-dimensional measurement capability is provided, as shown in Figure 1. Any three
20 transceivers (TRx1, TRx2 and TRx3) lay in a plane (i.e., the x,y plane). The fourth transceiver (TRx4) may then be used to determine the z coordinates of the surrounding transducers (i.e., multiple crystals Tx) by determining if an active one of

the transmitter transducers lies above or below the reference plane established by transceivers TRx1, TRx2 and TRx3. Each of the many transmitters (Tx) attached to the specimens are sequentially fired, while all reference transceivers record the receiver signals. Since the distance from each transmitter to the reference plane
5 created by the transceivers is known, the relative x , y , z , coordinates of the transmitters can be determined. This is done in real time on a personal computer (PC) with the use of triangulation. This method of networking the transducers is unique to the tracking system of the present invention, and permits the user to trace the three-dimensional motion of an object under investigation. Obviously, the greater the number of
10 transmitters, the better is the reconstruction.

Specific applications of the ultrasonic tracking system which utilize three-dimensional tracking and triangulation, are discussed in greater detail below.

As indicated above, the ultrasonic 3-D tracking system according to the present invention is preferably fully integrated into the standard AT-style computer
15 motherboard found in modern PCs. The three digital cards which comprise the majority of the hardware for the present invention, perform specific, modular functions in the overall operation of the unit. As such, each card is provided with a proper system interface structure in order to be compatible with the ISA architecture of the controlling processor.

20 Figure 2 is a block diagram of the computer interface and addressing scheme common to all three digital cards. It should be noted that the system is classified as an

I/O mapping device as opposed to memory mapping device. Consequently, dedicated I/O registers within the controlling processor are responsible for all data throughput.

As illustrated in Figure 2, the system computer interface architecture features a full two byte data transfer (DO-D15), as well as partial address decoding (A1-A13).

5 Full two byte address decoding is not required. All signals sent to, or taken from the AT bus are buffered using octal buffers (d1 & d2) for both address and control lines, and transceivers (d3 & d4) for the data lines. In terms of decoding, each board features an eight position dip switch (d7) or equivalent for address selection. Address lines A6-A13 are used for this function, thus providing 256 distinct addressing
10 locations, each with a resolution of 40 (hex) (i.e., 26). It should be noted that A0 is not used for address decoding.

An 8-bit magnitude comparator (d5) is used to equate the manually set dip switch with address lines polled by the computer mother board. When a match is found, a signal is generated which gates demultiplexes d8 and d9, each of which is a
15 1-of-8 demultiplexes. The lower three address lines (A1-A3) are used as inputs to both of these Read and Write demultiplexes. To distinguish their functionality, the buffered IOR signal is sent to opposite polarity enables on each demultiplexer. Thus if IOR is in a high state, the system computer interface is in a Write mode. To avoid Reading and Writing from the I/O address ports, A4 is also used as an opposite
20 polarity input to do and do. This has the effect of offsetting the Reads from the Writes by precisely 10 (hex) (i.e., 24). The result of this is two controllable ranges of eight data bits used for gating "reads" from the digital boards, and "writes" to the

digital boards. A single PLD (d6) serves to handle the glue logic between the other components of the decoder circuitry.

Due to the architecture of the x86 family of microprocessors, there are only a finite amount of I/O registers. These registers can be partitioned into either 65535 8-bit registers, or 32767 16-bit registers. Due to the nature of the data transfers to and from the boards, and by selection of an active low signal to the I/O CS16 input of the AT bus, only 16-bit data transfers are employed by the system.

The only remaining control line extending to the digital circuit card is the Address Enable (EN). This signal is used in conjunction with the I/O Read and I/O Write signals to gate the magnitude comparator (d5). By doing so, Direct Memory Access (IQMA) conflicts are avoided between the tracking system and other internal computer modules of the PC.

The first functional module in the ultrasonic 3-D tracking system of the present invention is the controller card. A functional diagram is provided in Figure 3, which comprises Figures 3A, 3B, 3C, 3D, 3E, 3P, 3G, 3H, 3I, 3J, 3K, 3L, 3M, 3N, 3O, 3P and 3Q. The controller card employs the identical bus decoding scheme described above with reference to Figure 2, to govern and pace the functionality of the overall system. As with all of the digital cards, the controller is preferably a four layer Printed Circuit Board, (PCB), with the embedded layers being the power and the ground planes, respectively.

The operation of the card is as follows: A single Programmable Logic Device (PLD), cl, is programmed to cycle through a full two byte count at 32 MHz. The

output registers of c1 are always active, so that the counter is constantly outputting a count value between 065535. These outputs are used for both comparative and timing purposes throughout the system. For this reason, a highly reliable, fast-response PLD is required. Functional blocks C.-C. latch predetermined values from the decoding circuitry, and compare them to the output of c1. Thus, upon system start-up, specific values are written to the registers of C.-C., and once those values are matched by the output of c1, respective signals are generated to govern such features as Pulse Length (6-bit), Cycle Length (8-bit), and Inhibit (15-bit). As illustrated, the "equating" outputs of the low data byte comparison (c2 & c5) require an edge triggering flip-flop (c11) to hold their equated state. The Output of the high data byte comparator (c4) is of sufficient duration to feed directly to c10 and c12. Using a 80 MHz clock, the Pulse Length signal is variable between $0\mu s$ and $2.00\mu s$ at 31.25ns increments, the Inhibit signal between $0\mu s$ and 2.048ms and 62.5ns increments, and the Sub-Cycle Length signal is variable between $0\mu s$ and 2.048ms at $16\mu s$ increments. Typical values are loaded into the registers of c2-c5 to best suit a given application, as discussed in greater detail below.

A second function of the c1 counter is to generate signals to a resetting 1-of-8 demultiplexes (c10) which in turn generates signals for application to c1 and c11 for resetting important system parameters. As can be seen in Figure 3, one of these parameters is the Mode function which governs the direction of data flow in the octal transceivers located on the remaining system cards discussed in greater detail below.

Four c1 outputs are also used to cycle through the RCVR lines of the system, thereby providing a default of 16 receiver modules.

A second major role of the controller card is to manage the performance of the transmitter activation bits. Using a transmitter PLD (c6) as a preloadable up counter, a value indicative of the start transmitter is latched to its input registers. Using an output of the c10 multiplexer as a clocking signal, c6 increments the six transmitter bits and outputs them both to a transparent buffer (c13), and to a 6-bit comparator (c9). Since the transmitter bits are sent to all three digital boards, as well as to the computer peripheral, the transparent buffer is required to avoid capacitive loading.

The ending transmit value is sent to the second side of the 6-bit comparator after it has been latched by c7. The octal latch (c8) is used simply to read the status of the transmitter bits by the controlling software. Once the 6-bit comparison is made and equated, a value is sent out to the local bus to clock the address incrementors on the remaining two digital cards. Although 6-bits are used for equating the transmitter increment bits, the default system allows for a 4-bit transmit value, corresponding to 16 possible transmitter channels. However, higher tier models of the ultrasonic tracking system of the present invention may employ up to 32 transmit cycles, corresponding to a 5-bit transmit value.

An 8-bit latch (c14) is also used by the system to generate and gate signals used to control address counters, interrupt controls, and trigger toggles.

Before most of the signals reach the local bus connecting the digital cards, they pass through c12, which is a simple "glue logic" PLD that ensures correct timing

and signal polarity. This circuit module is also responsible for generating such parameters as the external system trigger for pacing and gating additional laboratory equipment.

Unlike the controller card which generates signals, the counter card (Figure 4) receives signals to consolidate the ultrasonic distance information. The counter card features an external db25 connection to the transmitter/receiver/transceiver peripheral unit (Figure 6). This twenty-four conductor, individually shielded connection between the counter card and the peripheral transmit/receive unit carries the 4-bit transmitter increment signals (TX BITS), the transmitter Pulse Length signals (CSI and CS2) as well as the sixteen default receive lines accommodating 16 transmitter channels (upgradable to 32). Again it should be noted that not all embodiments of the ultrasonic 3-D tracking systems according to the present invention, employ the full range of sixteen receivers. Therefore, where a receive line is unused, it is grounded so as to avoid interfering with the desired signals.

A functional diagram of the counter card or module is provided in Figure 4. The functionality of the counter module is best described in two stages, data writing and data reading. Examining the data writing stage, at precisely the moment when a valid signal is sent out by the external peripheral unit (Figure 6) to activate a transmitting transducer, the expandable bank of receiver PLDs (s10-s13) are reset, to zero. These counters then count up from a zero value in accordance with respective internal 32MHz clocks. Each PLD (s10-s13) is connected to an individual receive transducer (Figure 6). As the 15-bit digital count in each PLD (s10-s13) is

incremented past a predetermined value, an internal register within the PLD is activated which permits the reception of a receive signal. This predetermined value is used to implement the inhibit feature of the system and is designed to block out the electromagnetic interference caused by activating a transmit transducer. Once the mechanical vibration of the transmitted ultrasound is detected by a receive transducer it is converted to an electrical signal, amplified, filtered, and sent back to the appropriate counter PLD. This has the effect of stopping the digital count within the chip.

Next, a 1-of-16 multiplexer (s14) is activated for causing the output enable feature of the counters to be sequentially activated. The captured digital, value corresponding to the separation distance between the active transmitter and each connected receiver is then output in two bytes to the on-board RAM modules (s8 & s9) for temporary storage. Each time the RAM modules are activated, a default of sixteen locations are written to, according to the sixteen default receive signals. This cycle is then repeated for the next transmitter in the system. The incrementing of the RAM addresses is handled by s5, an octal buffer that outputs the 8-bit quantity representing the receiver/transmitter value at any time. Once all the transmitters in the system have been sequentially activated and recorded, the master cycle signal from the controller module triggers s1, the counter address incrementor PLD. This module then increments the RAM addresses to the next major block for the next transmit/receive master cycle.

Typically, the on-board RAM modules s8 & s9 are 8-bit by 131,072. Thus, in the-default configuration of sixteen transmitters and sixteen receivers, the RAM is cycled through 512 times before reaching its capacity. Options exist for upgrading the on-board RAM to 8-bit by 524,288, so as to allow for 2048 complete
5 transmitter/receive cycles. It should be noted that for most biological investigations, a repetition frequency of 200 Hz is demanded. Thus, even with 256kB of storage capacity (128kX2), the on-board RAM can be completely filled in as little as 2.56 seconds. Consequently, the system of the present invention includes software functionality for downloading the stored information. This process is described in
10 greater detail below.

To successfully realize the data reading stage, the counter card or module monitors the addresses that are automatically incremented to the RAM, and writes values to those addresses. This task is carried out by the octal transceivers (s2 & s3). Using the Mode function generated by the controller card, the addressing data shifts
15 from a reading to a writing state in accordance with the system timing. This gives the software the ability to activate any address in the RAM by simply writing out a 16-bit value to s2 and s3. Since the incrementing of the transmitter and receiver bits is automatic, there is no need to monitor their value. Thus, s4 can be simply an octal D-type flip-flop rather than an octal transceiver.

20 Once an address is written to the RAM for data output, the octal buffers s6 and s7 are opened to permit the PLD distance data to be passed along the low and high byte data paths into the I/O registers of the motherboard processor, then to the

computer RAM, and finally to the hard disk for permanent storage. As can be seen in the system timing diagrams (Figures 7 & 8), the system is in a data output mode for the majority of each system cycle. Data input to the RAM occurs regularly, but only for $8\mu s$ intervals.

5 A second major function of the counter module or card is to provide an analog signal output. Despite the fact that digital data acquisition is superior in many ways to conventional analog circuitry, many users are required to work with analog signals. The Digital-to-Analog (DAC) converter (s17) is thereby provided as an option on the standard tracking units of the preferred embodiment. The DAC of the present
10 invention operates as follows. Successive 8-bit values are latched into one side of the one of four magnitude comparator (s15b, d, f & h). These values are selectable through the software to permit any combination of transmitter/receiver output signals to be transferred to the four analog outputs. The opposite side of each comparator (s15b, d, f & h), is directly connected to the constantly cycling transmitter and
15 receiver bits. When the value applied to both sides of a comparator are equal, the output is passed to a 4-to-2 line encoder (s16), before being passed to a DAC (s17). Under this configuration, four distinct, 12-bit analog channels can be connected to an output port from the computer.

 Finally the counter card or module also employ a "glue logic" PLD (s18) to
20 coordinate the timing of the output enable signals, as well as the handling of thirty-two versus sixteen transmit channel capability.

It should be noted that the foregoing counter card is suitably replaced by other types of well known timer modules which are configured to measure transit time.

The final digital card or module in the ultrasonic 3-D tracking system of the present invention is a synchronized Analog to Digital (A/D) converter card or module.

5 During typical experiments, a user may wish to acquire more than the networked distance measurements. For example, in a cardiac investigation, analog signals such as pressure, ECG, and blood flow are also important. For this reason, an expandable A/D card is integrated into the tracking system of the preferred embodiment. The basic system is perfectly provided with four A/D channels. However, up to sixteen
10 independent, 12-bit channels may also be provided ranging from $\pm 10V$.

As illustrated in Figure 5, the A/D module functions in virtually the same fashion as the counter card. Analog channels are fed in via a db25 cable connection (RGB174U coax connectors) to a1-a4. During the data input mode, all analog channels are internally converted fed into two 8-bit by 131,072 RAM modules (a6 &
15 a7). The RAM is automatically incremented using the four gated receiver bits (a13). An incrementing address PLD (a14), which receives the same clock as the counter address incrementor, is used to provide the remaining thirteen address lines to the RAM. Thus, every time a complete transmit receive cycle is performed, both the A/D RAM and the counter RAM registers are increased. During the write, or data output
20 mode, an address is written to the respective octal D-type flip-flop (a12) and transceivers (a10 & a11) to access the proper RAM location. The octal buffers a8 and a9 are opened allowing the converted analog information to be transmitted along the

high and low byte data buses to the computer storage device. Finally, a controlling PLD (a5) is used to coordinate the timing signals on the A/D module. By congruously activating the A/D and counter information, it is possible to synchronize the digital distance information with the converted analog data.

5 A second function of the A/D card is to provide for direct digital inputs. Thus, up to four digital input channels may be received via latch a15 and monitored via octal buffer a8 during an experiment in the same fashion as the analog data.

 The final hardware component in the ultrasonic 3-D tracking system of the present invention is the peripheral transmitter/receiver/transceiver unit, shown in
10 Figure 6. Each peripheral board of the preferred embodiment possesses the capacity to support sixteen transmitters with eight receivers, or eight transceivers. These components are mounted onto a two-layer printed circuit board and connected to the host computer system by means of the twenty-four conductor, individually shielded computer cable discussed above. The external peripheral unit receives its transmit
15 voltage level and biasing voltages from an independent power supply (t5). The unit also possesses a two color LED to indicate whether the unit is in active or standby mode.

 The peripheral unit works as follows. The digital signals from the computer to the unit are passed through pull up resistors to a CMS 1-of-16 decoder (try). The
20 decoded signals are then transmitted to selectable transmitters or transceivers. The variable duration Pulse Length signal is sent via filtering and biasing elements to the gate of an N-Channel Enhancement Mode VMS transistor (Q). The gate signal

bridges the transmit voltage level to ground. This signal is then passed through a step-up isolation transformer (TO) and out of the peripheral unit via a coated, 32 gauge, multi stranded wire (t2) to the transducer (x1).

The transducer (x1) is preferably a cylindrical piezoelectric ceramic crystal, encapsulated with an electrically insulating sealant.

Using a network of similar receivers, the mechanical vibration from a transmitter crystal is detected and converted to an electrical signal. Each individual receiver circuit consists of step-up isolation transformer (T1), a two stage amplifier (A1) collectively providing a 48dB gain, a linear operational amplifier (tr3), a half-wave rectifier (D1) and a TTL level inverter (tr4A and tr4B). The digital waveform output from the TTL inverter is further isolated using an RF choke (t9) before it is transmitted back through the shielded cable to the appropriate LLDS.

According to the best mode of implementing the receiver, the single-ended amplifiers A1 may be replaced by a differential amplifier.

For a further understanding of the operation of the 3-D tracking system according to the present invention, a set of timing diagrams are provided in Figures 7 and 8. These figures illustrate the operation of the counter module (Figure 4) and the A/D module (Figure 5), respectively, during both the read and the write phases of operation. By default, the counter module actively acquires data for sixteen receivers during every Sub-Cycle Length. Conversely, the A/D data acquisition occurs only once during the same time interval, or once every Master Cycle Length. For simplicity, both timing diagrams are based on a transition from a transmitter "x" to a

transmitter "x+1". Despite the apparent equal time-sharing between read and write cycles, in actual fact, the read cycle is significantly longer. More particularly, in the preferred embodiment the write cycle is limited to a $12\mu s$ window per sub-cycle.

Referring to Figure 7, the counter module (Figure 4) operates as follows. At the beginning of the read cycle, an impulse signal is sent out to the VMS transistor (to in Figure 6) to activate a transmit crystal (x1). At precisely the same time, the associated counter PLD (s10a-d, s13a-d) is released from its count of zero and begins counting up at a clock speed of 32MHz. As discussed above, assertion of the CountPLD Inhibit signal prohibits electromagnetic interference between crystal leads by remaining at a logic low level. After a user-adjustable delay, the CountPLD signal changes state, thereby permitting the reception of a valid signal on the associated CountPLD RCVR line (RCVRO-3).

Once the first valid ultrasonic signal is detected and processed, the digital counter value is held on the PLD's output registers. The period of time for this distance count to occur is also variable in duration according to the user's specification. During this time, the transceivers which govern the read/write state of the system permit the downloading of the previously acquired digital distance values from the system RAM (s8,s9) (CountADD OE in a high state). By constantly monitoring the RAM addressing values using s2-s4 (Figure 4) the computer is able to keep track of the RAM status. As the RAM (s8, s9, Figure 4) approaches its capacity, a downloading is carried out during this read window.

The write window of operating the counter module is delimited by the $12\mu\text{s}$ active high Sub-cycle length signal. At the moment this signal is asserted, the following conditions occur: the CountADD OE signal changes state, indicating that the automatic addressing mode has been invoked, the CountBUS DIR signal changes states to allow the opposite flow of data through the transceivers, the CountBUS OE signal is invoked to activate the output registers of the addressing PLD (s1) the CountRAM OE signal is disabled to prepare the RAM (s8, s9) for data storage, the CountPLD OE signal enables cycling through each of the sixteen individual counters, and the CountRAM WE signal toggles to store each digital count value in RAM (s8,s9). The signals used to control these functions are generated by various Boolean combinations of the control module counter (C.). As the default 4-bit receiver values are cycled through to produce the automatic RAM addressing, the CountBUS MODE signal is toggled to sample the current addressing value generated by the addressing PLD (s1, Figure 4). This value is stored in memory for proper downloading of data during the next write window. These functions are carried out during the first $8\mu\text{s}$ of the $12\mu\text{s}$ sub-cycle window.

Once all sixteen receivers (Figure 6) have downloaded their distance data to the RAM (s8, s9), the Master Cycle length value is incremented to indicate the next major cycle. At the same moment, the CountRAM WE signal is disabled along with the polling of the receiver distance values.

Finally the remaining $4\mu\text{s}$ expire putting the counter module back into its read mode, while resetting the receiver chips (COUNTPLD RST), and each of the incrementing counter bits from the controller card (Figure 3).

Using Figure 8 as a guide, the A/D module of the ultrasonic 3-D tracking system works in an identical fashion as the counter module, with one major exception. Write modes occur only during transition of the Master Cycle Length signal. When such occur, the default sixteen converted analog channels are cycled through and written to their respective RAM locations. The same A/D BUS MODE sampling occurs to ensure individual RAM chips are provided in banks of four channels, each chip is given a $2\mu\text{s}$ window in which the A/D CHIP SELECT signal is toggled low for data throughput. At the end of $8\mu\text{s}$, the A/D parameters are reset to their write state while sampling of the analog channels begins once again. once the transition has occurred to activate the next array of transmitters, the AD INTERRUPT signal drops to a logic low value to indicate that the conversions of the active channels are complete.

The machine language codes that carry proper collection and processing of data acquired by the peripheral unit (Figure 6) are all preferably based around a x86 processor. The transfer of information through the system is both quick and seamless. Given a typical system with sixteen transmitters and sixteen receivers, or sixteen transceivers, 256 2-byte distance data saves are carried out every cycle of the Master Cycle length signal. Since the on-board RAM (s8, s9) in a typical unit is 128kB, the RAM has the capacity to save 512 Master Cycles before overwriting occurs. Since

most clinical experiments typically demand a 200Hz data saving rate to sufficiently track biological motion, only 2.56 seconds of data saving can be correctly obtained.

Since this is clearly unsatisfactory for a typical data run, software routines have been written for the system of the present invention to periodically download the RAM modules during the read cycles of the system.

The transfer of information out of the system is as follows: each time the digital boards (Figures 3-5) are accessed, a total of 1024 bytes of data are secured. This 1kB is written to a dedicated 64kB buffer in the mother board RAM of the resident PC. Provided that the computer is not responsible for carrying out any additional tasks, the machine language code implemented thereon, also shunts this information to the display. This function can be performed 64 times before the RAM buffer of the mother board RAM is full. Once this happens, the system software performs a binary save of the data held by the 64kB buffer. At this stage, a standard disk-cache such as DOS's smartdrv.exe is activated to accept all of the 64kB binary files and commit them to the hard disk drive of the PC at the end of a data save command. Under this scenario, the only limit to the duration of a data save is the capacity of the disk cache. In this manner, the ultrasonic 3- D tracking system of the present invention can be tailored to meet the specific needs of customers simply by providing additional memory to the base PC computer.

In addition to data saving and display software, the units according to the present invention preferably also utilize post-processing software routines to manipulate and visualize the saved binary data files.

A three-dimensional (3-D) tracking and imaging system applicable for use in connection with a variety of procedures, including those described in detail below, will now be described with reference to Figure 16. 3-D tracking and imaging system 1600 is generally comprised of a computer system 1620, mobile transducers 1672, reference transducers 1674, an instrument 1670 and an optional robotics subsystem 1690.

Computer system 1620 is generally comprised of a 3-D tracking system 1622, an imaging modality system 1624, an image registration system 1626, an image warping and geometry transformation system 1628 ("warp system"), a user interface 1650 and a display 1660. It should be appreciated that 3-D tracking system 1622 may take the form of a sound-based system or an electromagnetic-based system. Both time of flight and phase relationships may be used to determine distance.

Instrument 1670 may take the form of a catheter (e.g., see Figure 10), a probe, a sensor, a needle, a scalpel, a forcep or other device used in a surgical or diagnostic procedure. Mobile transducers 1672 and reference transducers 1674 may take the form of an ultrasonic transducer or an electronic transducer. However, for purpose of illustrating a preferred embodiment of the present invention, transducers 1672 and 1674 will take the form of ultrasonic transducers (i.e., piezoelectric crystals) described above.

A plurality of mobile transducers 1672 are fitted to instrument 1670. One or more reference transducers 1674 provide a reference position relative to mobile transducers 1672. In this respect, reference transducers 1674 may be located to

provide an internal reference frame inside a patient's body or on the surface of a patient body to provide an external reference frame.

As indicated above, reference transducers 1674 may be transmitters, transceivers or receivers that can generate ultrasound or electromagnetic radiation, that can be detected by mobile transducers 1672.

For the purpose of illustrating a preferred embodiment of the present invention, 3-D tracking system 1622 will take the form of the ultrasonic 3-D tracking system described in detail above. 3-D tracking system 1622 transforms the multiple distance measurements between all of the transducers 1672, 1674 into XYZ coordinates relative to a referenced axis, as described in detail above. It should be appreciated that the reference frame provided by reference transducers 1674 must be self-determining, that is, if the reference frame becomes distorted, this distortion needs to be detected by reference transducers 1674. Detection is typically done by using transceivers that can determine the distance between any combination of two transducers, and hence their relative spacial coordinates in 3-D space. In this regard, the position of the transducers is obtained in 3-D from the images acquired of the bodily structure (e.g., tissue/organ) that show "dots" where the transducers are located, and also from the transducers themselves when they are in the bodily structure. If there is some discrepancy in the distances between all combinations of transducers, then the bodily structure must have deformed (i.e., "warped") after the images were acquired. A mathematical coordinate transformation can be used to specify exactly how to correct the image set and account for the warping. The

distance between any combination of two transducers is determined by having each transducer send a signal to all other transducers. In this way, all the distances between the transducers is known. From these distances, XYZ coordinates can be calculated, in reference to some transducer as the origin.

5 Imaging modality system 1624 acquires 2-D, 3-D or 4-D image data sets from an imaging source, such as fluoroscopy, an MRI (magnetic resonance imaging), CT (computerized tomography) or 2-D or 3-D ultrasound device, to provide a “template” through or against which the shape, position and movement of instrument 1670 being tracked can be displayed. The template typically takes the form of an image of the
10 environment surrounding the instrument (e.g., a bodily structure). It should be noted that if multiple (3-D) volumes are acquired at different time intervals, a 4-D image is obtained (i.e., 3-D image changing over time).

 Image registration system 1626 registers the position of instrument 1570 within the spatial coordinates of the image data set provided by imaging modality
15 system 1624. The position of instrument 1670 is provided by the 3-D tracking system 1622. Image registration system 1626 will provide a display of instrument 1670 at its proper 3-D location inside the bodily structure and orientation relative to the bodily structure itself. It should be appreciated that registration system 1626 may be user assisted, or completely automated if image processing algorithms are implemented to
20 automatically detect the spacial locations of the transducers (typically the reference transducers) in the image data set.

Warp system 1628 is a software-based system that transforms or “warps” the image data sets by the appropriate values to correspond to a deformation that has occurred in the reference frame between the time that the image data set were acquired and the time that the procedure is to be implemented during surgery. Accordingly, warp system 1628 is typically comprised of a matrix transformation routine that maps the deformed geometry onto the original image data set, and distorts it appropriately.

User interface 1650 enables a user to interact with computer system 1620, including programming computer system 1620 to perform a desired function. For example, a particular view for display can be selected. Instruments 1670 (e.g., probes or catheters) can be activated using user interface 1650. Display 1660 displays to the user registered images provided by image registration system 1626.

Optional robotics system 1690 is generally comprised of a robotics control system 1692 and a robotic manipulator system 1694. Robotics control system 1692 controls robotic manipulator system 1694 to follow a programmed path that can be appropriately changed, based on shifting, warping or changes in the shape of a bodily structure at the time of surgery. Robotic manipulator system 1694 physically moves instrument 1670 as instructed by robotic control system 1692.

As discussed above, 3-D tracking and imaging system 1600 can display existing or user acquired image data sets as a template through which, or against which the position, shape or motion of an instrument can be referenced inside the body or organ. The algorithm for carrying out this feature will now be described with reference to Figure 11. It should be appreciated that portions of the “Path 1”

algorithm can run both on the PC that houses the circuit boards embodying Figures 2-6 (“PC”), and/or in a separate computer (not shown) or workstation (“WS”) with additional processing power and 3-D visualization capability.

The process begins with the PC that houses the digital circuit boards. The PC
5 completes a data acquisition cycle and has many numbers in memory, each
corresponding to a time that the ultrasound pulse took to travel the distance between
all combinations of transducers within the measuring volume (module 1100). Within
this volume, there exist a number of mobile transducers mounted on the instruments
being tracked(see Figure 9), as well as reference transducers located on the patient in
10 strategic reference locations (see Figure 15). The reference transducers may be
mounted internal to the patient to provide an internal reference frame, or mounted
external to provide an external reference frame. This propagation delay measure, or
“signal”, can be corrupted with noise, accordingly some signal processing may be
need to be performed to recover the likely values of the original signal (module 1102).
15 This can be done by testing for the range of the signal, and by smoothing or predictive
fitting to previous trajectories of the data signal.

Following signal processing, the improved “signal” is converted in the PC,
according to the methodology discussed in detail above with reference to Figures 2-8,
into “data” that correspond to real measurements of distance between pairs of
20 transducers. This is done by converting the propagation delay into a distance
measurement by taking into account the speed of sound in the particular medium.
This conversion can be a simple linear process, or can be scaled non-linearly,

depending on the likely medium through which the sound is propagating. The output of this conversion is distance measurement "data" (module 1104).

It should be appreciated that the distance measurement data may be corrupted due to signal dropouts resulting from poor signal propagation throughout the measurement volume. However, there usually are more than enough individual distance measurements available to reconstruct the 3-D location of the transducers, since many extra distances between transducer pairs are obtained. A process of "data filling" can be performed to fill in the missing data, based on the many combinations of other distance measurements that are available. "Data filling" can be done using a 'multidimensional scaling algorithm, or variants of it. "Data filling" is an iterative process and is typically done on the computer workstation ("WS"). The output of the "data filling" preprocessing step is more complete data.

The data output from module 1106 is then converted (in a well known manner using geometric algorithms) into 3-D coordinates of the points that are being tracked (module 1108). These 3-D coordinates are passed to a 3-D scene relationship and evaluation module that takes the 3-D coordinates, and based on previously obtained information from user input or a library database, arranges the coordinates in the correct sequence to construct 3-D structures (module 1110). For example, it would be known in advance that, for example, transducers numbered 3, 5, 6 and 9 are mounted on a predetermined one of the instruments (e.g., a catheter), so the coordinates of the transducers mounted to the instrument would be connected together. The scene relationship and evaluation module would then construct a 3-D image that would

represent the position, size and shape of the instrument, based on the 3-D coordinates of the individual transducers mounted to the instrument body.

In a similar manner, the transducers mounted to the instrument can be located in such a way as to build up a 3-D surface patch image of a bodily structure, such as an organ. For example, transducers mounted to a catheter can be located in such a way as to build up a 3-D surface patch image of the inside of a beating ventricle, by simply dragging the catheter along the wall of the ventricle in the area of interest.

The output of module 1110 is a '3-D scene' that contains many of the elements being processed, some of which represent the instrument and the individual transducers affixed to the patient (Figure 15). The 3-D scene is then rendered by a 3-D graphics subsystem rendering/display (module 1112) and output to a display.

If the instrument is stationary, the 3-D scene does not need to be re-rendered or updated in any way. Therefore, a module 1114 is provided that detects any changes in the stream of incoming data. If there are changes, this module signals another module 1116 that determines whether the new 3-D coordinates that have been acquired and processed by the WS have changed significantly from the previously rendered objects or scene. If they have, then this updated information is incorporated into the existing model of the 2-D scene and passed onto the rendering/display module 1112.

The display of the instruments is only one component of the scene relationship and visualization module 1110. In this regard, the instruments need to be displayed in reference to some recognizable features, such as a 2-D or 3-D image showing the

environment surrounding the instrument. The algorithm for carrying out external image acquisition is shown schematically in Figure 11 as "Path 2", and begins with the input of an image from an external image modality (module 1118). As discussed above, system 1600 includes an imagining modality system 1624 providing externally
5 acquired image data sets in 2-D or 3-D form. It should be appreciated that these 2-D or 3-D images may already be in digital form, or may be analog data input directly from a live video source using a frame grabber.

The acquired image data sets must first be converted into a format that is suitable for processing and manipulation inside the WS (module 1120). Accordingly,
10 any analog data is converted to digit data. Therefore, the image data sets that are output from module 1120 are "digital images" that can be manipulated further inside the WS.

The image data sets may need to be preprocessed in some way to make them fit appropriately into the 3-D scene. For instance, if they are to be shown along with
15 the instruments, the image data sets may need to be scaled appropriately. If the images are to be moving, they will need to be updated or reformatted in memory so that they can be output to the 3-D scene rendering/display module 1112 in the correct sequence. Any such manipulation is performed by the preprocessing module 1122. Moreover, for video information, an appropriate sync signal is required for
20 appropriate sequencing (module 1124).

One of the most critical aspects of the 3-D scene relationship and evaluation module 1110 is the placement of the 3-D image of the instrument in the correct spatial

relationship with the underlying images showing the environment surrounding the instrument. This is done by registering features in the images, such as the reference transducers, with their position in the measuring coordinate system. This process uses standard coordinate transformation operations, and only requires for input information
5 as to which feature in the image space corresponds to the same feature (i.e., transducer) in the measurement space. This information can be input by the user during initial set up (module 1126), or can be automatically detected using image processing algorithms. Once the instrument image is registered with the underlying images, the information describing the image set that is to be displayed at a given
10 instant is sent to the 3-D scene relationship evaluator module 1110. Additionally, to test whether new image information has arrived and needs to be used, an appropriate signal is sent to module 1114 that detects changes and instructs the system to update the scene.

For moving image sets, such as 2-D video loops, or 3-D ultrasound loops of
15 the heart, the motion of the image data sets need to be output at a rate that continually matches that of the patient heart beat (see Path 3 in Figure 11). If the image data set that is played back is not synchronized with the current state of the heart, then the 3-D scene will not be displayed in a recognizable format and abnormal motion of the catheters relative to the images, will result.

20 The first step in synchronizing "video loops" with a patient's heart beat is to input a raw ECG signal into the processing computer (module 1128). The ECG signal is converted into digital data using a standard A/D converter (module 1130). The

digital data is then fed into sync generator module 1124, which includes an algorithm that produces a timing signal that corresponds to the current activity of the heart. For example, the sync generator module 1124 can activate a memory location or an input port, or generate an interrupt, at the precise time that a QRS complex is identified.

5 The sync generator module 1124 does this by following the input signal and testing for large rates of change, combined with zero crossing and other information relevant to the expected morphology of the signal. The sync generator module 1124 can run in the PC, the WS, or an external device designed to identify QRS complexes and output a sync signal to the WS.

10 Control information is provided by the user interface (module 1126), discussed above. The user interface checks for user input from a keyboard and/or mouse and sends appropriate control information to the 3-D scene generator (module 1110), and to other modules that can be affected by the user input. Typically, user input would involve the modification of the type of information that is to be displayed on the
15 display screen, and not the way the signals are processed. The user can also assist in registering the catheter location of the instrument with the underlying image set.

The system also has a provision for the merging of other auxiliary data information, such as the display of electric potential over any 3-D structures that are displayed (module 1132). This information is peripheral to this main system, and is
20 assembled in a way that can be readily incorporated into the 3-D scene generator (module 1110).

As indicated above, the transducer of the present invention may take many forms. According to a first alternative embodiment, a cylindrical or ring shaped ultrasonic transducer is provided, as shown in Figure 12, for attachment to an instrument (e.g., a catheter or other probe), for the purpose of tracking its position in three dimensions inside the body or organ. The transducers can be either rigid or flexible. If they are rigid, they are typically constructed from PZT material, and cast or milled into an appropriate shape. If the transducers are made flexible, they are typically constructed from PVDF material that is laminated onto the surface of an instrument. This material is flexible and can be applied to rounded surfaces. As a result of the relatively low transmit efficiency of PVDF material, it is likely to be used for a transducer used in receive mode only. The geometry of the crystal preferably has principal mode of vibration in the 100 kilohertz to 4 megahertz range, or in the range referred to as "low frequency ultrasound". The transducers are polarized along a principal axis (i.e., either through the wall thickness, or along the cylindrical axis) and the appropriate surfaces are coated with a conductive material to facilitate connection to leads. If the material is poled through the wall thickness, then the inner and outer surfaces of the cylinder are plated and conductors are affixed thereto. While the size of the transducer will depend on the application of the tracking technology, the inner diameter of the cylinder is typically 5 millimeters or less for catheters and 5 millimeters or more for larger endoscopic probes. It should also be appreciated that several sections of a cylinder may be placed around the instrument of interest, thus

making each individual transducer small for ease of manufacture, mounting or to control resonant frequency.

As shown in Figure 12, the cylindrical crystal or transducer may incorporate a lossy backing 1200 on which the piezoelectric material 1210 is disposed. The lossy backing prevents excessive ringing of the PZT material. As the crystal is energized, an ultrasound wave propagates both forward and backward. When the ultrasound wave reaches the interface between the crystal and the outside medium (e.g., water or air) it meets an impedance mismatch and most of the wave bounces back into the crystal. This is why the crystal rings for many cycles. The lossy backing enables the backwards traveling wave to exit the crystal (i.e., it has similar impedance) and dissipate with minimal reflection. The backing material is typically epoxy with tungsten powder mixed in. Ideally, the backing material should be many times thicker than the crystal itself.

The piezoelectric material 1210 may be coated with a $1/4$ wavelength matching layer of ultrasound conductive material 1220 (e.g., polymer material). Electrically conductive wires (not shown) are connected to the piezoelectric material. As discussed above, the forward propagating wave of ultrasound typically bounces off of the crystal/water interface, unless some impedance matching material is provided. The purpose of this material is to provide an intermediate impedance between water and PZT so that at each material interface there is less mismatch, and more of the ultrasound wave propagates forward, rather than reflecting backward. Typically one or two layers are deposited on the crystal with intermediate impedances. The

thickness of the layers must be 1/4 of the wavelength of the ultrasound wave so that destructive interference occurs between the reflected waves, thus reducing the ringing of the crystal.

If PVDF is used for the piezoelectric material 1210, then the film or material
5 can be wrapped around the instrument, or could be molded or cast directly upon it, essentially becoming a component of the instrument. It is also contemplated that an existing instrument (.e.g., catheter) can be retrofitted with PVDF material in accordance with the embodiment of Figure 12, to facilitate tracking thereof inside the body. It is also contemplated that the piezoelectric film (e.g., PVDF) can be wrapped,
10 cast or deposited over the instrument in several locations.

According to a second alternative embodiment for the ultrasonic transducer, a ring-shaped array of crystals, or a segmented single crystal can be provided, as shown in Figure 13A, with a configuration that enables the ultrasound energy to radiate at a large angle away from perpendicular to the axis of the cylinder, such that the crystal
15 array functions as a line source of ultrasound energy, or as a collection of point sources, each radiating ultrasound energy in a fan substantially away from the plane of the cylinder, as shown in Figures 13B and 13C.

The crystal is provided with a plurality of facets 1300, each being in the order of a millimeter in size, so as to resonate individually at a resonant frequency dictated
20 by the size of the facet, rather than the size of the entire ring. The ring is plated with a conductor 1310 on both sides, as depicted in Figure 13, rather than on the inner and outer surfaces thereof.

According to a third embodiment of the transducer, a composite ultrasonic transducer is provided comprising a PZT substrate 1400 on a lossy backing 1410. A PVDF film 1420 is bonded to the PZT substrate 1400. This embodiment offers the advantages of high transmitting efficiency of PZT (i.e., conversion of electrical energy into acoustical energy) and the high receiving efficiency of PVDF (i.e., conversion of acoustical energy into electrical energy). It is contemplated that the PVDF and PZT films 1420 and 1400 can be directly connected (as shown), or electrically isolated with appropriate layers of insulator or conductor therebetween. It is also contemplated that the PVDF or PZT structure can be in the form of a slab, as shown in Figure 14, or can be cylindrical, as in the embodiments of Figures 9, 10, 12 or 13.

Figure 15 illustrates the manner in which the external reference transducers are placed. The purpose of the external reference transducer is to provide an external reference frame (i.e., outside the body) to monitor the accuracy and movement of the transducers mounted on the instrument. As can be seen, the transducers are placed in a harness-type apparatus that is worn around the chest by the patient during a surgical procedure. A number of radio-opaque transducers are fastened to the harness in locations suitable for optimal signal reception through the chest cavity. Alternatively, the external reference transducer may be affixed directly to the patient at strategic locations, using self adhesive mounting film or adhesive tape.

Under the disclosed configuration, it is possible to monitor the position and direction of the instruments that are introduced into the body, (e.g., catheters

introduced into the human circulatory system). This methodology significantly reduces both the risk and the procedural time associated with current electrophysiology and angiology operations, while providing improved positioning accuracy.

5 A detailed description of various exemplary medical procedures using the 3-D tracking and imaging system described above, as set forth below.

i) TRACKING OF CATHETERS THROUGH THE HUMAN CIRCULATORY SYSTEM

10 Catheters are devices that are inserted into the veins or arteries of humans as part of a procedure in which qualified hospital personnel, remove blockages and obstructions from the circulatory system, or correct other related problems. The 3-D tracking and imaging system of the present invention may be configured to operate as a catheter guidance system (CGS) that can be used to track various types of instruments, including catheters, probes and needles.

15 The current method of tracking catheters involves frequent exposure of the patient to an x-ray source. Each successive x-ray provides information on the movement of the catheters within the patient. In addition, contrast agents are frequently injected into patients during catheter procedures. These injections can provide further information on the actual location of the catheter and help physicians
20 to plan subsequent catheter movements.

X-ray radiation and contrast agent injections are each potentially harmful to the health of the patient. Further, these methods of tracking are also time consuming, often introducing additional stress and patient complications.

Three primary advantages result from the present invention when used to track catheters:

- 1) The need for using harmful x-rays and contrast agents are virtually eliminated while determining the location of catheters) within the patient;
- 2) Procedure times are substantially reduced with benefits in both safety and cost; and
- 3) Extremely exact positioning of the catheter is obtained as a result of the theoretical resolution of $19\mu\text{m}$, according to the present embodiment of the system.

The basic principle of the catheter guidance system (CGS) of the present invention involves the establishment of an internal reference frame and an (optional) external reference frame in three dimensions from which the catheter can be tracked. Using the transceiver hardware and the triangulation algorithm discussed above, the crystal positioning data can be captured and processed to resolve the location of the catheter of interest.

To further facilitate visualization of the catheter location by the administering hospital staff, the transducer position information may be overlaid onto a recorded video loop of the region of interest. This video loop can be generated from an

imaging modality such as x-ray or scanning ultrasound and is meant to illustrate the natural movement of the biological structures during one or more cardiac cycles. In addition to this, the video loop can also depict the position of the opaque piezoelectric crystals (X1) used by the CGS to track the catheters. These piezoelectric crystals serve as "landmarks" (whether they are internal or external). By identifying these "landmarks" in the video, the positions of the guiding piezoelectric crystals can be correlated with the captured video information. In this fashion, the imaging process and the ultrasound positioning process can be linked for one or more complete cardiac cycles. Once the imaging modalities are linked, the graphic video loop can be substituted for the potentially harmful imaging (and contrast agent injections) throughout the rest of the procedure.

Typically, the catheters used in these procedures are introduced into the body through the femoral vein or artery. From the point of entry, the catheters are pushed and steered, using internal guide wires to the region of interest, usually the human heart. Physically, the catheters are constructed with a biocompatible plastic and feature such options as electrode sensors and actuators for detecting the cardiac activity in electrophysical operations to inflatable balloons for arterial expansion in angiology procedures.

A concept that is of importance in implementing the CGS application of the present invention is the merging of piezoelectric crystals and the imaged catheters. Since the design of catheters used for these procedures are well established,

consideration has been given to the design of the ultrasonic sensor, including the following aspects:

1. The type of piezoelectric material used.
2. The encapsulation procedure.
3. The shape of the transducer.
4. The operating frequency.
5. The activation procedure.

The material selected for use in both the internal and external reference frames must possess superior transmission and reception characteristics in order to properly communicate with each other. Since operating temperatures inside the human body are not a major concern, a higher dielectric material with lower Curie temperature can be employed. Essentially, this provides for an increased ultrasonic output per input volt. The preferred material for this purpose is PZT (lead zirconate titanate).

Since these materials are non-biocompatible, an appropriate encapsulation material is used. The encapsulant must not only be biocompatible, but must also possess an acoustic impedance that does not hinder the ultrasonic wave propagation. This is of key importance for the internal reference frame transducers.

The external reference transducer crystals require an acoustic coupling gel similar to that used for standard B-type ultrasound scans. Omni-directional ultrasound transmission, cylindrical crystals (X1) are used for the internal reference frame. The cylindrical crystals maintain omni-directional radiation patterns while

demonstrating excellent transmission and reception characteristics. Externally, larger disk-type or hemispherical crystals are employed for the reference transducers.

Due to the variable software controls of the 3-D tracking and imaging system according to the present invention, the activation frequency can be optimized for maximum performance and efficiency. In the case of the internal reference frame, smaller distances are monitored, therefore higher activation cycle frequencies can be used. The opposite is true of the external reference frame.

For both reference frames, the method of transducer activation is identical. This process is discussed in detail above with reference to Figure 6. An insulated conducting wire is used to carry the activation impulse from the control unit to the transducers. In the case of the transducers mounted to the catheter, the signal wires are internally routed through the same sheath as the steering guide wires. Finally, placement of the transducers is contingent upon which reference frame is employed. Figure 9 illustrates the placement of the cylindrical transducers with respect to the catheter tip, according to the proposed catheter guidance application of the present invention. As can be seen, two ultrasonic crystals (X1, X2) are used on each catheter. This permits the transducers to communicate with each other, as well as to every other internally placed transducer in the region, and also the external reference transducers. By using the information from two concentric transducers mounted on a catheter, vector data can be acquired to illustrate not only the position of the tip, but also the direction. By using three or more transducers, the curvature and 3-D shape of the catheter can be reconstructed.

As can be seen, the two (or more) crystals (X1, X2) are permanently positioned concentrically along the axis of the catheter (C) at an appropriate separation distance for indicating catheter location, orientation and curvature. The piezoelectric material can be affixed to the catheter with a variety of means, such as a pressfit, bonding, coating or vapor deposition.

One embodiment of the transducer arrangement of Figure 9, is illustrated in cross-section in Figure 10. A multi-lumen catheter 100 (or any other suitable probe) is inserted into the body, such that the 3-D shape or extent of the device can be measured or represented, as discussed in greater detail below. As an alternative to using piezoelectric crystals 110, film patches may be used, such as PVDF (polyvinylidene difluoride). PVDF is not a crystalline material, but a polymer. It is therefore made in sheets or strips and can be affixed to the catheter as a thin, rectangular patch of film. Its principle of operation is similar to that of PZT. PVDF is essentially a piezoelectric material that can be easily molded into different shapes and configurations.

The catheter 100 can be fabricated from any suitable polymer. A wire or wires (not shown) can pass through one of the lumens of catheter 100, or can be incorporated into the polymer during manufacture. The piezoelectric crystals 110 can be partially or completely embedded into the wall of the catheter 100 or can be affixed to the surface thereof. The crystals are preferably mounted on a suitable lossy backing 130 to which electrical conductors 140 are connected. The crystals 110 can also be provided with a dome-shaped polymer lens 150 affixed thereto.

ii) TRACKING OF INTRAVASCULAR ULTRASOUND IMAGING
CATHETERS, BALLOON CATHETERS, AND STENT DEPLOYMENT
CATHETERS THROUGH CORONARY ARTERIES AND THROUGH
PERIPHERAL VASCULATURE

5

The tracking of catheters can be extended into the field of intravascular ultrasound. Intravascular ultrasound imaging is gaining increased acceptance as a means of diagnosing the severity and spatial distribution of atherosclerotic plaque. Intravascular ultrasound imaging involves the placement of ultrasound imaging transducers (e.g. PZT transducers) on the tip of a catheter. The ultrasound imaging transducers rotate to provide a 2-dimensional circular picture of a cross-section of a coronary artery and the local pathology at the level of the artery where the tip of the catheter is located. The ultrasound frequency of commercially available intravascular ultrasound imaging systems is typically 30MHz. An intravascular ultrasound imaging system can detect whether the plaque is calcified or just fibrosed, as well as the overall shape of the blockage and the remaining lumen of the coronary artery. In this regard, calcified plaque procues a shadow behind it, and it can be identified by a trained physician, and sometimes through image processing. A fibrous plaque is often a bump in the wall of the vessels and both proximal and distal edges are visible on an ultrasound image, as the plaque is somewhat transparent to ultrasound, just like the vessel itself. This information is often used as a diagnostic technique to plan interventions such as angioplasty (a balloon dilation of the artery) or intravascular stenting a metallic tube that keeps the artery distended and patent.

10

15

20

25

It has recently become clear that simple 2-D imaging of the artery generated by the ultrasound imaging transducers is not sufficient. Very often, contrast

angiography under continuous fluoroscopy is used to determine where the catheter is sitting relative to the branches of the coronary arteries. Often, it is important to determine if the blockage and lesion is near a bend or not, and also what is the 3-D topography of the lesion. Often, if the lesion is near a bend, a different therapeutic plan may be implemented. For example, if the lesion is at the bend, an intravascular stent would not be deployed in that region. It should be noted that a lesion is visible on across-section of the artery using intravascular ultrasound imaging, and during contrast angiography, is also visible a narrowing of the artery. It should be appreciated that the precise shape of a vent of an artery may determine the way stents are placed.

Three-dimensional reconstruction of the intravascular ultrasound images adds diagnostic value to the procedure. Typically, the intravascular ultrasound images generated by the ultrasound imaging transducers are saved continuously as the ultrasound imaging catheter is slowly pulled back along the coronary artery. These images are then stacked beside each other, and displayed as a 3-D reconstruction of the artery. The problem is that as the ultrasound imaging catheter is pulled back to acquire a series of slices, only the position along the length of the vessel can be measured. The result is that a vessel is always reconstructed as if it were a straight tube. Even a highly tortuous vessel will be reconstructed as a straight tube, since the pull-back distance is measured at the point of entry into the patient, not at the imaging site. Furthermore, the pull-back position is not very indicative of the true distance along the artery. Between the entry point and the imaging tip of the ultrasound

imaging catheter, there are considerable bends. A small pull-back of the ultrasound imaging catheter at the entry point is seldom reflected by a similar motion at the imaging tip. Very often the imaging tip moves as a series of jumps, rather than a smooth continuous motion.

5 The position of the intravascular ultrasound imaging catheter can be easily tracked by mounting a low frequency transmitter near the imaging tip of the ultrasound imaging catheter. By having a dual display showing the view inside the vessel with the ultrasound, and the position of the imaging area relative to the gross morphology of the vessel on the angiogram, the angiologist can better treat the lesions
10 and reduce the procedural risks to the patient.

 The procedure for tracking the ultrasound imaging catheter will now be described in detail. By mounting PZT or PVDF transducers on the imaging tip of the ultrasound imaging catheter and mounting additional reference transducers internal or external to the patient to provide one or more reference frames, the catheter guidance
15 system (CGS) can be used to track the 3-D position of the imaging tip, and the spatial location of the multiple slices can be recorded. The spacing of the slices can be adjusted to reflect non-uniform motion at the imaging tip, and the angulation of slices is also determined from the orientation of the imaging tip. It should be appreciated that the transducers should be placed close enough to the imaging tip of the ultrasound
20 imaging catheter such that its motion can be referenced to the transducers. If the imaging tip is rigid, then two transducers can be placed along the rigid section to obtain a vector perpendicular to the imaging plane. Typically, the imaging

transducers are not located at the imaging tip, but a little further down, since the imaging tip often has a little rubber flexible section to enable easier insertion into an artery.

Tracking the imaging tip enables the reconstruction of the true 3-D shape of the artery with all its twists and bends. Such information is very valuable for the planning of dilation or coronary stenting procedures. During such a procedure, the computer system will typically record the 3-D position of the imaging tip, as well as its angular orientation, and save the data to a file at the same instant that the ultrasound image is saved. During image processing and 3-D reconstruction, this information will be used to reformat and spatially locate the sequential images, such that an accurate shape of the reconstructed artery can be obtained. It should be appreciated that the x,y,z, coordinates of the catheter imaging tip, referenced to time or image number, are saved to enable the reformatting and reconstruction of a 3-D image data set. The same 3-D data set can be used to advance the therapeutic catheters to the appropriate position, using the 3-D tracking procedures described above.

iii) TRACKING OF BIOPSY CATHETERS OR BIOPSY NEEDLES

Biopsies are typically performed to diagnose organ diseases, (e.g., cancer) or organ rejection. The tracking of biopsy catheters is of particular importance, because occasionally the biopsy "bites" are taken from the wrong part of the heart, liver, breast or other tissue or organ to be sampled. This is particularly significant in biopsies that are supposed to be diagnostic of cancer. In breast, liver and other internal organs, the

tissues are highly deformable and catheter-based or stereotactic biopsies are typically not successful. In the case of the heart, sometimes a piece of the coronary artery is cut off, or the cardiac valve is damaged, with obvious complications to the patient. By following the path of the biopsy device, using single or multiple angiograms, x-ray
5 images, or ultrasound image sets and real time overlay of the tracked biopsy catheter, the biopsy procedure itself can be made more precise and safe.

Biopsy needles can also be tracked with ultrasound, such as when cannulating the carotid artery or the femoral artery. Prior art systems rely on having the needle cast a faint shadow in the B-mode ultrasound image. This shadow is not readily
10 visible to the untrained eye, and has obvious limitations in precision. A true 3-D tracking of the needle under real time ultrasound using the principles of the present invention greatly simplifies such procedures.

These procedures for tracking biopsy catheters and biopsy needles can be improved significantly by using an internal reference frame. In this regard, reference
15 transducers are inserted into the surrounding area (internal reference frame) using large gauge needles, or affixed to the surface of the patient (external reference frame), such as in the case of the breast procedures. The transducers mounted to the needle are preferably thin PVDF film, or very small slivers of PVT, embedded in the metal shaft of the needle. Importantly, the transducers must be located such that they
20 surround the area of interest. The bodily structure (e.g., organ or tissue) is imaged as usual, the 3-D image set is registered with the reference transducers, and the procedure performed as described above. The visualization system may provide 3-D

images or a collection of 2-D images, in which the progression of the biopsy catheter or needle can be viewed in real time.

iv) TRACKING OF AMNIOCENTESIS NEEDLES

Another application of the real time tracking system of the present invention in the tracking of needles for use in the procedure of amniocentesis. A 3-D or 2-D image set of the fetus with the motion of the needle displayed, can increase the precision and speed of the procedure and can prevent injury to the fetus. In the case of amniocentesis, the reference transducers are placed on the sides and top of the patient's belly.

v) GUIDING OF PROBES DURING STEREOTACTIC SURGERY

During some delicate surgeries, particularly in the brain, it is important to know precisely the 3-D position of the probe inserted into the head. Typical brain conditions that require the guidance of a probe during stereotactic surgery are removal of brain tumors, the surgical correction of aneurysms, and electrical abnormalities like epilepsy (ablation, destruction of neural tissue).

The conventional method for guiding probes involves rigidly fastening the patient's head to a stereotactic frame by placing screws and pins into the patient's skull. The patient, with the frame attached, is then imaged using MRI or CAT, and a 3-D reconstruction of the patient's head is created. Pathologic tissue or lesions, such as tumors, are then precisely located relative to the frame. The patient is then taken to the operating room and the required instruments, such as electrodes or ablaters, are affixed to guides that allow the instruments to be moved along the specific paths into

the patient's head. Once the surgical instrument is in place, the lesion can be corrected, destroyed or treated in some way. The foregoing approach is tedious, costly and subject to measurement error in translating the 3-D coordinates from the images to the actual position of the probes within the stereotactic frame.

5 An alternative approach involves the use of a 3-D wand. This instrument consists of an articulating metallic arm that is rigidly affixed to a surgical table. Each of the joints in the arm has an angular position sensor so that the 3-D coordinates of the probe tip can be calculated from the joint sensors. By matching visual landmarks on the patient's head to the same landmarks on the 3-D image using the probe, the
10 head and the 3-D image can be registered with each other. The probe is then used during surgery to hold instruments and guide them into the brain in a manner similar to the stereotactic frame. The advantage of the wand is that it has many more degrees of freedom, and can be held by the surgeon. The disadvantage is that it is very expensive, and very bulky. Also, the position of the probe tip is always only as
15 precise as the original calibration against the patient's head. The patient's head must remain rigidly affixed to the table to which the articulating arm is fixed.

 An existing alternative to the 3-D wand is an air-based 3-D locator system, which is the subject of U.S. Patent No. 5,517,990. In this system, the position of a freely held wand is determined using triangulation of audible sound pulses in air. One
20 major disadvantage to this approach is that the air-based 3-D locator system requires microphones to be placed at fixed sites in the operating scene. The patient's head

must still be rigidly affixed to the table and the surgeons must take care not to get in the way of the sound path. This severely limits the freedom to perform the surgery.

A further application of the 3-D tracking and imaging system according to the present invention involves affixing reference transducers anywhere on the patient's head, and several transducers on the tip and shaft of the probe. The transducers can be conventional PZT material, or PVDF. Typically, a minimum of four reference transducers would be placed against the patient's skull, in order to generate an external reference frame. Other reference transducers would be inserted into the brain to provide an internal reference frame.

As the probe is inserted into the head, its movement relative to the reference transducers can be tracked in real time 3-D. The probe will be inserted into the brain, toward the lesion which is visible on a 3-D data set that was previously acquired through CT or MRI. Accordingly, the path of the probe is followed on a computer screen toward the lesion, rather than actually looking at the brain. The lesion itself is located by the position using MRI or CT imaging. The reference transducers affixed to the patient's head can be imaged along with the patient, simplifying the registration process, and since they are affixed to the head, movements of the head relative to the operating table do not pose a problem with respect to tracking. Since the sound path is inside the patient's head, surgeons have complete freedom to move about the patient. As in the catheter guidance system (CGS) described above, the location of the probes is tracked with respect to a reference system. For the head and brain, the most appropriate reference system are 3-D MRI images.

Patients with electrical disturbances of the brain, such as epilepsy, need to have the location of the epilepsy mapped properly prior to surgical intervention. This is done by placing surface electrodes subdurally over the brain. These electrodes are pushed along the brain through small access holes drilled into the skull. However, the location of the electrodes is often difficult to know precisely. Transmitter or receiver transducers are arranged on an electrode pad and on complementary electrode pad located on the outside of the skull. Accordingly, the motion of the electrodes can be tracked in real time, or can be verified with images of the brain taken previously. This greatly simplifies the mapping of brain wave activity anomalies.

The system for carrying out the foregoing procedure would preferably be comprised of the 3-D locating and imaging system described in detail above. Several transducers (PZT or PVDF) are mounted on the surgical probe to be inserted into the brain. Reference transducers are mounted either on the outside of the skull, or slid inside the head, between the brain and the skull. The reference transducers placed on the outside of the patient's head may be taped on or include adhesive backing tape. The reference transducers inserted into the brain will be anchored by sutures, hooks, or simply by friction alone. The patient may be imaged using MRI, CT, or any other multidimensional imaging modality, with the reference transducers in place.

Accordingly, a volume reconstruction of the patient's head would be obtained. The reference transducer may be fitted with components that would enable them to be clearly seen on the 3-D image sets. A physician could then locate the lesion, or plan the surgical approach with respect to these referenced transducers. For example, the

physician could draw a path in 3-D space that would be optimal to follow during the procedures. This path, as well as the intended location of the end point of the procedure, would be recorded by the computer system. The physician could also mark the location of the multiple transducers on the 3-D images, so that the computer system could register the physical location of the transducers to a location in the 3-D image space. It should be appreciated that depending on where the lesion is located in the brain, the surgical probe will be inserted from a different direction. Moreover, it is often necessary to go around critical areas so that minimal damage is done to the brain during insertion of the surgical probe.

The patient would be taken to the operating room with the reference transducers still affixed to the head, and connected to the 3-D locating and imaging system. The surgical probe would then be inserted into the brain, and its location in 3-D space would be instantly displayed within the 3-D volume of the brain, properly registered with the location of the reference transducers. By watching the progression of the surgical probe through the brain, the surgeon would be able to follow a predetermined path towards an intended target.

If the reference transducers are placed on the brain, or implanted within the brain, the path towards a lesion could be tracked even more precisely, since some deformation of the brain is expected upon manipulation of the patient and the insertion of the surgical probes into the brain. Therefore, if the reference transducers detect that their mutual spatial relationship has changed significantly, a coordinate transformation may be implemented, such that the 3-D image set of the brain is

warped to the new geometry, as provided by the reference transducers. The required path towards the lesion can be altered according to this spatial transformation and the surgeon can be confident that the surgical probe is actually progressing towards its intended position. It is because of the expected motion or deformation of the reference transducers, that the internal reference frame is of significant benefit. If a rigid, external reference frame is used, deformation of the brain during surgery could not be detected and the stereotactic probe could very well miss its intended target.

It should be appreciated that the foregoing procedure can be easily integrated with robotic surgery. Therefore, rather than relying on a surgeon to slowly insert the probate, a much more precise robotic arm may be used. Again, the presence of the internal reference frame, and its ability to detect and correct for internal deformations can ensure that the probe is moving along its intended path through the brain, even though the brain tissue in its path may deform.

It should be appreciated that robotic surgery is particularly advantageous where a "steady hand" is required. In this regard, a robotic arm can precisely maneuver along a predetermined path determined by a physician in a 3-D image of the brain. In order to monitor the progress of the robotic arm, a feedback signal may be sent to a control system to make sure that the robotic arm is actually following the intended path.

vi) EMBOLIZATION OF LEAKING BRAIN VESSELS

The 3-D tracking and imaging system described above is also useful during catheter based brain surgery to seal leaking cerebral arteries. Presently, when a

patient has a burst cerebral artery, the vessel needs to be sealed up surgically through open brain surgery, or by plugging it up internally with microcatheters.

Microcatheters are generally .3 mm I.D., .5 mm O.D., with a guide wire inside.

Typically microcatheters take the form of very small plastic tubes that are flexible in

5 bending, but rigid in torsion so that they can be twisted and manipulated. The microcatheters are threaded into the brain under fluoroscopy until they are near the site of the lesion. The catheter is then used to inject a sealant, such as glue (e.g., n-butyl-cyanoacrylate) mixed with a contrast agent, that hardens and embolizes, and then plugs up the micro artery down stream. Other sealants that may be deposited are
10 PVAC sponge (100 - 300 mm dia.), and platinum micro coils (0.010" dia.). The problem with the foregoing procedure is that physicians do not know exactly where the released materials go, and can only track their path using multiple views on fluoroscopy.

The 3-D tracking and imaging system described above dramatically improves
15 the precision for the foregoing procedures. As in the case of brain surgery, a 3-D image set of the cerebral vasculature is obtained and the progression through the vasculature may be monitored by projecting the position of the catheter within the 3-D scene of the vasculature. This may be done by mounting appropriate PZT or PVDF transducers on the catheters and tracking them as described above. The 3-D scene of
20 the cerebral vasculature may be obtained through a CT scan with contrast agent injected into the patient, or with MRI tuned to show moving blood. Similar to the brain surgery procedure described above, transducers are arranged on the catheter and

reference transducers are arranged on the patient's head. It should be noted that the placement of the external reference transducers is dictated by the location of "ultrasound" windows that enable signals to be sent into the skull. Accordingly, the preferred position for the reference transducers are the base of the head near the back, the eye sockets, or under the chin.

The catheters are inserted into the brain initially through an artery near the head, such as the carotid, and maneuvered into the brain. Leaking vessels are located in the brain using contrast and angiography. A contrast agent is injected into the blood stream, and the patient's head is imaged under x-ray fluoroscopy. The presence of the contrast agent makes the arteries into the head visible and the leaks in the brain appear as fuzzy areas of fluid leakage. The 3-D scene of the vasculature is registered with the position of the reference transducers attached to the patient's head. The location and shape of the microcatheter will then be displayed on a computer screen. Accordingly, the physician can interactively steer and advance the catheter through the many branches until it reaches the intended site. The specific sealant used in the procedure can then be released at just the right spot. The principal advantage of the foregoing approach is that the potentially harmful, long-term exposure to X-rays required when using fluoroscopy, can be eliminated.

vii) MEASUREMENT OF CERVICAL DILATION

The onset of labor can be a well controlled process. During the first set of contractions, nurses periodically track the dilation of the cervix. At present this is done by checking the width of the cervix manually. More specifically, one or two

fingers are inserted to feel for the head of the fetus, and estimate the degree of cervical dilation. These dilation measurements are done at regular intervals and a time/dilation curve may be plotted. As a result, the obstetrician can plan the delivery, since the major contractions will come once the rate of cervical dilation increases.

5 The plotting of such dilation curves can be automated and managed for many mothers in the delivery room by measuring the dilation of the cervix with ultrasonic transducers according to the principles of the present invention. Therefore, a maternity ward can be networked so that progress of many mothers going through labor can be monitored remotely by a few nurses at a central station. The obstetrician
10 is thus able to predict which patient is due to deliver at what time, and can plan his or her activities more precisely.

viii) EVALUATION OF KNEE STABILITY

In some orthopaedic procedures, the stability of the knee needs to be evaluated quantitatively during walking. Knee stability can be assessed through manual
15 manipulation; however, only by using a complex imaging technique can the motion of the knee during walking be mapped. By implanting the transducers of the present invention in the knee, the relative motion of the joints can be measured quantitatively during normal gait, and any surgery to augment ligaments can be better planned.

ix) ASSESSMENT OF MYOCARDIAL CONTRACTILITY FOLLOWING 20 SURGERY

Following open heart surgery to repair the myocardium or the coronary arteries, the patient has to be monitored to adjust the levels of drugs that are

administered. This is referred to as "titration" of drugs. The myocardial contractility is measured with a Swan-Ganz catheter and the drug level adjusted to obtain optimal cardiac function. Unfortunately, the Swan-Ganz catheter measures pressure, which is an indirect measure of contractility and can produce inadequate data.

5 However, a pair of transducer according to the present invention provide direct measure of myocardial contractility if attached to the beating ventricle. The transducers can be attached to the myocardium during open chest surgery and can measure the contractility of the heart directly while the chest is open. The leads can then be strung out through the chest wall, and monitoring of myocardial contractility
10 can continue for a few hours or days post operatively. This approach replaces the less precise Swan-Ganz catheter, and can be used to titrate the drugs given to the patient. If the transducers are properly positioned, they can be removed post operatively by pulling on them, in much the same way that pacing electrodes are removed.

x) EYE SURGERY

15 Recently, ultrasonic microscopic imaging has made tremendous progress. Accordingly, it is now possible to obtain 3-D images of the eye using high resolution 3-D ultrasound. For highly precise eye surgery, stereotactic tracking of surgical probes can be done using the 3-D tracking and imaging system of the present invention. Like the brain surgery procedures described above, the movement of the
20 probes can be tracked in real time, and their position displayed within a 3-D image of the organ. In the case of the eye, a high quality 3-D image of the eye may be used to

provide the template through which the probes are to be moved. It should be appreciated that this application is highly suitable for robotic microsurgery.

xi) PROSTATE SURGERY

Prostate surgery may be required when a prostate has become enlarged. This condition can cause such problems as incontinence and impotence. In many cases, the enlarged prostate is caused by a tumor. The tumor will need to be destroyed or removed, otherwise it may spread and kill the patient.

As in the case of eye surgery, 3-D ultrasound is useful in the diagnosis of prostate tumors. 3-D ultrasound may be used to visualize the size and shape of the prostate and may also be used to aid in stereotactic surgery of the prostate. However, it should be noted that 3-D ultrasound typically gives poor quality images and does not provide real time position feedback. Accordingly, there is a need to track the position of the surgical probes in real time using some other modality. The approach used in connection with the prostate and other internal organs would be essentially the same as the approach used in connection with the eye. In this respect, the organ of interest would be imaged using 3-D ultrasound, and the probes visualized with the 3-D tracking and imaging system of the present invention, as the probes are manipulated through the organ. The region to be treated is initially determined using an x-ray or ultrasound.

The probes are inserted through the urethra, or through skin below the penis. Since it takes several minutes to obtain a new 3-D image, the 3-D scene can be periodically updated to show the progress of the surgery. Transducers are placed at

several sections along the length of the probe, to provide accurate tracking of the probe location. Reference transducers are placed on the patient's body at locations that enable them to communicate with the transducers mounted to the probe.

Therefore, the reference transducers need to be in locations that surround the area of interest, and also have appropriate ultrasound "windows" through which the sound can pass. Accordingly, bones and air pockets may not be in the way.

xii) TRACKING OF TMR CATHETERS

TMR is an acronym for Trans-Myocardial Revascularization. This procedure involves the "drilling" of holes through the myocardium wall to improve circulation through the tissue. When coronary arteries become blocked with atherosclerotic plaque, the heart muscle downstream receive less blood than necessary and becomes ischemic. The traditional surgical approach to this problem is coronary artery bypass. A novel approach to revascularizing ischemic myocardium, without the lengthy and potentially complicated coronary bypass procedure, is to use TMR. The conventional approach to TMR is to expose the heart through a chest incision and drill holes through the muscle from the outside in, all the way into the ventricular chamber. This is done using a fiber optic light guide, (about 1 to 2 millimeters in diameter) that carries laser light energy. The fiber guide is placed against the heart, perpendicular to the surface and pushed into the heart as the laser is fired. The laser drills a channel ahead of it as the light guide is pushed through the muscle. Once the hole has been drilled, blood very briefly squirts out through the hole, but the outer portion of the hole quickly seals with clot and physically contracts as the heart muscle beats. During

a typical procedure, the surgeon would drill a dozen or more holes through the myocardium in the ischemic area. The benefit to the patient is almost immediate, and continues for many months afterwards.

While it is not clear exactly how and why the procedure works, it is speculated
5 that in the short term, the holes created allow blood to percolate through the muscle in some way, while in the long term, the injury created stimulates angiogenesis, or the growing of new collateral capillaries and arterioles.

The obvious disadvantage of the conventional approach to TMR is the need to expose the heart. A preferred method would be to use a catheter based approach that
10 would drill the holes from the inside out. Such a procedure, however, requires proper guidance and visualization of the catheter within the heart. The 3-D tracking and imaging system of the present invention is well suited to this medical procedure. The TMR catheters may be fitted with ultrasonic transducers in much the same way as electrophysiology catheters.

15 Since the laser energy must be applied to the tissue directly, and cannot be passed through the blood, the light guide must be in contact with the tissue before the laser is fired. The required TMR catheter can therefore be fitted with a solid state (MEMS) force transducers that can measure the applied tip force against the catheter in 3 axes. The tip of the catheter may also be fitted with an ultrasonic transducer to
20 look forward and determine to what depth the catheter has been passed through the muscle, and if it is about to come out the other side of the ventricle.

xiii) A 3-D ENVIRONMENT WITH 2-D ECHO PLANES PRESENTED WITHIN

A large number of diagnostic and surgical procedures are performed with the assistance of conventional 2-D echo imaging techniques. In this respect, the physician manipulates a surgical instrument (e.g., a probe or catheter) inside the patient's body, and at the same time tilts the imaging head of the echo machine until the ultrasound
5 beam transects the instrument and the instrument becomes visible on a display monitor. Very often, the instruments are located after considerable "hunting", and the process itself is quite cumbersome. This procedure is often used in the case of amniocentesis and biopsies. In each case, needle or "biting" tools are inserted under ultrasound imaging guidance. In the case of amniocentesis, a physician inserts a
10 needle through the abdomen into the uterus, while at the same time an assistant holds the ultrasound probe steady, making sure that it transects the amniocentesis needle, so that the needle can be visualized.

It would be advantageous to use a virtual 3-D environment that can be visualized on the display monitor of a suitable 3-D graphics computer, according to
15 the present invention. In this regard, several reference transducers are placed on the back and abdomen of the patient, and a simple coordinate system is generated on the computer monitor, showing the direction towards the head and feet, the left and right sides of the patient, and the front and back. Initially, this would appear as an empty box with simple graphics or arrows, as well as the surface transducers shown
20 graphically. When an amniocentesis needle is inserted into the abdomen, one or more ultrasonic transducers mounted along the needle shaft are tracked and displayed within the 3-D environment as simple graphical elements. This 3-D scene can be

visualized from any viewpoint by simply moving the mouse and rotating the visual scene on the computer.

A preferred embodiment of an echo imaging system according to the present invention will now be described with reference to Figs. 17A, 17B and 18. A typical
5 echo machine ultrasound imaging head 1700 has a plastic hand held component with a cable 1710 that connects to a main unit (not shown). Imaging heading 1700 has a window through which ultrasound is transmitted and received by an image transducer 1702. The ultrasound imaging head 1700 is fitted with a transducer housing 1704 which clips to imaging head 1700. An exploded view is shown in Fig. 17B.

10 Transducer housing 1704 holds three or more position transducers 1706 that form a plane perpendicular to the imaging beam. Thus, position transducers 1706 reside between the imaging head 1700 and the skin that imaging head 1700 contacts. It should be appreciated that while four position transducers 1706 are shown in Figs. 17A and 17B, only three position transducers 1706 are need to measure all angles.
15 Reference transducers (not shown) are mounted to the patient's skin (e.g., back and abdomen). As the imaging head 1700 is tilted and angulated while pressed against the abdomen, the coordinates of position transducers 1706 define a plane that is perpendicular to the ultrasound imaging beam. It should be noted that transducer housing 1704 makes contact with the abdomen. Once the position and orientation of
20 the imaging plane is known in 3-D space relative to the coordinate system of the patient, the typical pie-shaped sector scan produced by the ultrasound imaging head can be inserted into the 3-D scene of the patient. The 3-D scene will therefore contain

a perspective rendering of the patient frame of reference, the location and direction of the surgical instrument (e.g., amniocentesis needle), and the pie-shaped, ultrasound sector image, properly oriented within this scene, as shown in Fig. 18.

The ultrasound image may be shown in real time in perspective by texture-mapping the video signal onto a pie-shaped polygon drawn in the 3-D scene. Current generation graphics computers enable this type of real-time image transformation. It should be noted that the location of all of the transducers with respect to each other can be determined, in the manner described above. Accordingly, one of the transducer locations is chosen as the origin, another as the x axis, and a third as the y axis, and a fourth as the z axis. The coordinates system may be defined by the user. The orientation of the imaging plane is calculated from the angle of the four imaging head transducers 1706, and the coordinate system defined by the reference transducers mounted to the patient's body.

By visualizing the location of the imaging plane relative to the inserted surgical instrument, the imaging head 1700 can be more quickly manipulated and angled until it transects the surgical instrument (e.g., amniocentesis needle). The shadow of the surgical instrument then becomes visible in the texture mapped, real time ultrasound image, and the surgical instrument graphic can be shown piercing the ultrasound image where its shadow is visible. Accordingly, a physician can immediately determine in which direction to angulate imaging head 1700 or move the surgical instrument to get proper orientation within the visual scene. Accordingly, the foregoing procedure is thus safer, faster and more precise than prior art procedures.

The foregoing description provides specific embodiments of the present invention. It should be appreciated that these embodiments are described for purposes of illustration only, and that numerous alterations and modifications may be practiced by those skilled in the art without departing from the spirit and scope of the invention.

5 For instance, it should be appreciated that the transducers may use the time of flight, or phase differences as a means of determining position. Moreover, the transducers may take the form of ultrasonic transducers or electromagnetic transducers. It is intended that all such modifications and alterations be included insofar as they come within the scope of the invention as claimed or the equivalents thereof.

The invention claimed is:

1. A method of performing an in vivo medical procedure on an associated body using a 3-D tracking and imaging system, said method comprising:

mounting a plurality of mobile transducer means to an instrument
5 means;

mounting one or more reference transducers means to locations on the body, the reference transducer means having a position fixed relative to the body;

generating three-dimensional coordinates of the mobile transducer means relative to a reference frame established by the reference transducer means;

10 generating image data of the environment surrounding the instrument means to provide an image template; and

registering the three-dimensional coordinates with the image data to form a 3-D image scene showing the position of the mobile transducer means
15 relative to the image template.

2. The method as defined in claim 1, wherein the body is a human body.

3. The method as defined in claim 2, wherein the medical procedure is the removal of an obstruction from the circulatory system, and said instrument is one of

the following: a standard catheter, an intravascular ultrasound imaging catheter, a balloon catheter and a stent deployment catheter.

4. The method as defined in claim 2, wherein the medical procedure is a biopsy, and said instrument is at least one of a biopsy catheter and a biopsy needle.

5. The method as defined in claim 2, wherein the medical procedure is amniocentesis, and said instrument is an amniocentesis needle.

6. The method as defined in claim 2, wherein said medical procedure is stereotactic brain surgery, and said instrument is a surgical probe.

7. The method as defined in claim 6, wherein said method further comprises: warping said image data in response to the changes in the position of said reference transducer means.

8. The method as defined in claim 7, wherein said method further comprises: guiding a robotic arm in accordance with a path established in the 3-D image scene.

9. The method as defined in claim 2, wherein said medical procedure is brain surgery to seal leaking cerebral arteries, and said instrument is a catheter.

10. The method as defined in claim 2, wherein said medical procedure is measurement of cervical dilation.

11. The method as defined in claim 2, wherein said medical procedure is evaluation of knee stability.

12. The method as defined in claim 2, wherein said medical procedure is assessment of myocardial contractibility, said mobile transducer means mounted to the myocardium.

13. The method as defined in claim 2, wherein said medical procedure is eye surgery.

14. The method as defined in claim 2, wherein said medical procedure is prostate surgery, and said instrument is a medical probe moved through the prostate.

15. The method as defined in claim 2, wherein said medical procedure is trans-myocardial revascularization (TMR), and said instrument is a TMR catheter moved through the heart.

16. A method for carrying out a medical procedure by displaying a 3-D image scene having 2-D echo planes presented therein, the method comprising:

mounting a plurality of mobile transducer means to an instrument having an ultrasound image transducer means for generating a 2-dimensional echo image plane;

mounting a first reference transducer means to a first fixed location;

mounting a second reference transducer means to a second fixed location;

generating three-dimensional coordinates of the mobile transducer means relative to a reference frame established by the first and second reference transducer means;

registering the 2-dimensional echo image plane with the three-dimensional coordinates; and,

displaying the 2-dimensional echo image plane at the three-dimensional coordinates, in relation to the reference frame established by the first and second reference transducer means.

17. The method as defined in claim 16, wherein said first fixed location is a patient's back, and said second fixed location is a patient's abdomen.

18. A method according to claim 1, wherein the locations on the body for mounting the reference transducer means are internal to the body.

19. A method according to claim 1, wherein said method further comprises the step of:

ablating a portion of the bodily structure when the instrument means has been positioned at a location in a bodily structure where ablation is desired.

20. A method as defined in claim 19, wherein the instrument means is a catheter.

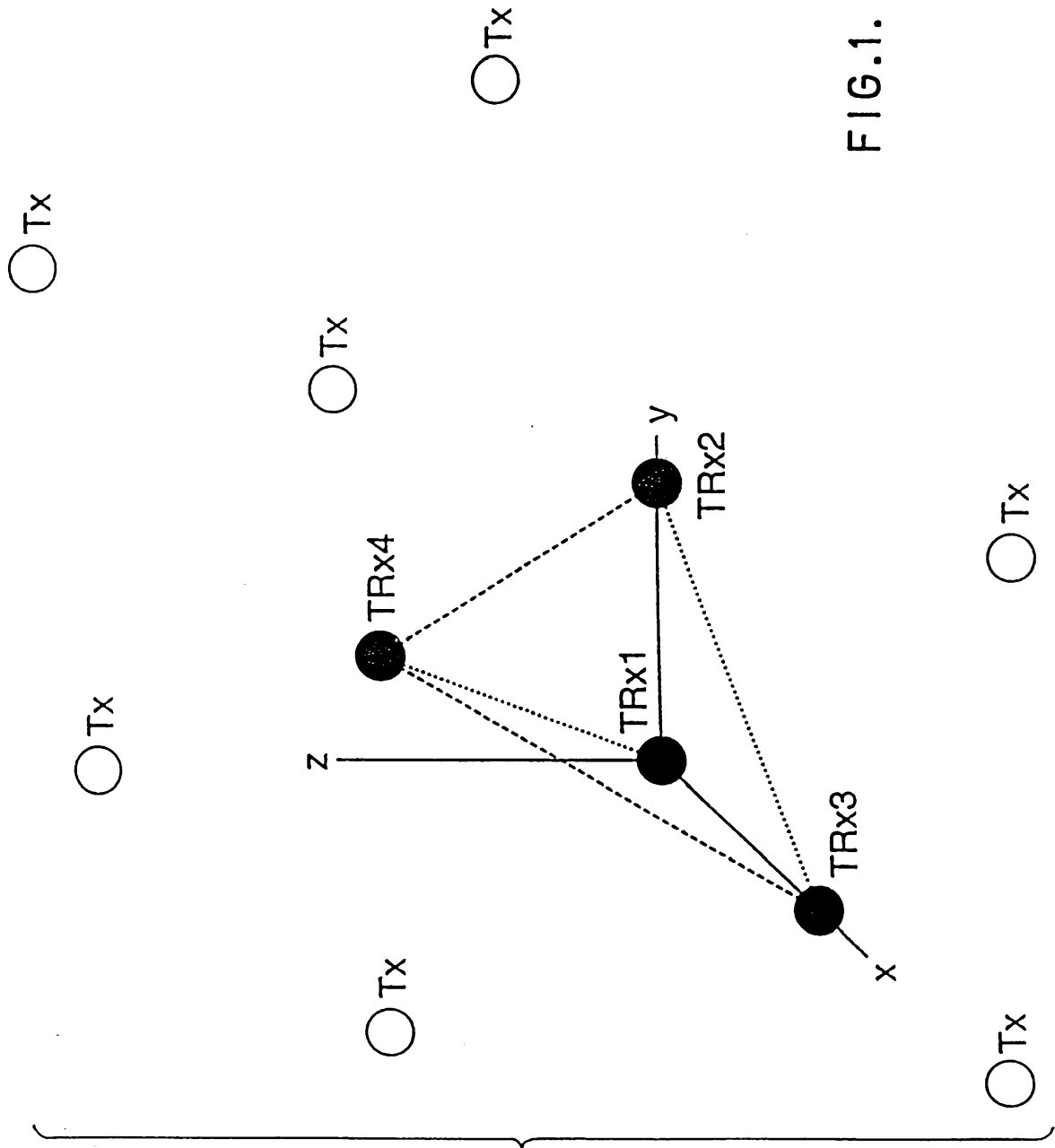

FIG.1.

FIG.2A.	FIG.2C.
FIG.2B.	FIG.2D.

FIG.2.

	FIG.3A.	FIG.3B.	FIG.3C.
FIG.3D.	FIG.3E.	FIG.3F.	FIG.3G.
FIG.3H.	FIG.3I.	FIG.3J.	FIG.3K.
FIG.3L.	FIG.3M.	FIG.3N.	
FIG.3O.	FIG.3P.	FIG.3Q.	

FIG.3.

FIG.4A.	FIG.4B.	FIG.4C.	FIG.4D.
FIG.4E.	FIG.4F.	FIG.4G.	FIG.4H.
FIG.4I.	FIG.4J.	FIG.4K.	FIG.4L.
FIG.4M.	FIG.4N.	FIG.4O.	FIG.4P.

FIG.4.

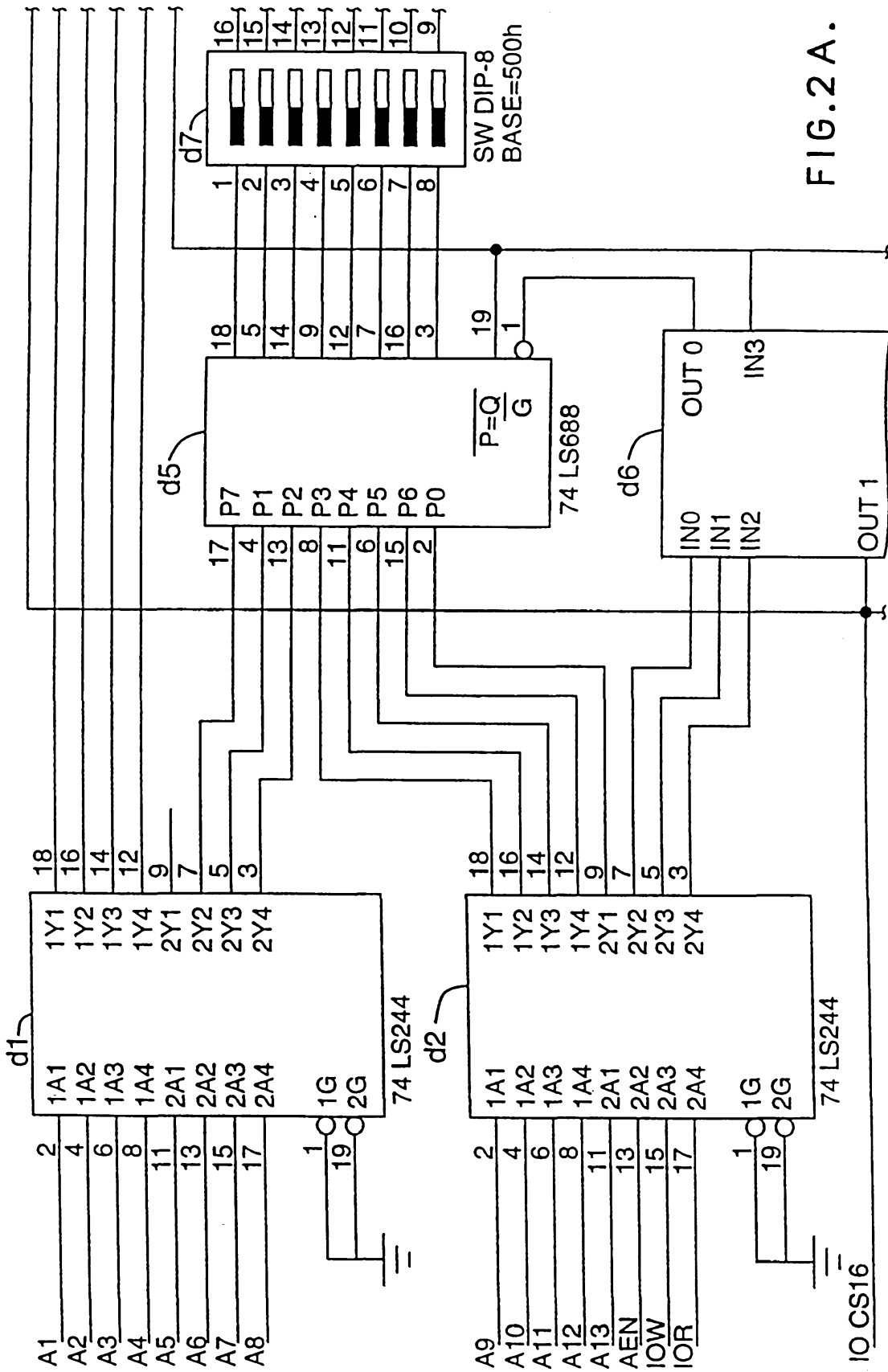

FIG. 2 A.

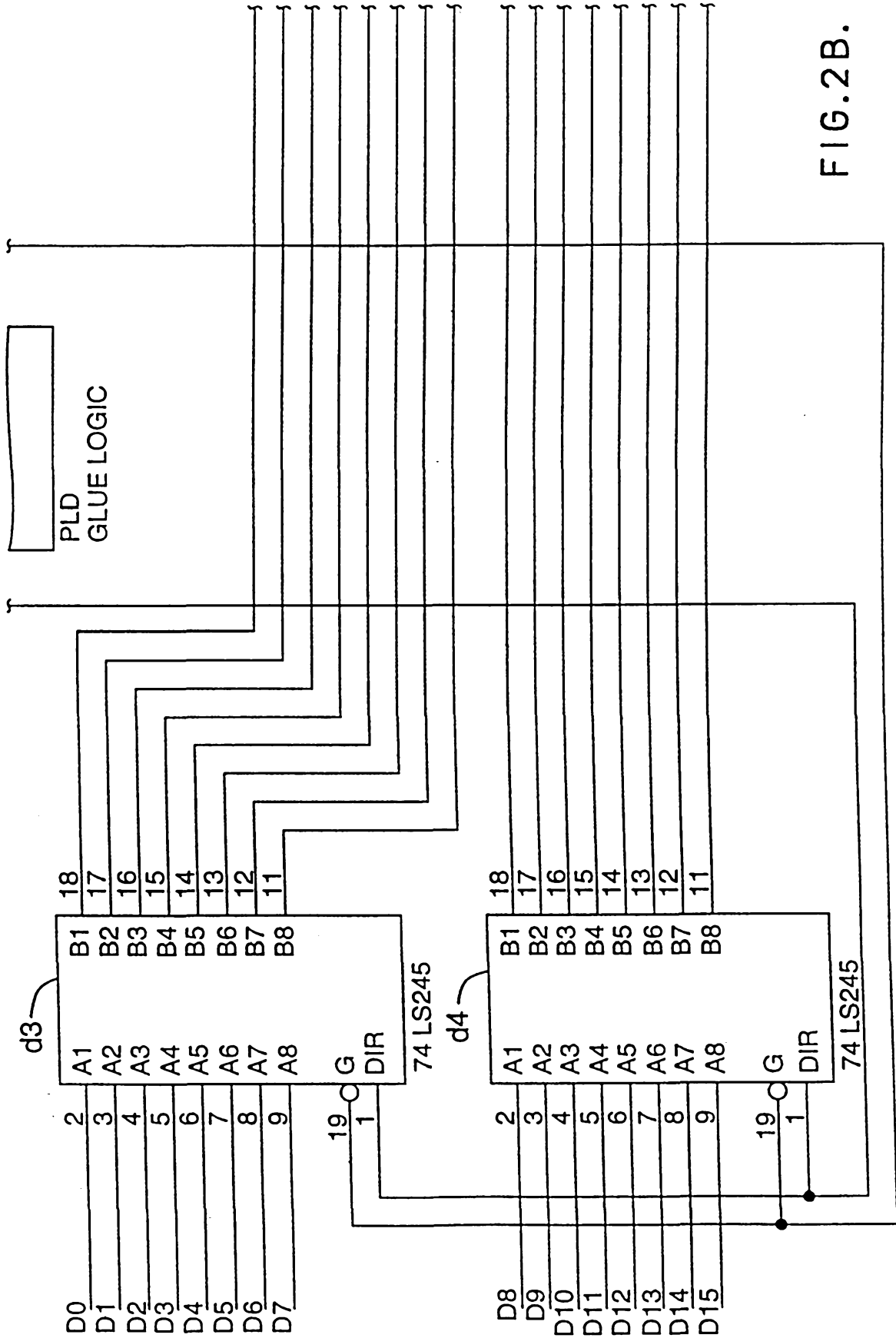
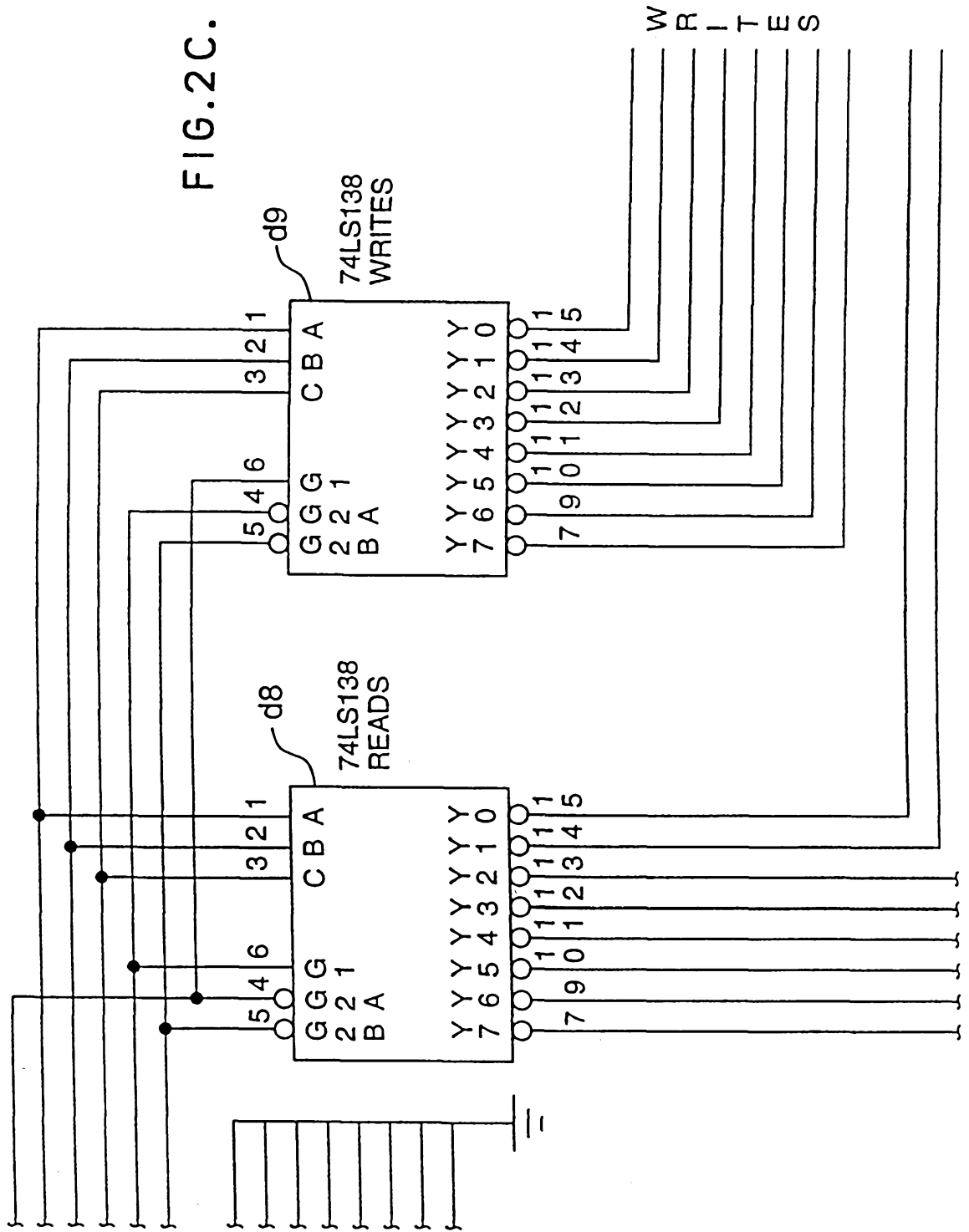

FIG.2B.

FIG. 2C.



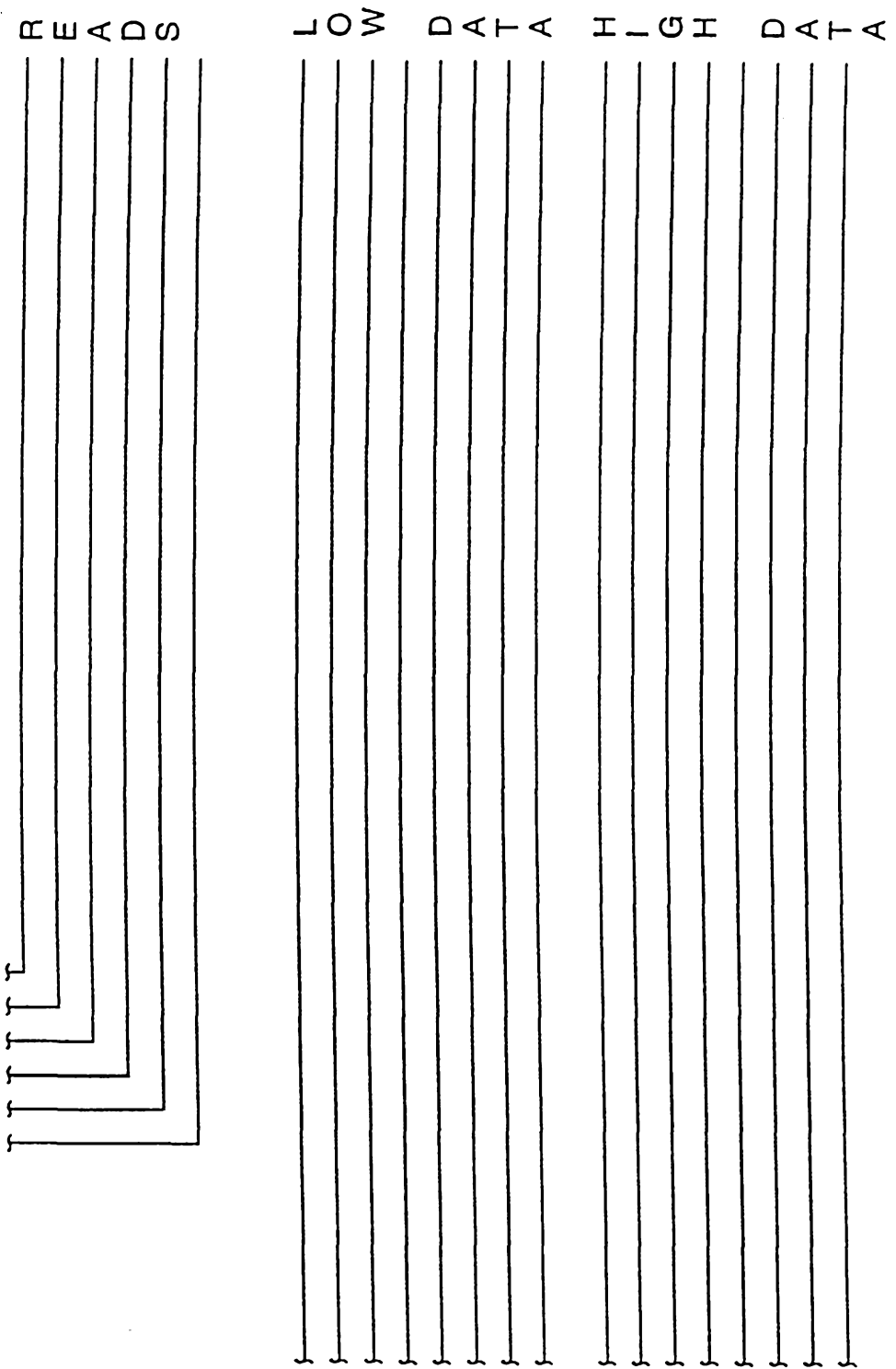

FIG.2D.

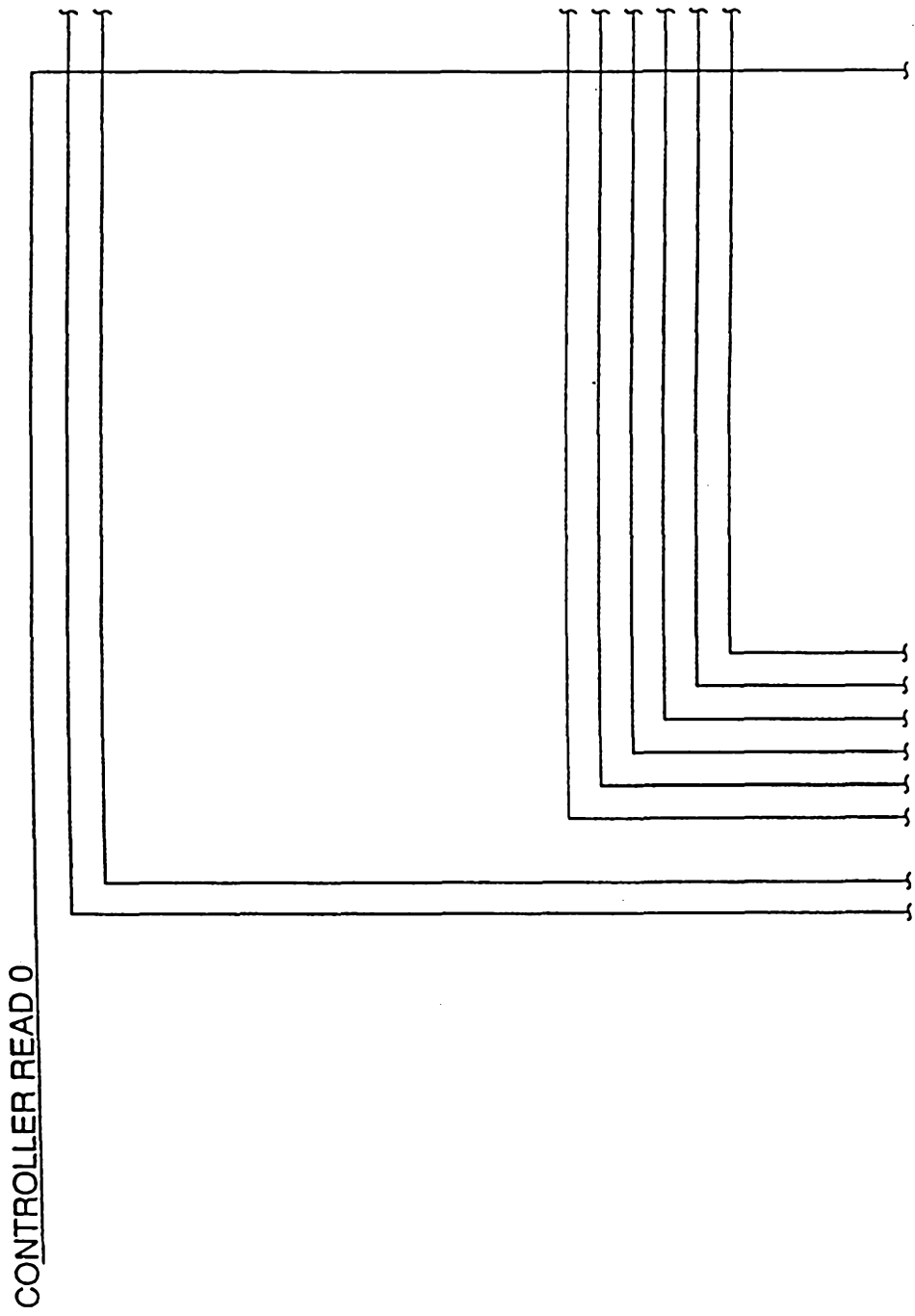

FIG. 3A.

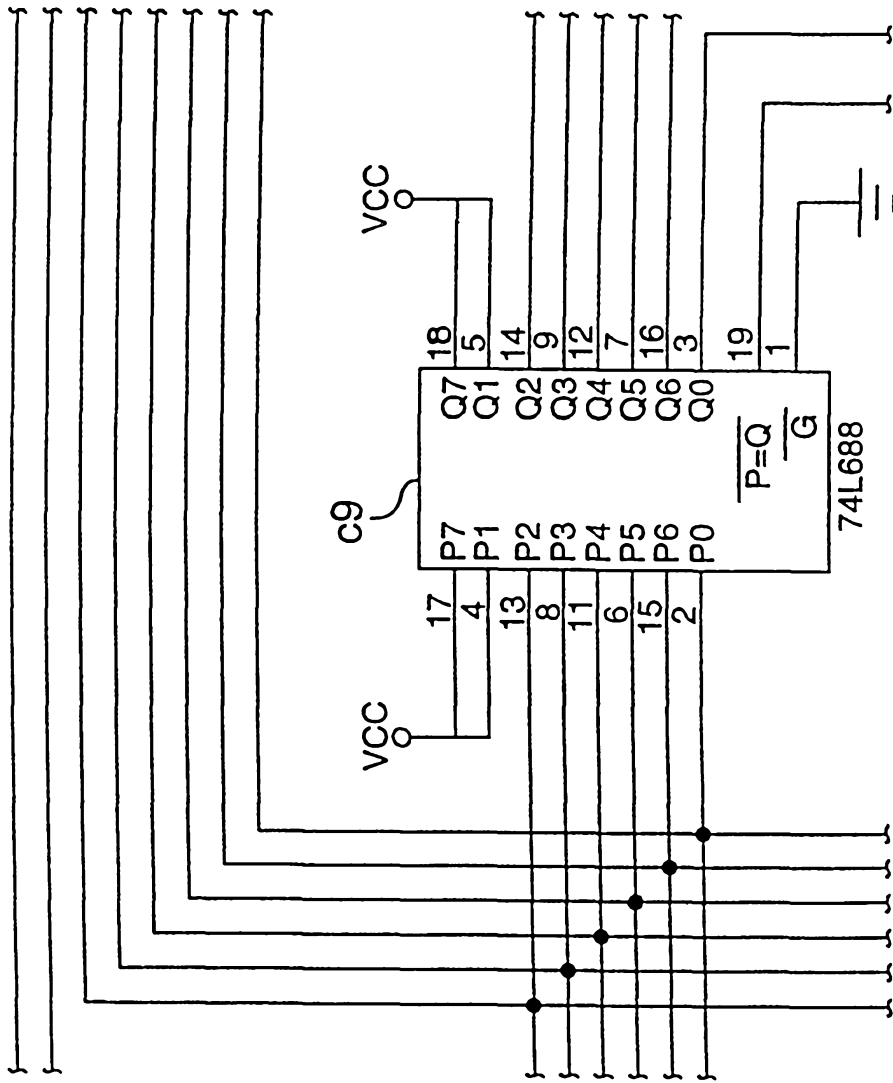

FIG.3B.

9/70

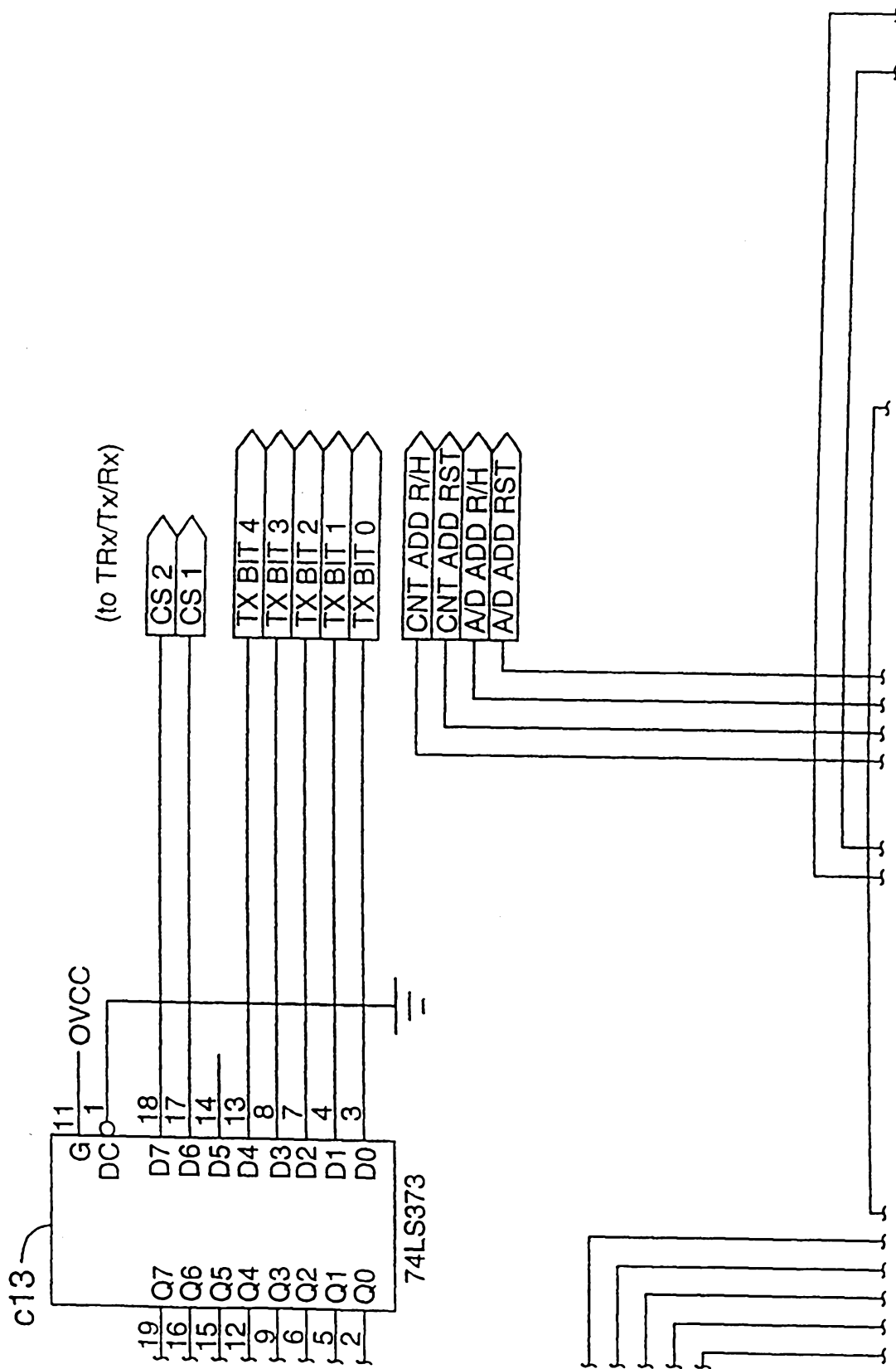

FIG.3C.

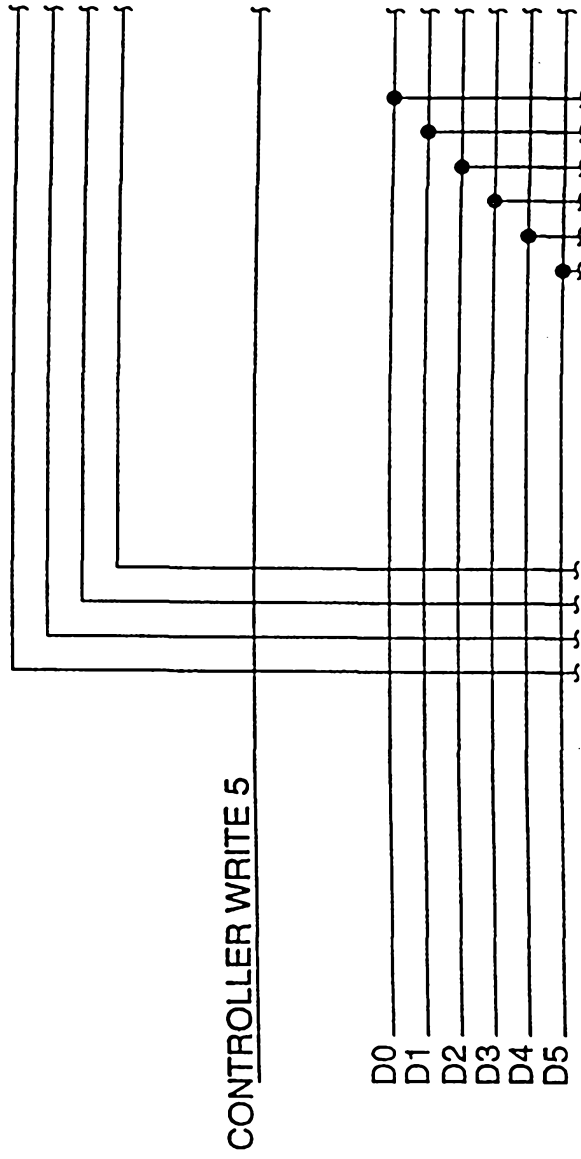

FIG.3D.

11/70

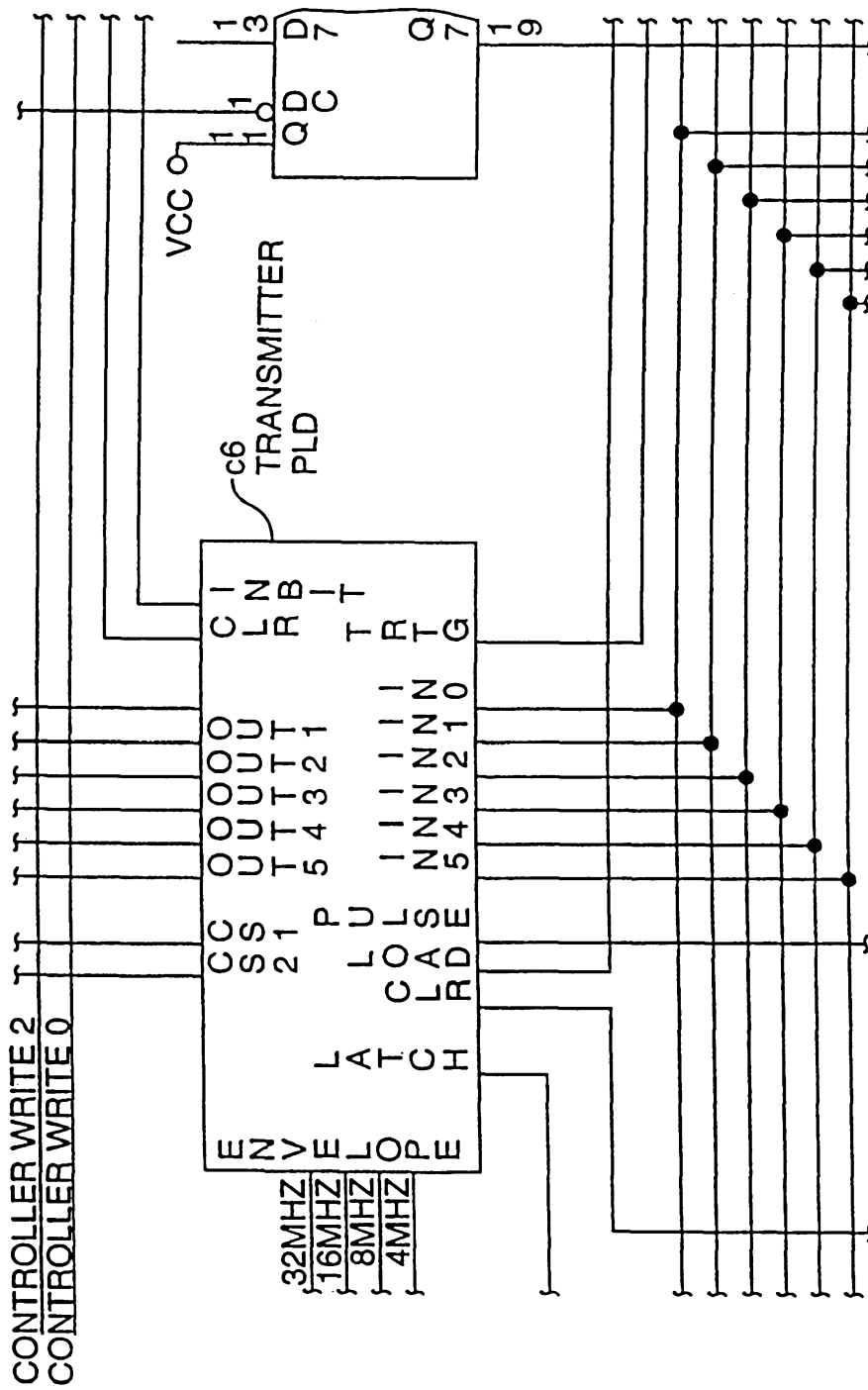

FIG.3E.

12/70

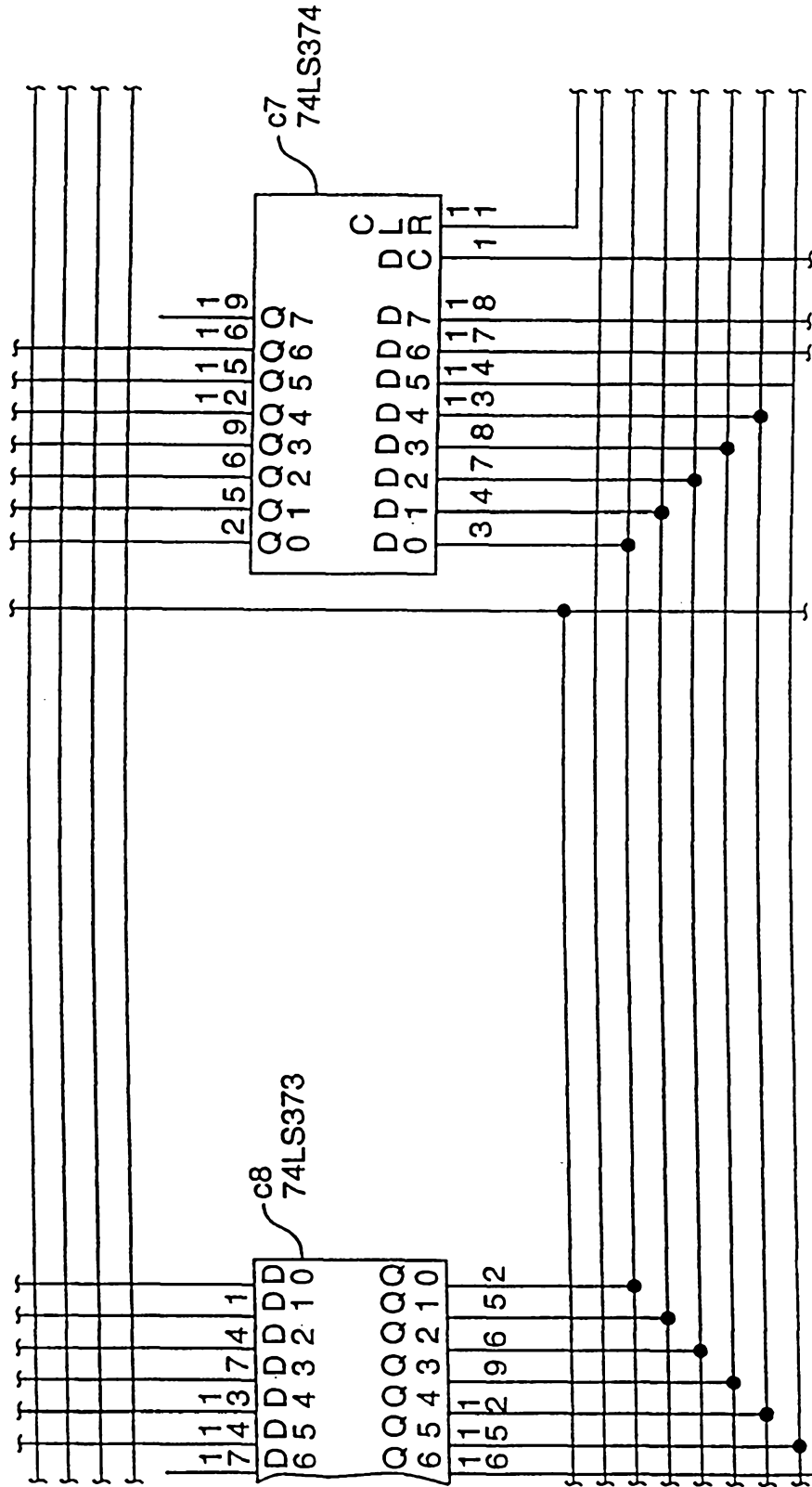

FIG.3F.

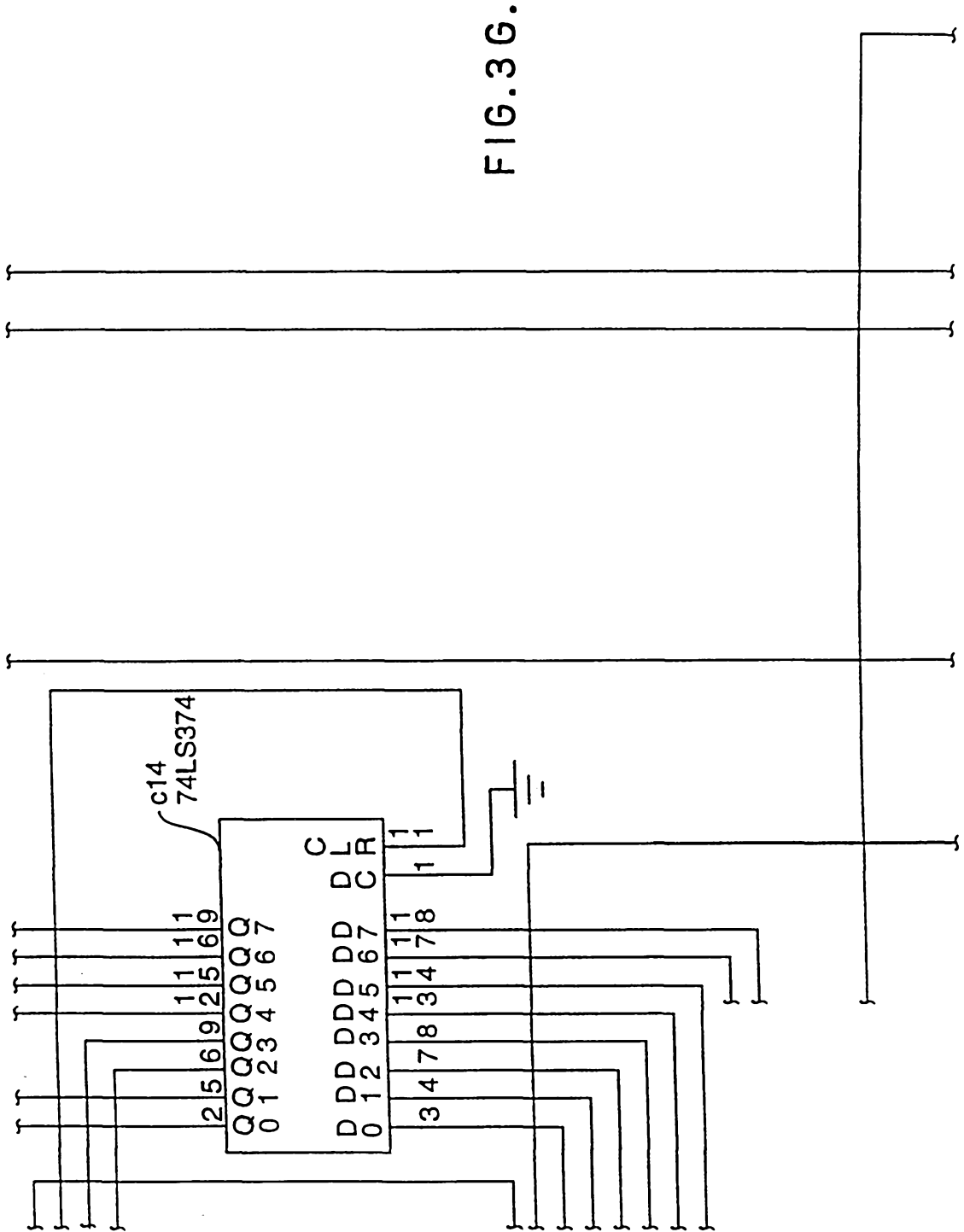

FIG. 3G.

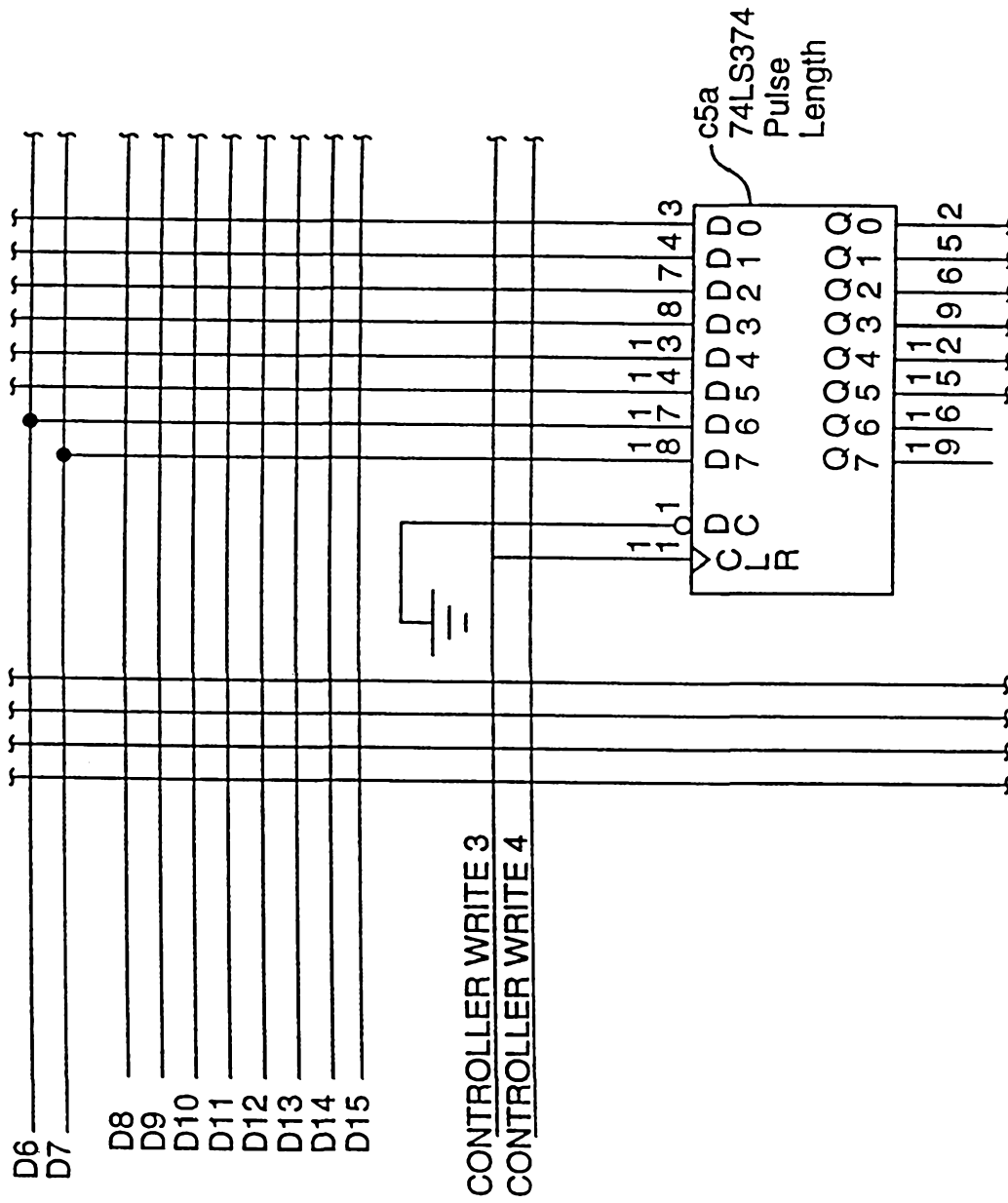

FIG. 3H.

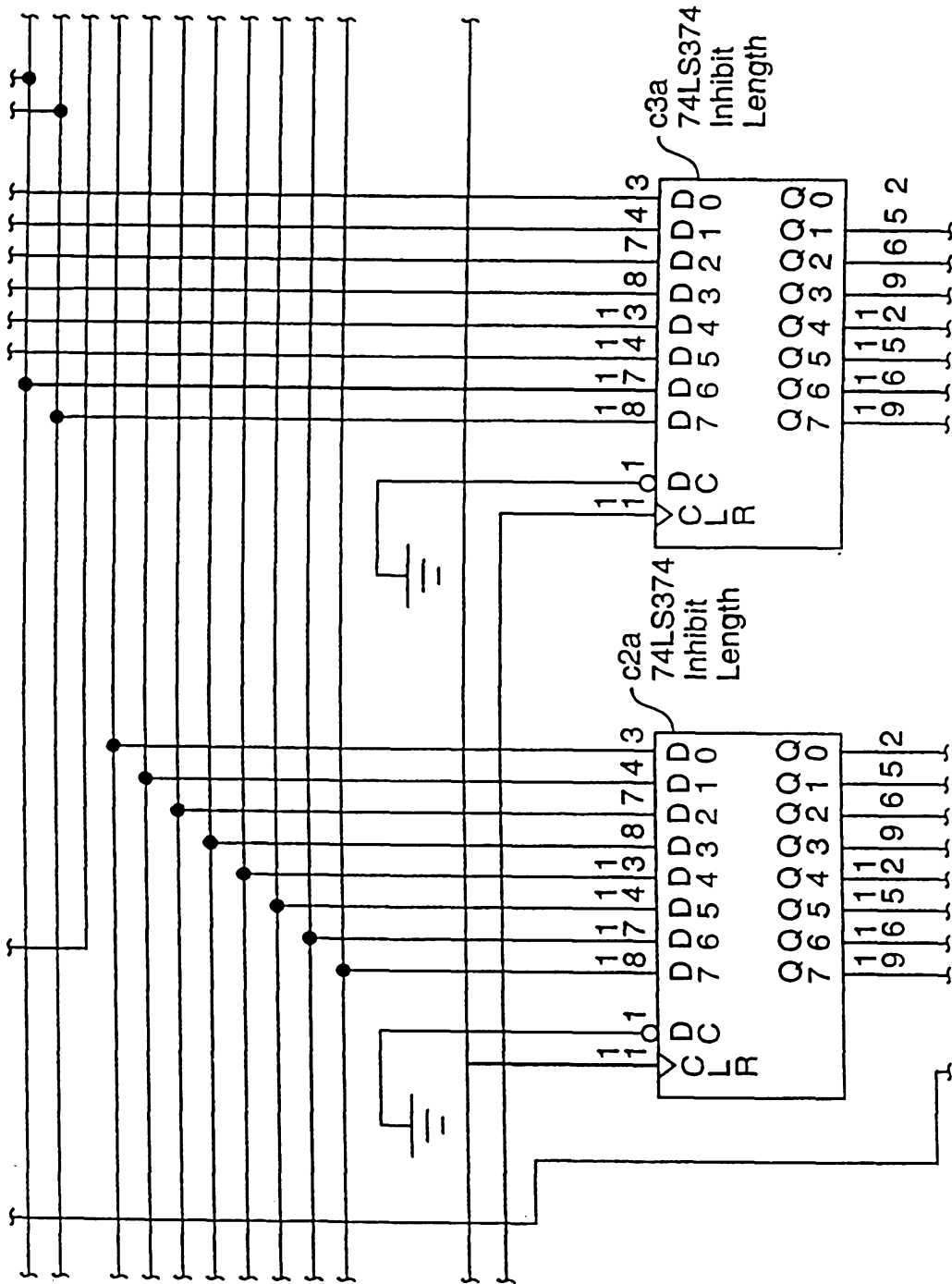

FIG. 3I.

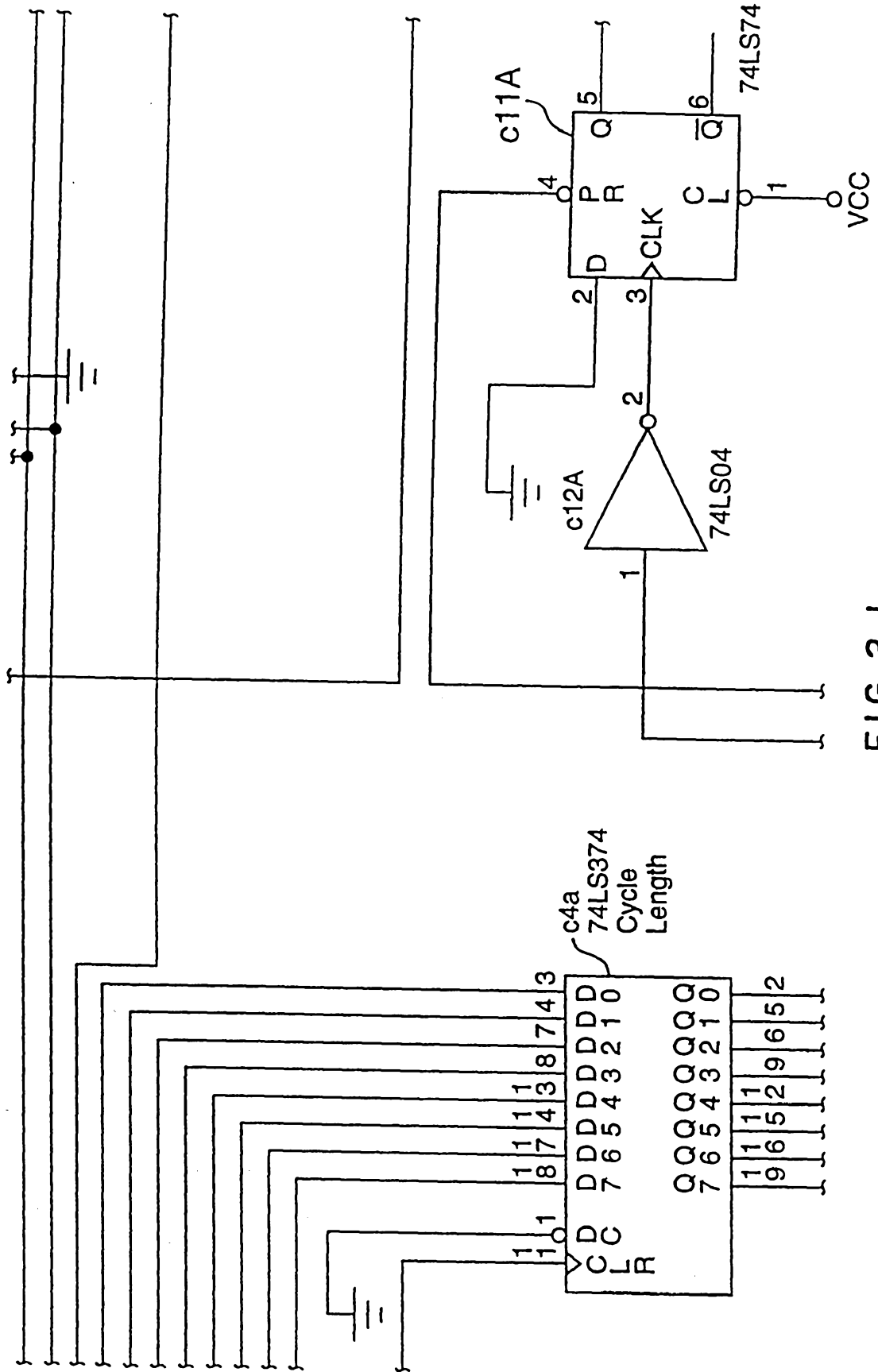
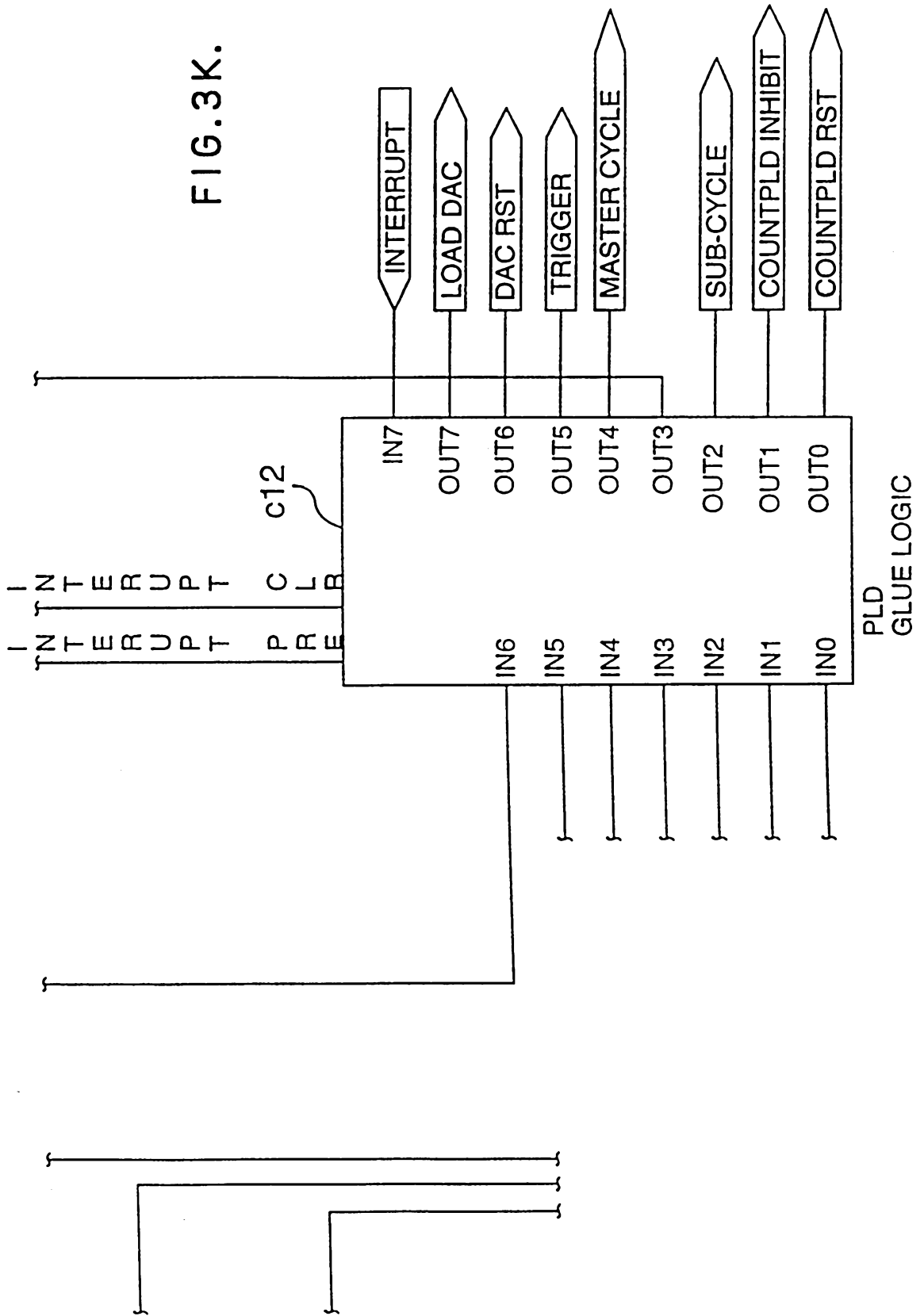

FIG. 3J.

FIG. 3K.



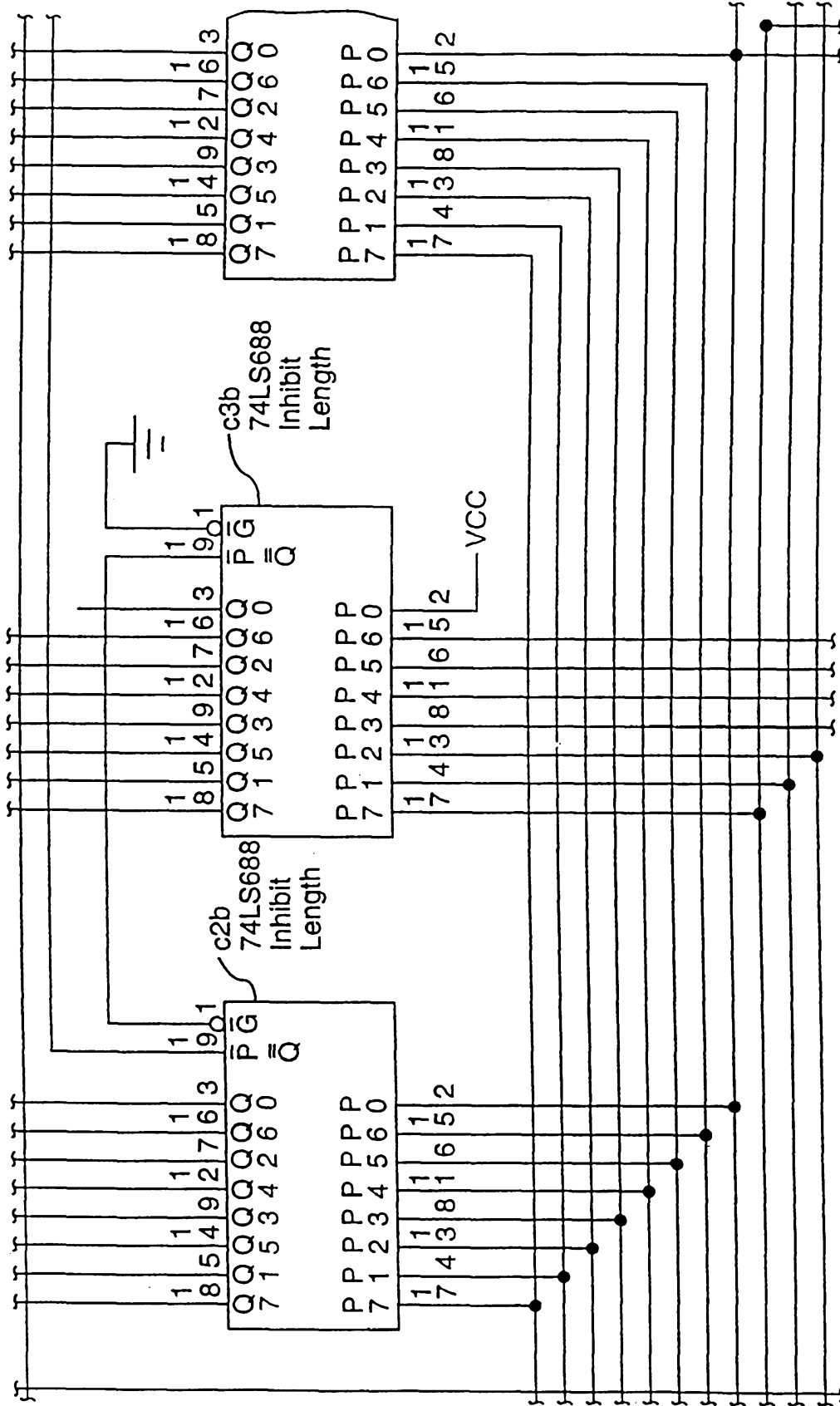

FIG.3M.

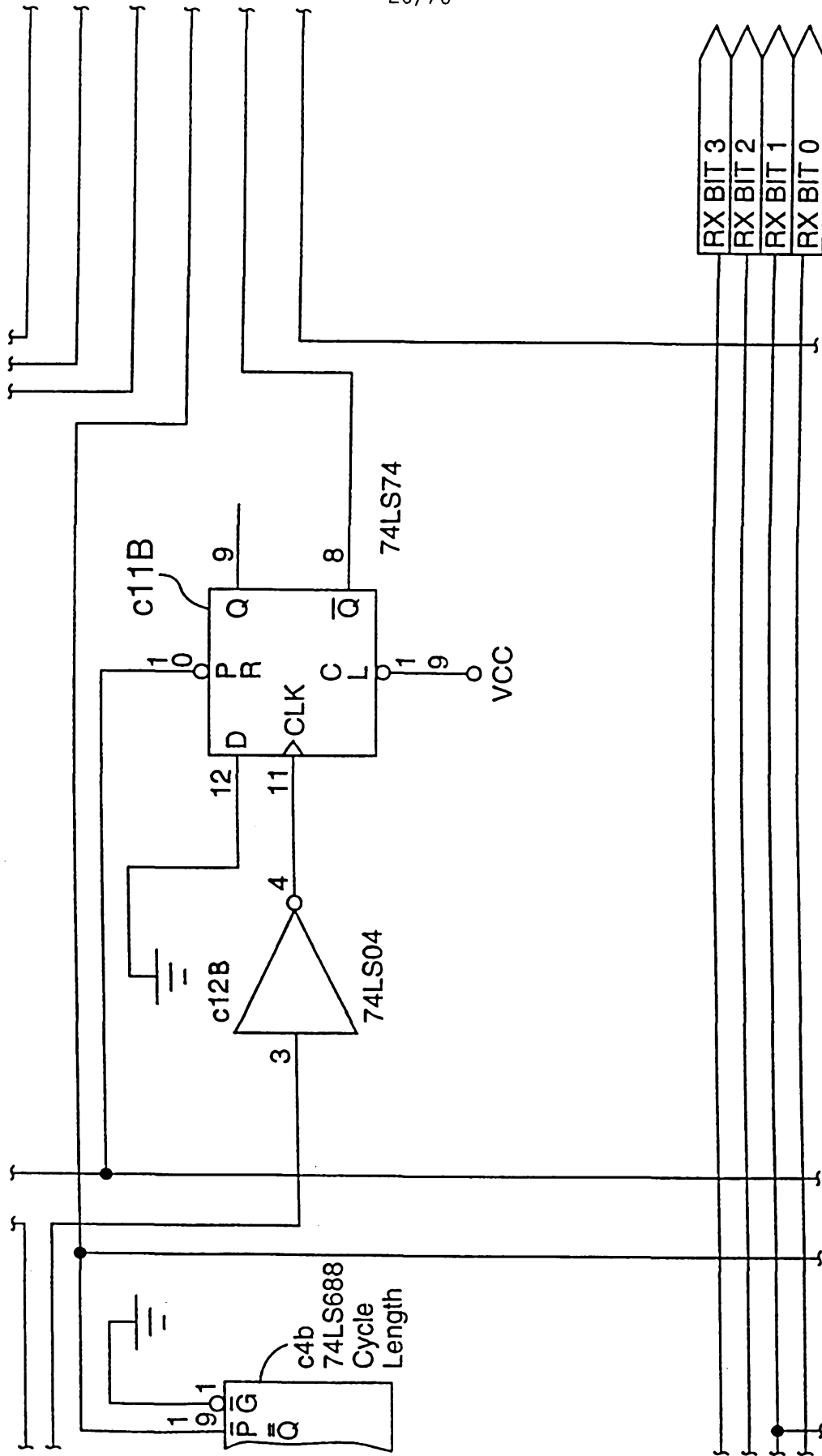

FIG. 3N.

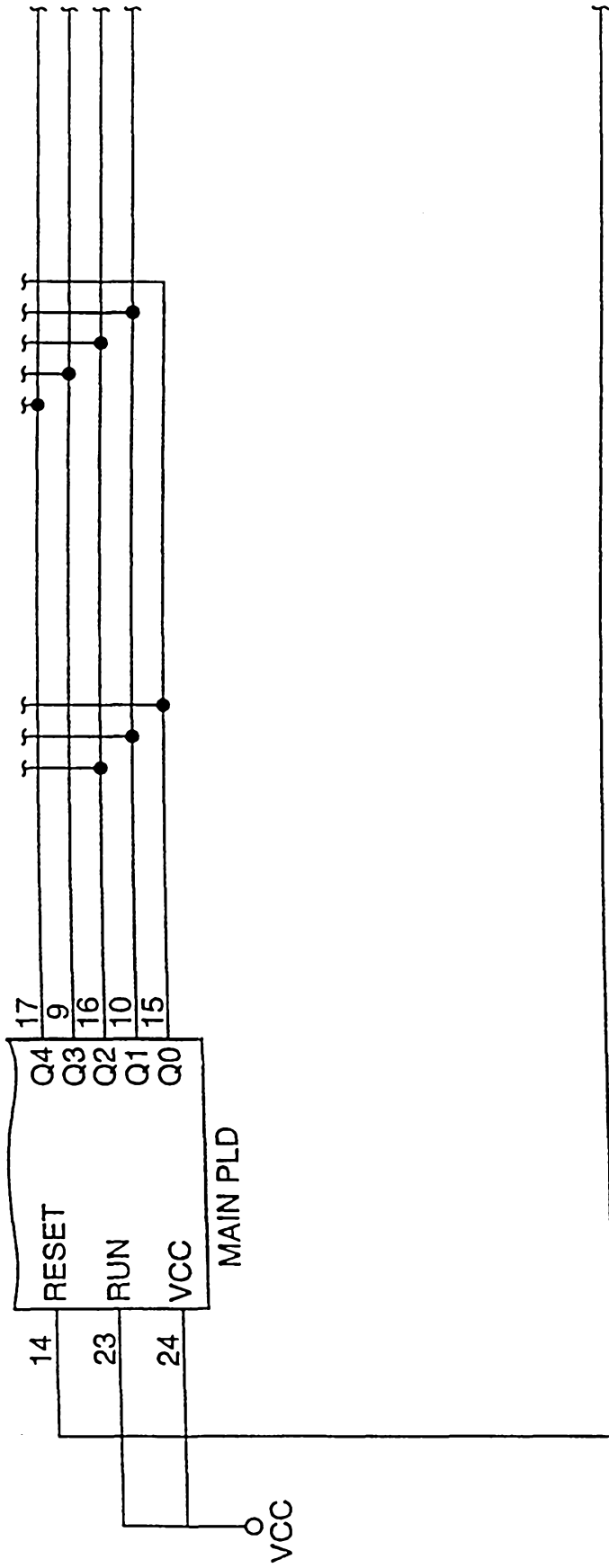

FIG.30.

22/70

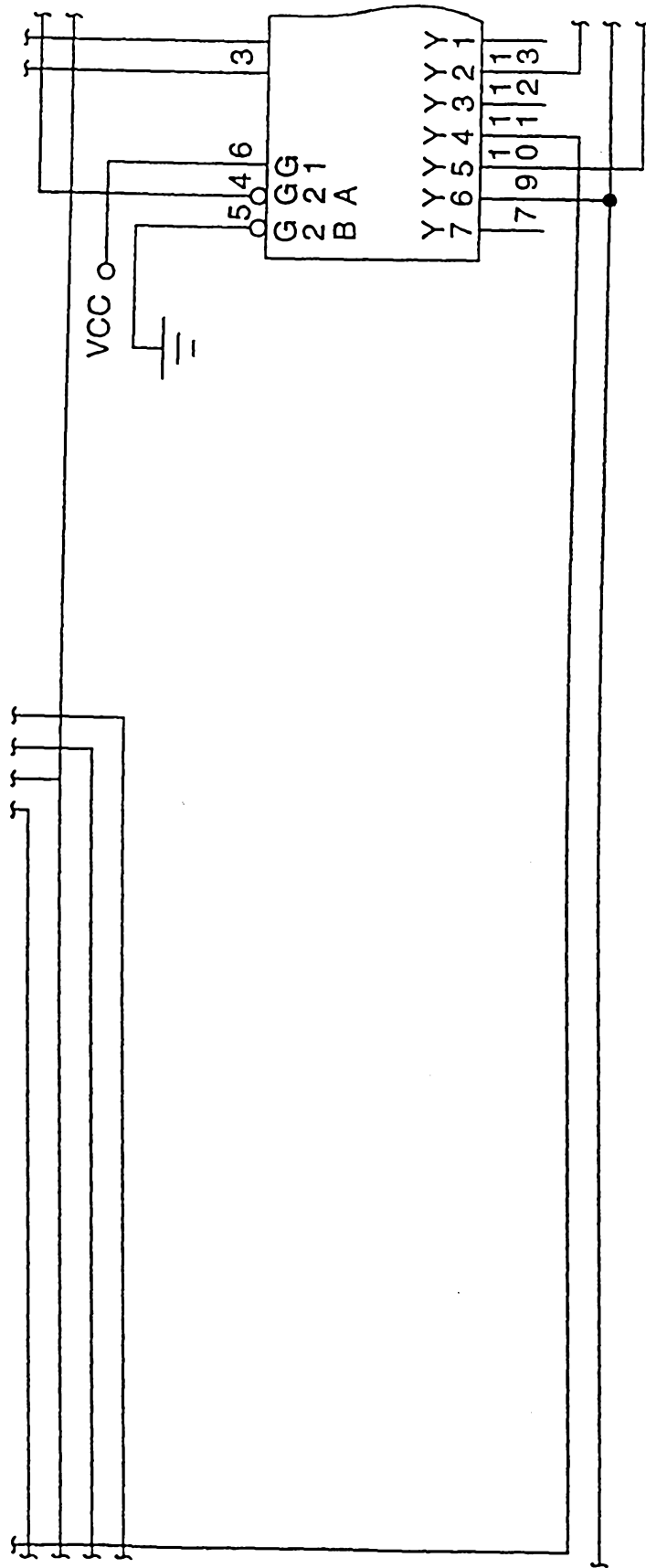

FIG.3P.

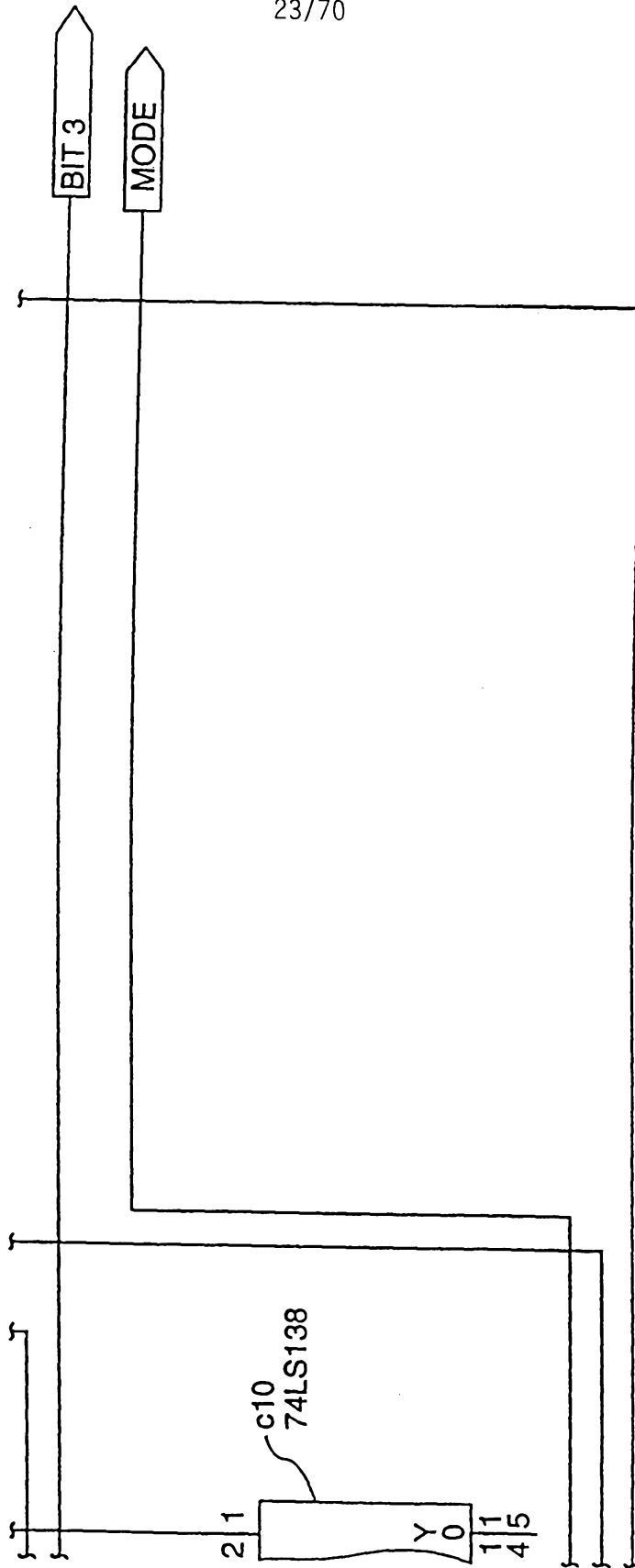

FIG.3Q.

FIG.4A.

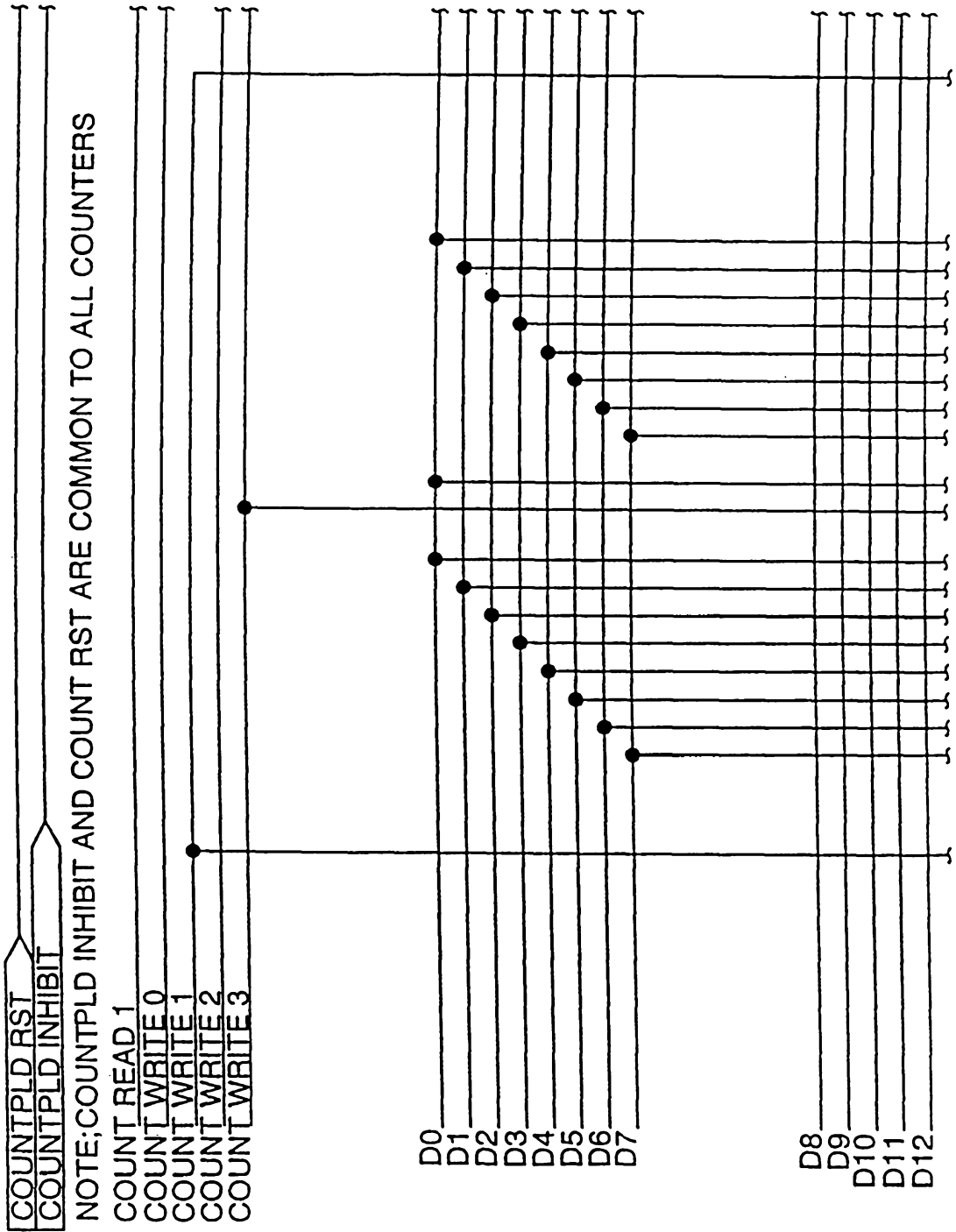
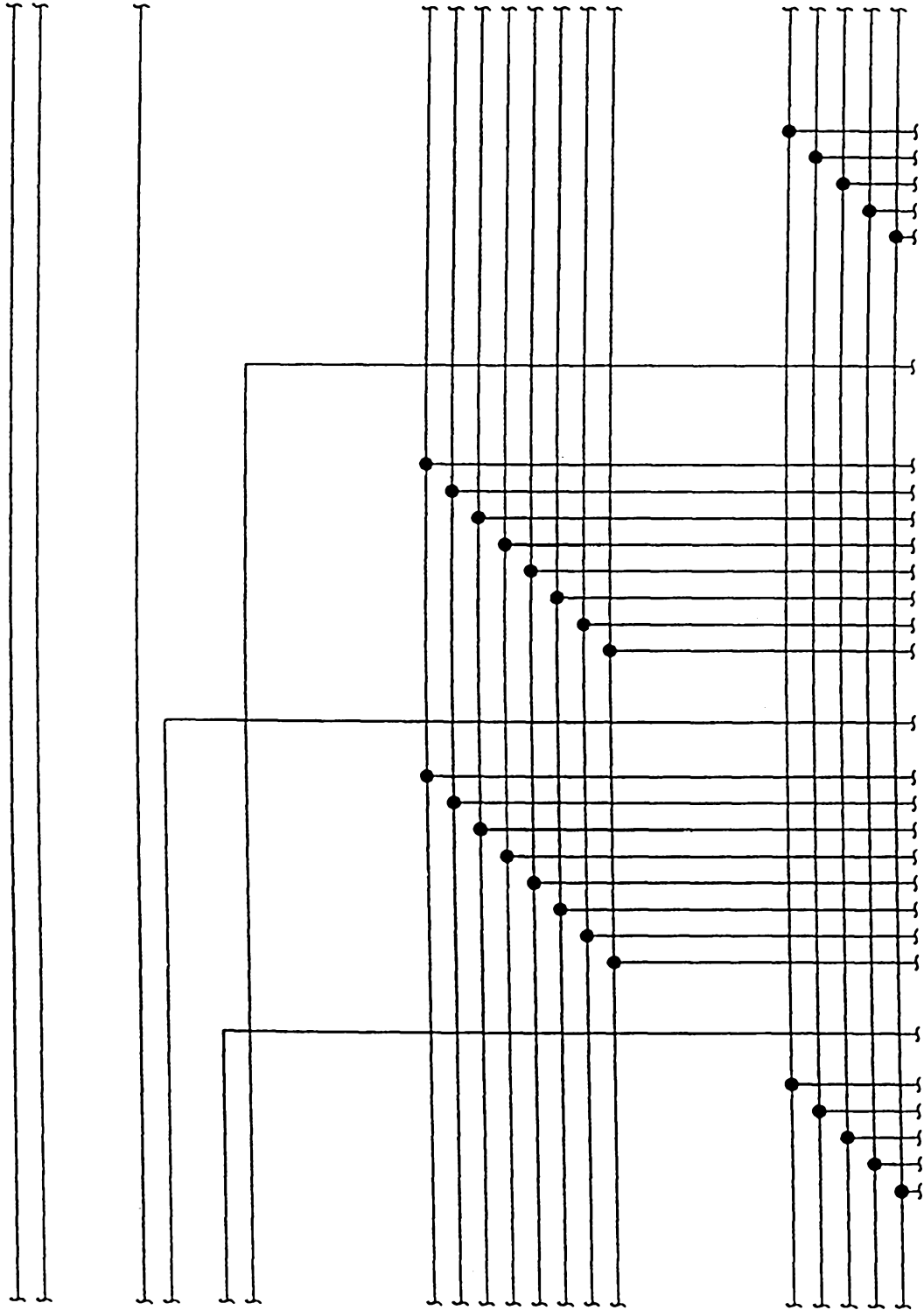

FIG. 4B.



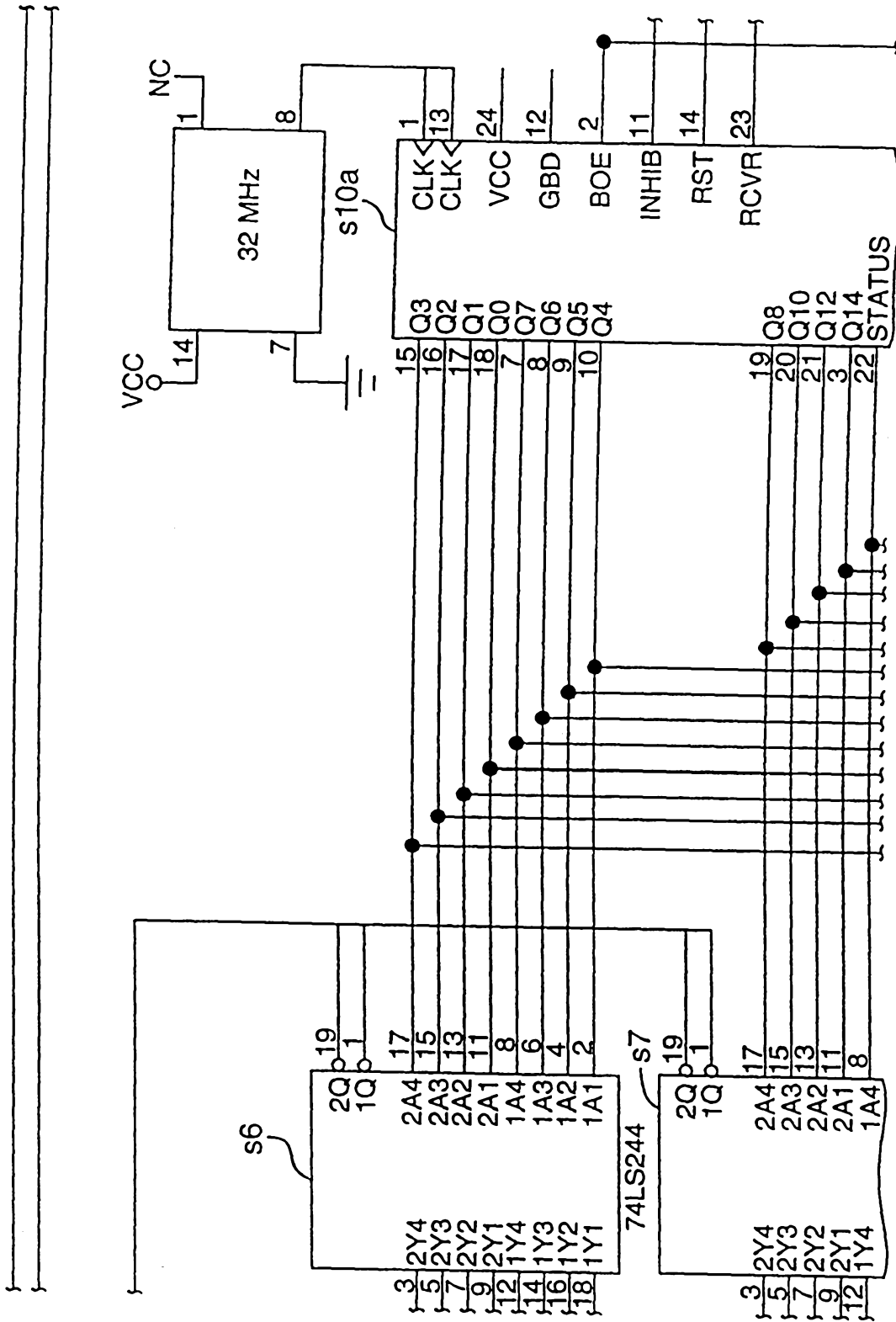
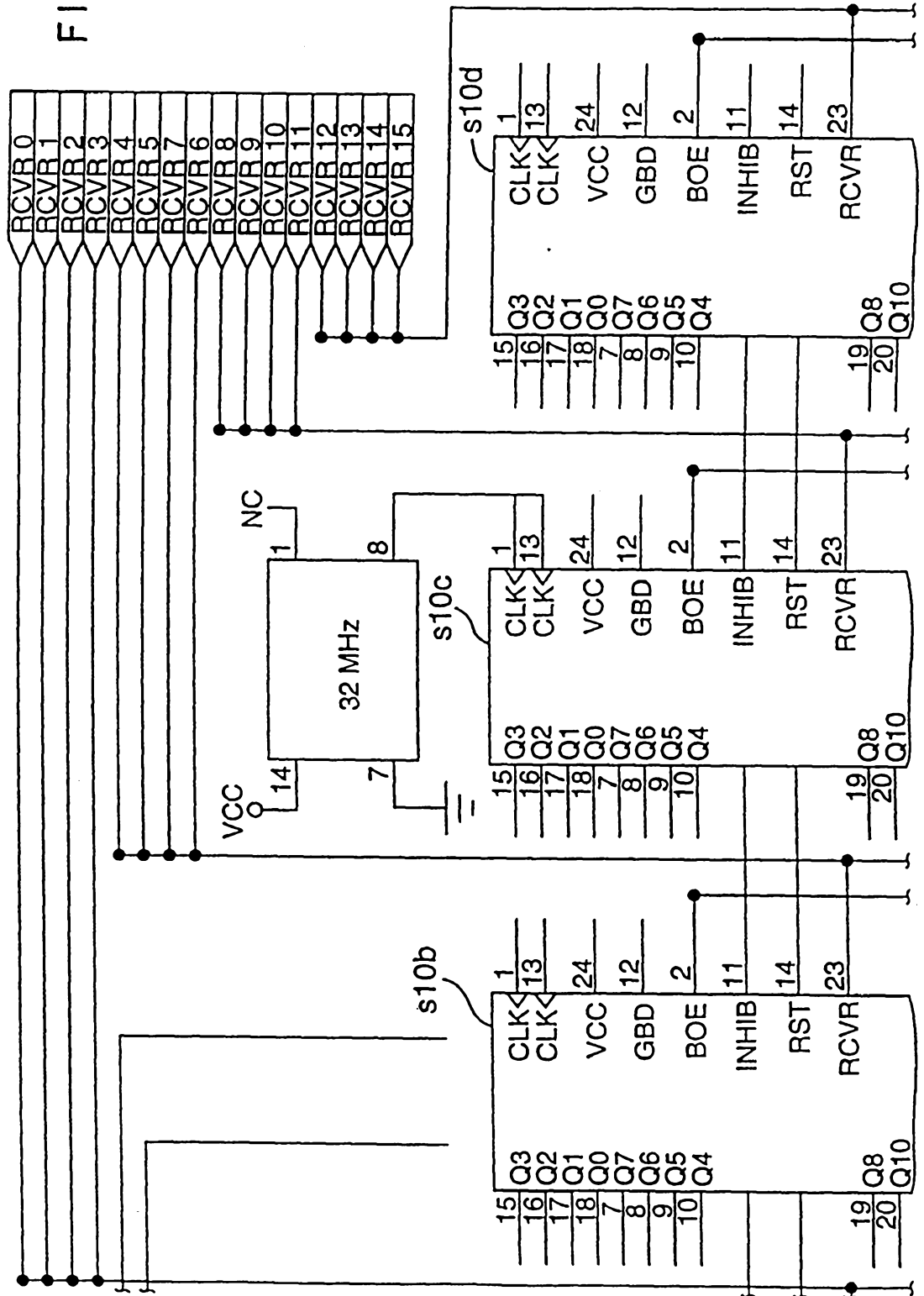

FIG.4C.

FIG. 4D.



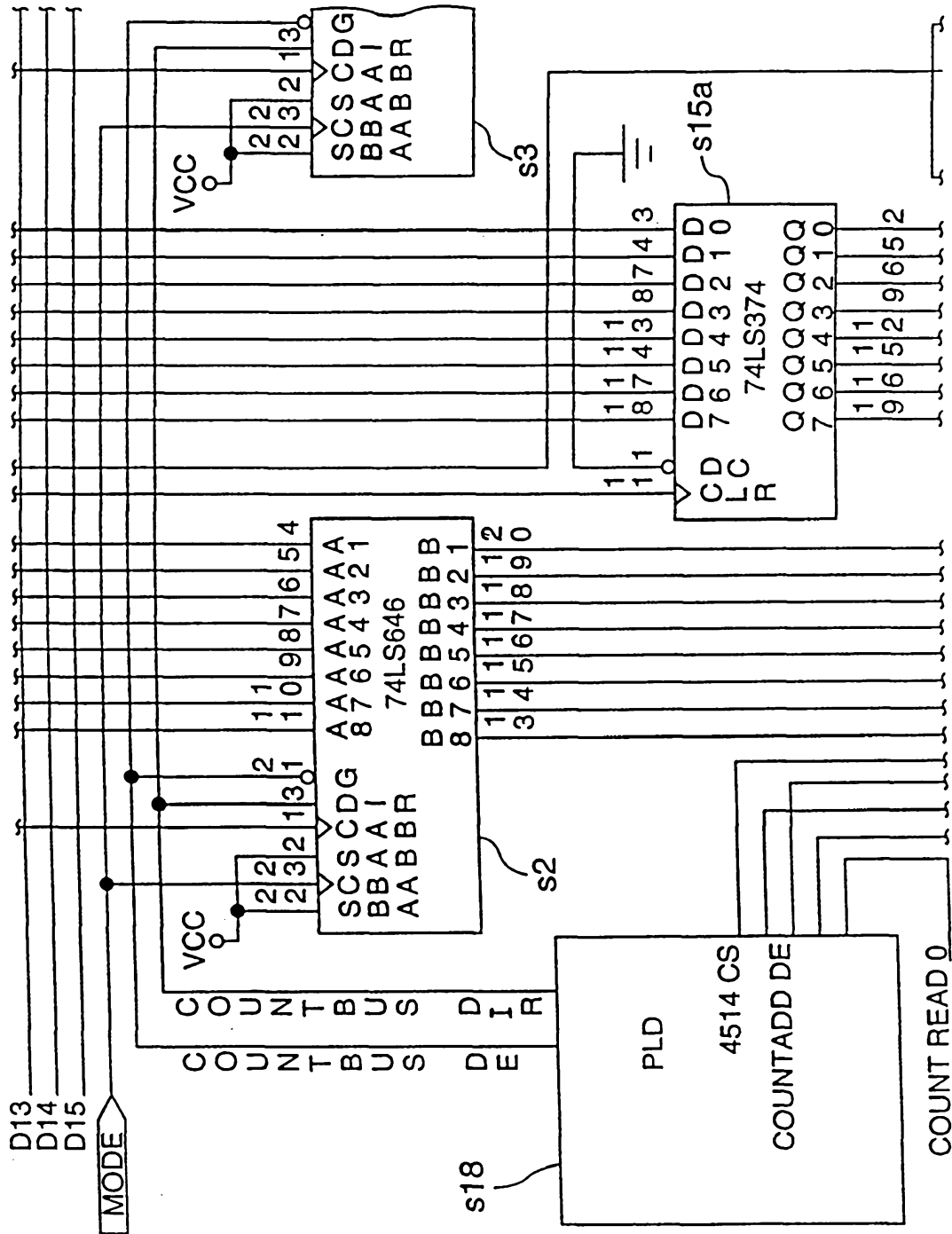

FIG. 4E.

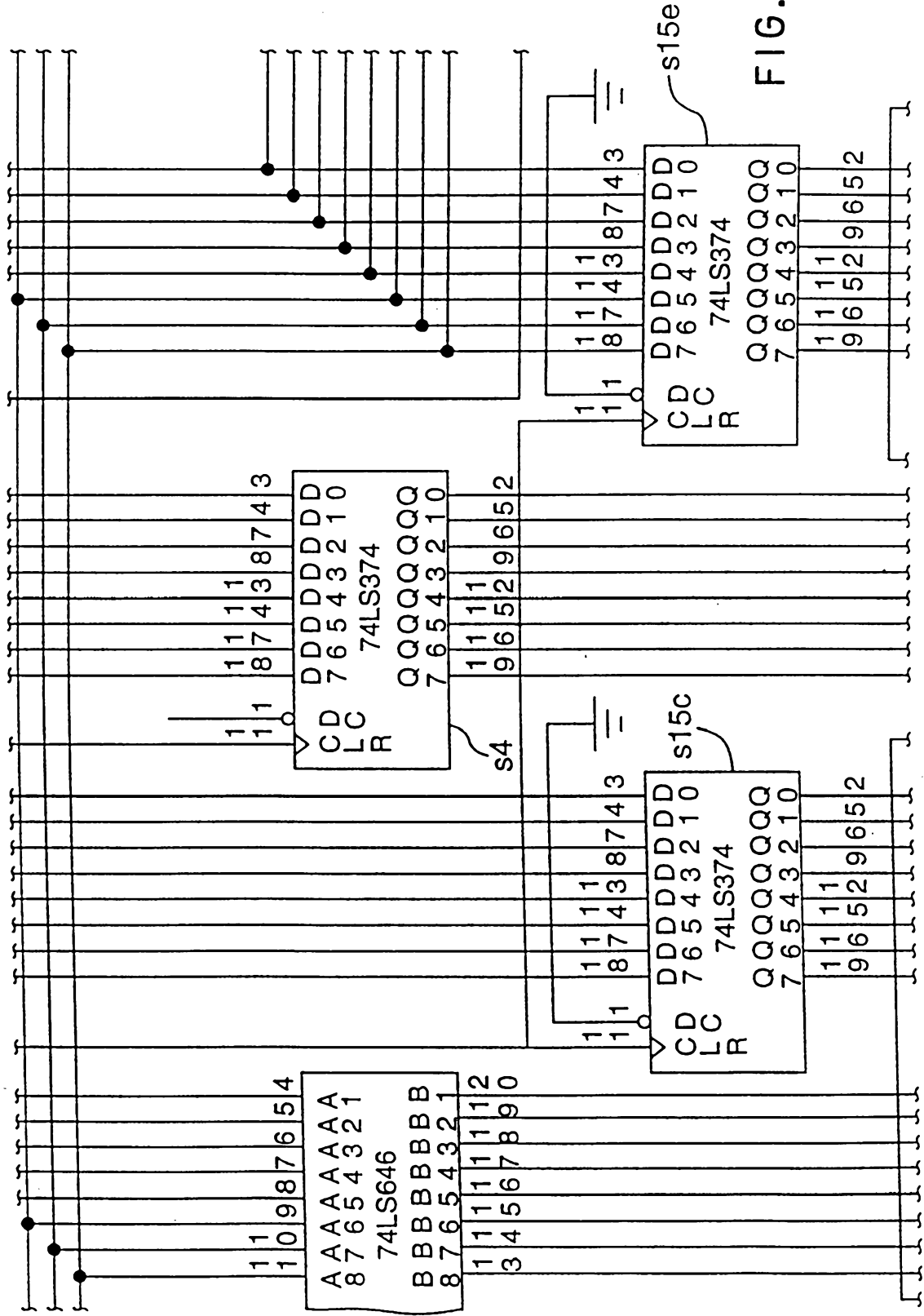

FIG. 4F.

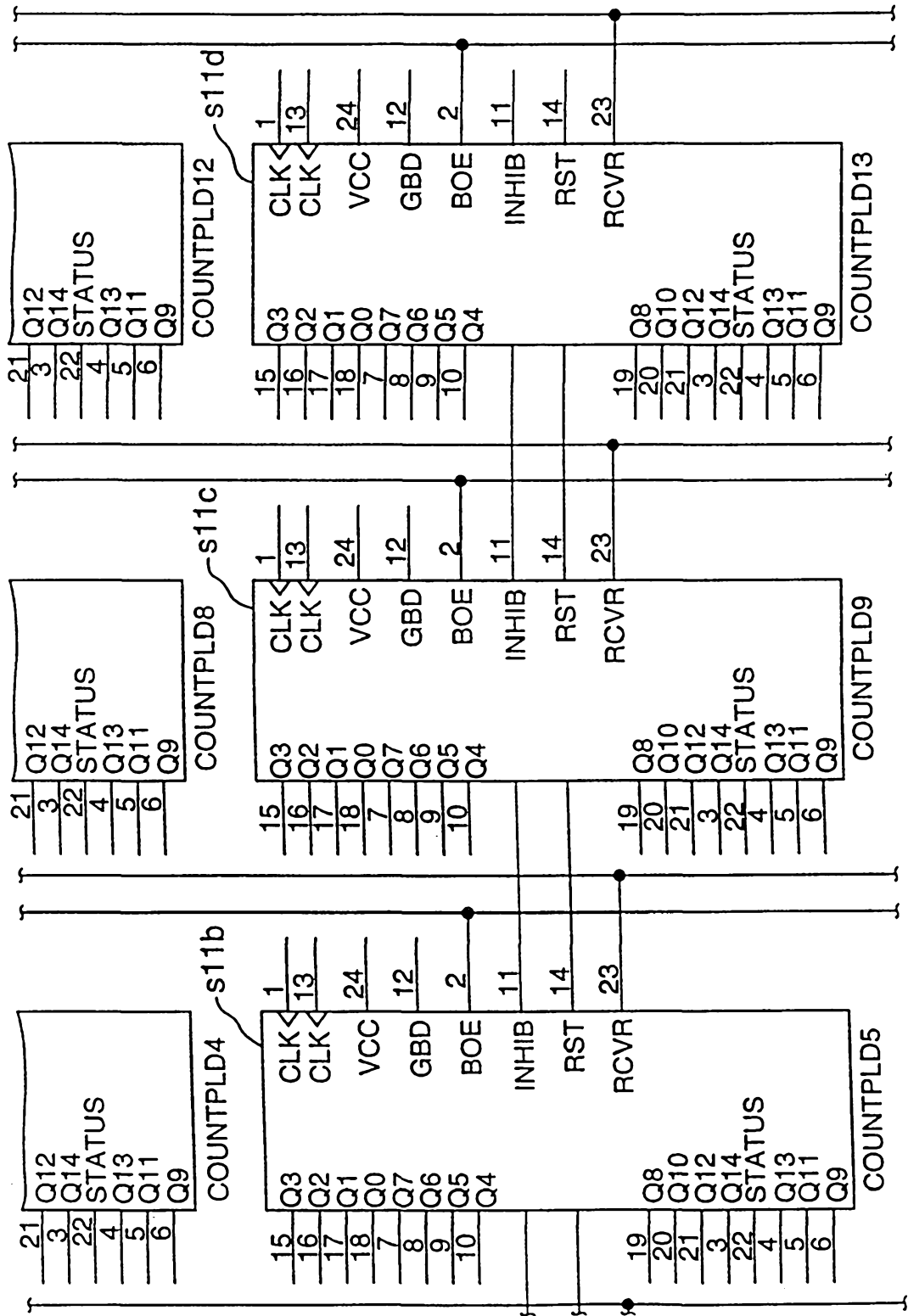
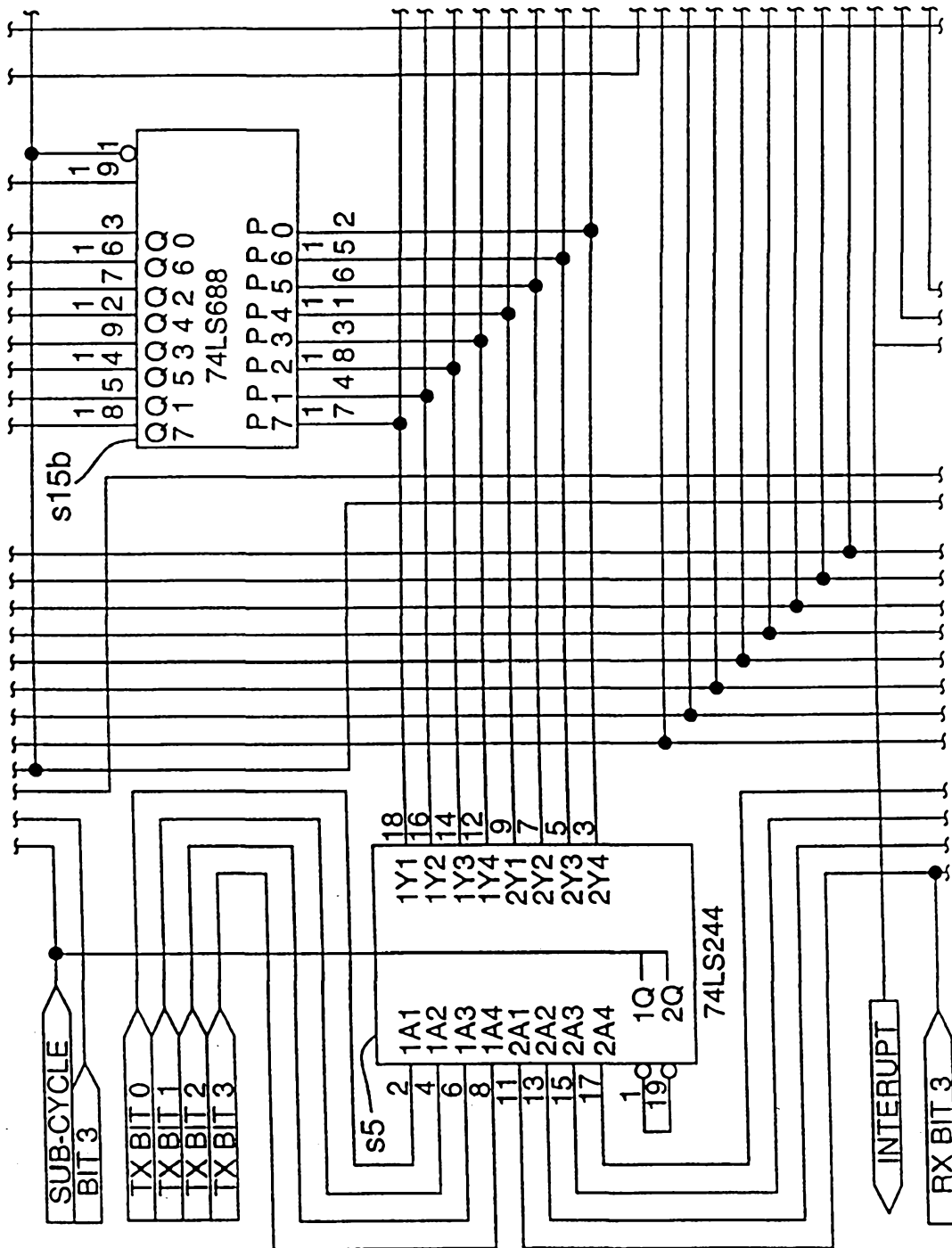

FIG. 4H.

FIG. 4I.



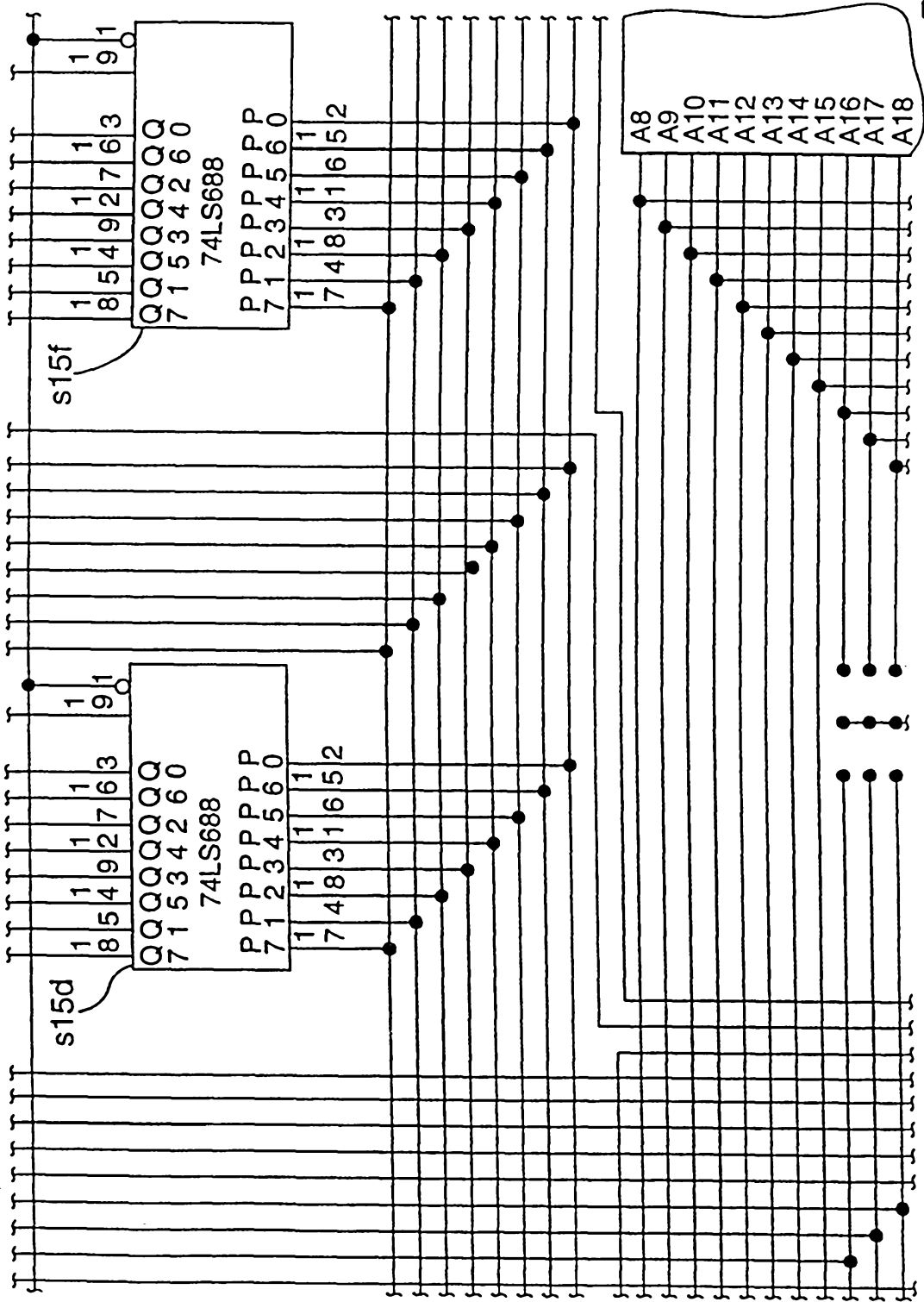

FIG. 4J.

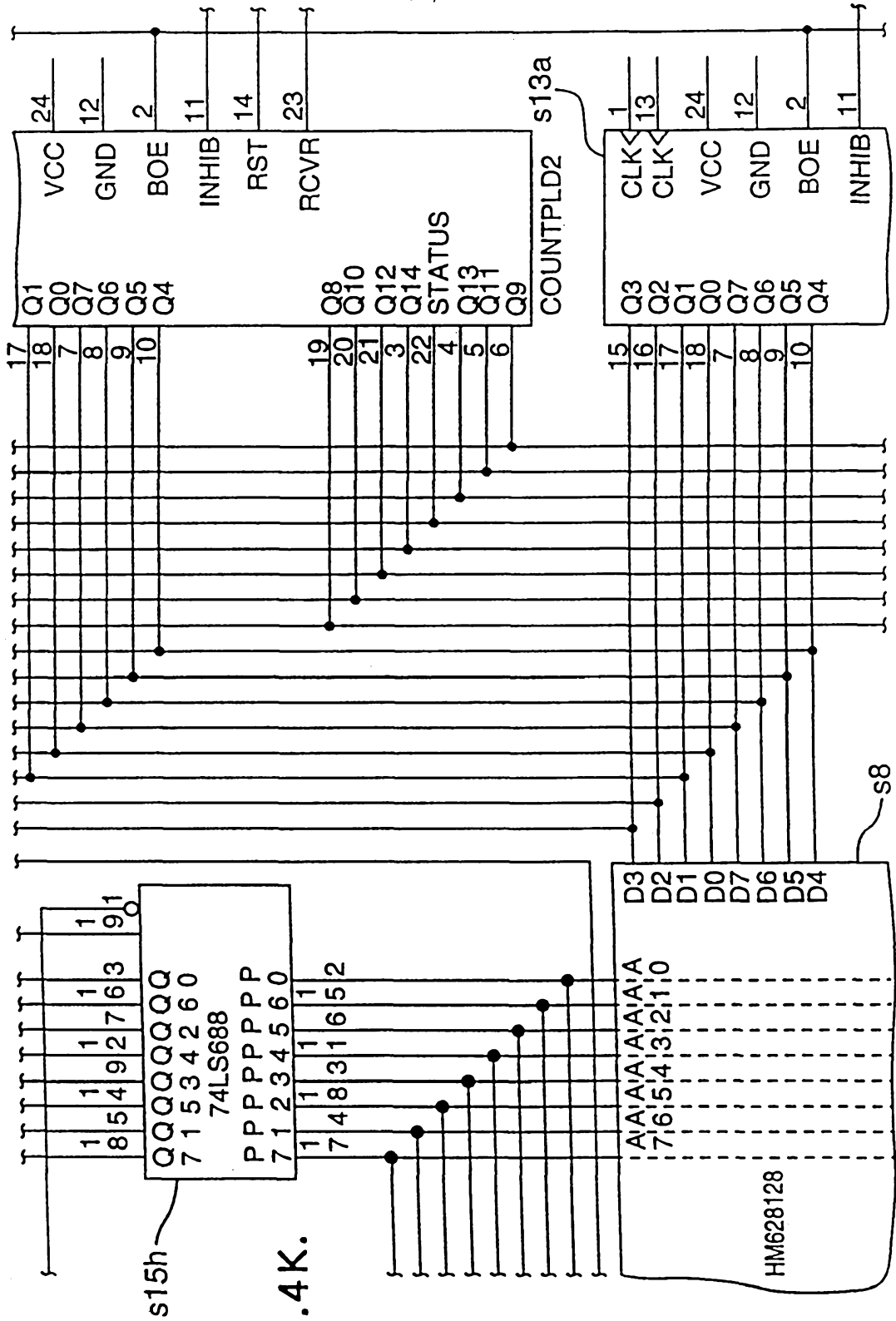
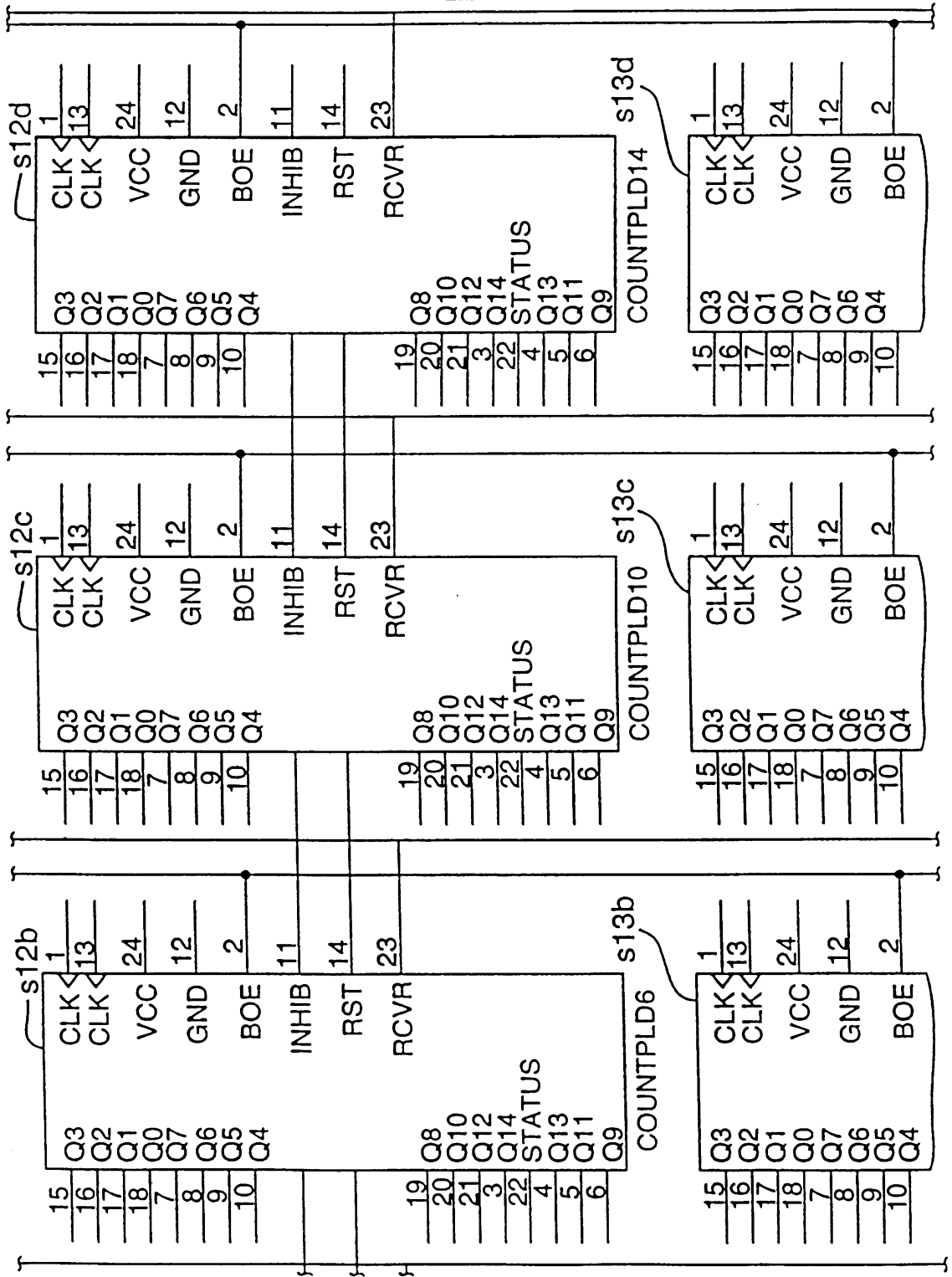

FIG. 4K.

FIG. 4L.



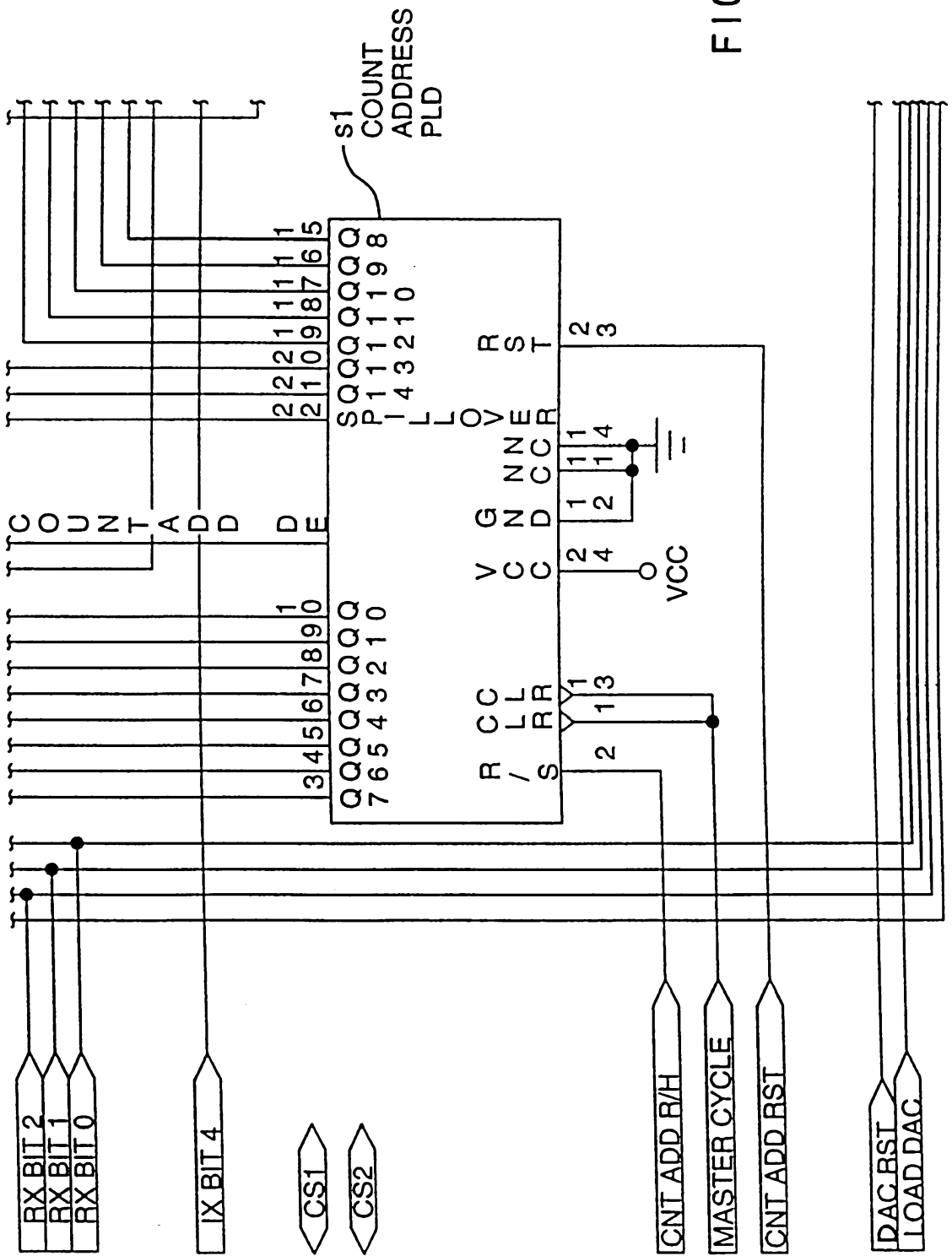

FIG. 4M.

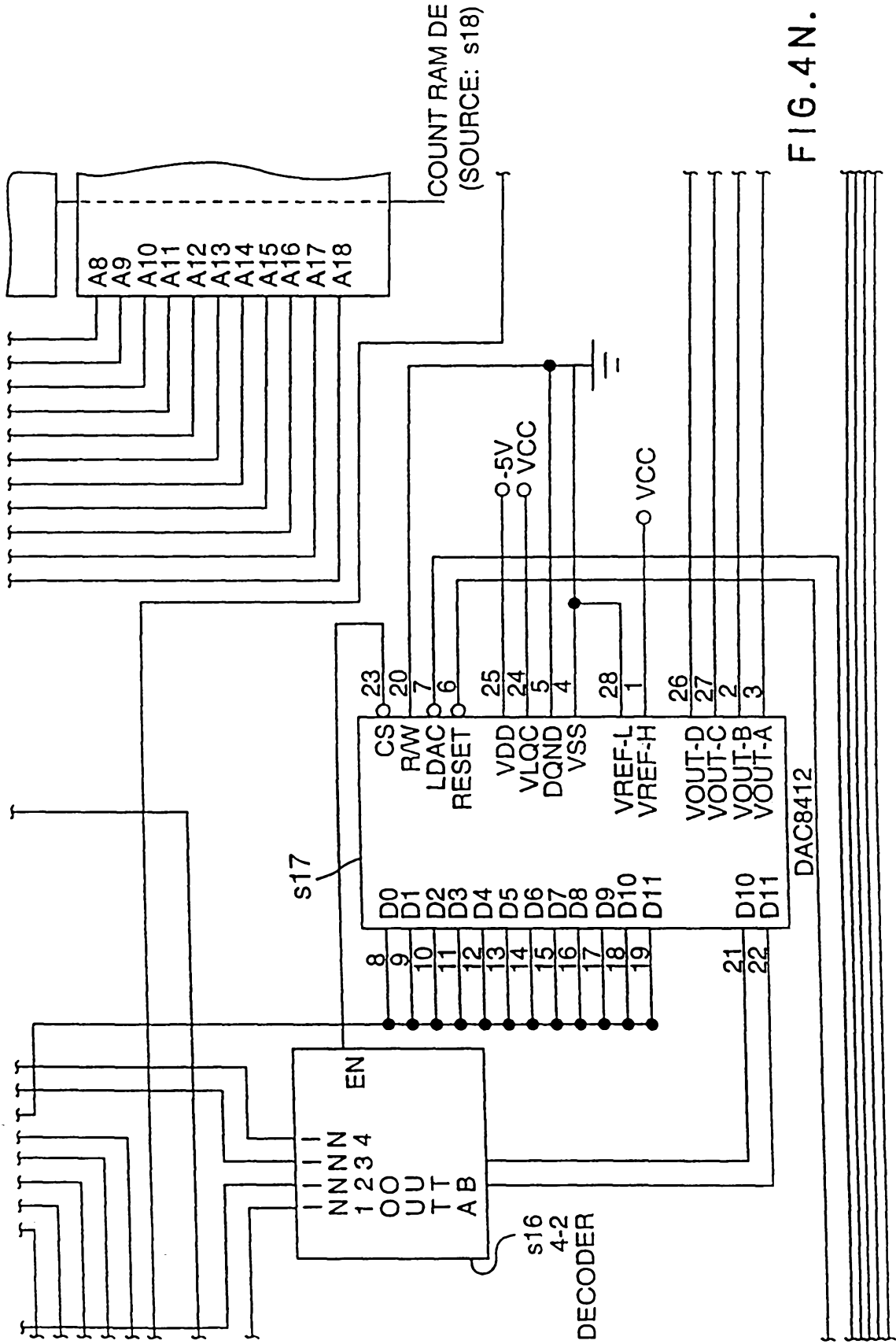

FIG. 4N.

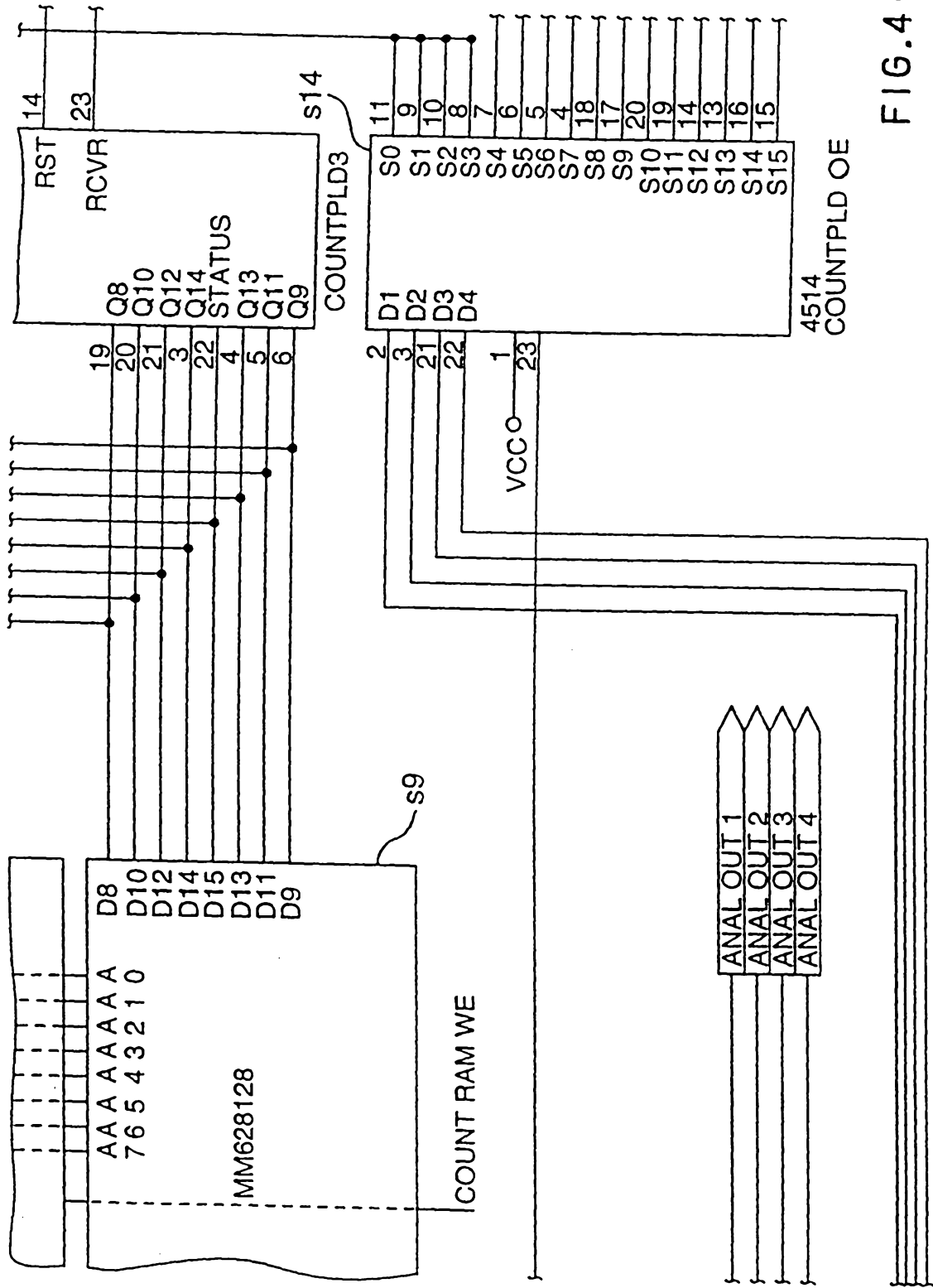

FIG.40.

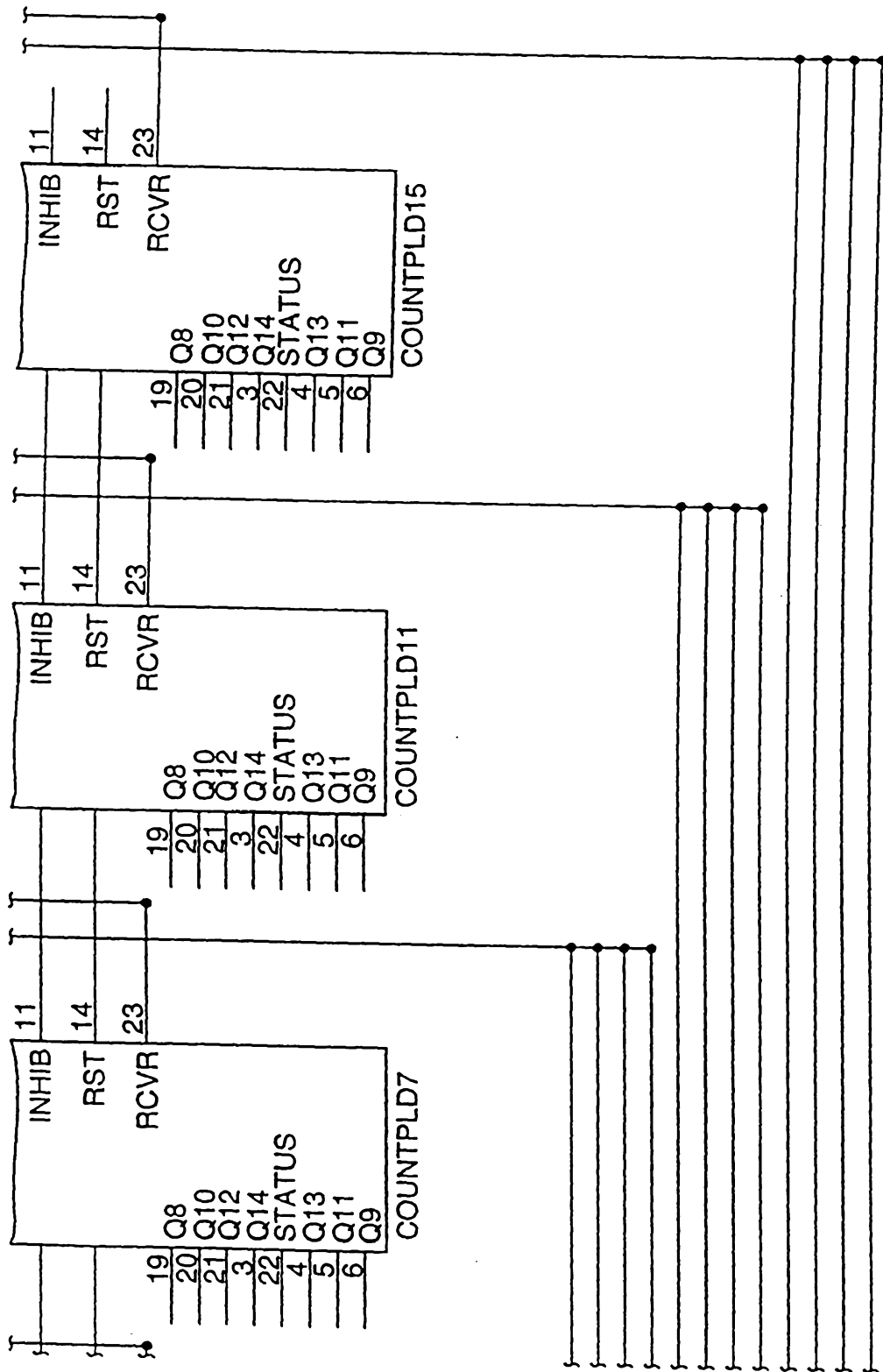

FIG.4P.

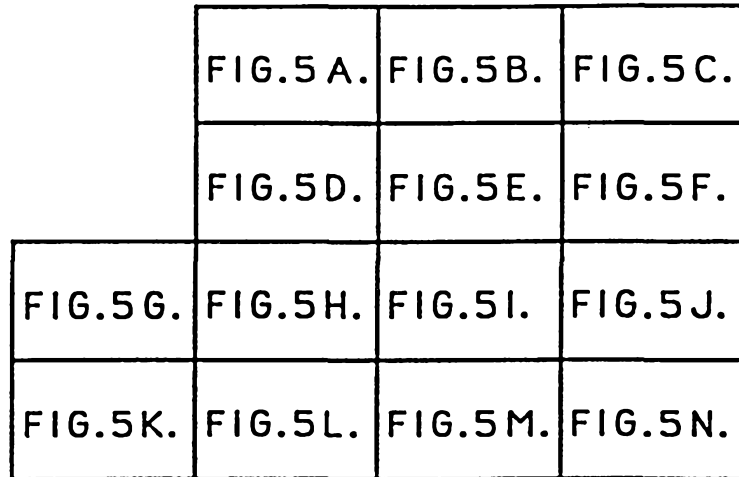

FIG.5.

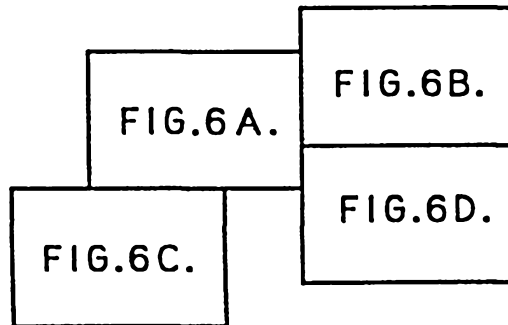

FIG.6.

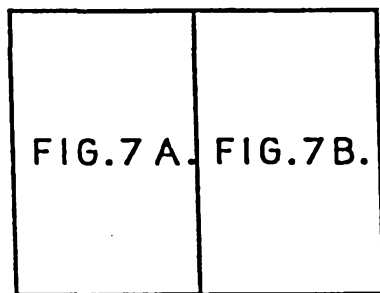

FIG.7.

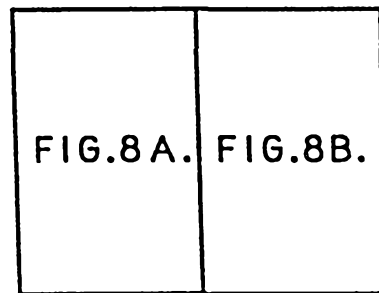

FIG.8.

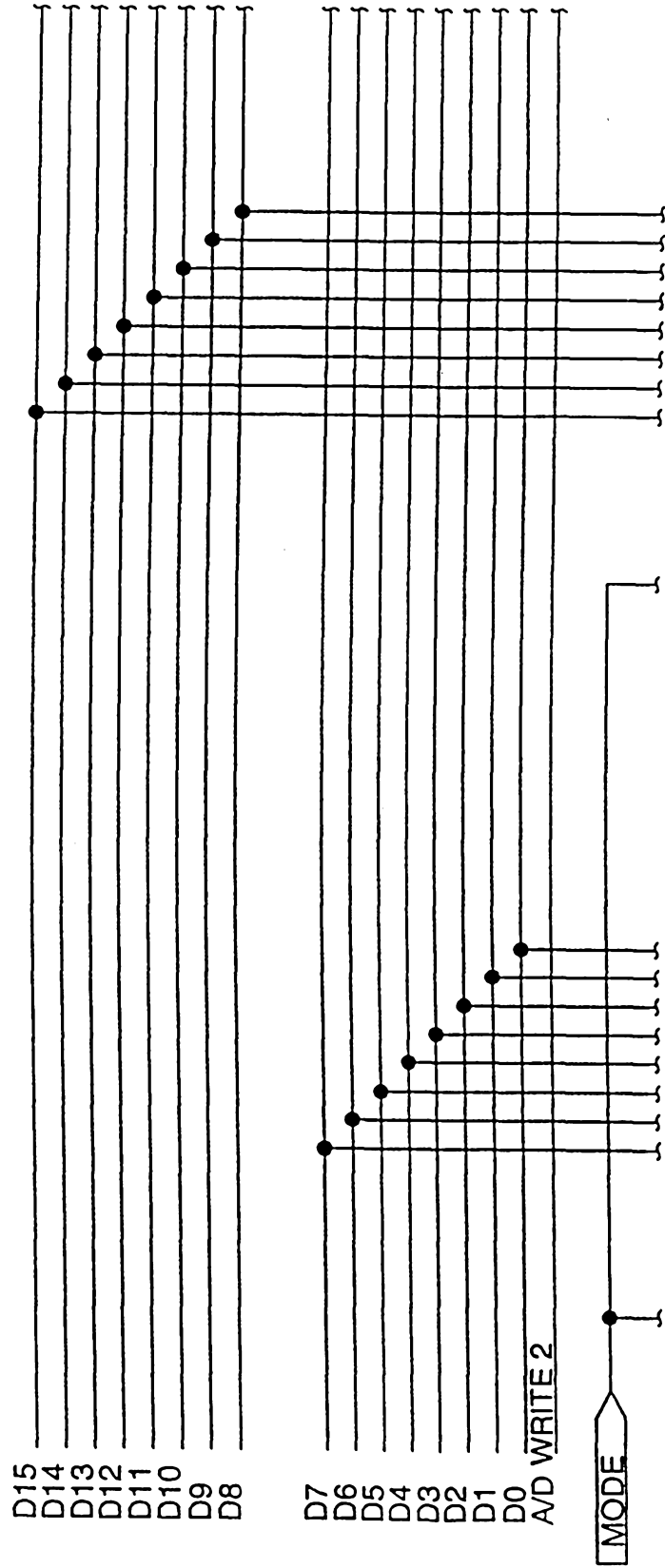

FIG. 5 A.

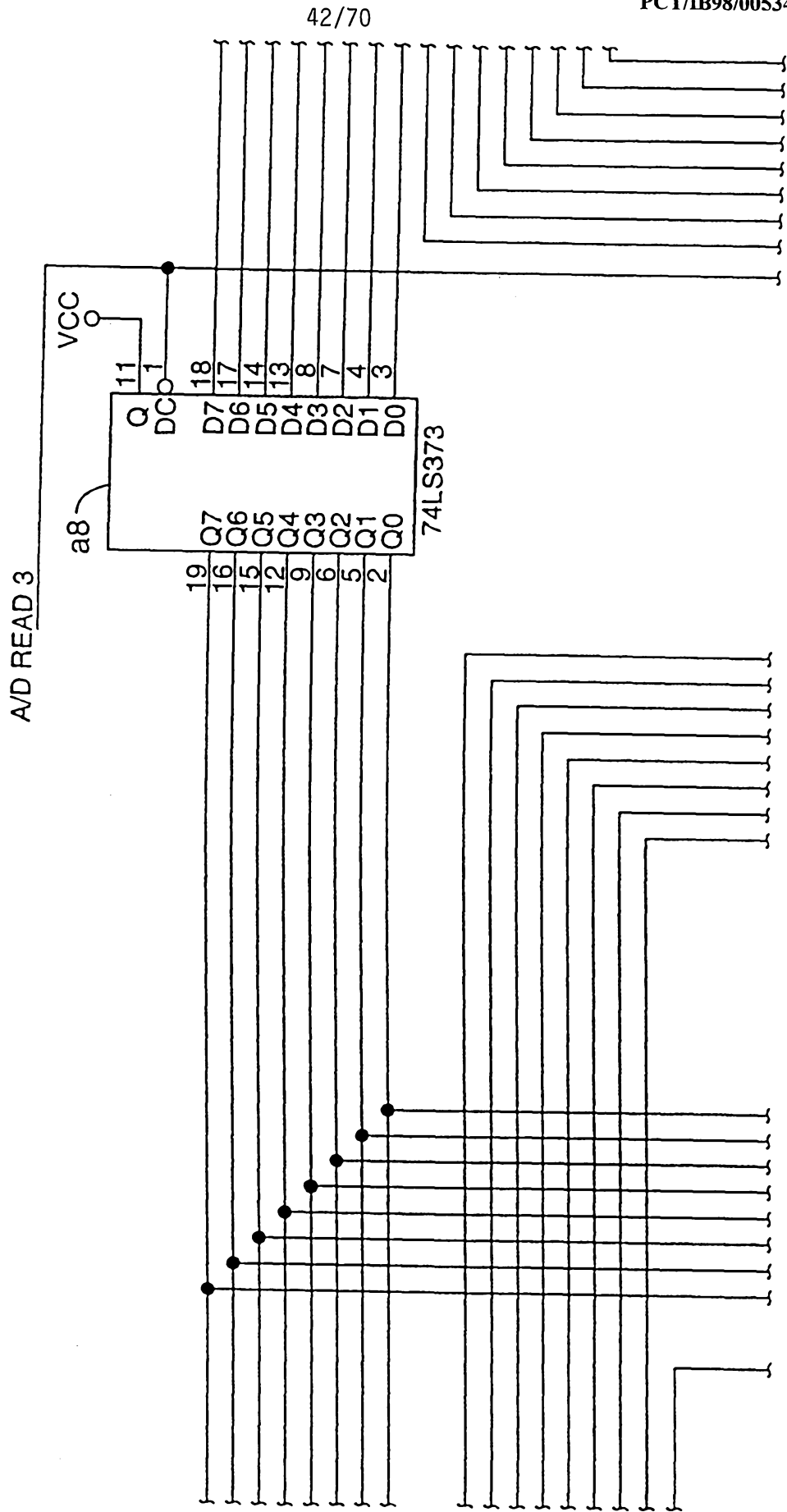

FIG. 5B.

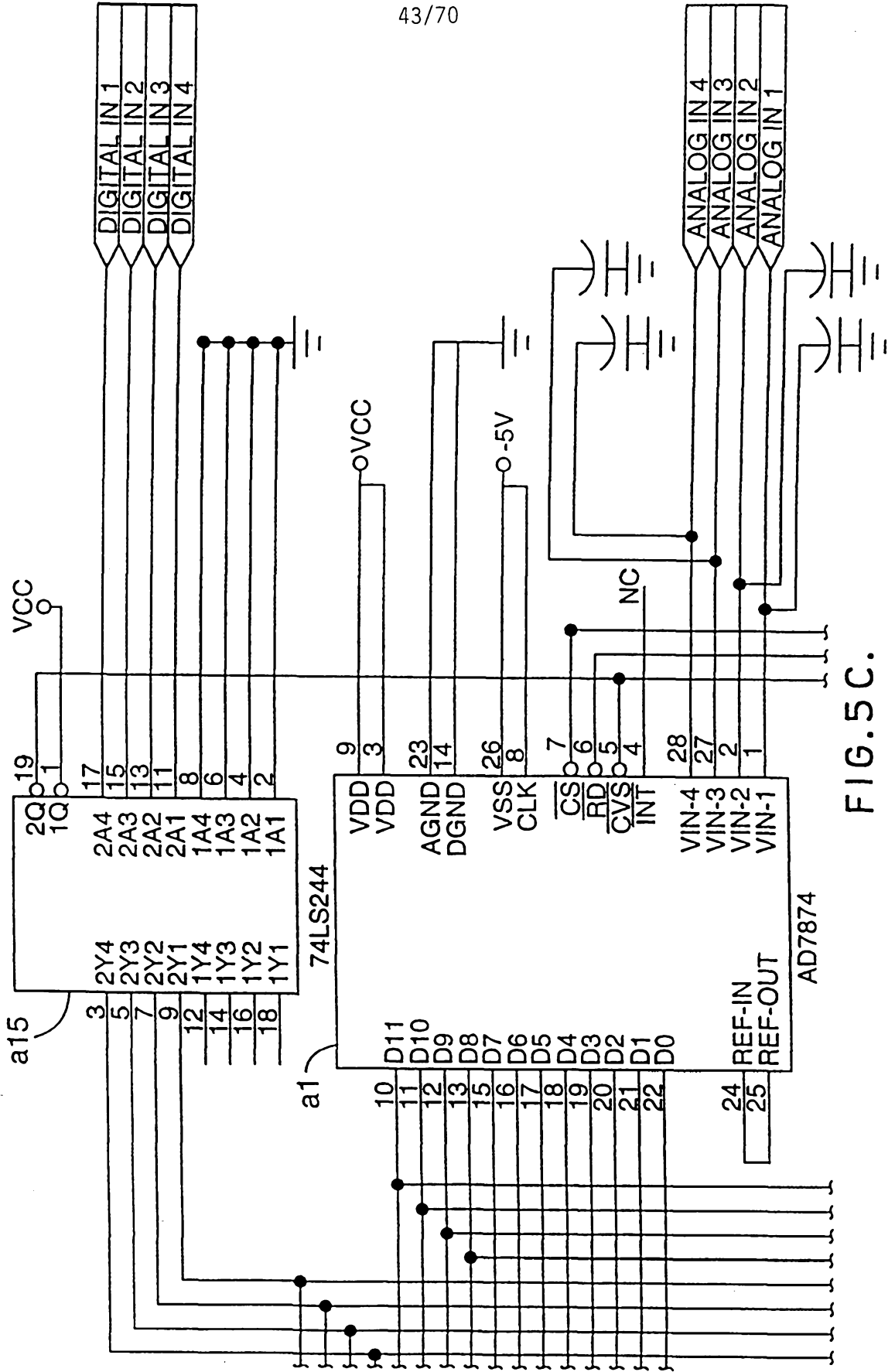

FIG. 5C.

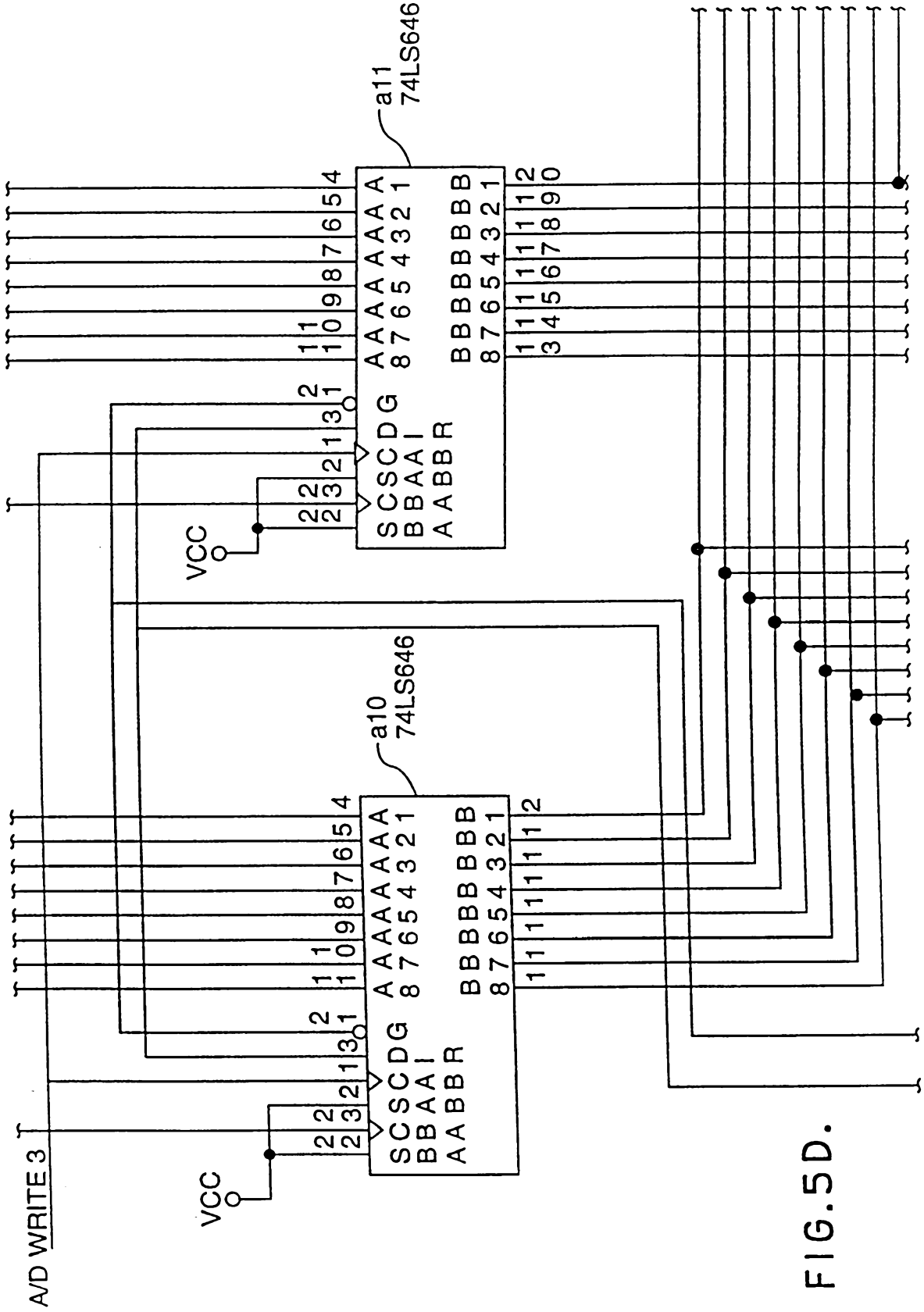

FIG.5D.

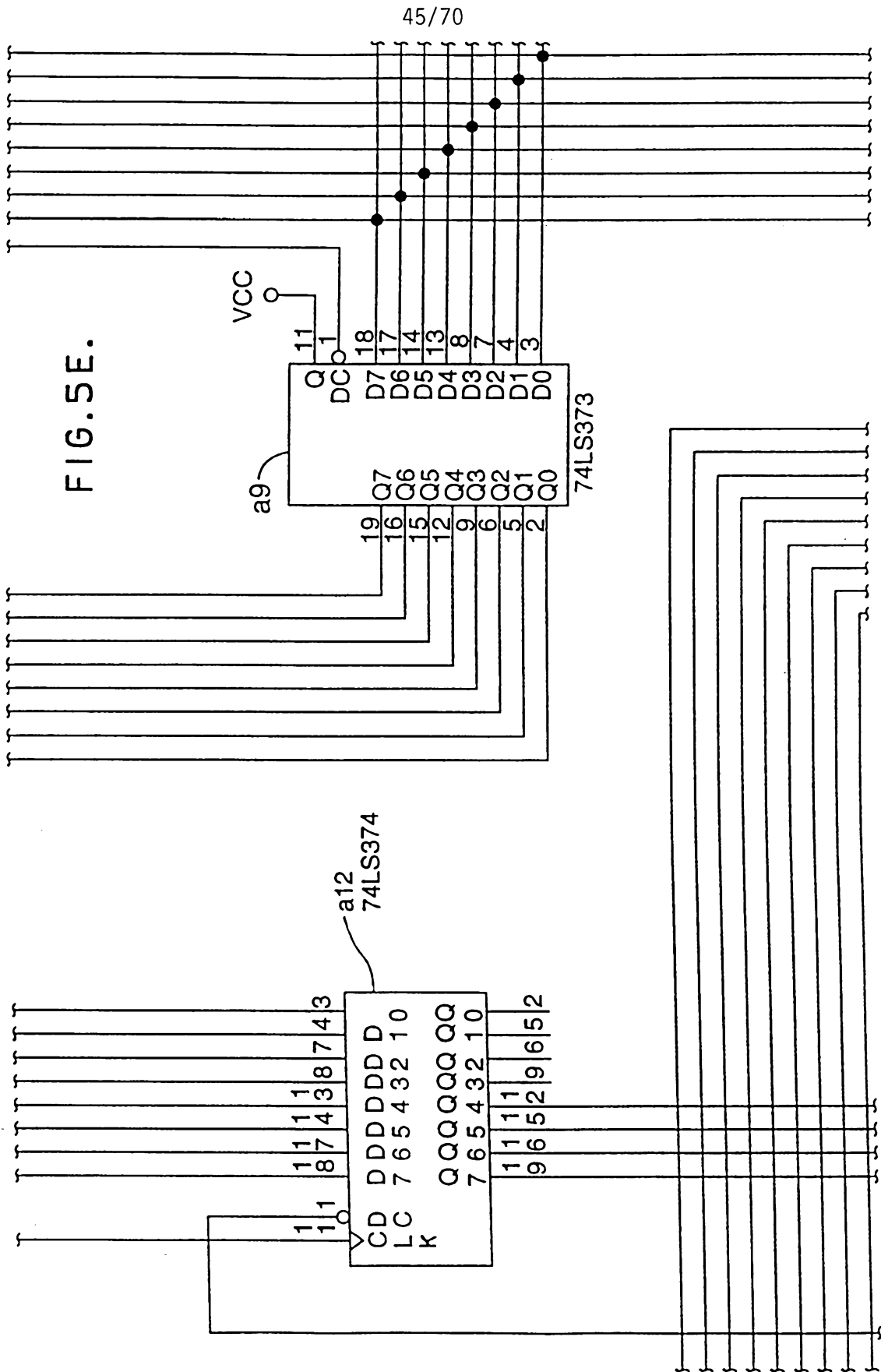
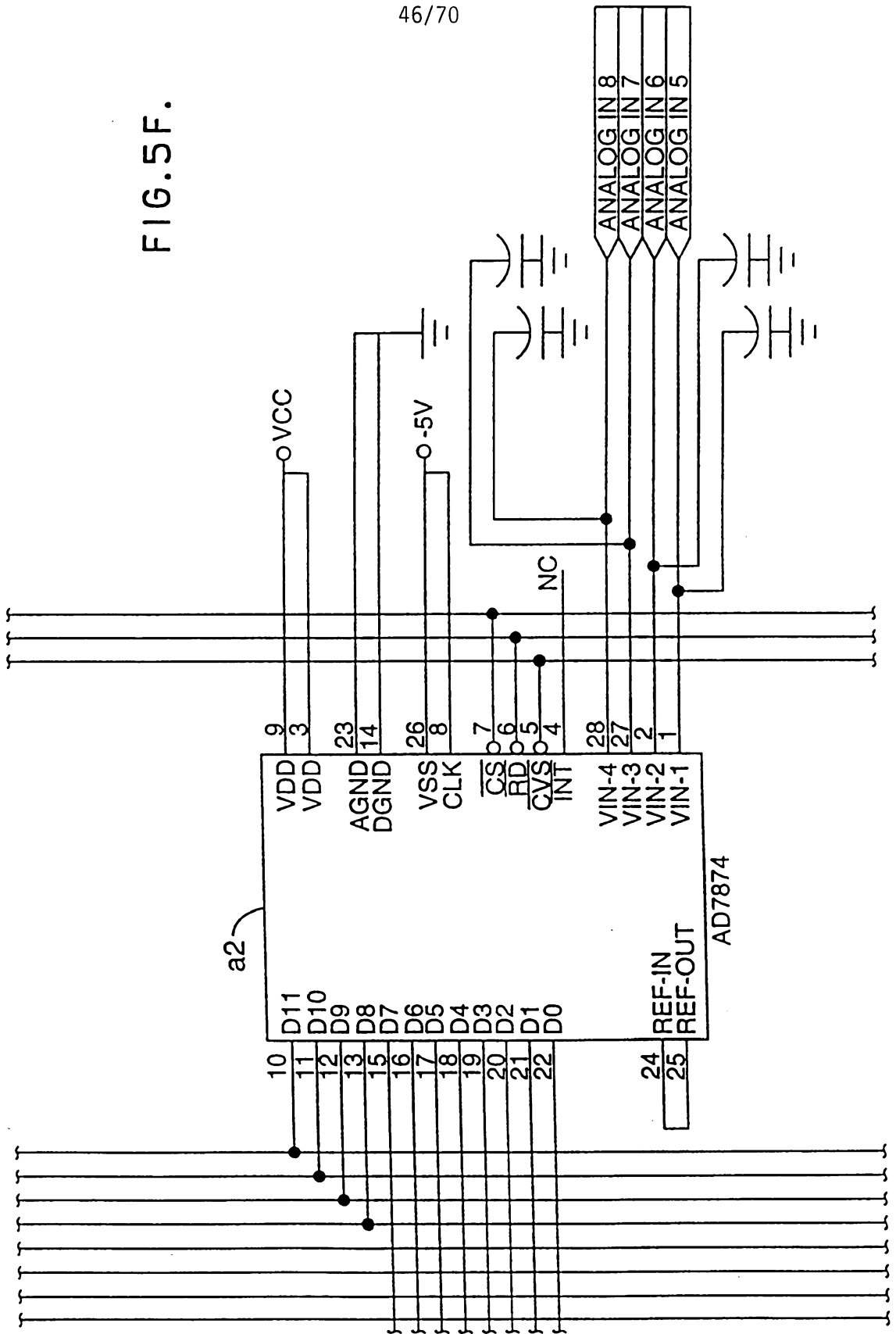

FIG. 5F.



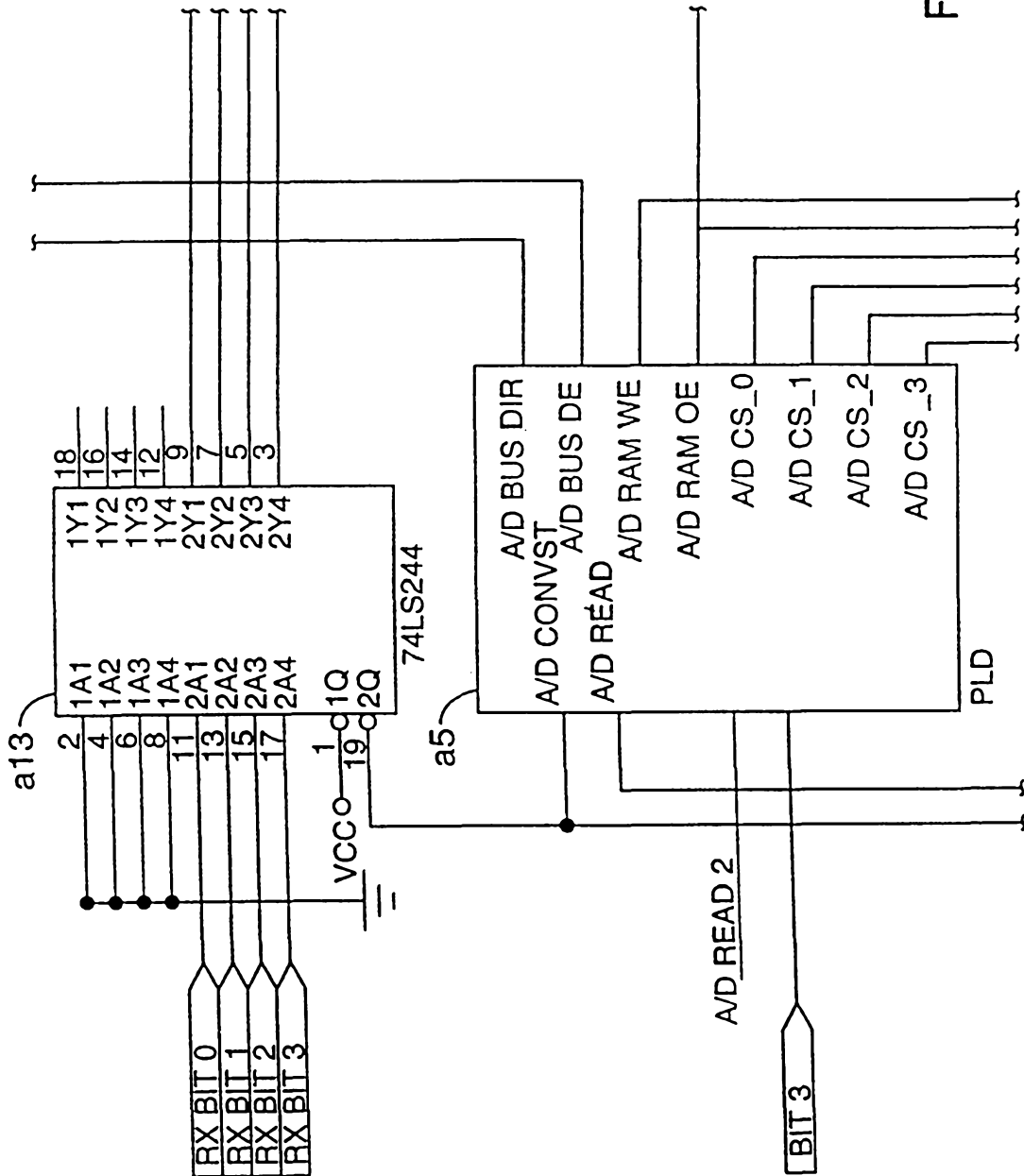

FIG. 56.

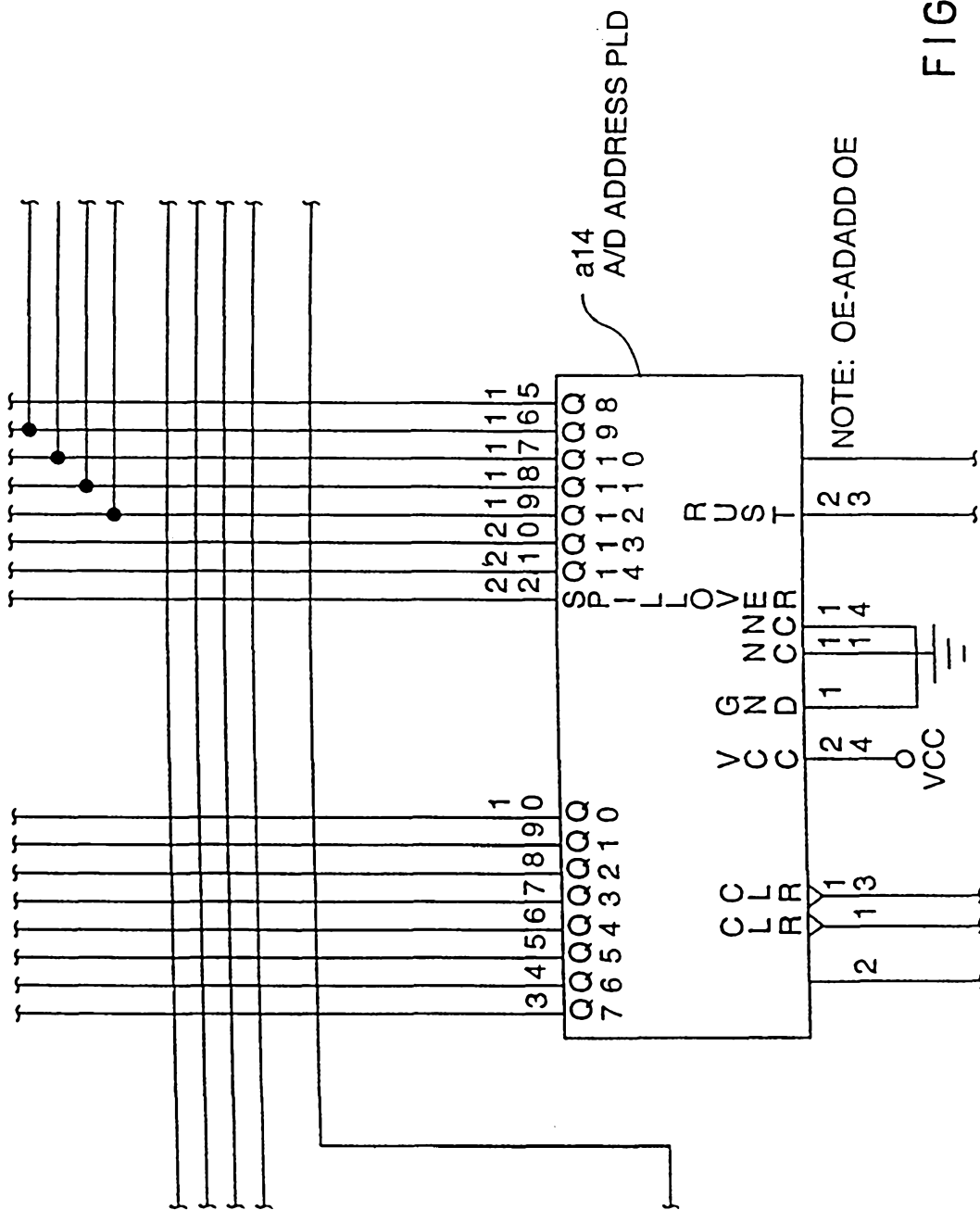

FIG. 5H.

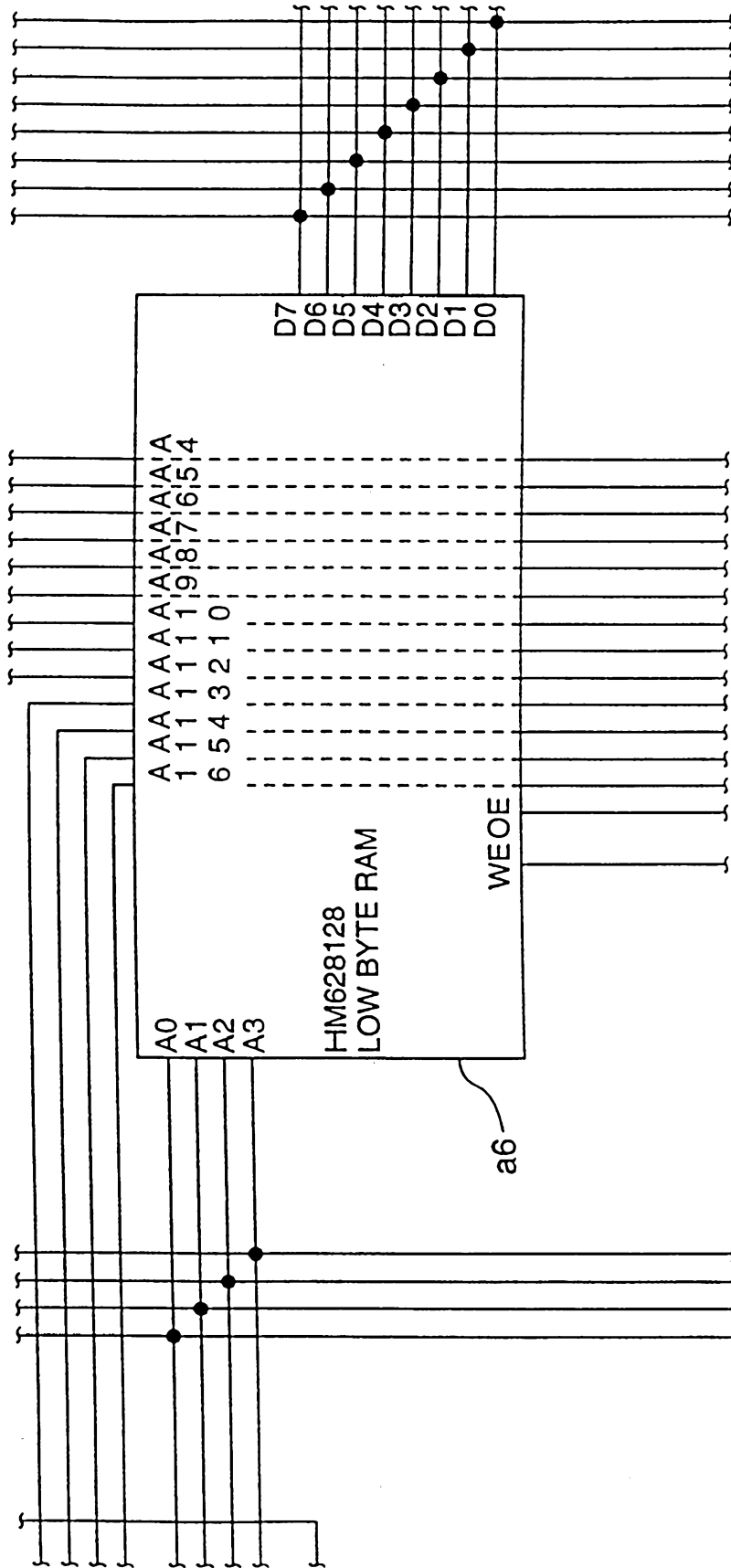

FIG. 5I.

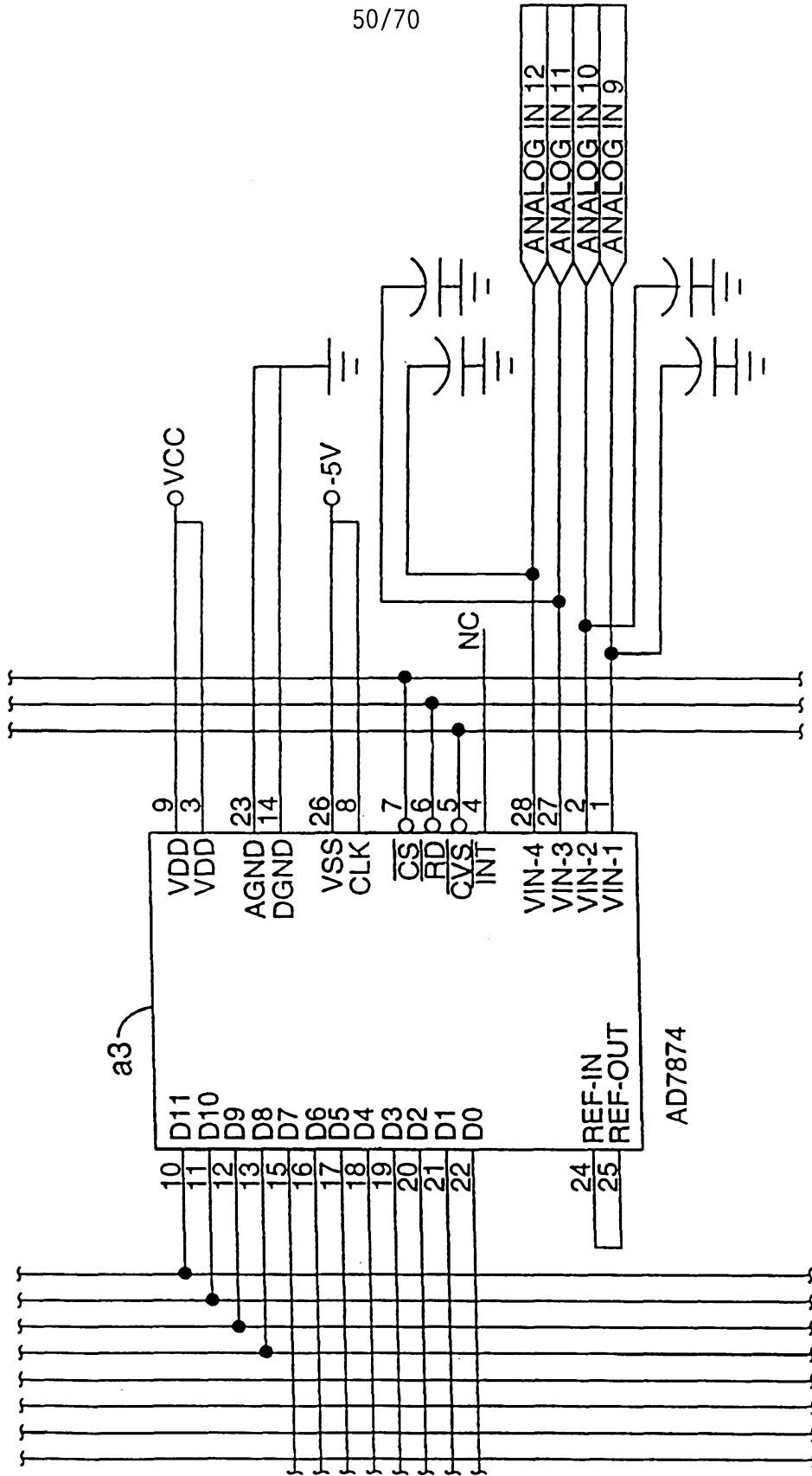

FIG. 5J.

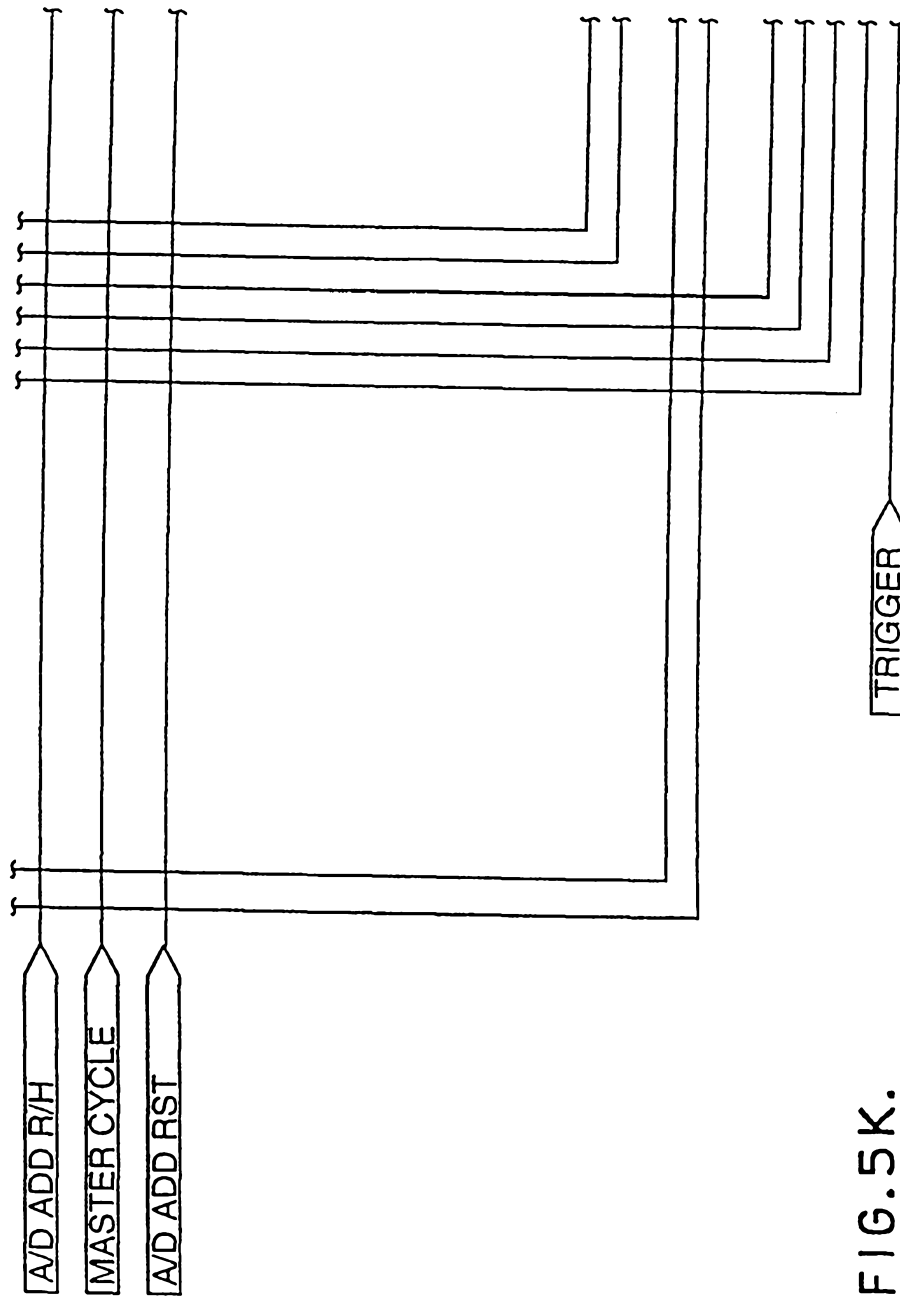

FIG. 5K.

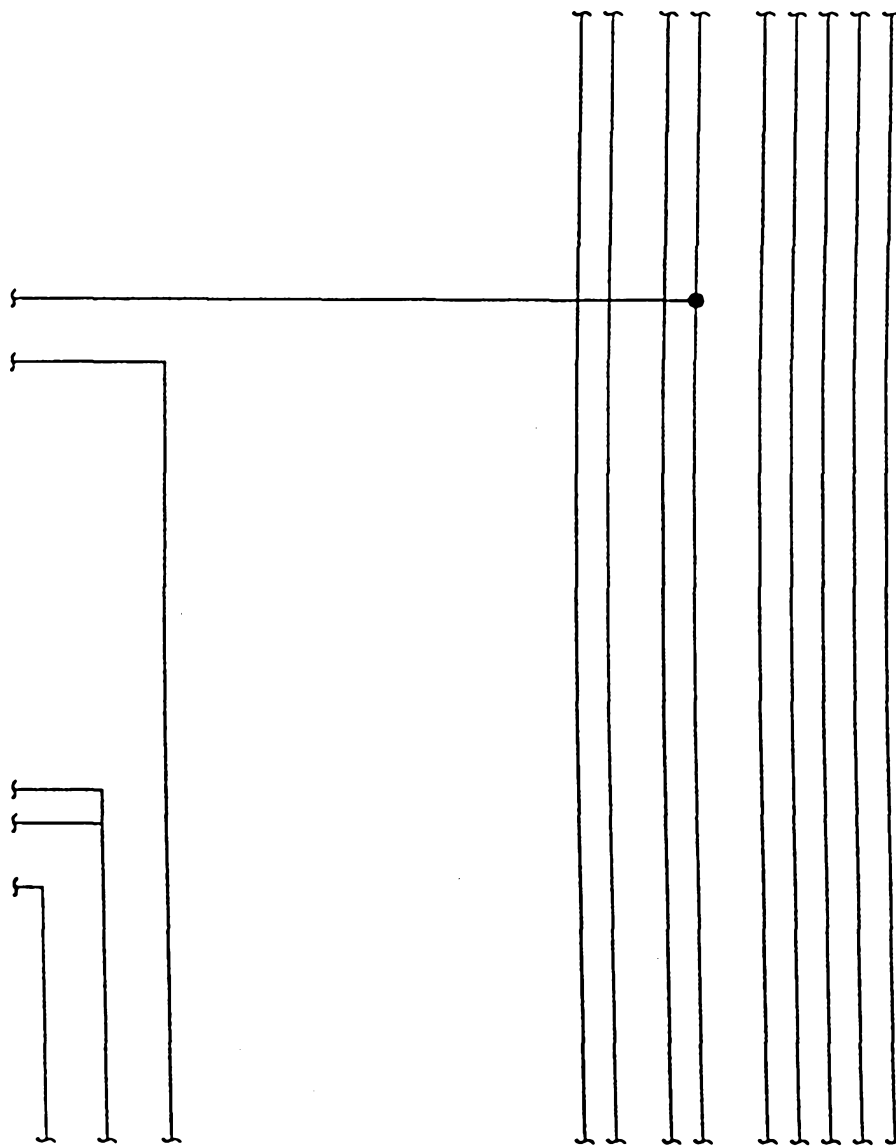

FIG. 5L.

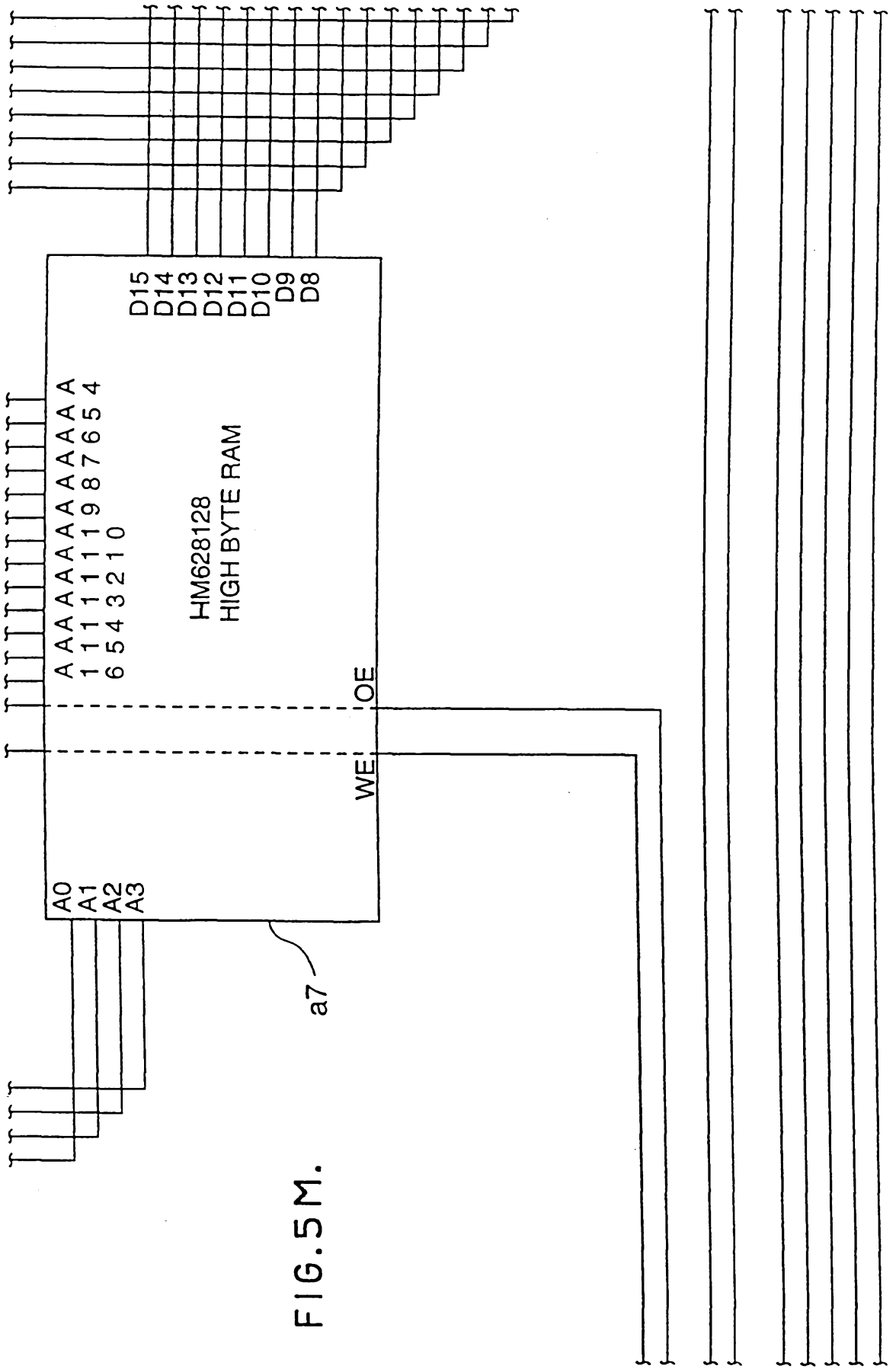
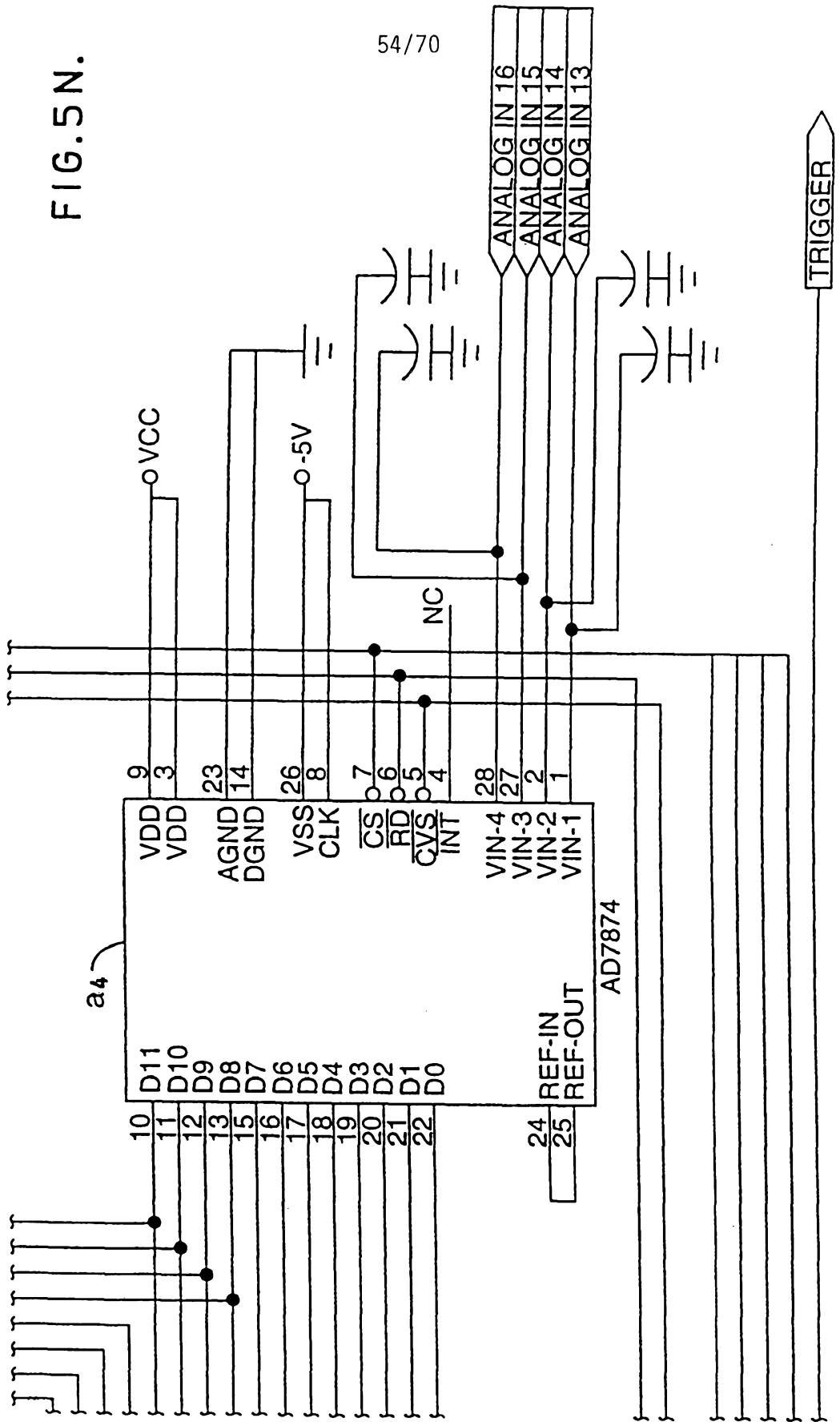

FIG. 5M.

FIG. 5N.



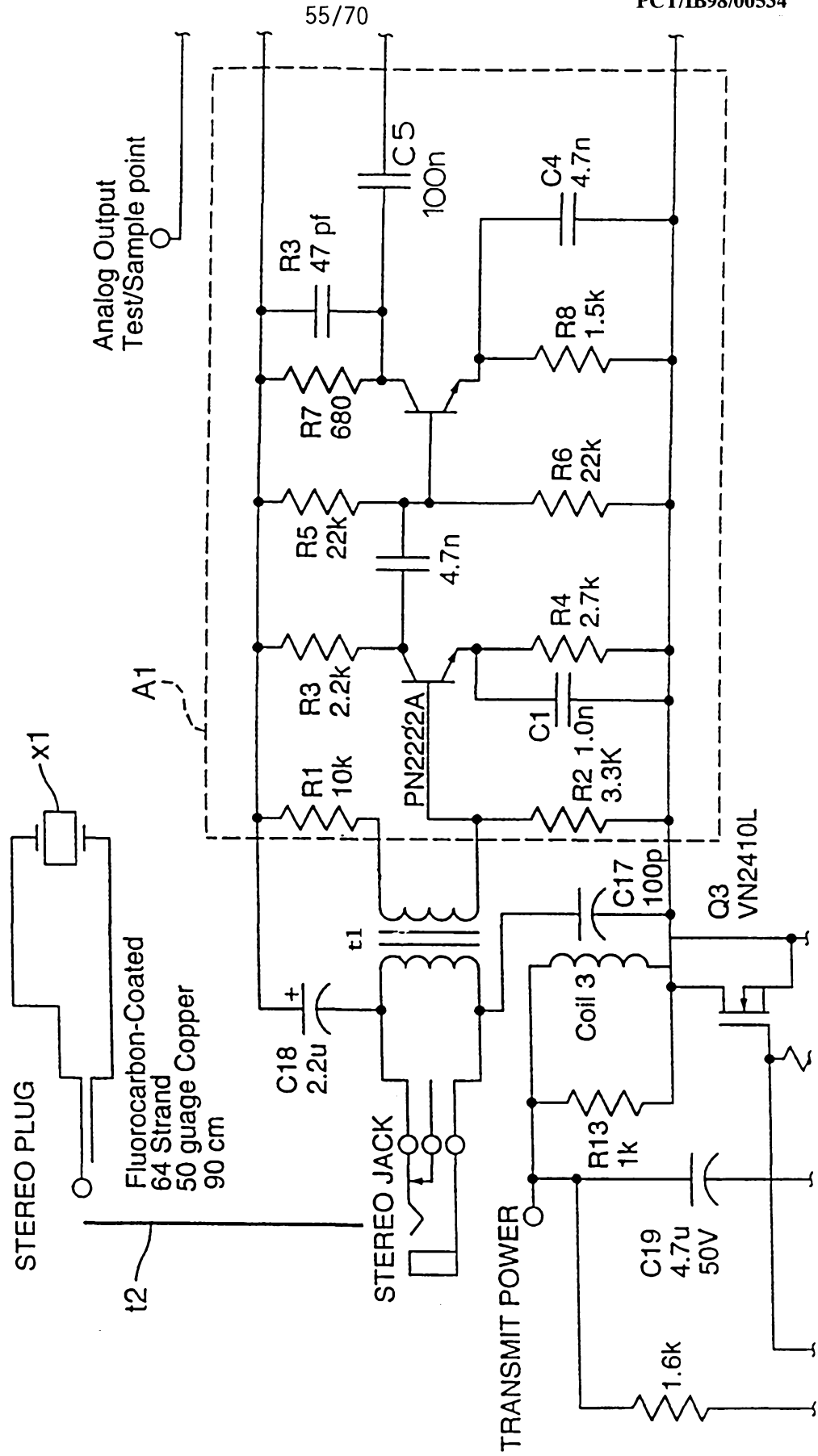

FIG. 6 A.

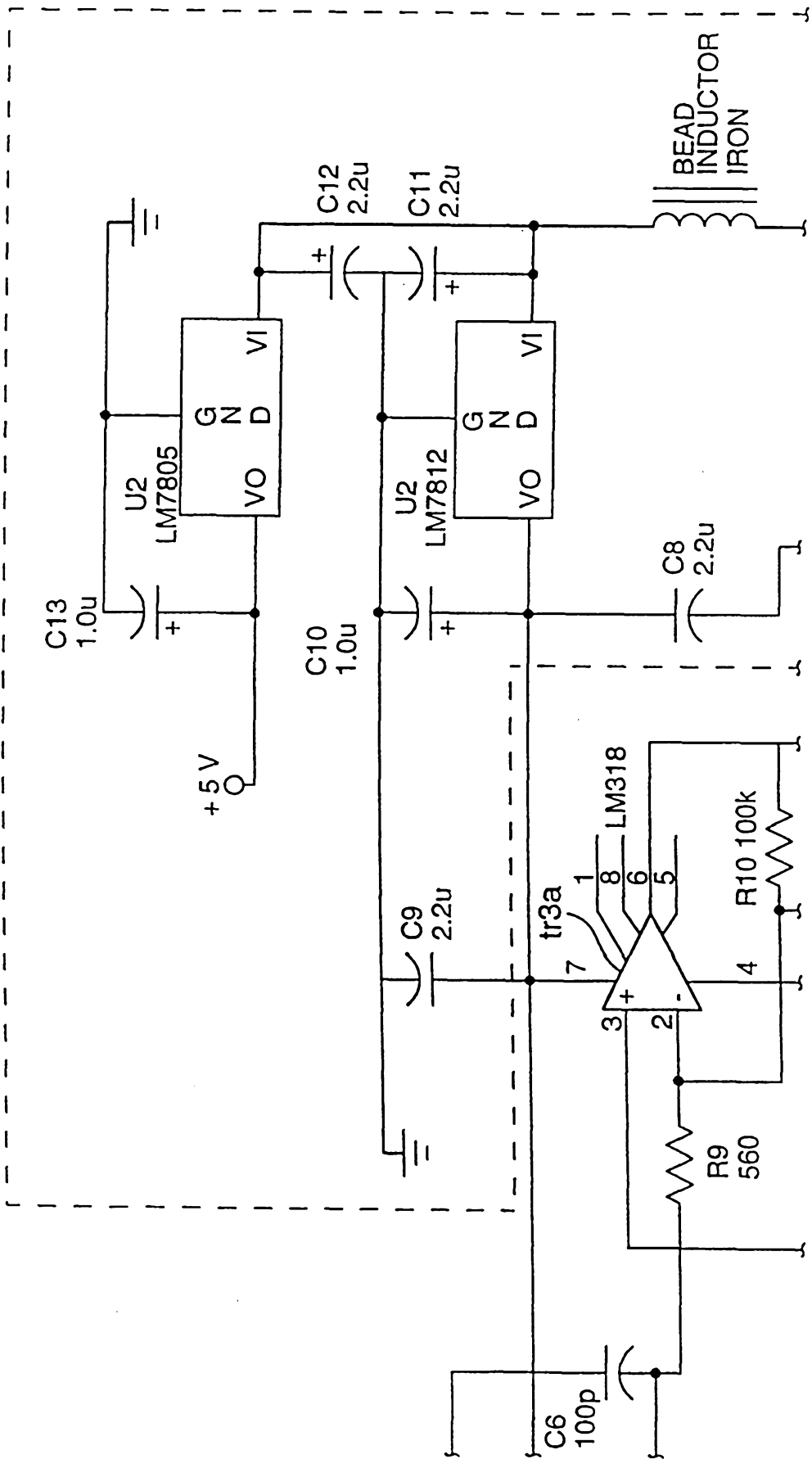

FIG.6B.

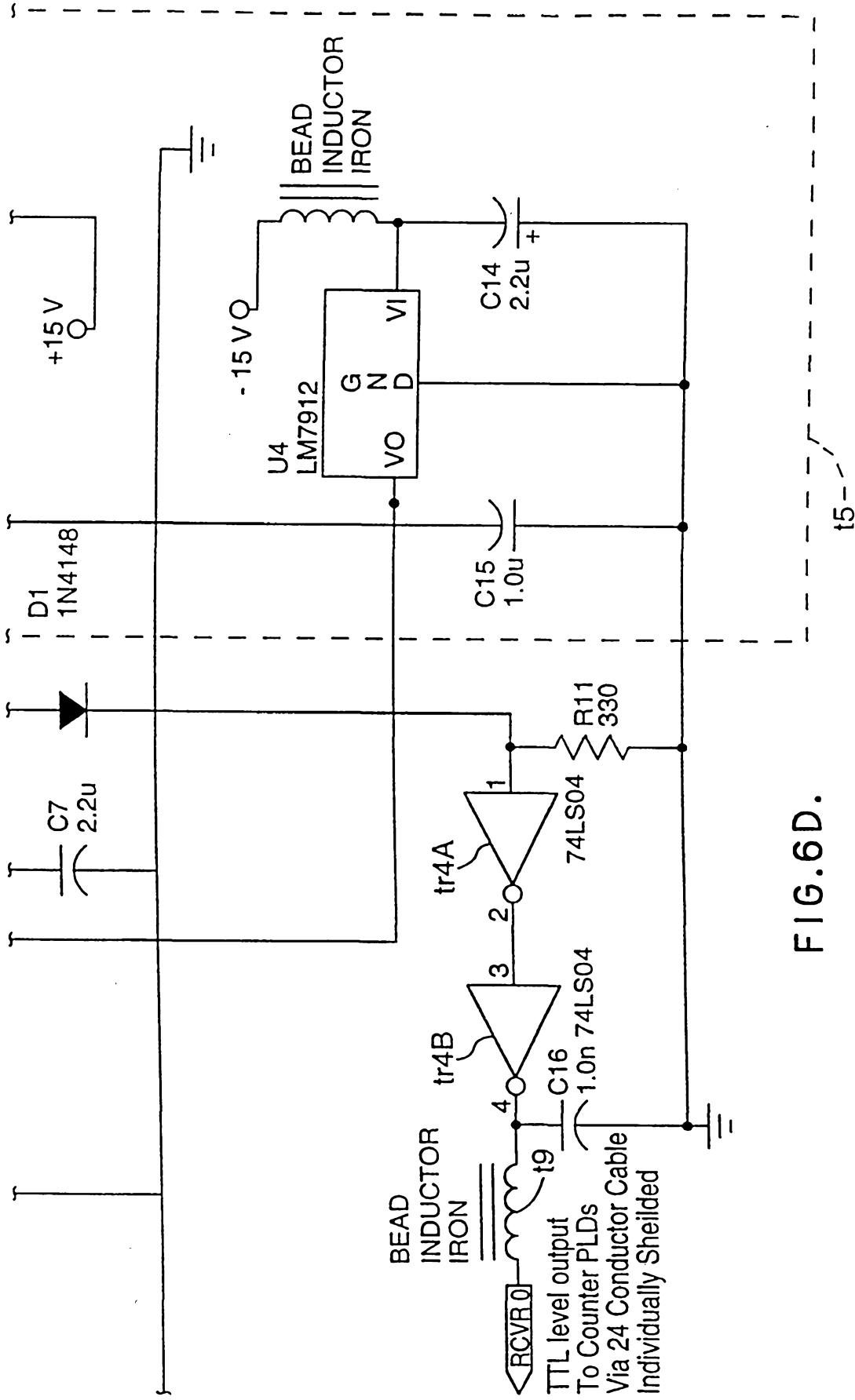

FIG. 6D.

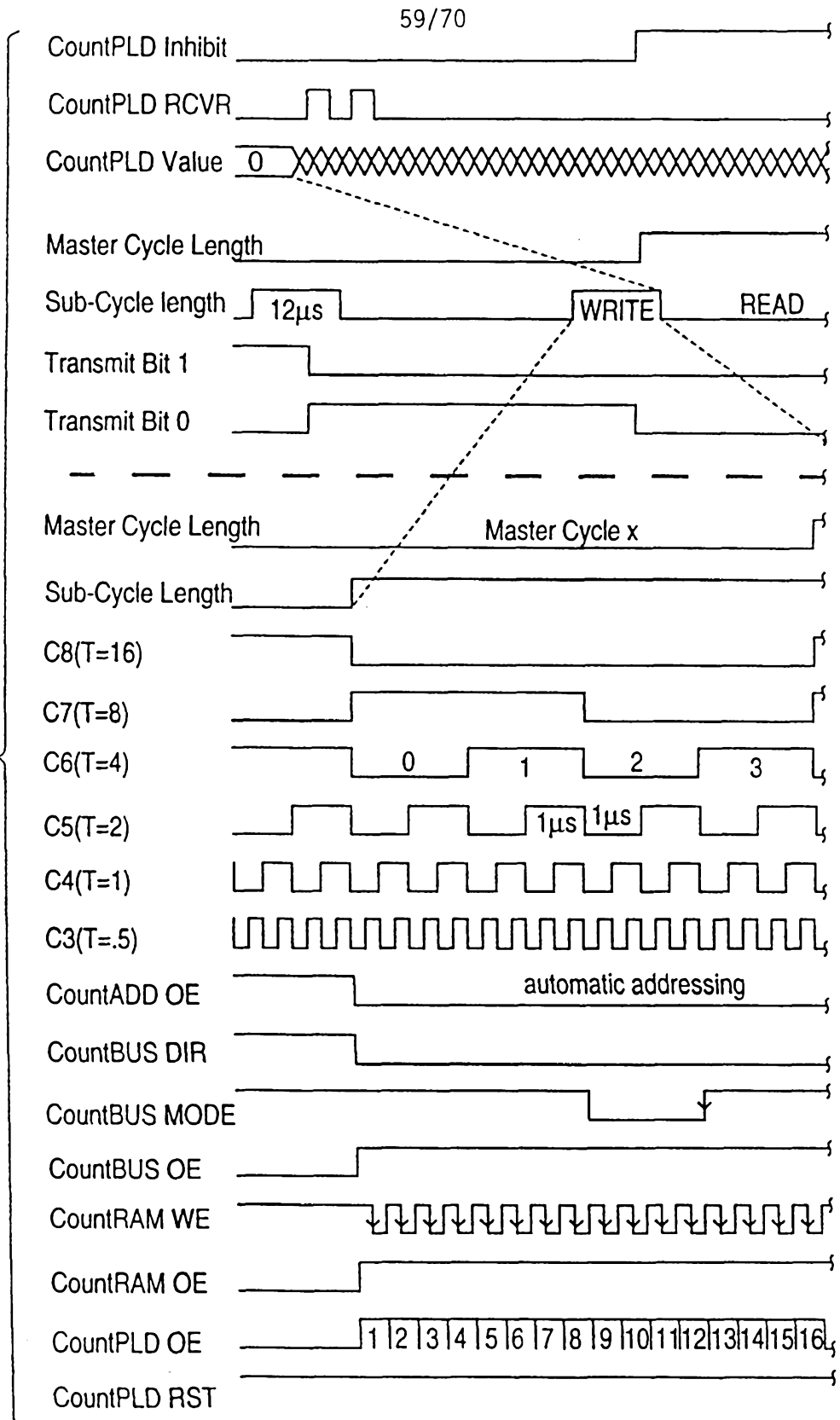

FIG.7 A.

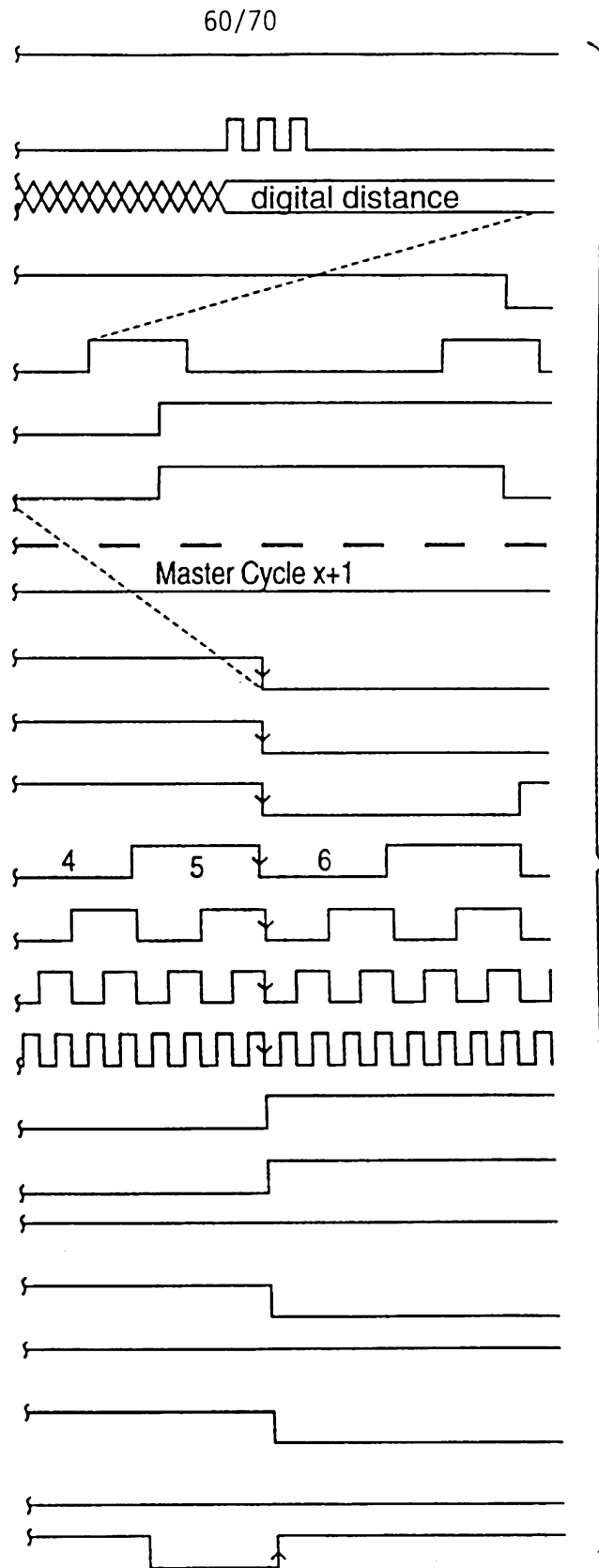

FIG. 7B.

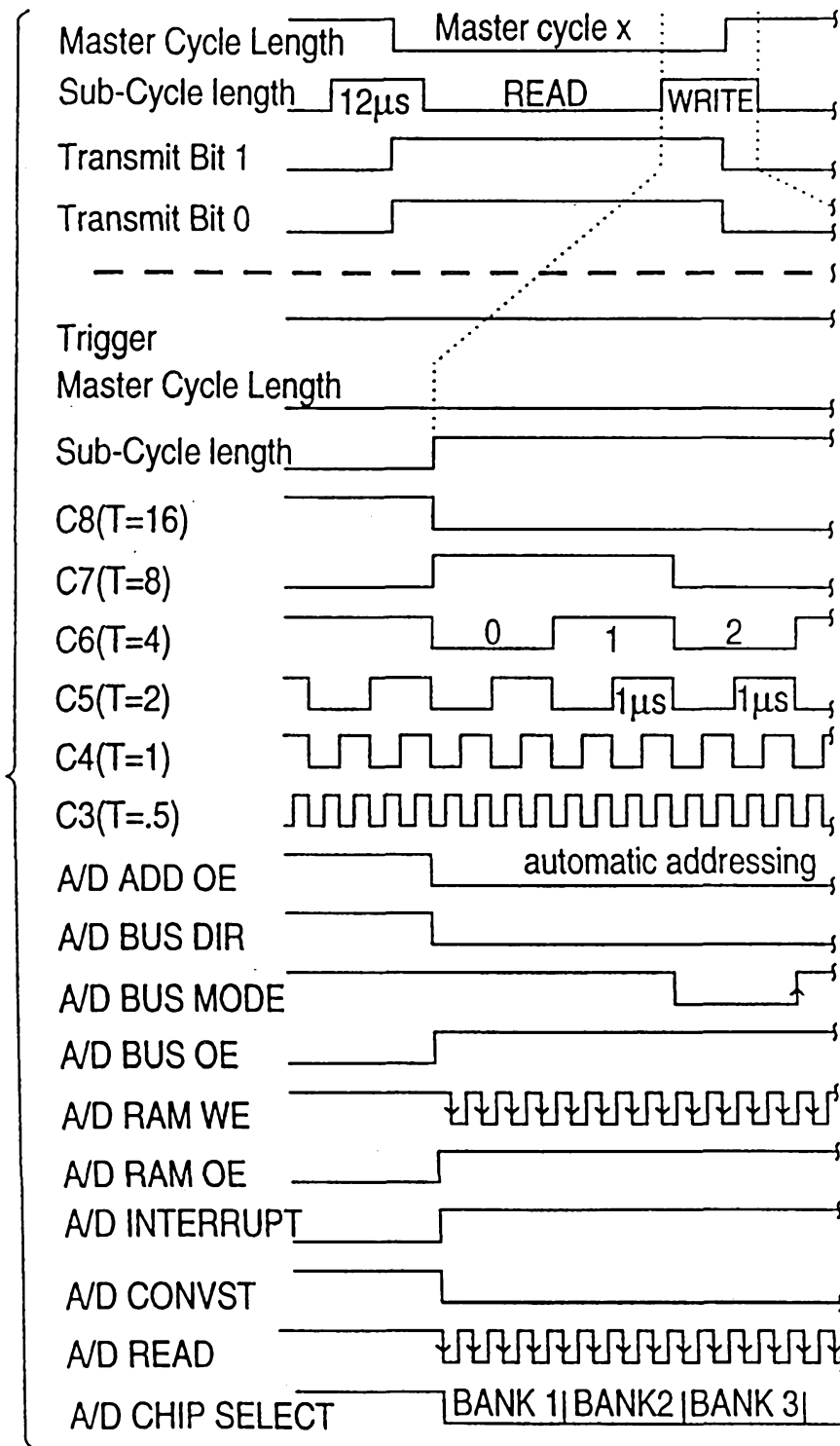

FIG. 8 A.

62/70

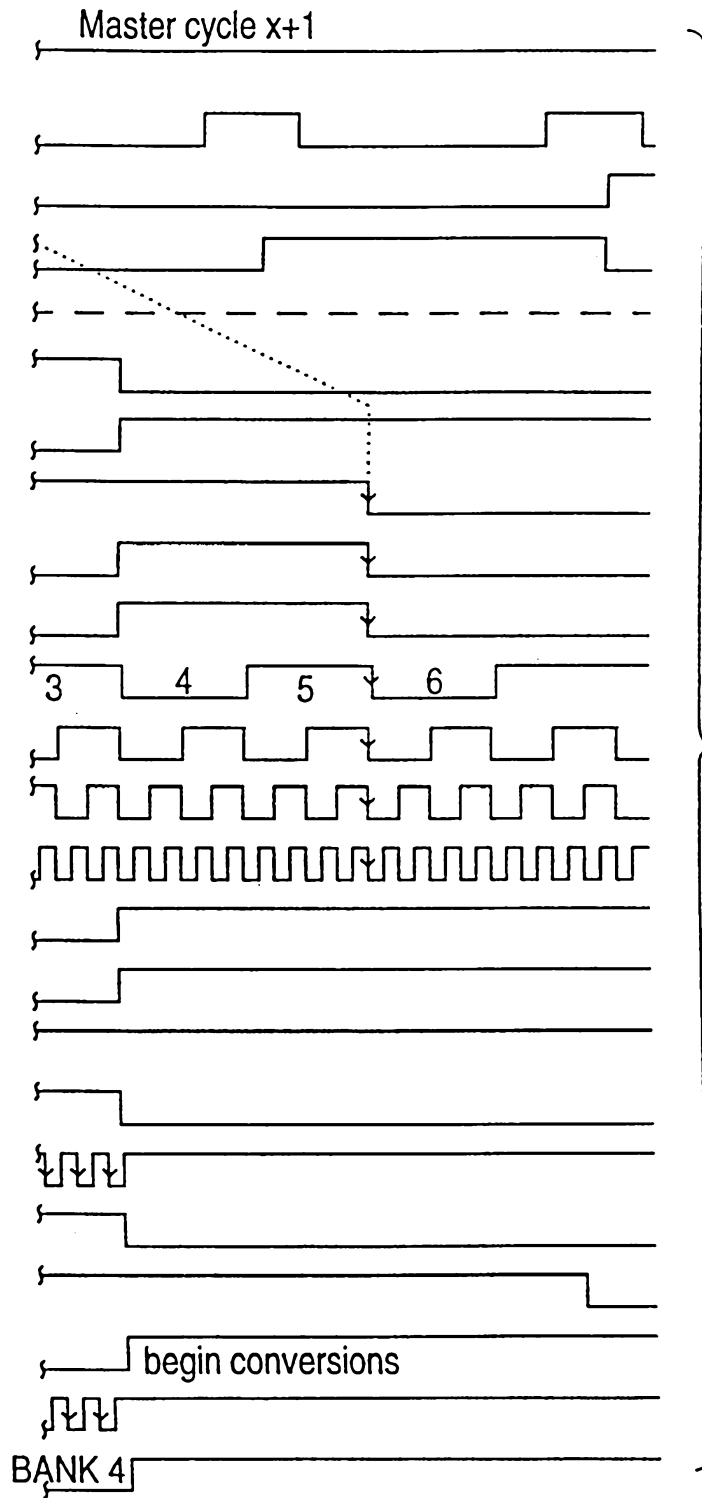

FIG.8B.

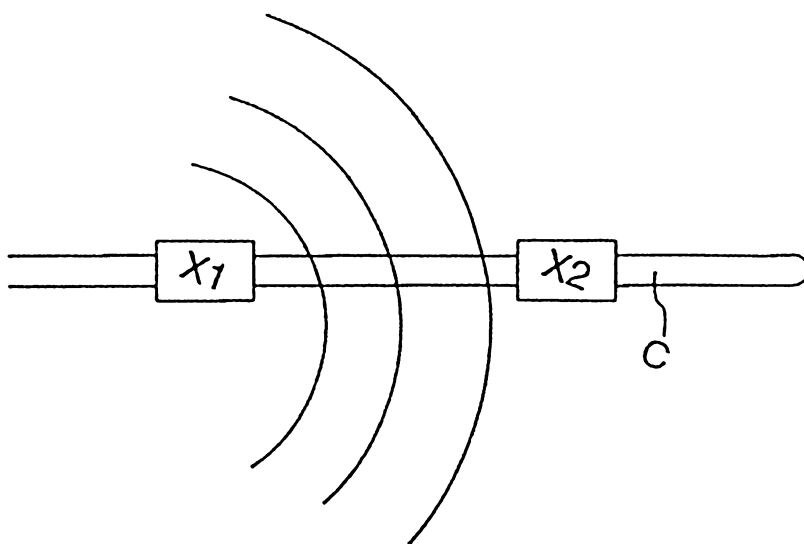

FIG.9.

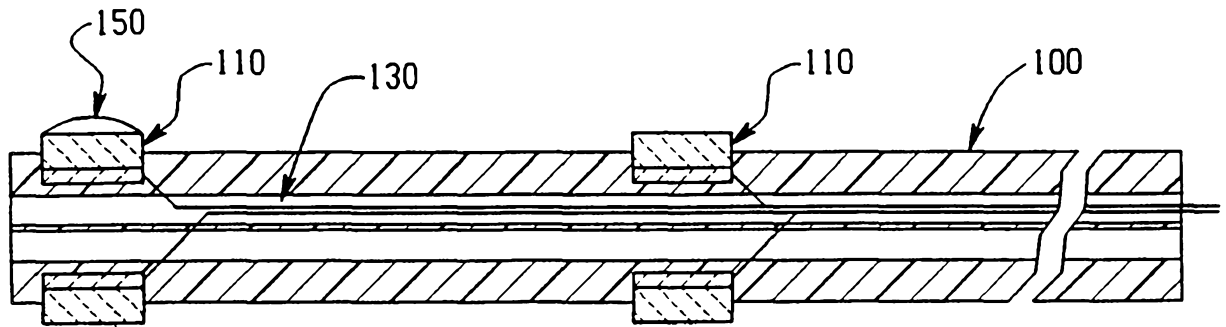

Fig. 10

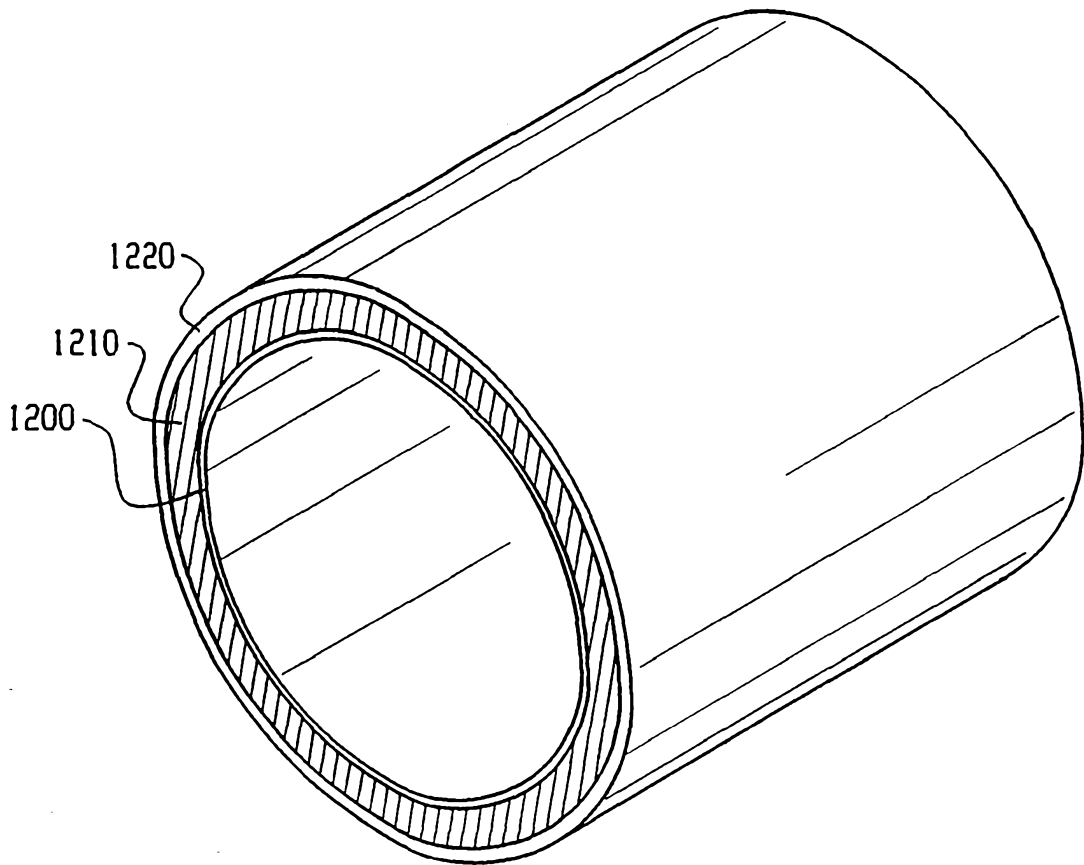

Fig. 12

PATH 2

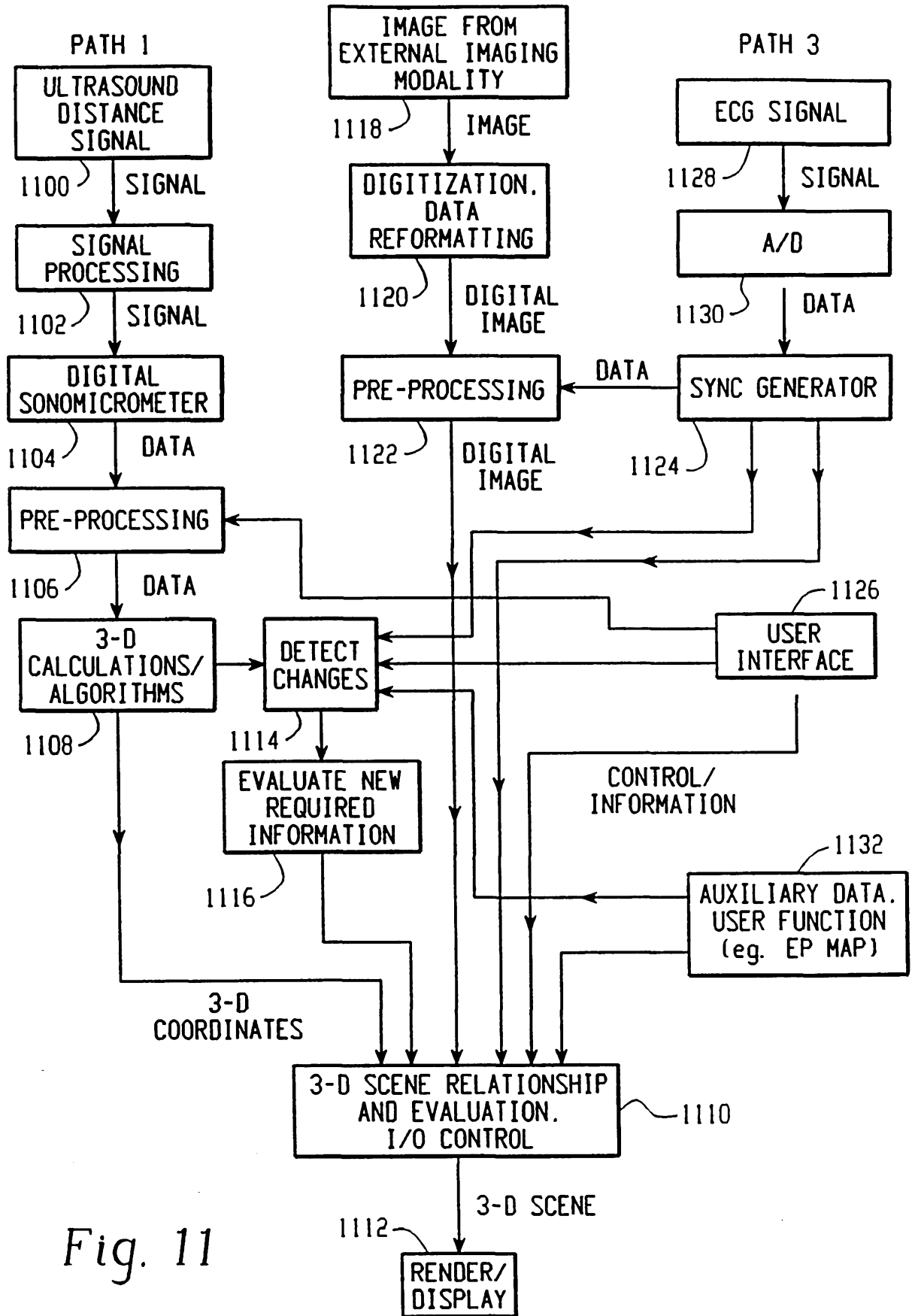

Fig. 11

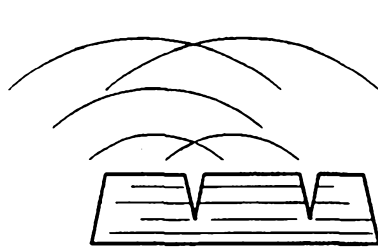

Fig. 13B

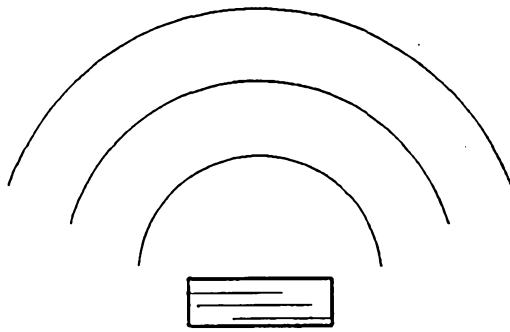

Fig. 13C

66/70

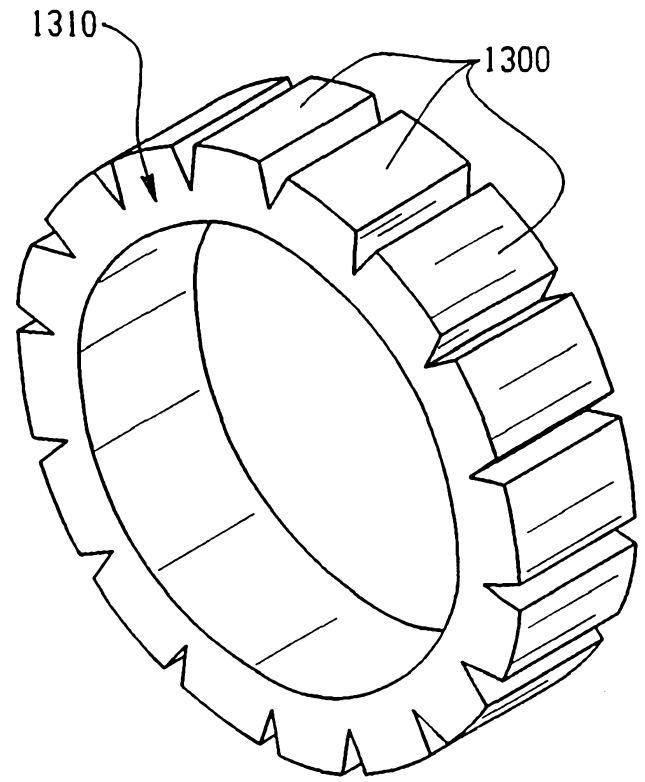

Fig. 13A

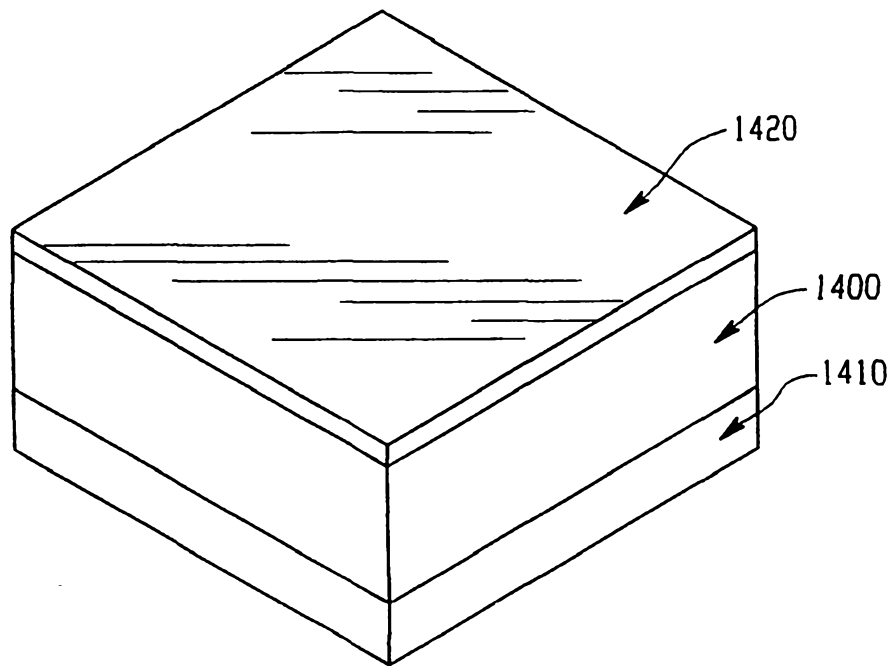

Fig. 14

67/70

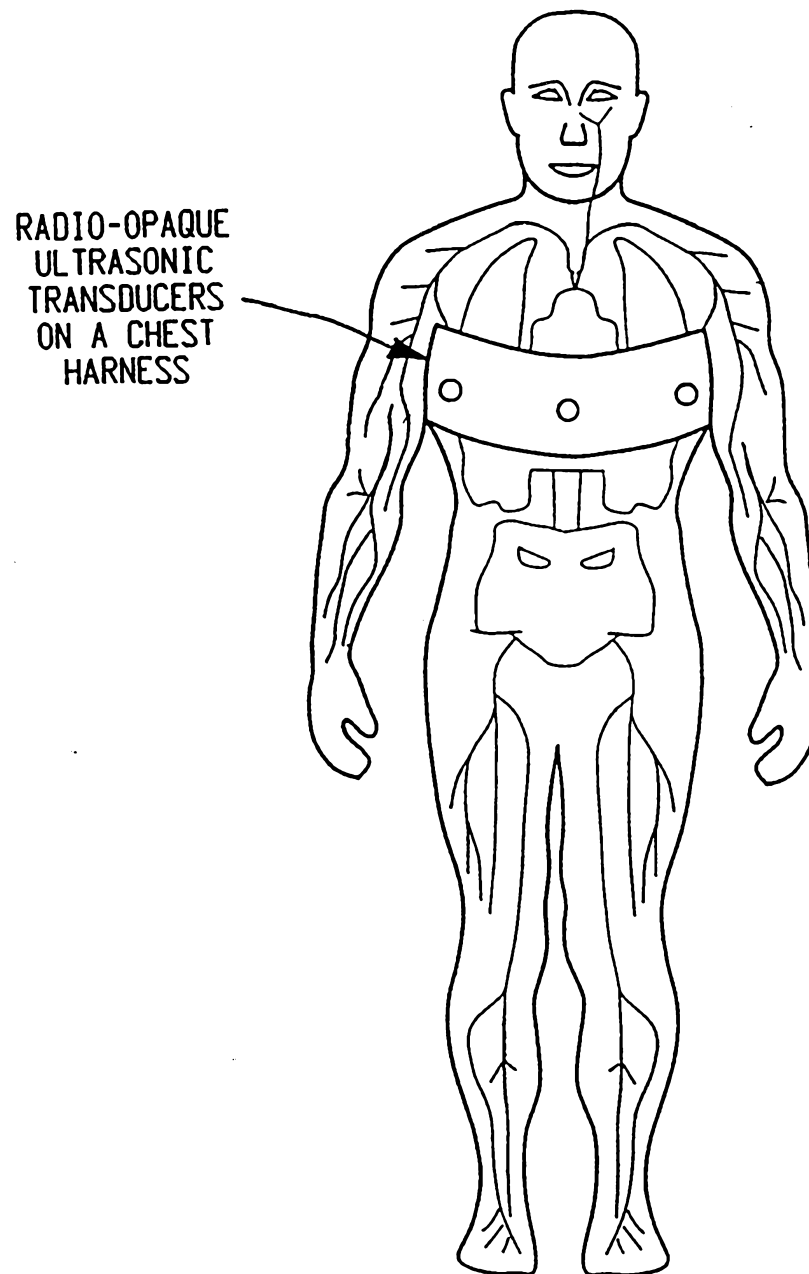

Fig. 15

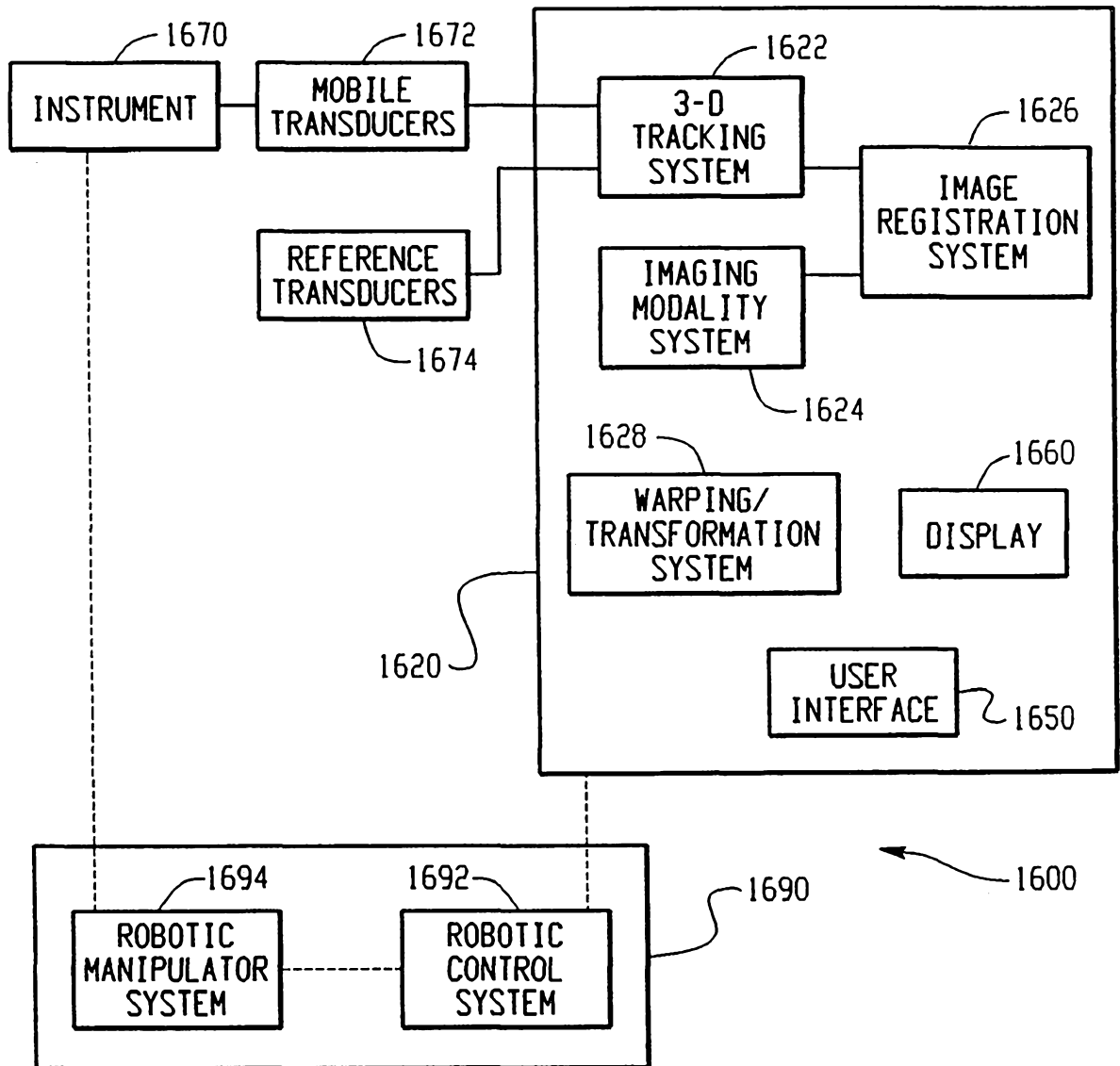

Fig. 16

69/70

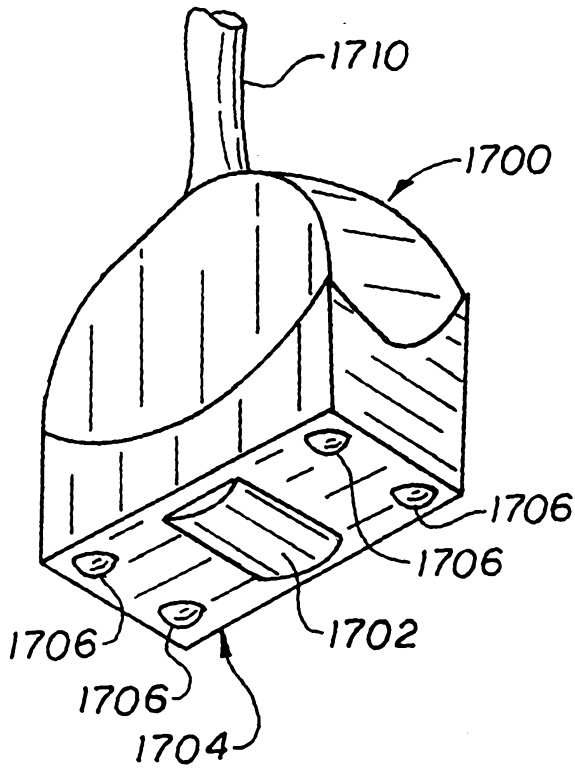

FIG. 17A

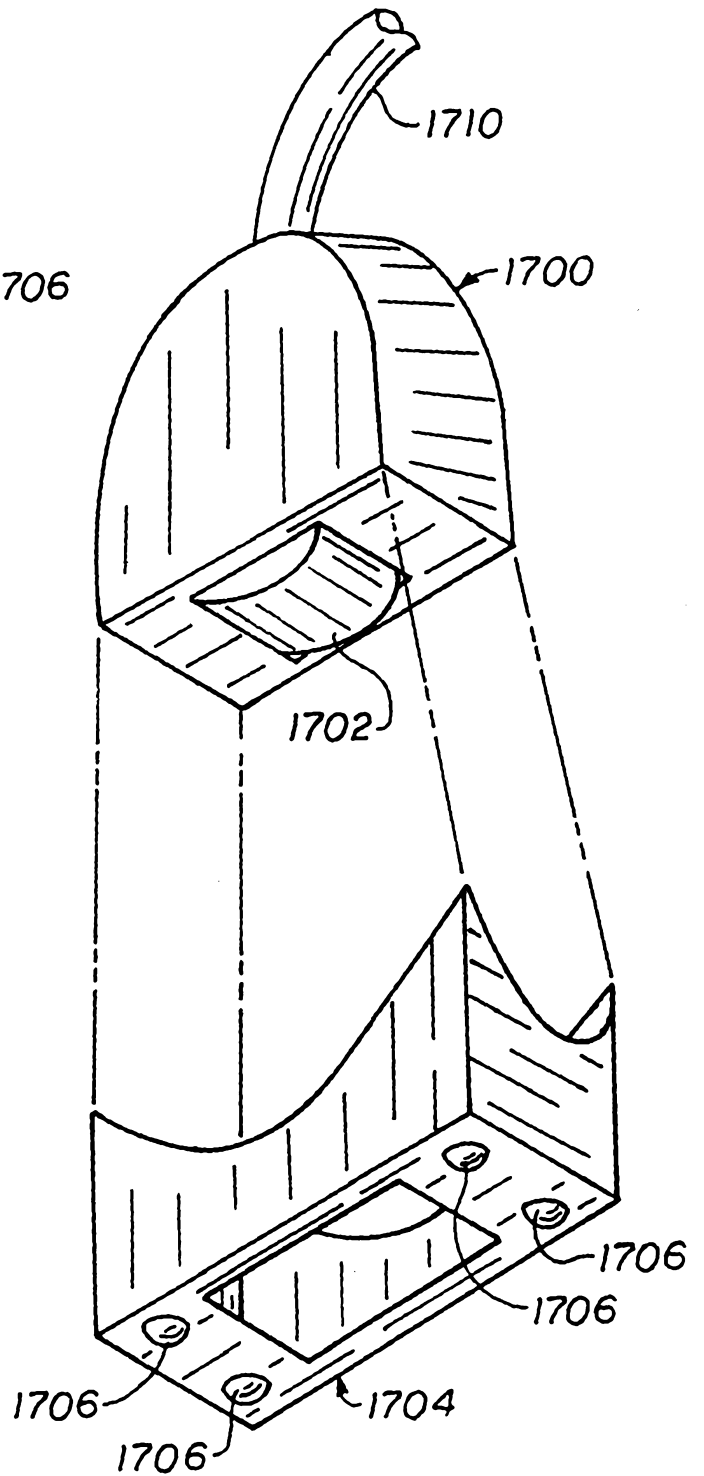

FIG. 17B

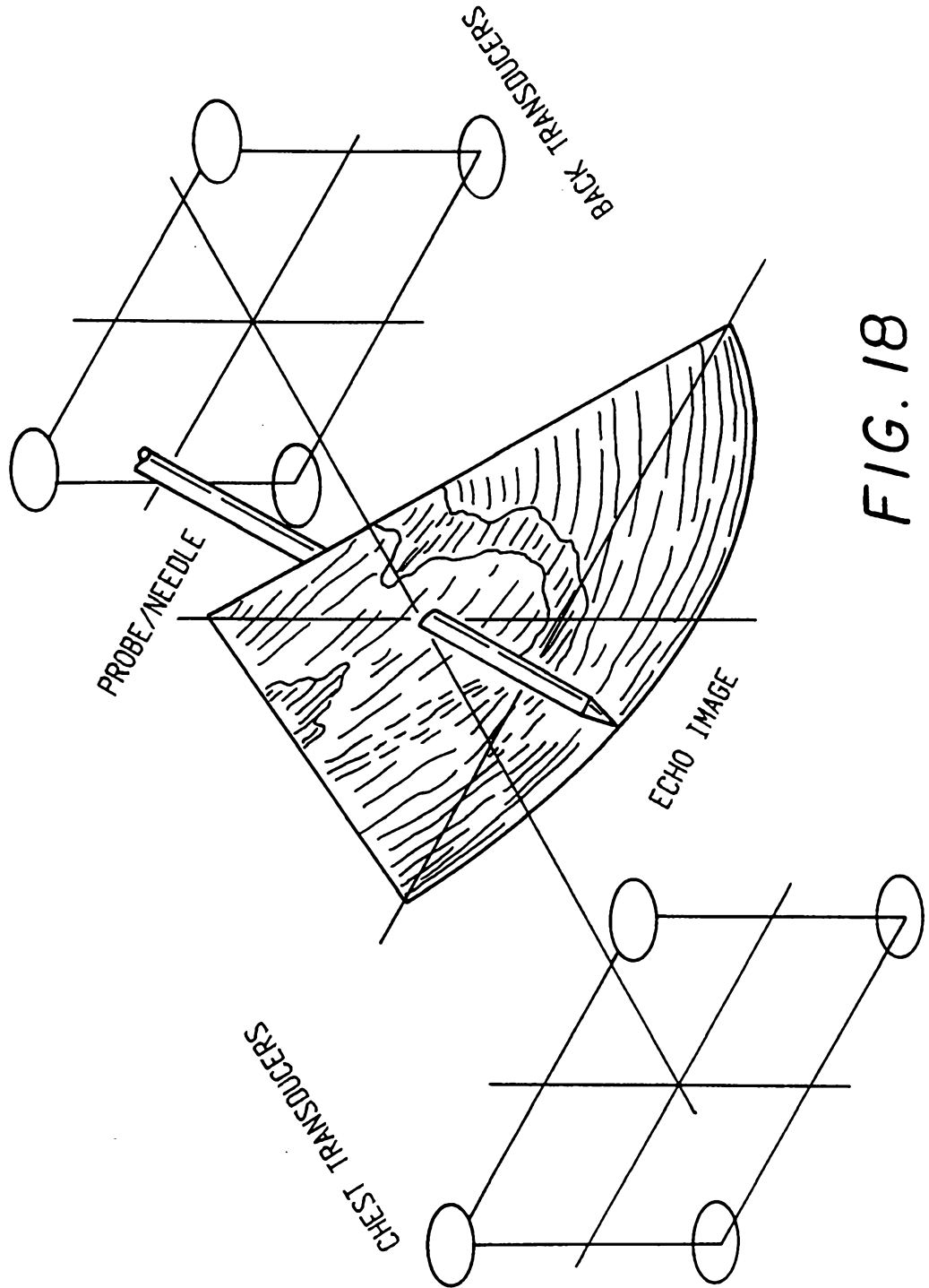

FIG. 18

INTERNATIONAL SEARCH REPORT

International Application No

PCT/IB 98/00534

A. CLASSIFICATION OF SUBJECT MATTER IPC 6 G01S5/22 G01S5/30 G01S5/18 A61B8/08				
According to International Patent Classification (IPC) or to both national classification and IPC				
B. FIELDS SEARCHED				
Minimum documentation searched (classification system followed by classification symbols) IPC 6 A61B G01S				
Documentation searched other than minimum documentation to the extent that such documents are included in the fields searched				
Electronic data base consulted during the international search (name of data base and, where practical, search terms used)				
C. DOCUMENTS CONSIDERED TO BE RELEVANT				
Category °	Citation of document, with indication, where appropriate, of the relevant passages	Relevant to claim No.		
X	US 5 515 853 A (GUBBELS ANDREW W ET AL) 14 May 1996 see the whole document	1-12, 18		
Y	---	13, 14, 19, 20		
X	US 5 398 691 A (BASHEIN GERARD ET AL) 21 March 1995 see the whole document	16		
X	US 5 042 486 A (ERMERT HELMUT ET AL) 27 August 1991 see the whole document	1		
Y	US 5 443 489 A (BEN-HAIM SHLOMO) 22 August 1995 see column 3, line 44 - line 62 --- -/--	19, 20		
<input checked="" type="checkbox"/> Further documents are listed in the continuation of box C.				
<input checked="" type="checkbox"/> Patent family members are listed in annex.				
° Special categories of cited documents :				
<table style="width: 100%; border: none;"> <tr> <td style="width: 50%; border: none; vertical-align: top;"> "A" document defining the general state of the art which is not considered to be of particular relevance "E" earlier document but published on or after the international filing date "L" document which may throw doubts on priority claim(s) or which is cited to establish the publication date of another citation or other special reason (as specified) "O" document referring to an oral disclosure, use, exhibition or other means "P" document published prior to the international filing date but later than the priority date claimed </td> <td style="width: 50%; border: none; vertical-align: top;"> "T" later document published after the international filing date or priority date and not in conflict with the application but cited to understand the principle or theory underlying the invention "X" document of particular relevance; the claimed invention cannot be considered novel or cannot be considered to involve an inventive step when the document is taken alone "Y" document of particular relevance; the claimed invention cannot be considered to involve an inventive step when the document is combined with one or more other such documents, such combination being obvious to a person skilled in the art. "&" document member of the same patent family </td> </tr> </table>			"A" document defining the general state of the art which is not considered to be of particular relevance "E" earlier document but published on or after the international filing date "L" document which may throw doubts on priority claim(s) or which is cited to establish the publication date of another citation or other special reason (as specified) "O" document referring to an oral disclosure, use, exhibition or other means "P" document published prior to the international filing date but later than the priority date claimed	"T" later document published after the international filing date or priority date and not in conflict with the application but cited to understand the principle or theory underlying the invention "X" document of particular relevance; the claimed invention cannot be considered novel or cannot be considered to involve an inventive step when the document is taken alone "Y" document of particular relevance; the claimed invention cannot be considered to involve an inventive step when the document is combined with one or more other such documents, such combination being obvious to a person skilled in the art. "&" document member of the same patent family
"A" document defining the general state of the art which is not considered to be of particular relevance "E" earlier document but published on or after the international filing date "L" document which may throw doubts on priority claim(s) or which is cited to establish the publication date of another citation or other special reason (as specified) "O" document referring to an oral disclosure, use, exhibition or other means "P" document published prior to the international filing date but later than the priority date claimed	"T" later document published after the international filing date or priority date and not in conflict with the application but cited to understand the principle or theory underlying the invention "X" document of particular relevance; the claimed invention cannot be considered novel or cannot be considered to involve an inventive step when the document is taken alone "Y" document of particular relevance; the claimed invention cannot be considered to involve an inventive step when the document is combined with one or more other such documents, such combination being obvious to a person skilled in the art. "&" document member of the same patent family			
Date of the actual completion of the international search <p style="text-align: center; font-size: 1.2em;">9 July 1998</p>		Date of mailing of the international search report <p style="text-align: center; font-size: 1.2em;">20/07/1998</p>		
Name and mailing address of the ISA European Patent Office, P.B. 5818 Patentlaan 2 NL - 2280 HV Rijswijk Tel. (+31-70) 340-2040, Tx. 31 651 epo nl, Fax: (+31-70) 340-3016		Authorized officer <p style="text-align: center; font-size: 1.2em;">Aivazian, D</p>		

INTERNATIONAL SEARCH REPORT

International Application No

PCT/IB 98/00534

C.(Continuation) DOCUMENTS CONSIDERED TO BE RELEVANT

Category °	Citation of document, with indication, where appropriate, of the relevant passages	Relevant to claim No.
Y	FR 2 709 392 A (LONDON HEALTH ASS) 3 March 1995 see page 7, line 1 - line 29 -----	13,14

INTERNATIONAL SEARCH REPORT

Information on patent family members

Intern. Patent Application No

PCT/IB 98/00534

Patent document cited in search report	Publication date	Patent family member(s)	Publication date
US 5515853 A	14-05-1996	AU 5140496 A	23-10-1996
		CA 2215508 A	10-10-1996
		WO 9631753 A	10-10-1996
US 5398691 A	21-03-1995	AU 7679894 A	22-03-1995
		WO 9506436 A	09-03-1995
US 5042486 A	27-08-1991	EP 0419729 A	03-04-1991
		JP 3133429 A	06-06-1991
US 5443489 A	22-08-1995	US 5391199 A	21-02-1995
		AU 692789 B	18-06-1998
		AU 7372394 A	20-02-1995
		CA 2144946 A	02-02-1995
		EP 0679068 A	02-11-1995
		JP 8504653 T	21-05-1996
		WO 9502995 A	02-02-1995
		US 5546951 A	20-08-1996
		US 5480422 A	02-01-1996
		US 5568809 A	29-10-1996
		US 5694945 A	09-12-1997
		US 5738096 A	14-04-1998
US 5713946 A	03-02-1998		
FR 2709392 A	03-03-1995	CA 2110148 A	25-06-1994
		DE 4344312 A	14-07-1994
		JP 6233765 A	23-08-1994
		US 5562095 A	08-10-1996