



- (51) International Patent Classification:  
A61B 17/80 (2006.01)
- (21) International Application Number:  
PCT/IB2012/053037
- (22) International Filing Date:  
15 June 2012 (15.06.2012)
- (25) Filing Language:  
English
- (26) Publication Language:  
English
- (30) Priority Data:  
61/497,972 17 June 2011 (17.06.2011) US
- (71) Applicant (for all designated States except US): **MIAMI DEVICE SOLUTIONS, LLC** [US/US]; 7620 NW 25 St. Unit 3, Miami, Florida 33122 (US).
- (72) Inventor; and
- (75) Inventor/Applicant (for US only): **BIEDERMANN, Markku** [DE/US]; 1111 Brickell Bay Dr, Apt. 3212, Miami, Florida 33131 (US).
- (74) Agents: **PRÜFER & PARTNER GBR** et al.; Sohnckestr. 12, 81479 München (DE).

- (81) Designated States (unless otherwise indicated, for every kind of national protection available): AE, AG, AL, AM, AO, AT, AU, AZ, BA, BB, BG, BH, BR, BW, BY, BZ, CA, CH, CL, CN, CO, CR, CU, CZ, DE, DK, DM, DO, DZ, EC, EE, EG, ES, FI, GB, GD, GE, GH, GM, GT, HN, HR, HU, ID, IL, IN, IS, JP, KE, KG, KM, KN, KP, KR, KZ, LA, LC, LK, LR, LS, LT, LU, LY, MA, MD, ME, MG, MK, MN, MW, MX, MY, MZ, NA, NG, NI, NO, NZ, OM, PE, PG, PH, PL, PT, QA, RO, RS, RU, RW, SC, SD, SE, SG, SK, SL, SM, ST, SV, SY, TH, TJ, TM, TN, TR, TT, TZ, UA, UG, US, UZ, VC, VN, ZA, ZM, ZW.
- (84) Designated States (unless otherwise indicated, for every kind of regional protection available): ARIPO (BW, GH, GM, KE, LR, LS, MW, MZ, NA, RW, SD, SL, SZ, TZ, UG, ZM, ZW), Eurasian (AM, AZ, BY, KG, KZ, RU, TJ, TM), European (AL, AT, BE, BG, CH, CY, CZ, DE, DK, EE, ES, FI, FR, GB, GR, HR, HU, IE, IS, IT, LT, LU, LV, MC, MK, MT, NL, NO, PL, PT, RO, RS, SE, SI, SK, SM, TR), OAPI (BF, BJ, CF, CG, CI, CM, GA, GN, GQ, GW, ML, MR, NE, SN, TD, TG).

**Declarations under Rule 4.17:**

— as to the applicant's entitlement to claim the priority of the earlier application (Rule 4.17(iii))

[Continued on next page]

(54) Title: MODULAR BONE PLATE AND MEMBER OF SUCH A MODULAR BONE PLATE

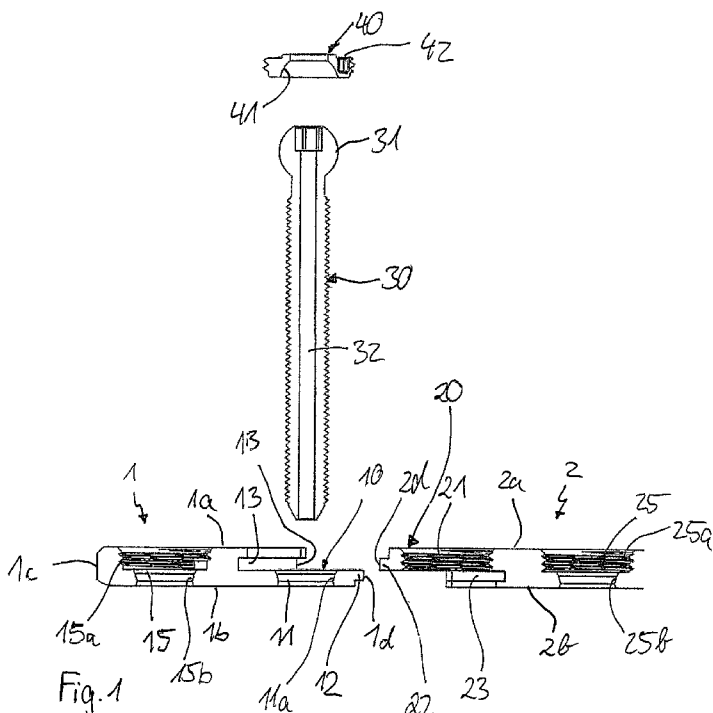

(57) Abstract: A member of a modular bone plate is provided, the member comprising a top surface defining a top plane; a bottom surface defining a bottom plane; a connection portion including a hole with a center axis that intersects the top plane and the bottom plane; wherein a first portion of the edge of the hole is provided with a projection forming a first free end of the member and wherein a second portion of the edge of the hole is provided with a groove that is configured to accommodate a projection of a connection portion of a second member of the modular bone plate. Furthermore, a modular bone plate having at least two such members is provided.

— *of inventorship (Rule 4.17(iv))*

**Published:**

— *with international search report (Art. 21(3))*

## Modular Bone Plate and Member of such a Modular Bone Plate

Cross-Reference to Related Applications

5 This application claims priority to and wholly incorporates by reference US provisional application number 61/497,972 to Biedermann filed on June 17, 2011 (Atty Docket No. MD 11-P28350US00).

10

Field of the Invention

The invention relates to a modular bone plate and to a member of such a modular bone plate.

Background of the Invention

15 Various shapes and types of bone plates to be used for osteosynthesis of fragmented bones and for stabilization of bones are known. The shape, size and type of a bone plate are usually adapted to the bones that shall be stabilized or immobilized. Hence, a large inventory of bone plates is typically necessary to be able to treat many different kinds of fractures or other defects at different locations.

20 There exist also modular bone plate systems that allow construction of a bone plate adapted to a specific application and to the individual patient by combining single members to form a whole bone plate. For example, US 2009/0082813 A1 describes a modular bone plating system including a plurality of bone plates including a male coupling portion, a female coupling portion and a shaft extending between the male coupling portion and the female coupling portion,  
25 wherein each of the male coupling portions of each of the plurality of bone plates is configured to couple with each of the female coupling portions of each of the other of the plurality of bone plates.

30 US 5,484,439 describes a modular femur fixation device. The device comprises an upper side plate with a widened head and an angled barrel, and a lower side plate adapted to be engaged with the upper side plate in a tongue and groove configuration.

### Summary of the Invention

It is the object of the invention to provide a modular bone plate and a member of such a modular bone plate that is simplified in terms of handling and manufacturing while exhibiting a strength that is comparable to single part bone plates.

5

The object and further developments are addressed by the various embodiments of the invention .

The modular bone plate is assembled by connecting at least two members of the modular bone plate at their respective connection portions such that the projection of the connection portion of a first member is introduced into the groove of a connection portion of the second member. In the assembled configuration the holes of both connection portions are arranged concentrically, on top of each other. The assembly is quickly and easily performed and the resulting construct is prevented from disassembling by the form locking connection between the projection and the groove. Hence, the surgeon can take the pre-assembled bone plate and place it on to the bone parts or fragments or bones that need to be connected or stabilized without using further elements or tools for keeping together the bone plate members.

10  
15

Due to modularity, lower inventory may be required and it may be possible to reduce the bone plate set price. Also, custom plates may be assembled to meet specific patient needs, on a case-by-case basis. A great variety of modular bone plate members can be provided and the members can be combined in various manners. For example, the modular bone plate can be used with bone anchors with spherical heads that allow for an angled configuration of the bone anchor relative to the bone plate, with set screws, with plugs to close the holes etc. or with combinations thereof. This opens a great field of clinical applications. Because of this easy and secure assembly and the resulting strong construct, the surgeon can select different modular pieces and assemble a custom bone plate directly in the operating room, used for a specific application.

20  
25

Modifications of the design of the modular bone plate member allow the surgeon to connect the members to form an angled configuration with a variable angle that can be selected by the surgeon. Further modifications allow for modular bone plate members of different thicknesses to be combined to form bone plate constructs of variable thickness.”

30

### Brief Description of the Drawings

Further features and advantages will become apparent from the description of embodiments and  
5 means of the accompanying drawings.

In the drawings:

- 10 Fig. 1: shows a schematic exploded cross-sectional view of a first embodiment of the modular bone plate with a bone anchor and a cap to secure the bone anchor.
- Fig. 2a): shows a perspective exploded view of the modular bone plate according to the first embodiment.
- 15 Fig. 2b): shows a perspective view from the bottom of the first plate member of the modular bone plate of Fig. 1.
- Fig. 3: shows a perspective exploded view of the modular bone plate according to the first embodiment wherein the bone plate members have been connected.
- 20 Fig. 4: shows a cross-sectional view of the modular bone plate according to the first embodiment wherein the bone plate members have been connected and the bone anchor and the cap have been inserted.
- 25 Fig. 5: shows an enlarged cross-sectional view of the modular bone plate according to the first embodiment with an inserted plug to close the hole.
- Fig. 6: shows a perspective view from the top of a connector member of the modular bone plate according to the first embodiment.
- 30 Fig. 7: shows a perspective view from the bottom of the connector member according to Fig. 6.

- Fig. 8: shows a schematic cross-sectional view of the connector member according to Fig. 6, wherein the cross-section is taken along line A-A in Fig. 6.
- 5 Fig. 9: shows a perspective view from the top of a second member of the modular bone plate according to the first embodiment.
- Fig. 10: shows a perspective view from the top of a third member of the modular bone plate according to the first embodiment.
- 10 Fig. 11: shows a perspective exploded view of the modular bone plate according a modification of the first embodiment.
- Fig. 12: shows a schematic cross-sectional view of the assembled modular bone plate according to Fig. 11.
- 15 Fig. 13: shows a perspective partially exploded view of a further modification of the modular bone plate according to the first embodiment.
- 20 Fig. 14: shows a schematic cross-sectional view of the assembled modular bone plate according to Fig. 13.
- Fig. 15: shows an exploded perspective view of a further modification of the modular bone plate according to the first embodiment.
- 25 Fig. 16: shows a schematic cross-sectional view of the modular bone plate of Fig. 15 in an assembled state.
- Fig. 17: shows an exploded perspective view of a further modification of the modular bone plate according to the first embodiment.
- 30

Fig. 18: shows a perspective view from the top of the modular bone plate of Fig. 17 in an assembled state.

5 Fig. 19a) to c): shows a top view of a modular bone plate according to a second embodiment in different angular positions of the bone plate members relative to each other.

Fig. 20a) to e): shows a perspective view of the modular bone plate according to a modification of the second embodiment in different angular relationships of the bone plate members.

10

Fig. 21: shows a third embodiment of the modular bone plate in side view.

Fig. 22: shows a perspective view from the top of a member of the bone plate according to the third embodiment.

15

Fig. 23: shows a further modification of the modular bone plate according to the third embodiment.

#### Detailed Description of the Invention

20 As shown in Figs. 1 to 4, the modular bone plate according to the first embodiment includes at least a first member 1 and a second member 2 that are to be connected to each other. The first member is shaped in the form of an elongated plate and comprises a top surface 1a and a bottom surface 1b that are substantially parallel to each other and define the height of the first member 1. The first member 1 further has a first free end 1c and a second free end 1d opposite  
25 to the first free end 1c. Furthermore, the first member 1 comprises a connection portion 10 that serves for connecting the first member 1 to the second member 2. The connection portion 10 extends from the second free end 1d to a distance therefrom in a longitudinal direction of the first member 1. It comprises a hole 11 that is a through-hole as can be seen in particular in Fig. 2a) and 2b). The edge of the hole 11 that extends to the second free end 1d is substantially semi  
30 circular and comprises a projection 12 that forms the free end 1d. The projection 12 is located at a distance, in particular a small distance, from the bottom surface 1b at substantially the middle of the height between the top surface 1a and the bottom surface 1b. Further, the connection por-

tion 10 comprises a recess by means of which an upper portion adjacent the top surface 1a of the first member is cut out. The recess extends into the first member to a distance from the edge of the hole 11 so as to form a groove 13. The groove 13 has a distance from the top surface 1a that corresponds substantially to the distance of the projection 12 from the bottom surface 1b.

5 The size and the shape of the grooves correspond to the size and shape of the projection 12. Hence, the groove 13 is semi-circular. At both free ends of the groove 13 a substantially rectangular recess is provided, as can be seen in particular in Figs. 2a and 2b.

10 The hole 11 comprises a section 11a that is shaped as a segment of a sphere with the smaller diameter oriented towards the bottom surface 1b. This hollow spherically-shaped portion 11a serves as a seat for a spherically-shaped head 31 of a bone anchor 30.

15 The first member 1 comprises a further hole 15 extending from the top surface 1a to the bottom surface 1b. The hole 15 has a first portion 15a that is at least partially threaded and is configured to receive a locking cap 40 to be placed onto a spherical head of another bone anchor. The hole 15 further comprises a spherically-shaped portion 15b for receiving the spherical head of the bone anchor.

20 The second member 2 is also formed as an elongated plate and comprises a top surface 2a and a bottom surface 2b. The distance between the top surface 2a and the bottom surface 2b defines the height of the member 2 that is identical to the height of the plate member 1. The second member 2 has a first free end (not shown in Fig. 1) and an opposite second free end 2d.

25 Similar to the first member 1, the second member 2 has a connection portion 20 that is to be connected to the connection portion 10 of the first member 1. The connection portion 20 comprises a hole 21. The edge of the hole 21 extending to the second free end 2d comprises a projection 22 that is semi-circular and sized and arranged so that it fits into the groove 13 of the first connection portion 10. Further, the second member 2 comprises a recess that cuts out a portion from the bottom surface 1b up to substantially the middle of the height of the member 2 and extends to the edge of the hole in a direction to the first end 2c so as to form a groove 23.

30 The groove 23 is sized and arranged to receive the projection 12 of the first member 1. The hole



21 is at least partially threaded and configured to receive the cap 40 that secures the head of the bone anchor 30.

5 The second member 2 comprises at least a second hole 25 with an at least partially threaded portion 25a adjacent the top surface 2a and a spherically-shaped portion 25b in the lower part to receive a spherical head of another bone anchor.

10 In one embodiment, the modular bone plate includes a third piece, such as a cap or screw, for example, to connect and/or hold (compress and/or lock) the two members (the first member 1 and the second member 2) together. The third piece functions to maintain the assembly of the plate, after it is placed on the bone.

15 The assembly of the modular bone plate will now be described with reference to Figs. 3 and 4. To connect the members 1 and 2 to each other, the members are oriented with their second free ends 1d, 2d facing towards each other as shown in Fig. 1. Then, the projection 22 of the second member is inserted into the groove 13 of the first member. Because of the substantially symmetrical design, the projection 12 of the first member is simultaneously introduced into the groove 23 of the second member 2. When the projections are fully introduced into the grooves, they abut against the inner wall of the grooves and the holes 11 and 21 overlap. The bottom  
20 surface 1b of the first member and the bottom surface 2b of the second member are substantially flush as can be seen in particular in Fig. 4. Due to the recess resulting from groove 13 of the first member, the side faces of the plate members are substantially flush as shown in Fig. 3. It is possible to dimension the groove 13 of the first member substantially semi-circular so that the side faces of the plate members are substantially flush as shown in Fig. 3.

25 The dimensions of the connection portions are such that once connected, the projections fit tightly into the grooves such that the assembled bone plate can be placed onto the bone without the members falling apart. Once the modular bone plate has been placed onto the bone, the bone anchor 30 can be inserted so that the spherical head 31 is seated in the spherically-shaped portion 15b of the hole 11. The bone anchor 30 may have a coaxial through hole 32 for injection of  
30 substances or bone cement and/or for guiding through a guide wire that may be used to place the bone anchor into the bone. The bone anchor 30 may assume different angular positions with

respect to the plate because the head 31 is accommodated in the spherically-shaped portion 15b in the manner of a ball and socket joint.

5 The locking cap 40 has a threaded outer surface 40a and a spherically-shaped recess 41 oriented towards the spherical head 31 of the bone anchor 30. On the opposite side, the cap comprises a plurality of pockets 42 for engagement with a driver. The locking cap 40 is screwed into the at least partially threaded hole 21 to secure the bone anchor in the plate and prevent backing out of the bone anchor.

10 The connection between the connection portions provides a substantially uniform load distribution between the two plate members.

In Fig. 5 the first member 1 and the second member 2 are assembled and the holes 11, 21 are closed by a closure plug 45 that is similar to the locking cap 40 in that it has a threaded section 15 46 cooperating with the threaded hole 21 and pockets 47 for a driver. In the lower part, the closure plug 45 has a spherically-shaped section 48 that fits into the spherically-shaped portion 15b of the hole 11. By means of this, two members can be connected without using a bone anchor.

Figs. 6 to 8 show a further member of the modular bone plate. The member 3 is a connector 20 member that has a top surface 3a, a bottom surface 3b, a first free end 3c and a second free end 3d. The connector piece comprises two connection portions 10, 20. The first connection portion 10 is arranged at the first free end 3c and the second connection portion 20 is arranged at the second free end 3d. The first connection portion 10 is identical to the first connection portion 10 of the first member 1 and the second connection portion 20 is identical to the second connection 25 portion 20 of the second member 2 described above. Therefore, all details of the first and second connection portion 10, 20 are indicated with the same reference numerals as for the first member 1 and the second member 2. The description thereof will not be repeated.

The connector member 3 serves as an intermediate member that may connect to other members 30 of the type of the first member 1 and the second member 2. The distance between the first and the second connection portion may vary so that a plurality of connector pieces in the form of the third member 3 can be provided that have different length.

Fig. 9 shows a modified third member 3' that differs from the third member 3 shown in Figs. 6 to 8 in that a further hole 27 is provided between the first connection portion 10 and the second connection portion 20. The hole 27 has an at least partially threaded portion 27a adjacent the top surface 3a and a spherically-shaped portion 27b for accommodating the spherical head 31 of a bone anchor that is similar to the bone anchor 30. It may be envisaged that several additional holes can be provided between the first connection portion 10 and the second connection portion 20.

Fig. 10 shows an end member 2', similar to the first member 1. Preferably, the end member has a rounded free end 2c.

Figs. 11 and 12 show a further modification of the modular bone plate according to the first embodiment. The plate members 1', 2'' differ from the plate members 1 and 2' described before in the connection portion 10', 20', respectively. The connection portions 10', 20' each have a threaded hole of the same size. When the plate members 1', 2'' are connected to each other a set screw 50 can be screwed-in to connect the plate members. All details that are identical to that of the previous embodiments are indicated with the same reference numerals and the description thereof is not repeated.

Figs. 13 and 14 show a further modification of the modular bone plate shown in Figs. 11 and 12. The plate members 1'' and 2''' comprise connection portions 10'' and 20'''. The holes 11'' and 21'' are threadless and comprise recesses 11c, 21c for accommodating a flange 52a of nut 52 and a flange 53a of a screw 53, respectively. The nut 52 and the screw 53 cooperate to fix the connection as shown in Fig. 14.

Figs. 15 and 16 show a further modification of the plate members and the connection thereof. The plate member 1' is substantially identical to the first plate member 1' of Figs. 11 and 12. The plate member 2''' corresponds substantially to the plate member 2''' of Figs. 13 and 14. Hence, a screw 54 with a flange 54a can be used to connect the plate members together as shown in Fig. 16.

A further modification of the first embodiment is shown in Figs. 17 and 18. The first plate member 100 has a first connection portion 101 and the second plate member 200 has a second connection portion 201. The first connection portion 101 and the second connection portion 201 have a greater width than in the previous embodiments. The width may be greater than the remainder of the first member 100 and the second member 200. However, dependent on the application, the width may also be the same over the length of the plate member. On both sides of the projection 12 in the width direction, there is a groove 103 that extends substantially perpendicular to the length direction of the plate member 100. The second plate member 200 has a corresponding projection 203 extending perpendicular to the length direction of the plate member 200 that cooperates with the groove 103. Hence, the groove 13 is enlarged by the groove 103 and the projection 23 is enlarged by the projection 203. As shown in Fig. 18 this provides larger contact area of the two plate members 100, 200 and simultaneously a greater width of the bone plate. This provides a strengthened connection.

Fig. 19 shows a still further embodiment of the modular bone plate. The first plate member 1000 and the second plate member 2000 can assume an angled position with respect to each other as shown in Figs. 19a) and 19c). To achieve this, first plate member 1000 has a recess 1114 at both ends of the groove 13 so that, when the second plate member 2000 is inserted with its projection 22 into the groove 13, there is a gap between the end of the groove 13 and the second plate member 2000 as can be seen in particular in Fig. 19b). This allows for pivoting of the second plate member 2000 with respect to the first plate member 1000 around the axes of the holes 11, 21 to a certain angle that may be up to around  $10^\circ$  or  $15^\circ$  (soft angle).

In a still further embodiment shown in Figs. 20a) to 20e) the groove 13 in the first plate member 1000 is provided at a rotated position with respect to the axes of the holes 11, 21. Positions between around  $15^\circ$ , shown in Fig. 20b) and  $90^\circ$  in Fig. 20e) are possible (hard angle). Because the groove is part of the first connection member 1000 the angle is fixed and can not be changed as in the embodiment of Fig. 19. Those having ordinary skill in the art will appreciate that a combination of hard and soft angles may be utilized, according to the above.

In a further embodiment shown in Figs. 21 to 23 a modular bone plate can have different thicknesses along the length of the modular bone plate. To achieve this, a connector piece 300 as

shown in Fig. 22 is provided that has a first portion 300a that comprises the first connection portion 10 and a second portion 300b that comprises the second connection portion 20. The bottom surface of portions 300a and 300b is on the same level. However, the thickness of the portion 300a is greater than the thickness of the portion 300b. Hence, the connector piece can be used to connect plate members having different thicknesses. Fig. 21 shows a cascaded configuration wherein the thickness is increasing from one end to the other end of the modular bone plate in steps and Fig. 23 shows an application wherein the thickness is greatest in the center part of the bone plate.

10 Referring now to Figs. 24-26, schematic diagrams of a further embodiment are shown in which longer flanges or tongues 61 and 62 are provided. The longer flanges may enable more stable connections between members 1 and 2, due to better distribution of forces, for example. In Fig. 26, a locking cap 63 is shown for fastening together members 1 and 2. The embodiment described with respect to Figs. 24-26 may otherwise function similarly to earlier-described em-  
15 bodiments.

The members of the modular bone plate can be made of any bio-compatible material. Preferably, the members are made of titanium, stainless steel, bio-compatible alloys or bio-compatible plastic materials, such as, for example PEEK (polyetheretherketone). The members can be  
20 made all of the same material or can be made of different materials so that the modular bone plate has different materials in one portion thereof compared to another portion.

It should be clear from the above that plate members can be designed in many configurations and are not limited to the specific embodiments shown above. For example, plate members can  
25 have less or more holes as shown. The contour of the plate members may vary. The holes may be threaded and provided with spherically-shaped sections for an angled insertion of the bone anchor or may have only threads for straight and fixed angle insertion of the bone anchor. The holes may even have an axis that is not perpendicular to the top and the bottom surface but includes an angle with the top and the bottom surface. The features of all the embodiments de-  
30 scribed above can be combined among each other to provide a specific plate member needed for a specific application. Therefore, the necessary inventory can be reduced.

By means of the modularity and the simplicity of handling while ensuring sufficient strength, the field of applications of the modular bone plate is enlarged. Plate members can be produced in all sizes so that the modular bone plate can be used in pediatric orthopedics, cervical spine surgery, hand surgery, long bone treatment and many other applications.

## Claims

1. A member of a modular bone plate, the member comprising  
5 a top surface defining a top plane;  
a bottom surface defining a bottom plane;  
a connection portion including a hole with a center axis that intersects the top plane and  
the bottom plane;  
wherein a first portion of the edge of the hole is provided with a projection forming a  
10 first free end of the member and  
wherein a second portion of the edge of the hole is provided with a groove that is con-  
figured to accommodate a projection of a connection portion of a second member of the  
modular bone plate.
- 15 2. The member of claim 1, wherein the projection is at least partially circular.
3. The member of claim 1 or 2, wherein the groove is at least partially circular.
4. The member of one of claims 1 to 3, wherein the projection and the groove are arranged  
20 on opposite sides from the hole.
5. The member of one of claims 1 to 4, wherein the projection extends around approxi-  
mately half of the circumference of the hole.
- 25 6. The member of one of claims 1 to 5, wherein the groove extends around approximately  
half of the circumference of the hole.
7. The member of one of claims 1 to 6, wherein the length of the groove in a circumferen-  
tial direction corresponds substantially to the length of the projection in a circumferen-  
30 tial direction.

8. The member of one of claims 1 to 7, wherein the arrangement of the projection and the groove is such that the distance of the projection to the bottom surface in a direction perpendicular to the bottom surface is smaller than the distance of the groove to the bottom surface.
- 5
9. The member of one of claims 1 to 7, wherein the arrangement of the projection and the groove is such that the distance of the projection to the top surface in a direction perpendicular to the top surface is smaller than the distance of the groove to the top surface.
- 10
10. The member of one of claims 1 to 7, wherein the arrangement of the projection and the groove is such that the distance of the projection to the top surface in a direction perpendicular to the bottom surface is larger than the distance of the groove to the bottom surface.
11. The member of one of claims 1 to 10, wherein the hole is at least partially threaded.
- 15
12. The member of one of claims 1 to 11, wherein the hole comprises a spherically-shaped portion providing a seat for a spherical head of a bone anchor.
13. The member of claim 12, wherein the spherically-shaped portion is arranged between a threaded portion and the bottom surface.
- 20
14. The member of one of claims 1 to 13, wherein the member comprises at least a further hole extending from the top surface to the bottom surface.
- 25
15. The member of claim 14, wherein the at least one further hole is at least partially threaded and/or has a spherically-shaped portion providing a seat for a spherical head of a bone anchor.
- 30
16. The member of one of claims 1 to 15, wherein the member comprises a further connection portion including a hole with a center axis that intersects the top plane and the bottom plane;



wherein a first portion of the edge of the hole is provided with a projection forming a second free end of the member opposite to the first free end and wherein a second portion of the edge of the hole is provided with a groove that is configured to accommodate a projection of a connection portion of a second member of the modular bone plate.

5

17. A modular bone plate including at least a first member and a second member, wherein each member is a member according to one of claims 1 to 16; wherein the first member is configured to be coupled to the second member in that the projection of the first member is inserted into the groove of the second member.

10

18. The modular bone plate of claim 17, wherein the bottom surface of the first member is flush with the bottom surface of the second member when the first member and the second member are coupled.

15

19. The modular bone plate of claim 17 or 18, wherein the first member and the second member include an angle with respect to each other.

20

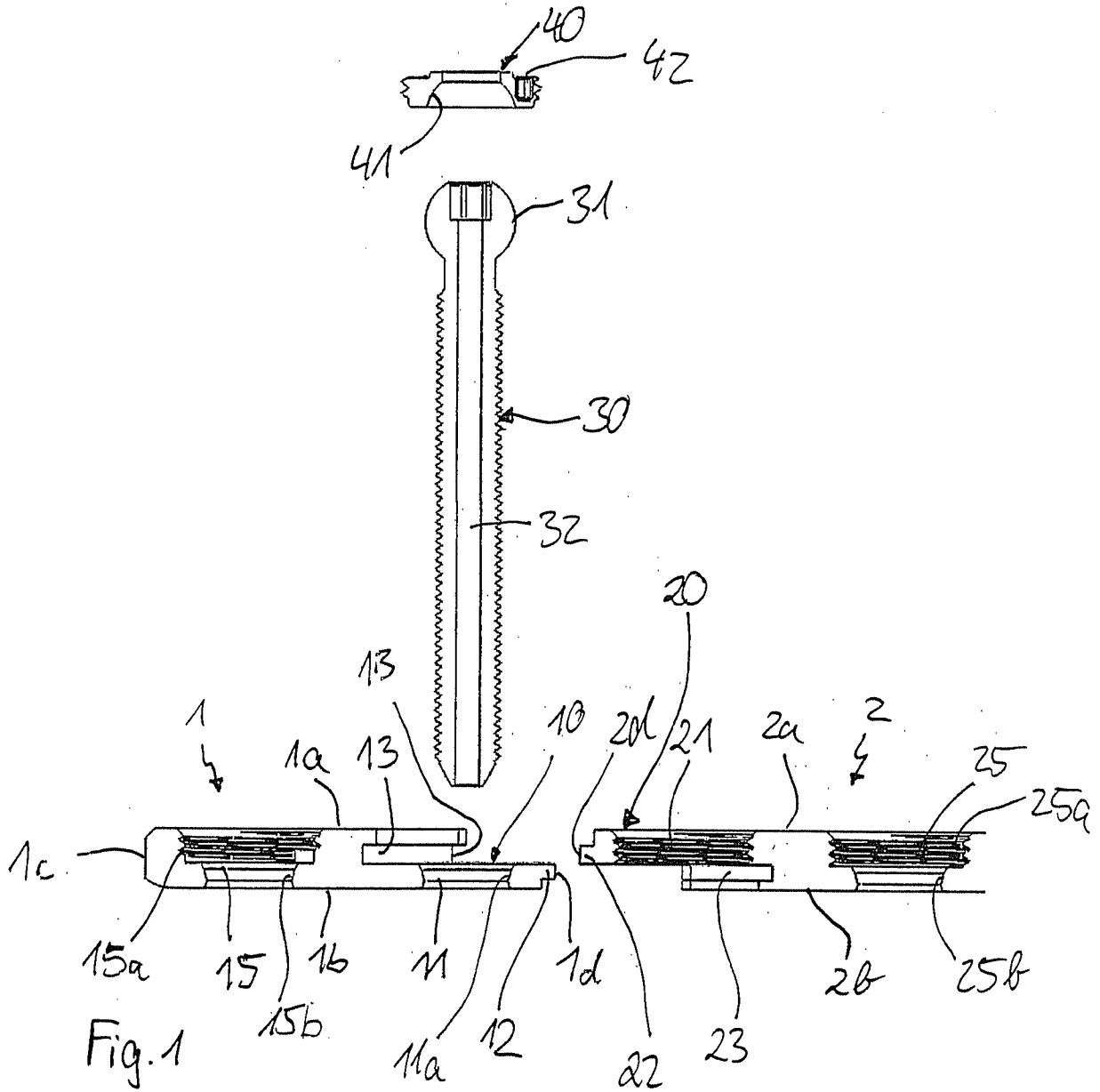

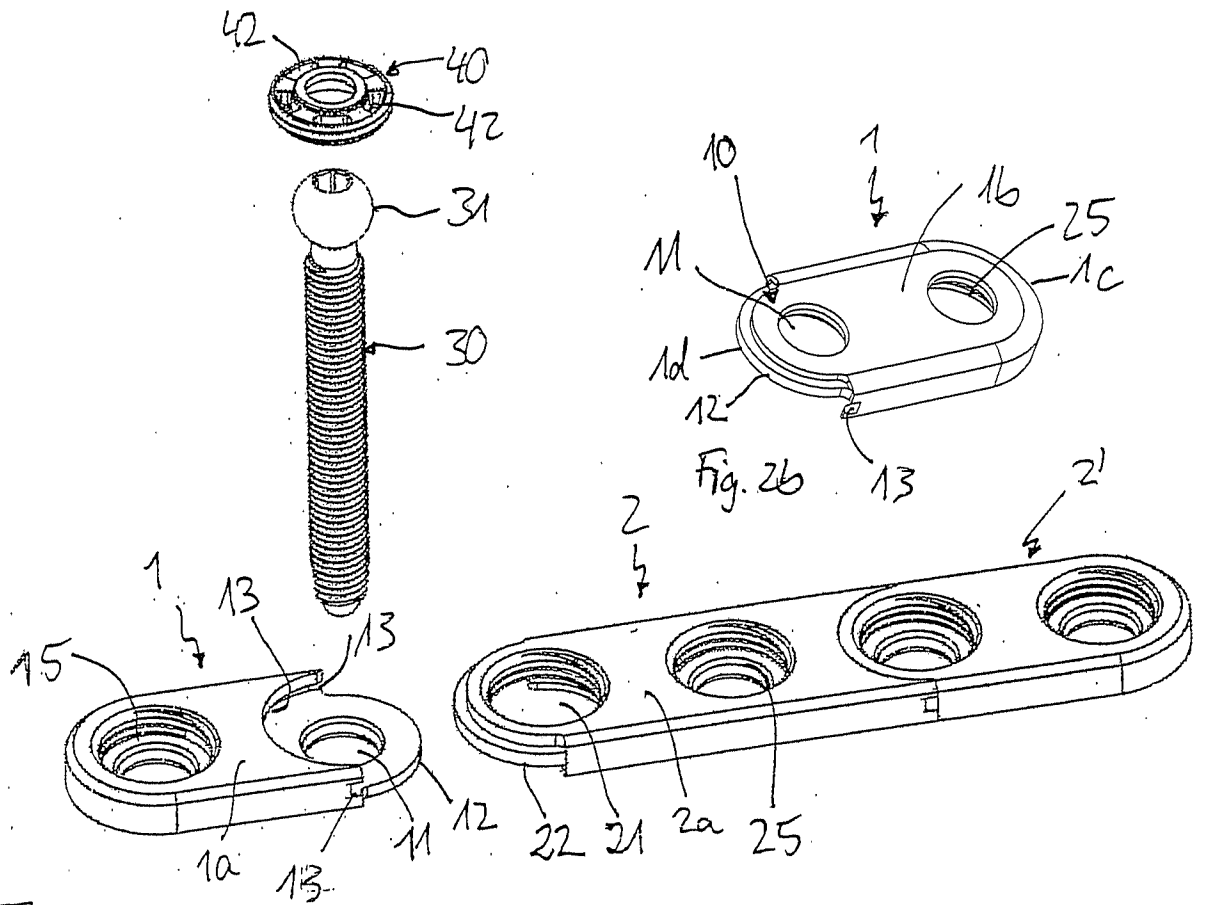

Fig. 2a

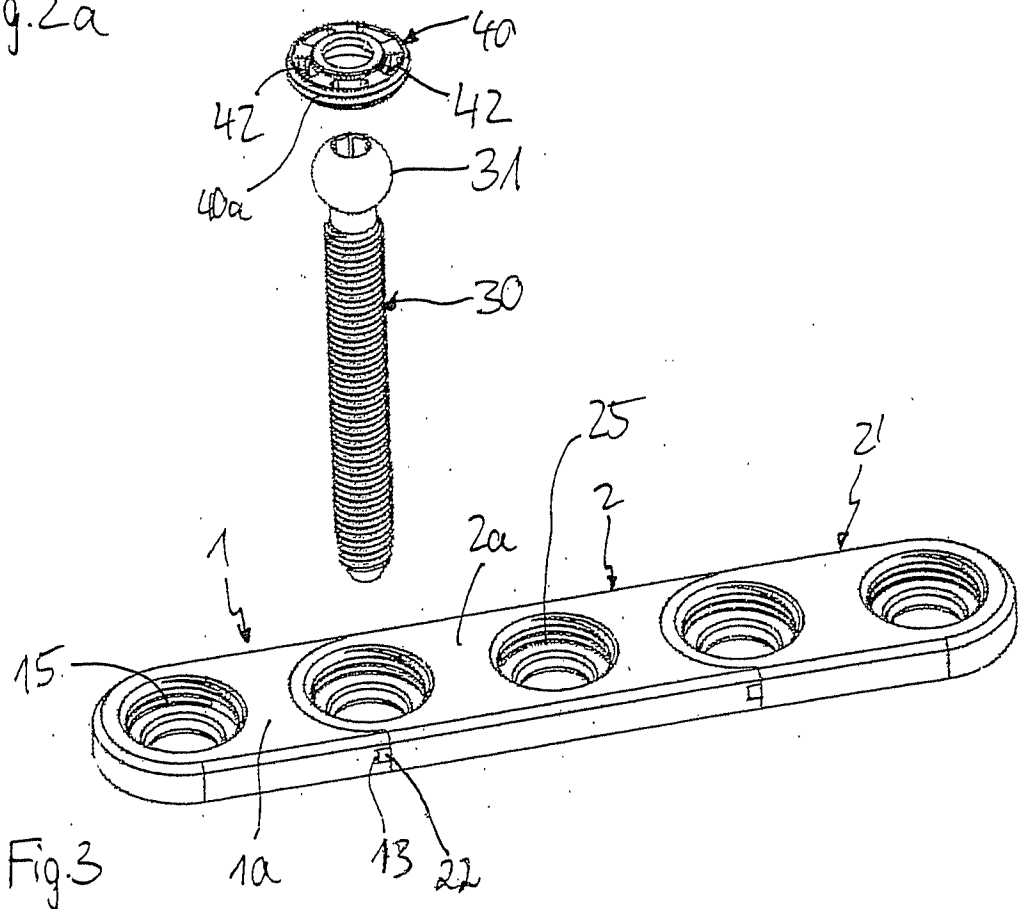

Fig. 3

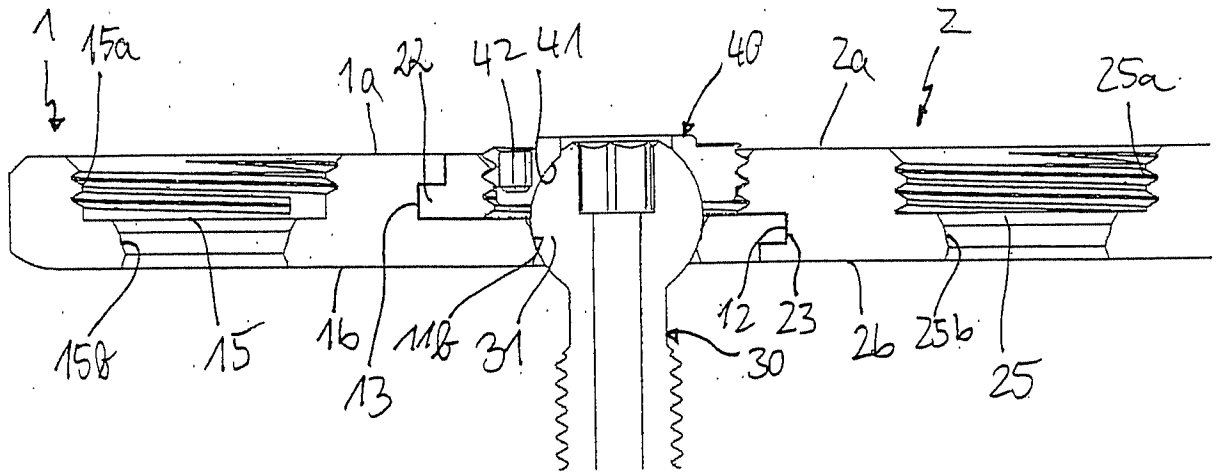

Fig. 4

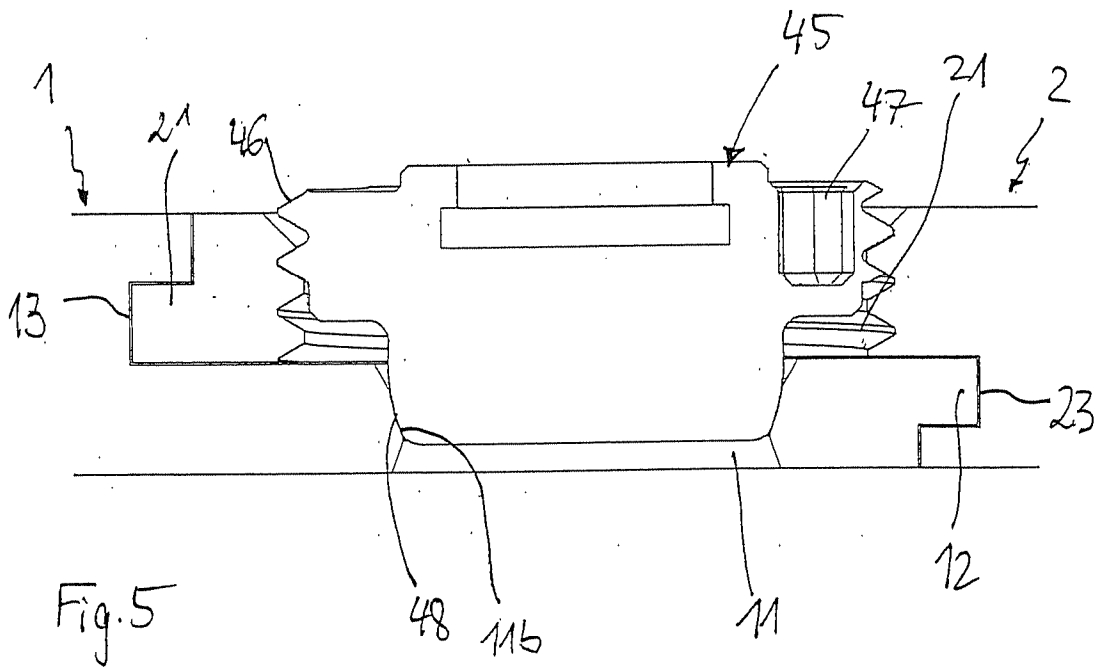

Fig. 5

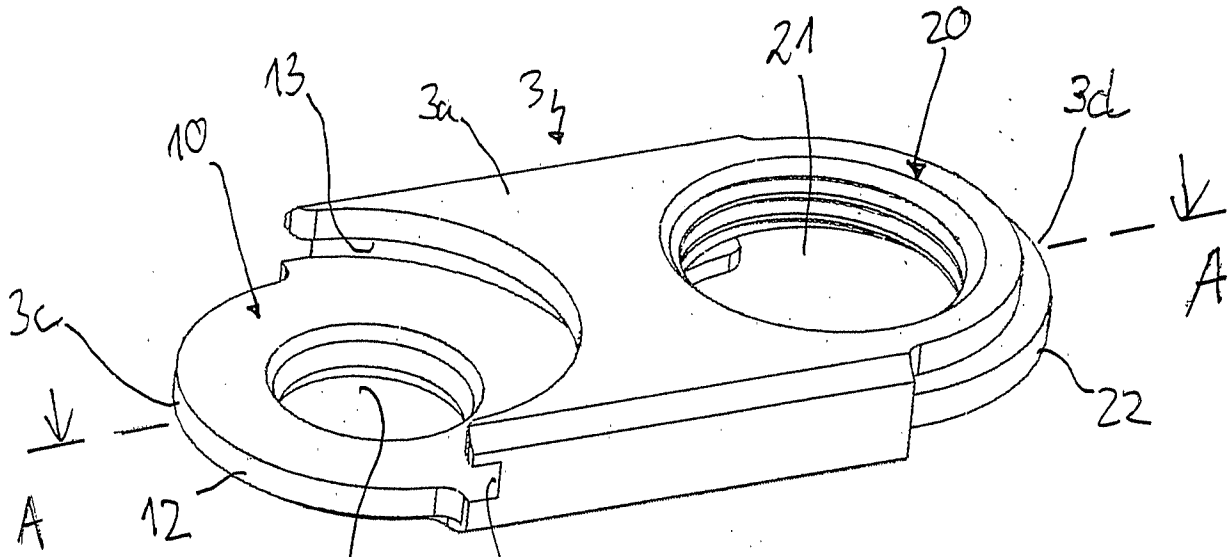

Fig. 6

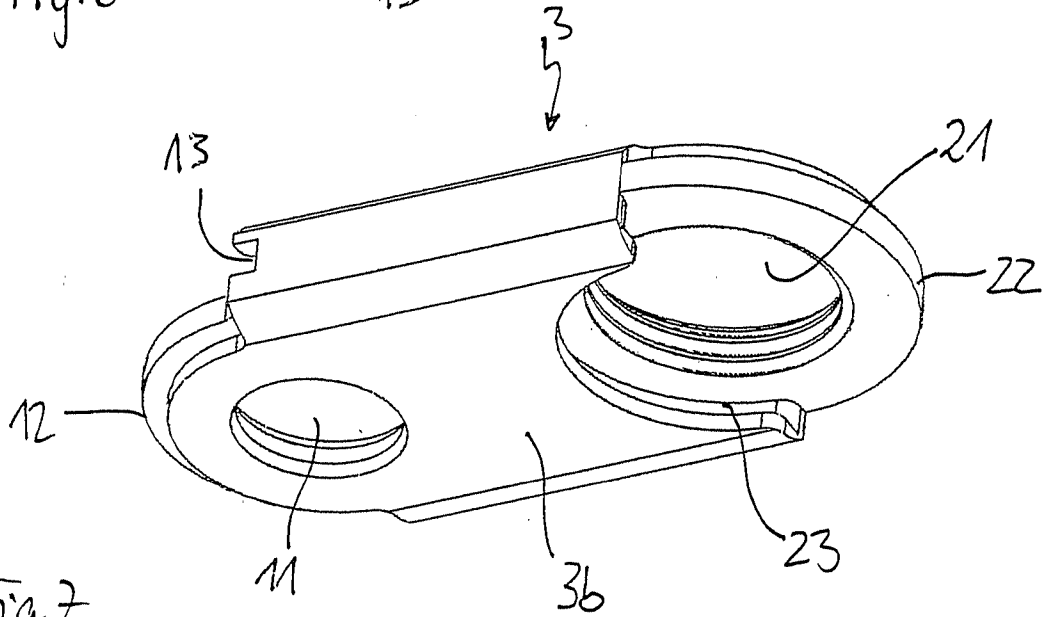

Fig. 7

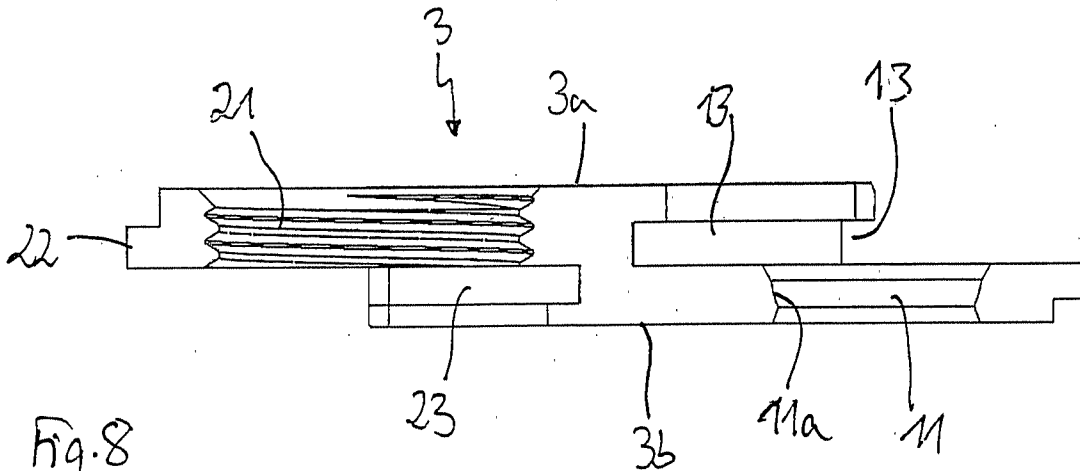

Fig. 8

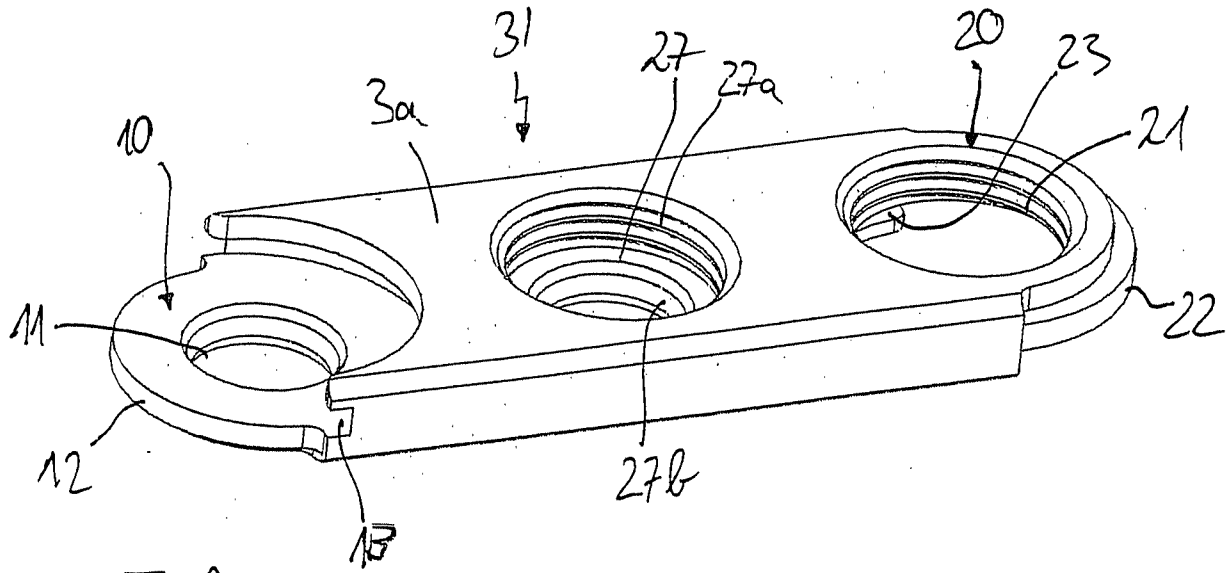

Fig. 9

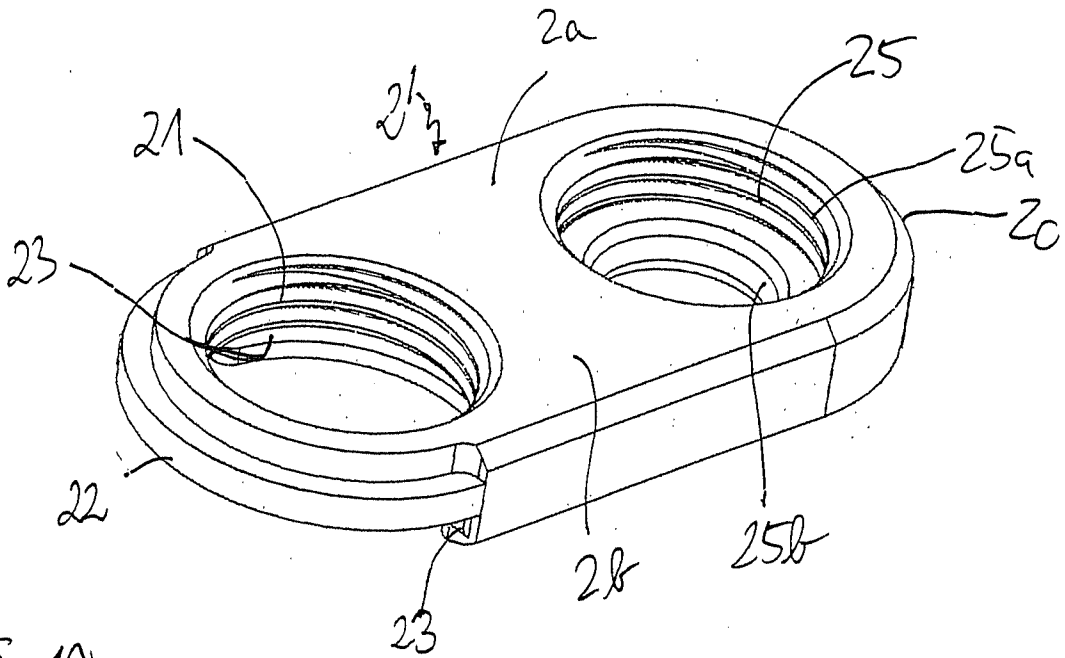
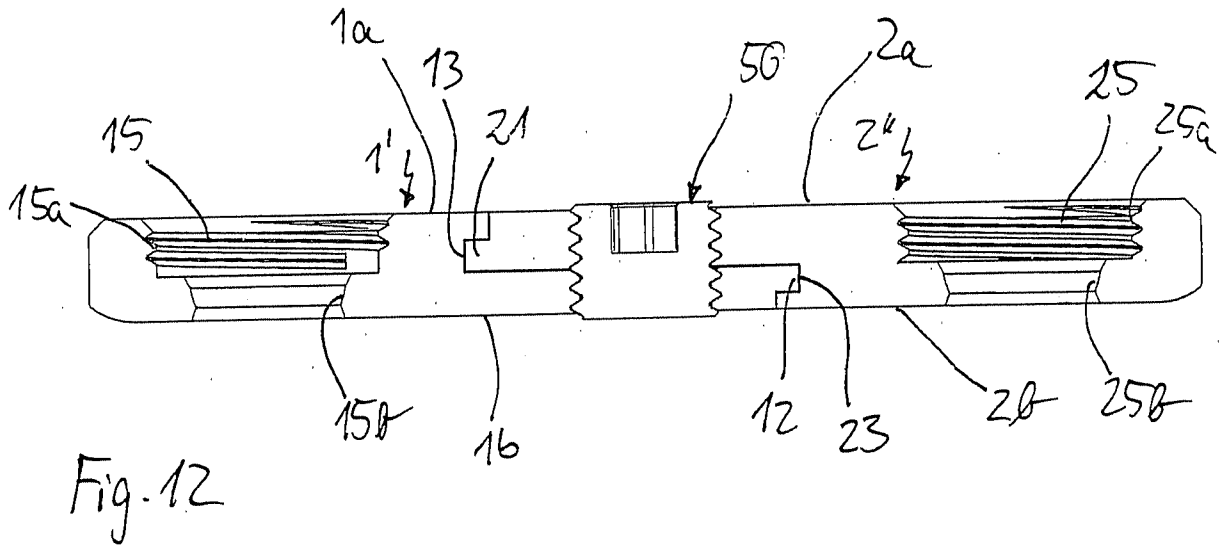
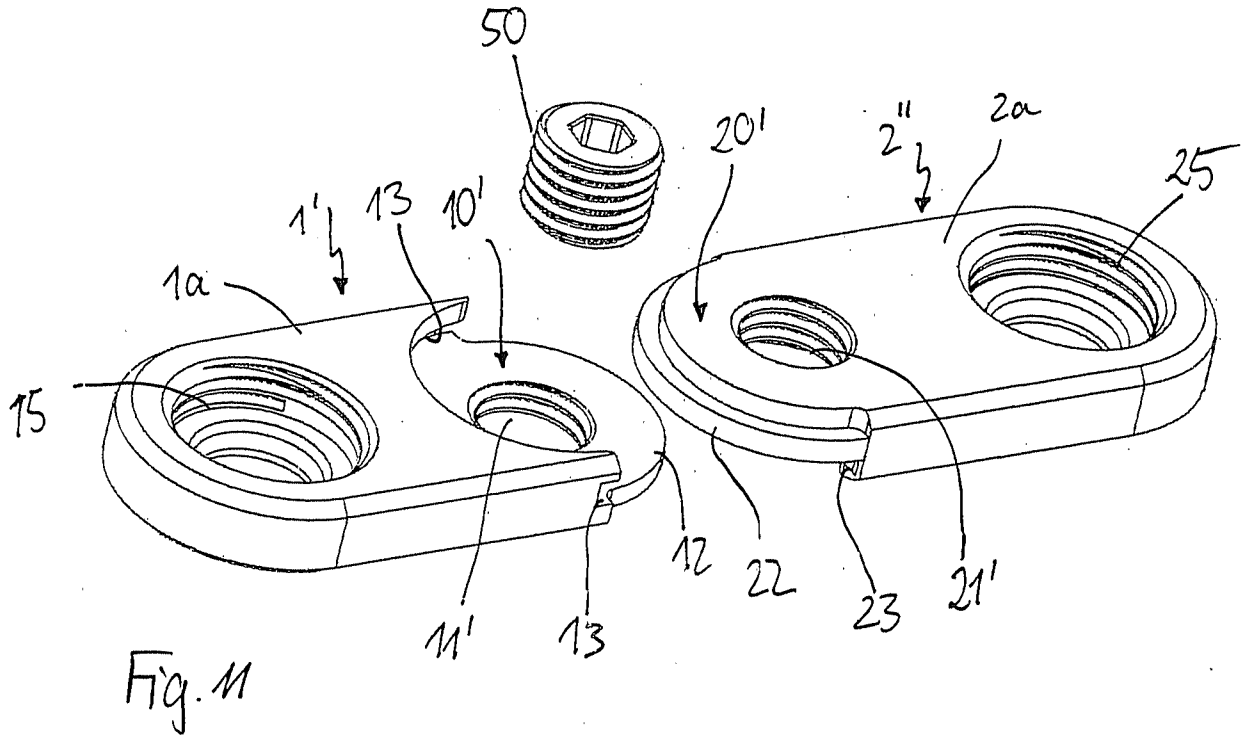

Fig. 10



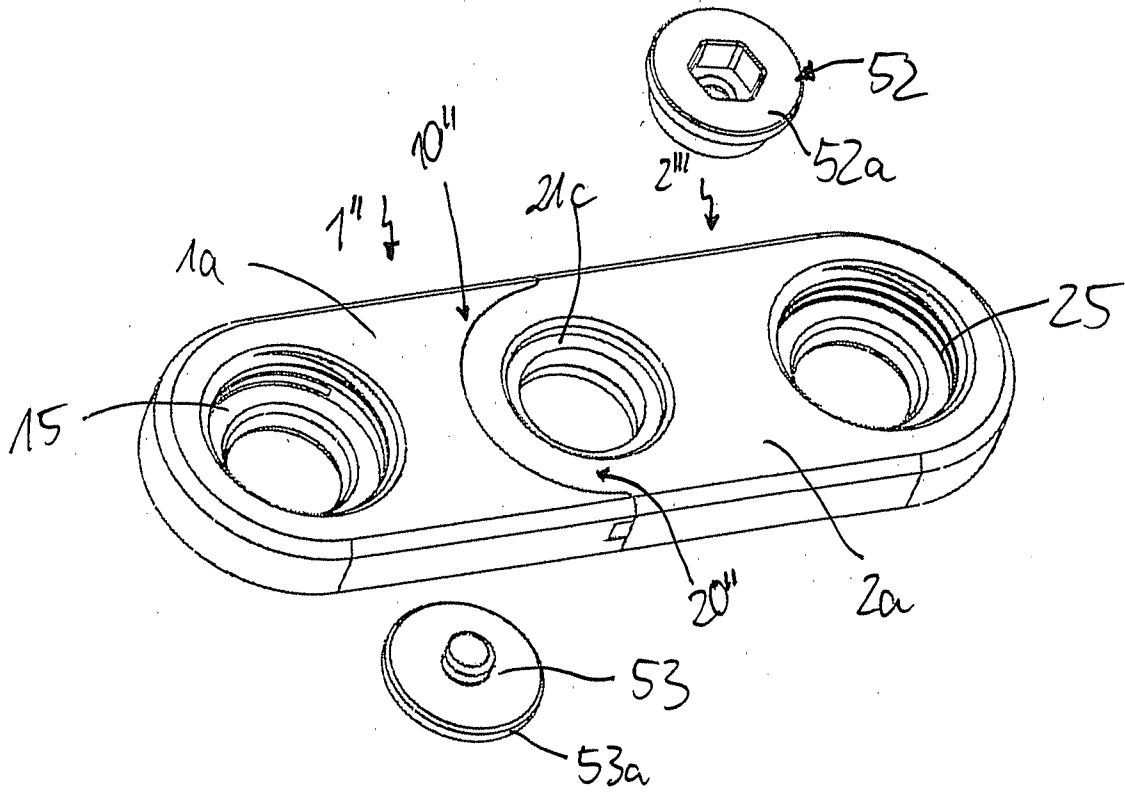

Fig. 13

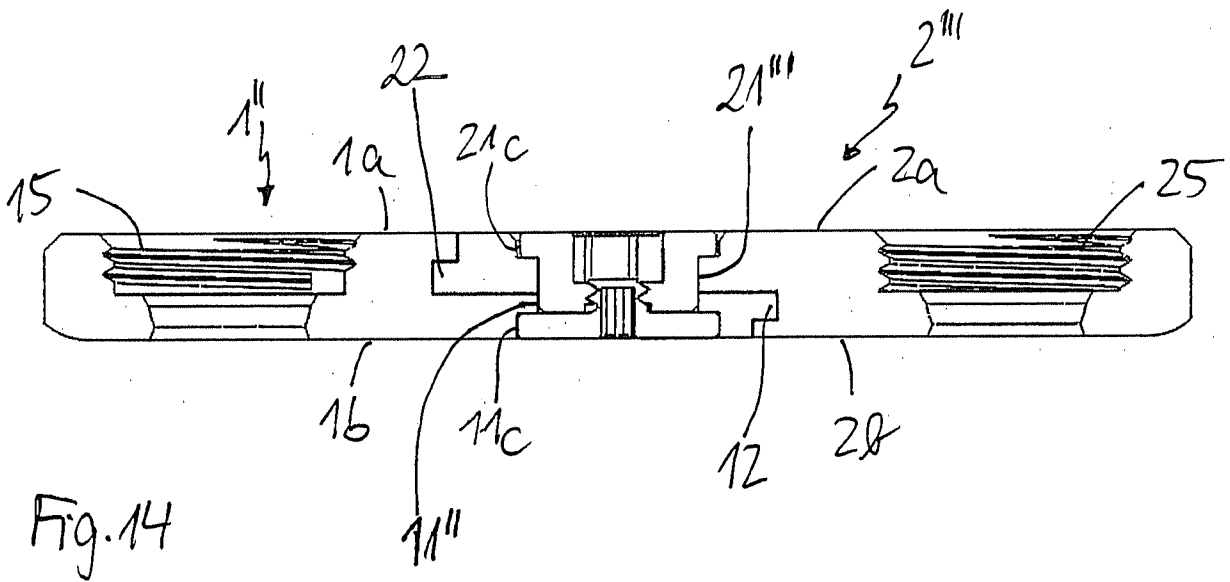

Fig. 14



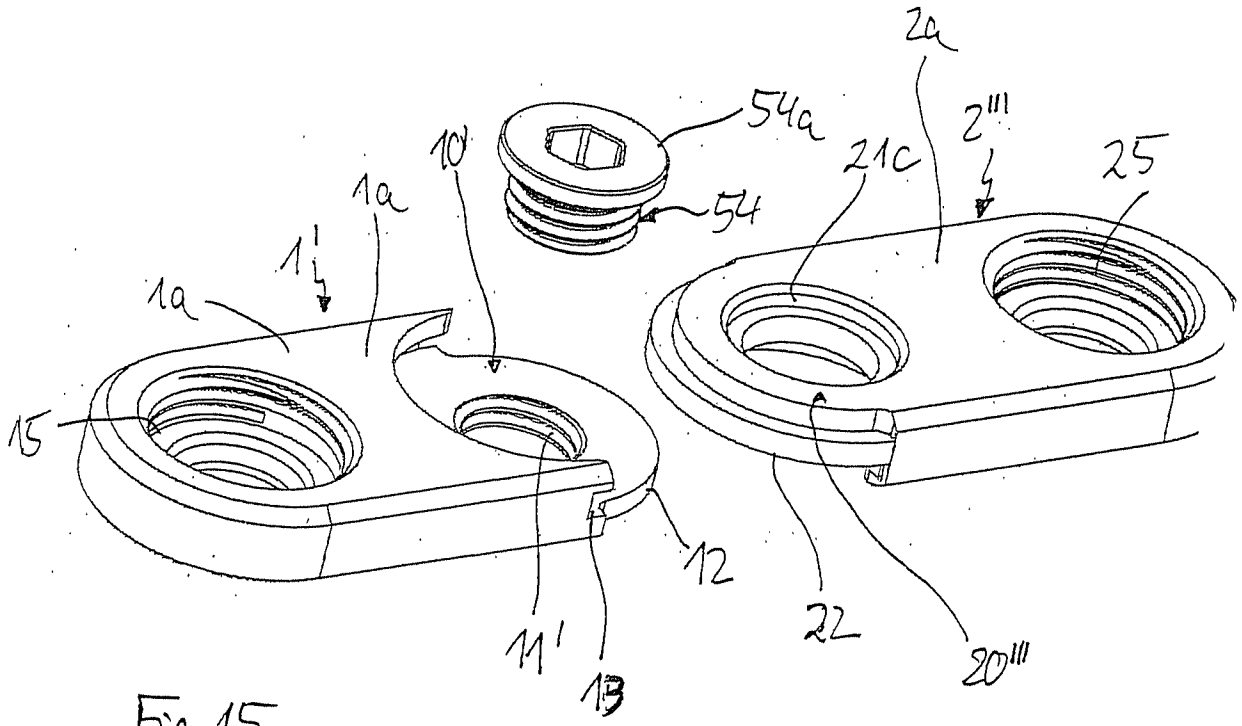

Fig. 15

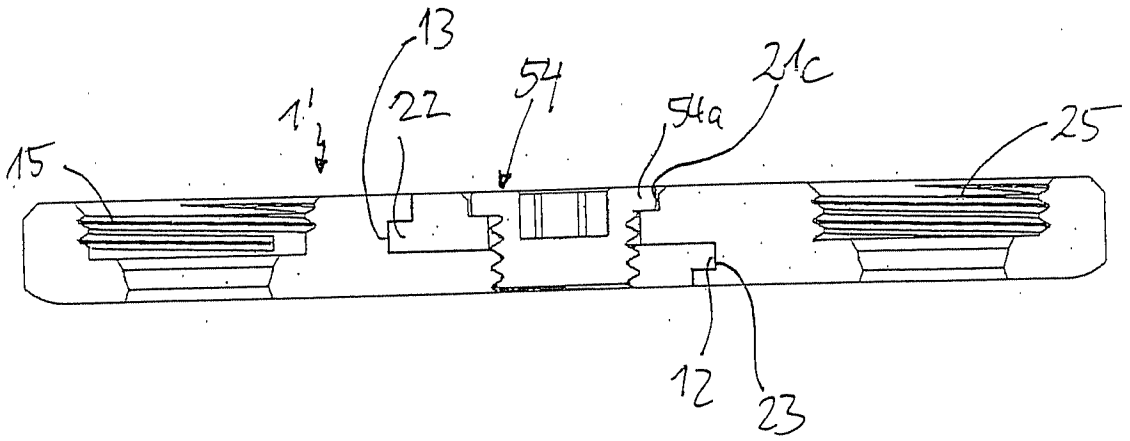
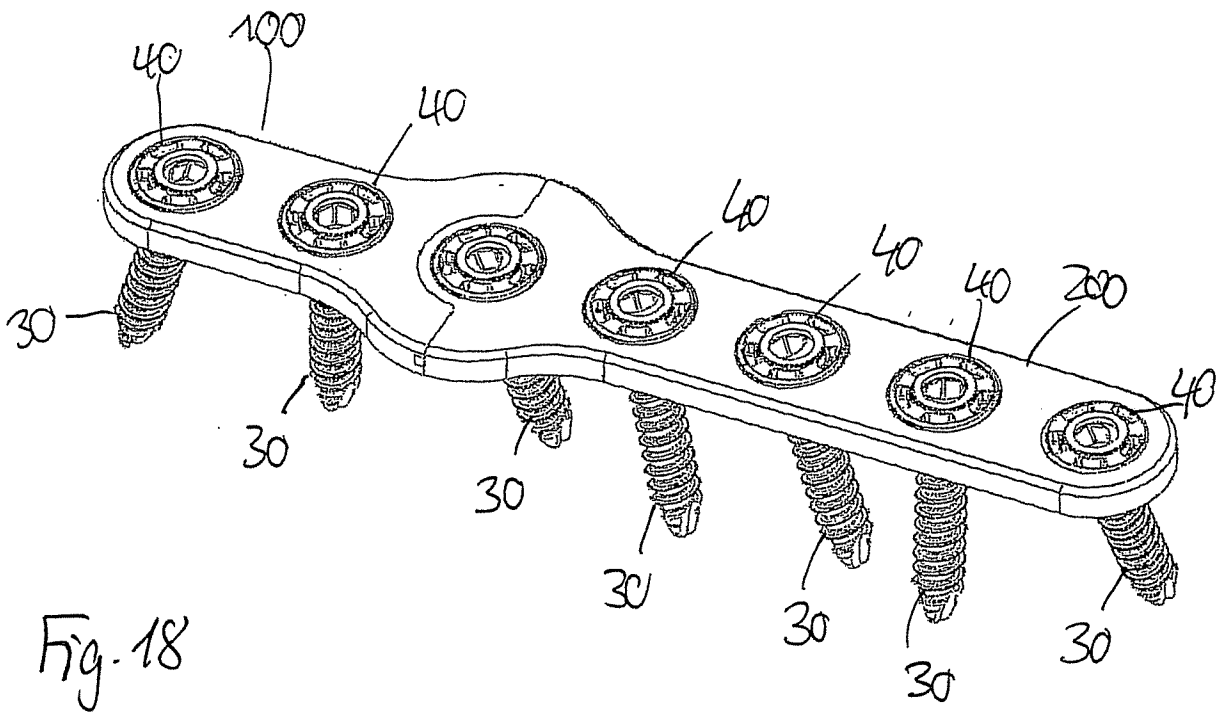
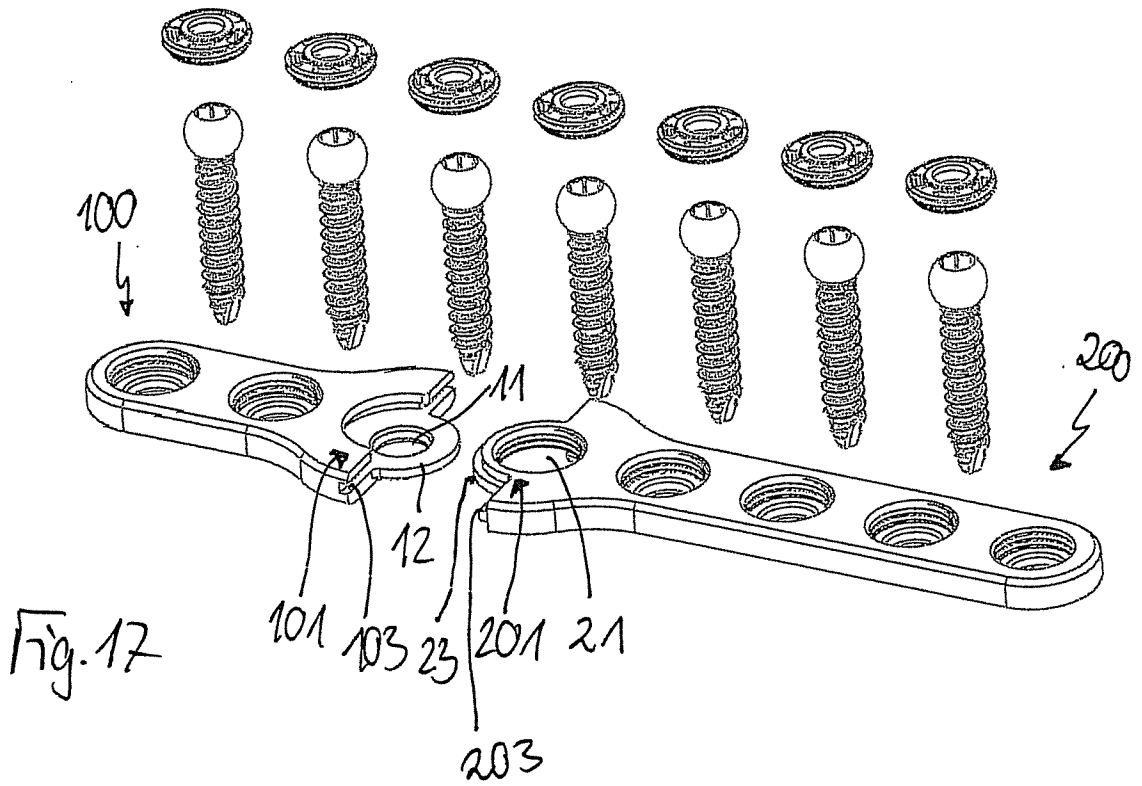

Fig. 16



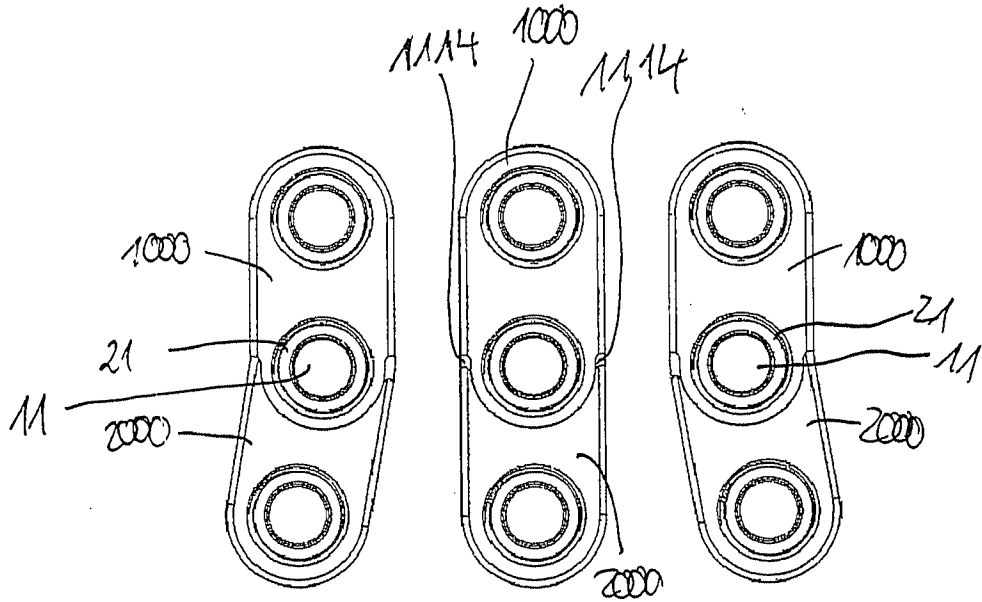

Fig. 19 a)

b)

c)

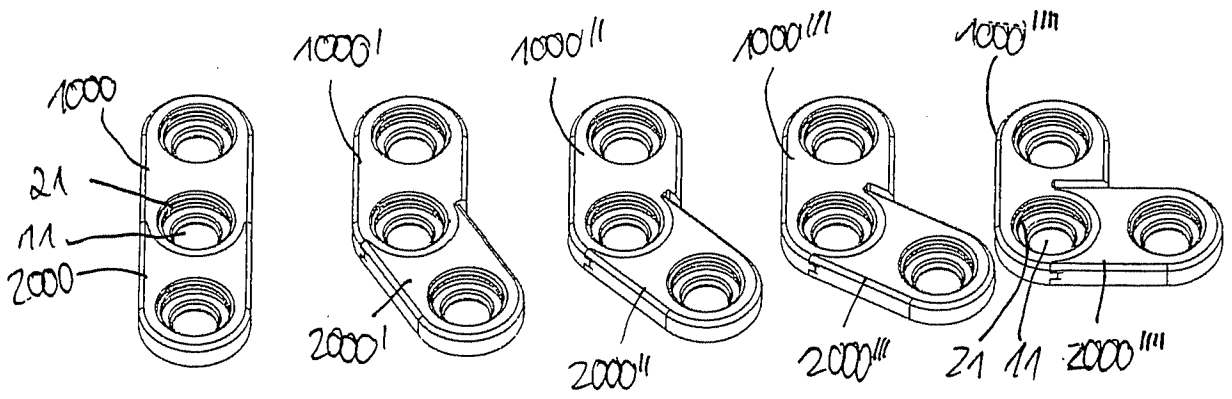

Fig. 20 a)

b)

c)

d)

e)

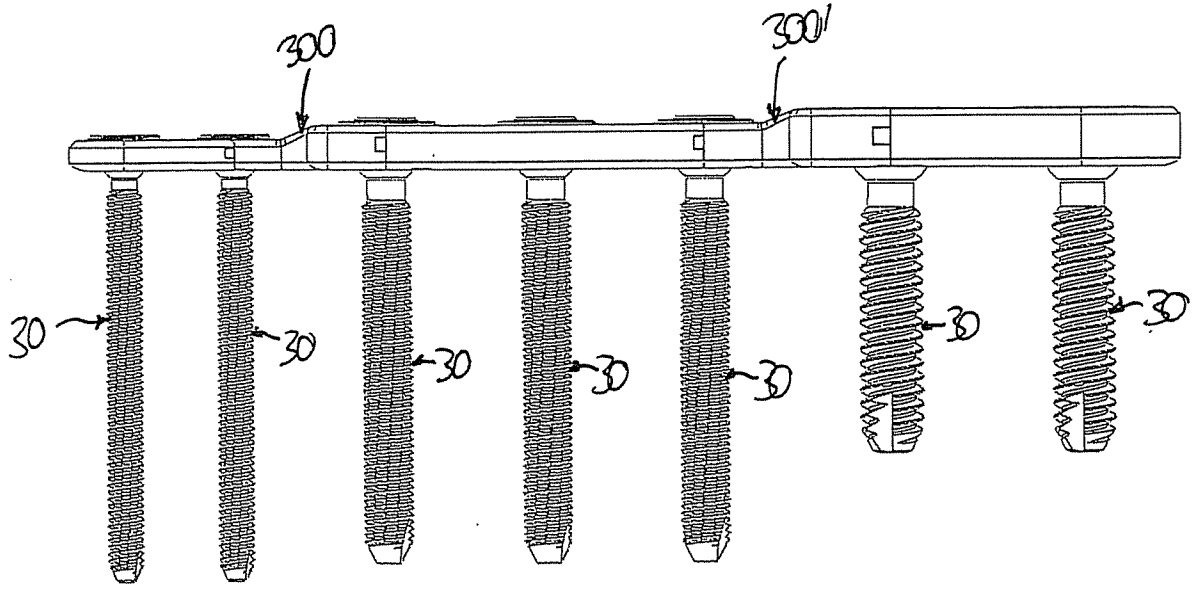

Fig. 21

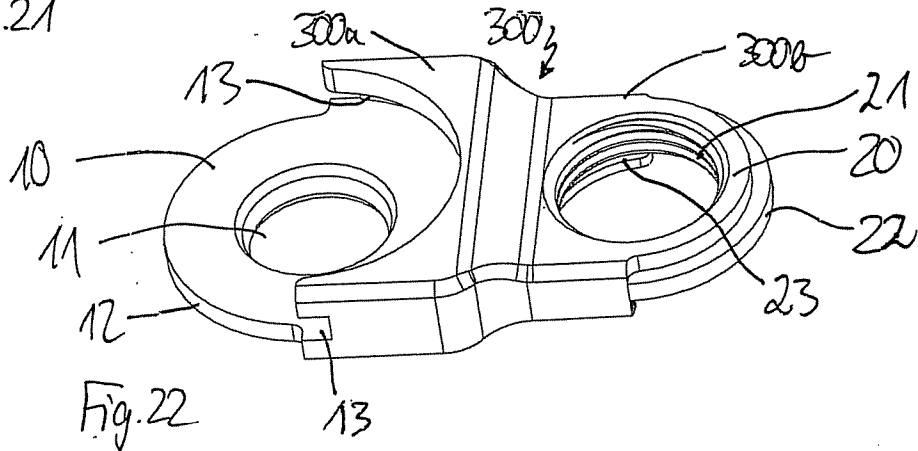

Fig. 22

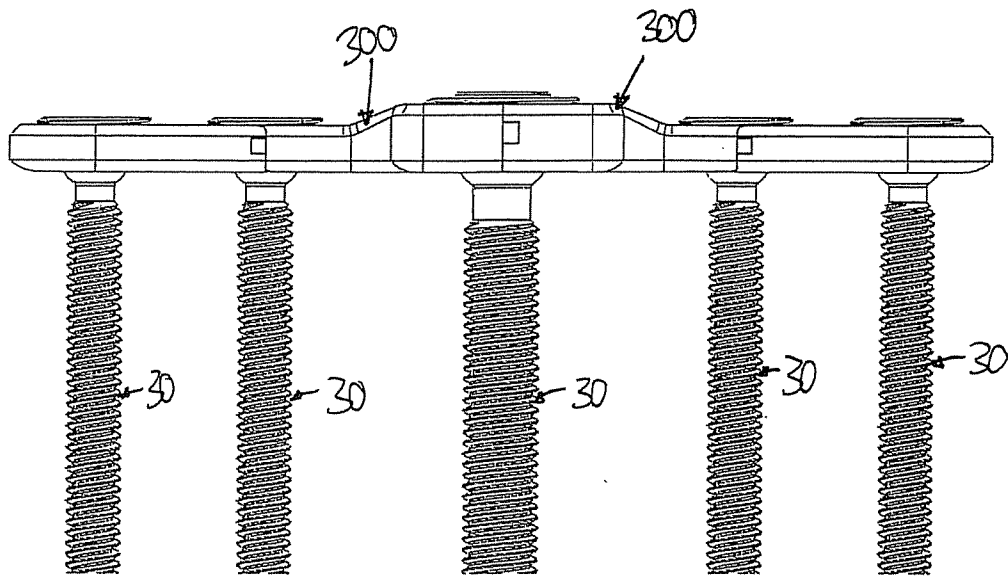
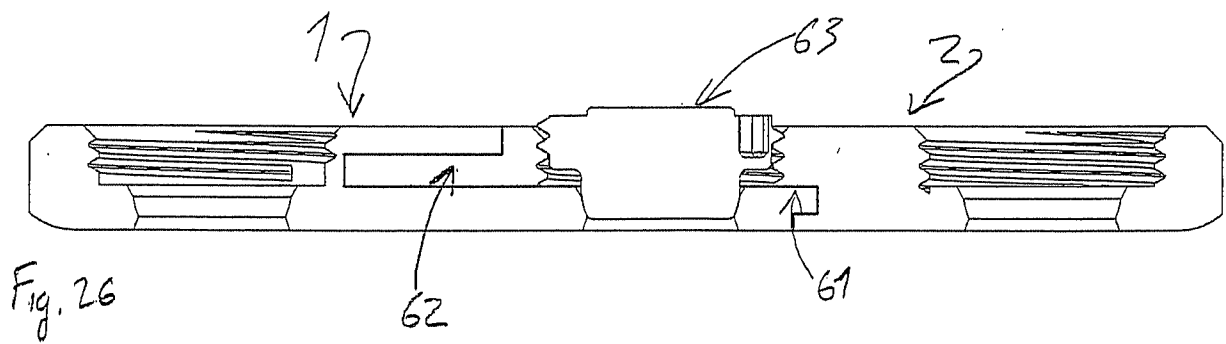
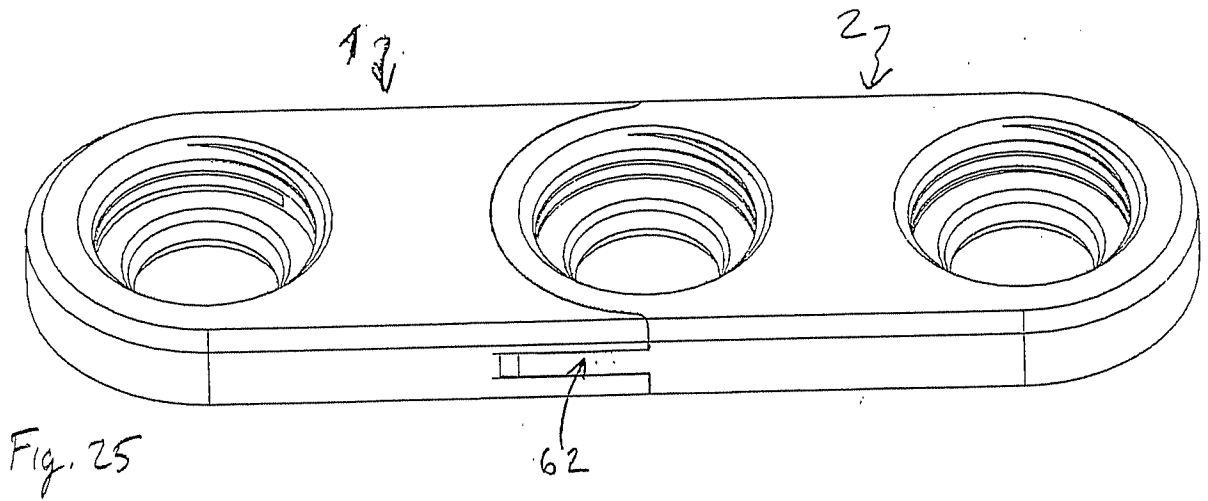
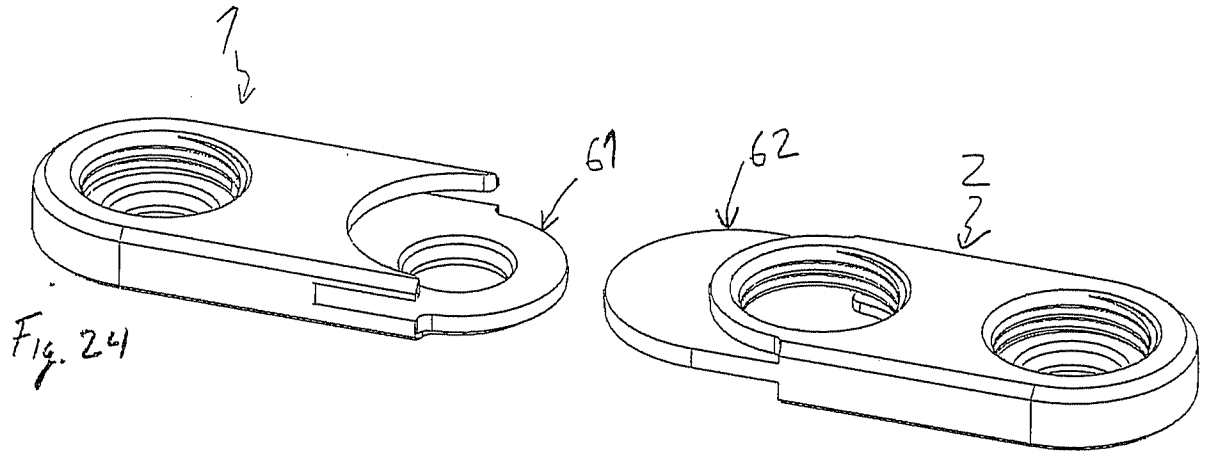

Fig. 23



## INTERNATIONAL SEARCH REPORT

International application No

PCT/IB2012/053037

## A. CLASSIFICATION OF SUBJECT MATTER

INV. A61B17/80  
ADD.

According to International Patent Classification (IPC) or to both national classification and IPC

## B. FIELDS SEARCHED

Minimum documentation searched (classification system followed by classification symbols)

A61B

Documentation searched other than minimum documentation to the extent that such documents are included in the fields searched

Electronic data base consulted during the international search (name of data base and, where practicable, search terms used)

EPO-Internal

## C. DOCUMENTS CONSIDERED TO BE RELEVANT

Category*	Citation of document, with indication, where appropriate, of the relevant passages	Relevant to claim No.
X	US 2009/082813 A1 (LONG JACK F [US] ET AL) 26 March 2009 (2009-03-26) cited in the application paragraph [0026] - paragraph [0029]; figures 1,2 paragraph [0031] - paragraph [0034]; figures 3,4 paragraph [0035] - paragraph [0037]; figures 5, 6, 7 paragraph [0038] - paragraph [0040]; figure 10	1-19
A	----- US 5 484 439 A (OLSON C DONALD [US] ET AL) 16 January 1996 (1996-01-16) cited in the application column 4, line 2 - column 5, line 12; figures 1-3 -----	1-19

 Further documents are listed in the continuation of Box C. See patent family annex.

## \* Special categories of cited documents :

"A" document defining the general state of the art which is not considered to be of particular relevance

"E" earlier application or patent but published on or after the international filing date

"L" document which may throw doubts on priority claim(s) or which is cited to establish the publication date of another citation or other special reason (as specified)

"O" document referring to an oral disclosure, use, exhibition or other means

"P" document published prior to the international filing date but later than the priority date claimed

"T" later document published after the international filing date or priority date and not in conflict with the application but cited to understand the principle or theory underlying the invention

"X" document of particular relevance; the claimed invention cannot be considered novel or cannot be considered to involve an inventive step when the document is taken alone

"Y" document of particular relevance; the claimed invention cannot be considered to involve an inventive step when the document is combined with one or more other such documents, such combination being obvious to a person skilled in the art

"&amp;" document member of the same patent family

Date of the actual completion of the international search

7 September 2012

Date of mailing of the international search report

13/09/2012

Name and mailing address of the ISA/

European Patent Office, P.B. 5818 Patentlaan 2  
NL - 2280 HV Rijswijk  
Tel. (+31-70) 340-2040,  
Fax: (+31-70) 340-3016

Authorized officer

Filali, Salima

# INTERNATIONAL SEARCH REPORT

Information on patent family members

International application No

PCT/IB2012/053037

Patent document cited in search report	Publication date	Patent family member(s)	Publication date
US 2009082813	A1	US 2009082813 A1	26-03-2009
		WO 2009042512 A1	02-04-2009
-----			
US 5484439	A	NONE	
-----			