

(12) **UK Patent Application** (19) **GB** (11) **2 210 733** (13) **A**

(43) Date of A publication 14.06.1989

(21) Application No 8823155.0

(22) Date of filing 03.10.1988

(30) Priority data
(31) 62250104 (32) 02.10.1987 (33) JP

(71) Applicant
Matsushita Electric Industrial Company Limited
1006 Oaza Kadoma, Kadoma-shi, Osaka, Japan

(72) Inventors
Genki Kondo
Kazushi Usui

(74) Agent and/or Address for Service
J A Kemp and Co
14 South Square, Gray's Inn, London, WC1R 5EU,
United Kingdom

(51) INT CL⁴
H02K 1/12 // H02K 1/02

(52) UK CL (Edition J)
H2A ACA ACG

(56) Documents cited
None

(58) Field of search
UK CL (Edition J) H2A ACA ACB ACD ACE ACF
ACG AHA AHB
INT CL⁴ H02K

(54) **Two-piece motor stator**

(57) A two-piece motor stator having: a generally annular inner iron stator core 2 having a plurality of teeth 5 extending radially outwardly from outer surface thereof, an annular outer iron stator core 1 having slots 4 in the inner surface thereof for receiving tip of the teeth, and coils 3 provided around the body of the teeth respectively before the inner and outer iron cores being combined by fit, wherein the outer iron stator core has at least one channel 6 made in the inner surface, each of the channels being formed along side of the slots for absorbing stress caused by fitting the tips into the slots in order to reduce the degree of deformation of the inner and outer stator iron cores. The channels may be made in the tip of the teeth instead of the inner surface of the outer iron stator. The channels also may be filled with a deformable and magnetically soft material e.g. silicon steel powder in a rubber foam

FIG. 3

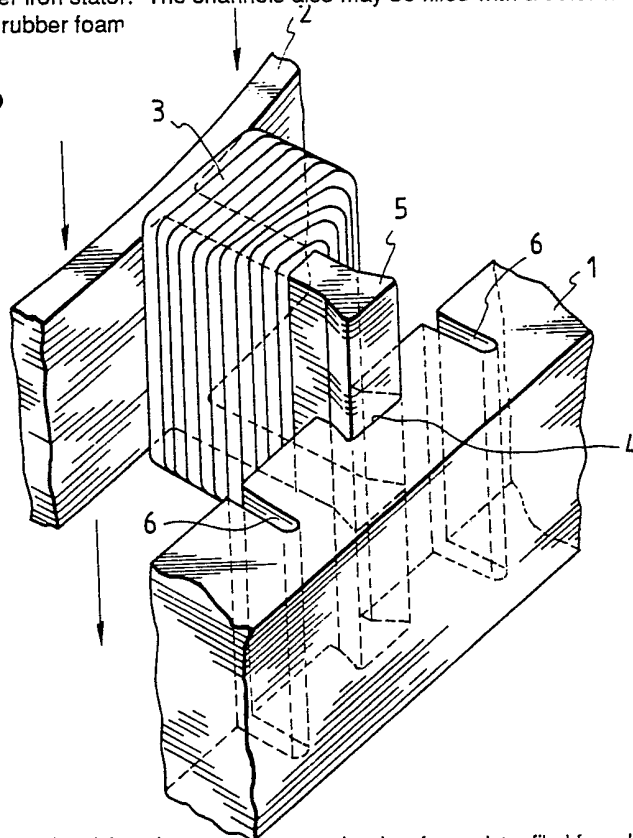

At least one drawing originally filed was informal and the print reproduced here is taken from a later filed formal copy.

GB 2 210 733 A

FIG. 1

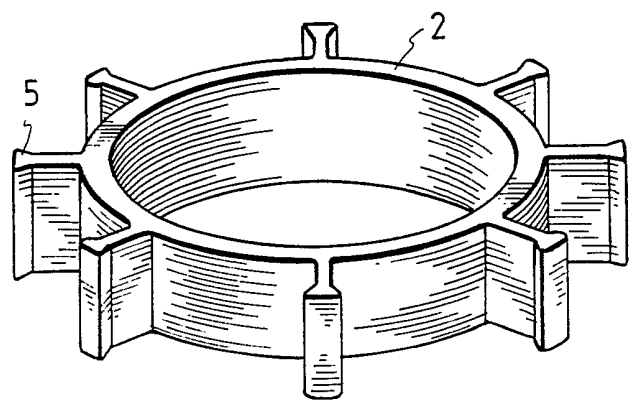

FIG. 2

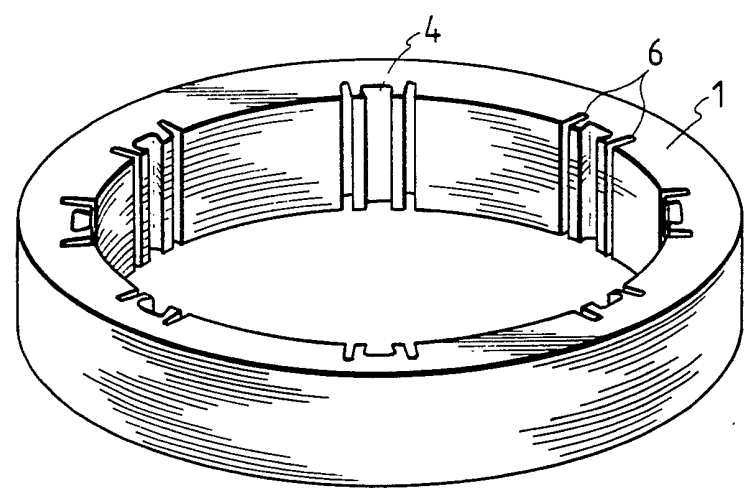

FIG. 3

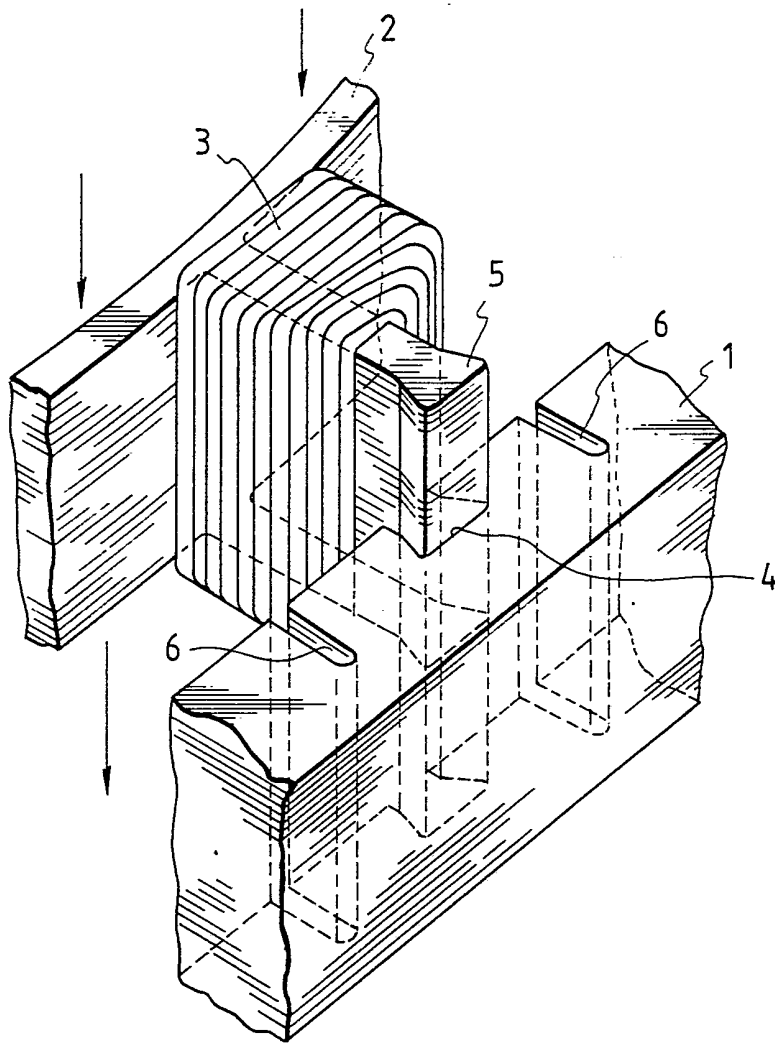

FIG. 4

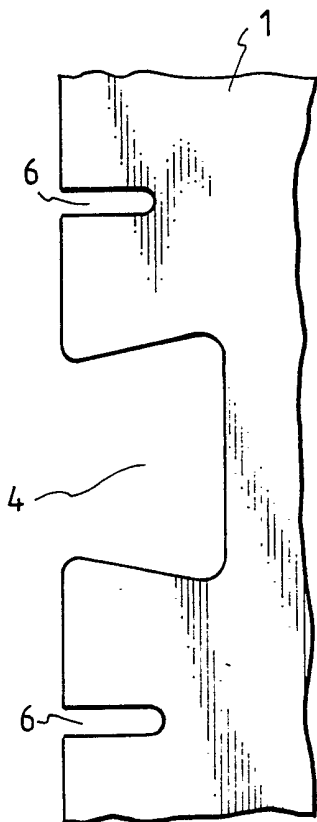

FIG. 5

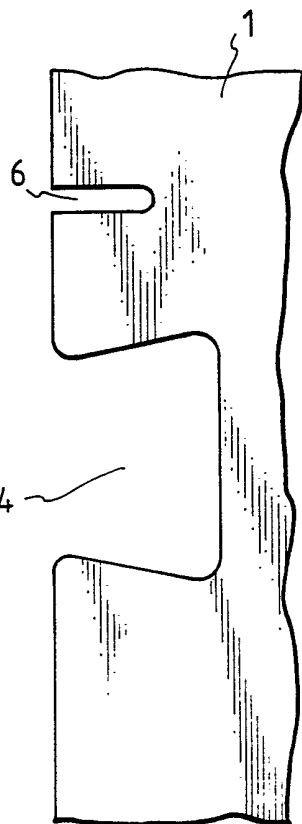

FIG. 7

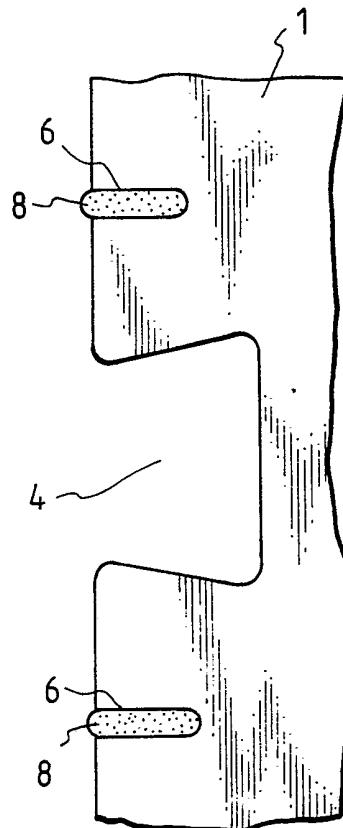

FIG. 6

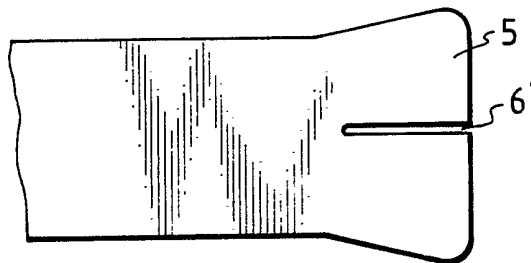

FIG. 8

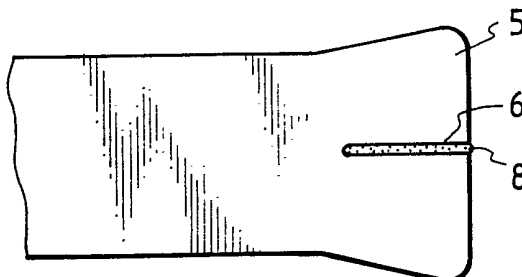
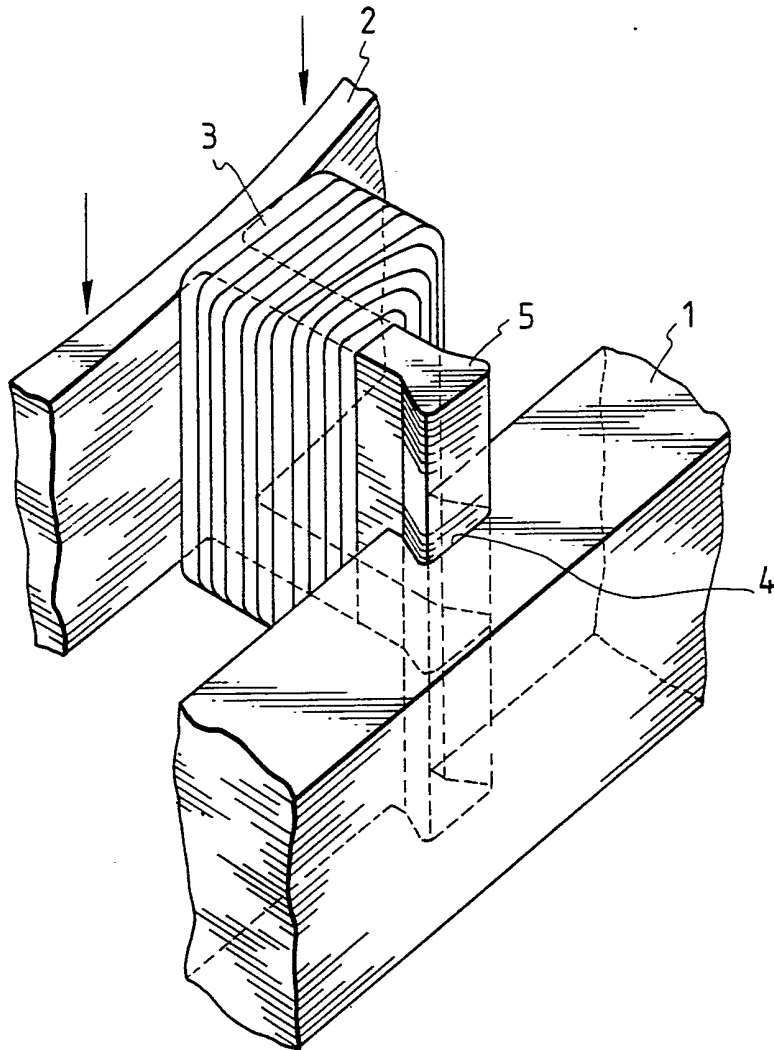

FIG. 9
PRIOR ART



- 1 -

TWO-PIECE MOTOR STATOR

This invention relates to a two-piece motor stator having outer and inner iron stator cores which form one body by fitting together.

Various types of two-piece motor stators are known, to be fixedly mounted in a motor housing which also houses a rotor. The use of a two-piece motor stator, i.e., dividing a stator core into outer and inner cores, is to make the motor smaller and lower the manufacturing cost. Such stator comprises an inner stator core having a plurality of teeth and an outer stator core having a plurality of slots for engaging the teeth with the tip of each tooth fitted into a slot. At first, a wire is wound on each tooth to form a coil. Then, the inner core is engaged with the outer core by press fit. This structure makes the winding process easier, thereby lowering manufacturing cost. The cores are magnetic, e.g. ferrous or iron.

Fig. 9 shows such two-piece motor stator when combined in a fragmentary perspective view. An annular outer iron core 1 is made of laminated magnetic plates. Inside the outer core 1, a generally annular iron core 2 is provided with the central axis thereof coincident with that of the outer core 1. The outer and inner stator cores 1, 2 are combined by press fit, as shown in Fig. 9. The resultant stator core is assembled in an unshown motor housing together with an unshown rotor with the central axis

of the outer and inner stator cores 1, 2 coincident with the rotation axis of the rotor. The inner core 2 has a plurality of teeth 5 extending radially outwardly from the outer surface thereof. A coil 3 is a wire wound around a tooth 5 of the inner core 2. A slot 4 is made in the inner surface of the outer stator core 1. The tooth 5 is provided for engaging with the slot 4. The slot 4 is formed to be complementary to the tip of the tooth 5 in cross-sectional shape. Therefore, the outer core 1 can be engaged with the inner stator core 2 with the tip of the tooth 5 fitted into the slot 4.

However, in such two-piece motor stator, the above-mentioned structure causes deformation at the inner peripheral portion of the inner core 2 and the outer peripheral portion of the outer core 1. The deformation of the former portion causes an increase in motor-running noises level, while the deformation of the latter portion results in difficult assembling.

The reasons of the deformation are as follows:

The outer and inner stator cores 1, 2 are engaged with the slot 4 fitted with the tooth 5 by transition of interference fit. Therefore, a considerably large power is required for fitting. Fit requiring large power causes stress in the outer and inner cores 1, 2, thereby generating such deformation.

Therefore, in the prior art two-piece motor stator, there is a drawback that undesirable deformation of the stator core deteriorates the performance of the motor.

The present invention has been developed in order to reduce the above-described drawbacks.

According to the present invention there is provided a two-piece stator having;

a generally annular inner stator core having a plurality of teeth extending radially outwardly from the outer surface thereof, an annular outer stator core having slots in the inner surface thereof for receiving the tips of said teeth, and coils provided around the bodies of said teeth respectively, before said inner and outer iron cores are combined by fit, and including channels formed in said inner surface adjacent said slots.

The invention also provides a two-piece stator having;

a generally annular inner stator core having a plurality of teeth extending radially outwardly from the outer surface thereof, an annular outer stator core having slots in the inner surface thereof for receiving the tips of said teeth, and coils provided around the bodies of said teeth respectively, before said inner and outer iron cores are combined by fit, and including channels formed in the tips of said teeth and extending substantially radially.

The invention thus provides a two-piece motor stator which is capable of reducing the degree of deformation at the inner and outer iron stator cores which is caused on the fitting.

According to one aspect of the present invention, a plurality of channels are so made in the inner surface of the annular outer stator core that a channel is formed by each of the slots for absorbing stress due to fitting the tips of the teeth into the slots.

In another aspect there is provided a plurality of channels formed in the tips of the teeth for absorbing stress due to fitting the tips of the teeth into the slots.

Preferably there is provided a deformable and magnetically soft material with which the channels are filled.

An advantage of the present invention is that the channels reduce the power needed for press fit. Another advantage of the present invention is that the channels reduce noise problems due to deformation of the stator core and assembling problems of motor, thereby providing higher productivity and higher quality of motor.

The present invention will become more readily apparent from the following detailed description of the preferred embodiments taken in conjunction with the accompanying drawings in which:

Fig. 1 is a perspective view of the inner iron stator core of the first embodiment;

Fig. 2 is a perspective view of the outer iron stator core of the first embodiment;

Fig. 3 is a fragmentary perspective view of the inner and outer iron stator cores of the first embodiment, which are under fitting;

Fig. 4 is a fragmentary plan view of the outer iron stator core of the first embodiment;

Fig. 5 is a fragmentary plan view of the outer iron stator core of the second embodiment;

Fig. 6 is a fragmentary plan view of the inner iron stator core of the third embodiment;

Fig. 7 is a fragmentary plan view of the outer iron stator core of the fourth embodiment;

Fig. 8 is a fragmentary plan view of the inner iron stator core of the fifth embodiment;

Fig. 9 is a fragmentary perspective view of the inner and outer iron stator cores of conventional two-piece motor stator, which are under fitting.

The same or corresponding elements and parts are designated by like reference numerals throughout the drawings.

Referring to Figs. 1, 2 and 3, schematic diagrams of a first embodiment of the present invention are shown by way of a perspective view.

A generally annular inner iron stator core 2 of Fig. 1 is made of laminated iron plates. The inner iron

stator core 2 has eight teeth 5 which are arranged in the axial planes of the ring shape thereof, like a spur gear. Fig. 2 shows an annular outer iron stator core 1 made of laminated iron plates, which has eight slots 4 on the inner surface thereof. The position of each slot 4 is corresponding to that of a tooth 5. The slot 4 is made to be complementary to the tip of the tooth 5 in cross-sectional shape. Therefore, the outer and inner iron stator cores 1, 2 can be combined into one body with each tip of the tooth 5 fitted into each slot 4, as shown in Fig. 3. Fig. 3 shows a tooth 5 being fitted into a slot 4. In Fig. 3, a coil is formed by winding a wire directly around the body of each tooth 5 before the outer and inner iron stator cores 1, 2 are combined. The outer iron stator core 1 has two channels 6 which are made near and parallel to each slot 4. Fig. 4 shows the slot 4 and the channels 6 in enlarged plan view of the outer iron stator core 1. The channels 6 are formed on both sides of slot 4 when viewed from the center of the ring shape of the outer iron stator core 1. The major dimensions are as follows:

depth of the channel 6 is about 1.5 mm;

width of the channel 6 is about 1 mm;

distance from the slot 4 to the channel 6 is about 2 mm.

depth of the slot 4 is about 3 mm;

width of the tip of the slot 4 is about 4 mm;

inside diameter of the inner iron core 2 is about 50 mm; and

outside diameter of the outer iron core 1 is about 94 mm.

However, these dimensions of the channel 6 are selected depending on hardness of the outer and inner iron stator cores 1, 2 and tolerance quality of the slot 4 and the tip of teeth 5. In Fig. 3, the channel 6 is provided in parallel with the slot 4. However, the channel 6 may be formed not in parallel with, but along the slot 4.

Hereinbelow will be described the operation of the channel 6. The dimensions of the tip of the teeth 5 and the slots 4 in the cross-sectional plane are so designed as to be fitted with an interference or transition fit in order to obtain enough combining strength of the inner iron stator core 2 with the outer iron stator core 1. Accordingly, when the inner iron stator 2 is combined with the outer iron stator core 1, stress is generated near the engaging portion. The stress causes deformation of the outer and inner iron stator cores 1, 2. The deformation at the inner surface of the inner iron stator core 2 causes running noise of the motor and unevenness of torque over one revolution of the unshown rotor. The deformation at the outside surface of the outer iron stator core 1 causes a problem of assembling. The channel 6 absorbs the stress which causes such deformation.

Fig. 5 is a fragmentary plan view of the outer iron core 1 of the second embodiment of the present invention, in which the channels 6 are formed near the slot 4 only on one side of each of slots 4 when viewed from the center of the outer iron core 1. This embodiment has an advantage of lower magnetic reluctance of the magnetic circuit which is formed by the inner iron stator core 2, teeth 5, and the outer iron stator core 1, compared with the stator core of the first embodiment.

Fig. 6 is a fragmentary plan view of the inner iron core 2 of a third embodiment of the present invention, in which a plurality of channels 6' are respectively formed in the tips of the teeth 5 and each of the channels extends substantially radially with respect to the center of axis of the inner iron stator core 2. This embodiment has an advantage of lower magnetic reluctance of the magnetic circuit which is formed by the inner iron stator core 2, teeth 5, and the outer iron stator core 1, compared with the stator core of the first embodiment of the present invention, in which the channel 6 is filled with a deformable and magnetically soft material 8. This embodiment has an advantage of lower magnetic reluctance of the magnetic circuit because the magnetically soft material passes magnetic flux. In addition, the width of the channel 6' can be made small because the position of the channel is very close to the fitting portion. Thus, the magnetic

reluctance is also reduced, compared with that of the stator core of the first embodiment.

Fig. 7 is a fragmentary plan view of the outer iron core 1 a fourth embodiment of the present invention, in which the channel 6 is filled with a deformable and magnetically soft material 8. This embodiment has an advantage of lower magnetic reluctance of the magnetic circuit because the magnetically soft material passes magnetic flux.

Fig. 8 is a fragmentary plan view of the inner iron core 2 of a fifth embodiment of the present invention, in which the channel 6 is also filled with a deformable and magnetically soft material 8. This embodiment has the advantage of lower magnetic reluctance of the magnetic circuit.

The deformable and magnetically soft material 8 of the fourth and fifth embodiments can be made in such a way that rubber foam containing silicon steel powder is injected into the channels 6 or 6'. Then, the deformable and magnetically soft material 8 injected is hardened.

According to the present invention, the channel 6 or 6' absorbs the stress due to fit so as to reduce the deformation of the outer and inner iron stator cores 1, 2, thereby eliminating the above-mentioned running noise and assembling problems.

The above-described embodiments are just examples of the present invention, and therefore, it will be apparent for those skilled in the art that many modifications and variations may be made without departing from the scope of the present invention.

CLAIMS

1. A two-piece stator having a generally annular inner stator core having a plurality of teeth extending radially outwardly from the outer surface thereof, an annular outer stator core having slots in the inner surface thereof for receiving the tips of said teeth, and coils provided around the bodies of said teeth respectively, before said inner and outer iron cores are combined by fit, and including channels formed in one or both of the cores in the vicinity of the areas of fit between them to absorb stresses occurring on fitting.

2. A two-piece stator having;

a generally annular inner stator core having a plurality of teeth extending radially outwardly from the outer surface thereof, an annular outer stator core having slots in the inner surface thereof for receiving the tips of said teeth, and coils provided around the bodies of said teeth respectively, before said inner and outer iron cores are combined by fit, and including channels formed in said inner surface adjacent said slots.

3. A two-piece stator as claimed in claim 2 wherein said channels are made so close to said slots that the stress caused by fitting said tips into said slots can be absorbed but so remote from said slots that the required engaging strength thereof with each said tip can be obtained.

4. A two-piece stator as claimed in claim 2 or 3 wherein a said channel is provided at one side of each slot in the circumferential sense.

5. A two-piece stator as claimed in claim 1, 2 or 3 wherein channels are provided on both side of each slot in the circumferential sense.

6. A two-piece stator having;
a generally annular inner stator core having a plurality of teeth extending radially outwardly from the outer surface thereof, an annular outer stator core having slots in the inner surface thereof for receiving the tips of said teeth, and coils provided around the bodies of said teeth respectively, before said inner and outer iron cores are combined by fit, and including channels formed in the tips of said teeth and extending substantially radially.

7. A two-piece stator as claimed in any preceding claim wherein said channel is filled with a deformable material.

8. A two-piece stator as claimed in claim 7, wherein said deformable material is magnetically soft material.

9. A two-piece stator constructed and arranged substantially as hereinbefore described with reference to and as illustrated in Figures 1 to 8 of the accompanying drawings.

10. A motor including a stator according to any preceding claim.