

(19) World Intellectual Property Organization
International Bureau



(43) International Publication Date
23 July 2009 (23.07.2009)

PCT

(10) International Publication Number
WO 2009/090232 A1

(51) International Patent Classification:

F23C 7/00 (2006.01) *F23L 7/00* (2006.01)
F23C 9/08 (2006.01) *F23D 14/32* (2006.01)

rue André Breton, F-91250 Saint Germain - Les - Corbeil
(FR).

(21) International Application Number:

PCT/EP2009/050454

(74) Agent: **CONAN, Philippe**; 75 Quai d'Orsay, F-75321
Paris Cedex 07 (FR).

(22) International Filing Date: 15 January 2009 (15.01.2009)

(25) Filing Language: English

(26) Publication Language: English

(30) Priority Data:

08305006.2 17 January 2008 (17.01.2008) EP

(81) Designated States (*unless otherwise indicated, for every kind of national protection available*): AE, AG, AL, AM, AO, AT, AU, AZ, BA, BB, BG, BH, BR, BW, BY, BZ, CA, CH, CN, CO, CR, CU, CZ, DE, DK, DM, DO, DZ, EC, EE, EG, ES, FI, GB, GD, GE, GH, GM, GT, HN, HR, HU, ID, IL, IN, IS, JP, KE, KG, KM, KN, KP, KR, KZ, LA, LC, LK, LR, LS, LT, LU, LY, MA, MD, ME, MG, MK, MN, MW, MX, MY, MZ, NA, NG, NI, NO, NZ, OM, PG, PH, PL, PT, RO, RS, RU, SC, SD, SE, SG, SK, SL, SM, ST, SV, SY, TJ, TM, TN, TR, TT, TZ, UA, UG, US, UZ, VC, VN, ZA, ZM, ZW.

(71) Applicant (*for all designated States except US*): **L'AIR LIQUIDE, SOCIÉTÉ ANONYME POUR L'ÉTUDE ET L'EXPLOITATION DES PROCÉDÉS GEORGES CLAUDE** [FR/FR]; 75 Quai d'Orsay, F-75007 Paris (FR).

(84) Designated States (*unless otherwise indicated, for every kind of regional protection available*): ARIPO (BW, GH, GM, KE, LS, MW, MZ, NA, SD, SL, SZ, TZ, UG, ZM, ZW), Eurasian (AM, AZ, BY, KG, KZ, MD, RU, TJ, TM), European (AT, BE, BG, CH, CY, CZ, DE, DK, EE, ES, FI, FR, GB, GR, HR, HU, IE, IS, IT, LT, LU, LV, MC, MK, MT, NL, NO, PL, PT, RO, SE, SI, SK, TR), OAPI (BF, BJ, CF, CG, CI, CM, GA, GN, GQ, GW, ML, MR, NE, SN, TD, TG).

(72) Inventors; and

(75) Inventors/Applicants (*for US only*): **SANCHEZ-MOLINERO, Ivan** [ES/FR]; 16, rue Saint-Louis, F-78000 Versailles (FR). **LAURENT, Jacky** [FR/FR]; 5, rue du Clos de la Fontaine, F-78210 Saint Cy L'ecole (FR). **MU-LON, Jacques** [FR/FR]; 1, Bld de la Paix, F-91300 Massy (FR). **PAUBEL, Xavier** [FR/FR]; 51, Avenue Jean Jaurès, F-92290 Chatenay Malabry (FR). **RECOURT, Patrick, Jean-Marie** [FR/FR]; 5, rue Toulouse Lautrec, F-91460 Marcoussis (FR). **TSIAVA, Rémi, Pierre** [FR/FR]; 71,

Published:

- *with international search report*
- *before the expiration of the time limit for amending the claims and to be republished in the event of receipt of amendments*

(54) Title: BURNER AND METHOD FOR IMPLEMENTING AN OXYCOMBUSTION

(57) Abstract: The invention relates to a method of combustion of a fuel using an oxygen containing gas and at least one mainly inert gas, in which: - the said oxygen containing gas comprises at least 80% of oxygen in volume, - the said fuel and the said oxygen containing gas are injected in such a way as to create a flame, - the said mainly inert gas is injected in such a way that it is contiguous to and surrounds the flame created by the said fuel and the said oxygen containing gas and that it has a divergent swirl with regard to the flame.



WO 2009/090232 A1

Burner and method for implementing an oxycombustion

5 The present invention relates to a burner and a combustion method which can make use of a high-oxygen-content gas.

10 With the increasingly stringent environmental restrictions, particularly in terms of the production of CO₂ and NO_x, the combustion of a fuel using oxygen or a high-oxygen-content gas is becoming increasingly attractive for the combustion of fossil fuels in all kinds of industry fields, where thermal fluids such as steam, hot water or hot oil, and/or electricity and/or mechanical work are needed. However, the conventional combustion devices using air as oxidizer do not always have the geometry, nor the requisite materials, for operating with oxygen or a high-oxygen-content gas. This is because the absence of the nitrogen ballast in high-oxygen or all-oxygen combustion significantly modifies the heat transfer modes, the species concentrations, and the pressure conditions in the combustion chamber.

15 In order to operate with all-oxygen combustion in these installations, one proposed solution is to reinject flue gas produced by the said combustion or another combustion to partly make up for the absence of nitrogen. This procedure serves to avoid a high production of NO_x due both to the absence of nitrogen, and also to a lower flame temperature than in all-oxygen combustion. However, the reinjected flue gas often nullifies the benefits of oxycombustion, such as, in particular, the lower proportion of unburnts from heavy oil residues, or the decrease of part of the ash, these unburnts and this ash then causing complications in the downstream flue gas treatment method.

20 This flue gas injection can be made essentially in two ways. First, by mixing the said flue gas with oxygen before its introduction into the burner, so as to reconstitute an oxidizer comprising about 21 to 27% oxygen and the remainder essentially consisting of CO₂ instead of nitrogen. One advantage that can be found for this solution in the case of a conversion of an air boiler is the possibility of retaining the air burners with minor operating adjustments. On the contrary, the premixing of the flue gases with the oxygen before their introduction into the burner may give rise to safety problems. To avoid this problem, in a second alternative, the flue gas can also be injected separately, either at a location of the combustion chamber, or through the burner. In the latter case, the flue gas is injected at a velocity such as to lengthen the flame, which may overheat the elements of the combustion chamber (opposite wall or tubes, in the case of a boiler). To avoid this problem, the flue gas injection velocities must be low, which has the effect of increasing the size of the burner and of creating layout problems, whereas it is well known that the surface areas of the combustion chamber must be maximized.

The preceding problems therefore imply the need to improve the methods and the oxycombustion burners making use of flue gas recycling.

Furthermore, practice demonstrates the utility of being able to use the combustion burners in flexible mode, that is, alternately in oxycombustion and in air combustion. In fact, owing to the restrictions in oxygen availability and/or safety problems, it may be useful to be able to convert an oxycombustion into air combustion without replacing the burner. Similarly, for certain types of combustion, it is preferable to start the combustion with air and then switch to oxycombustion for safety reasons.

It is therefore the object of the present invention to propose a device suitable for implementing an oxycombustion with flue gas recycle in a device designed for an air combustion.

A further object of the present invention is to propose a combustion device suitable for implementing an oxycombustion with flue gas recycle.

A further object of the present invention is to propose a combustion device suitable for implementing an oxycombustion with flue gas recycle the said combustions producing a flame having a controlled size.

For this purpose, the invention relates to a method of combustion of at least one fuel using at least one oxygen containing gas and at least one mainly inert gas, in which:

- the said oxygen containing gas comprises at least 80% of oxygen in volume,
- the said fuel and the said oxygen containing gas are injected in such a way as to create a flame,
- the said mainly inert gas is injected in such a way that it is contiguous to and surrounds the flame created by the said fuel and the said oxygen containing gas and that it has a divergent swirl with regard to the flame.

Other features and advantages of the invention will appear from a reading of the description that follows. Embodiments of the invention are provided as non-limiting examples, illustrated by the Figure 1 which is a schematic view of a burner according to the invention.

The method according to the invention implements the main combustion of a fuel by an oxygen containing gas. The fuel may be any gaseous, liquid, solid, slurry, emulsion, or any combination thereof. If it is a gas, the fuel may be, but is not limited to, natural gas,

mine gas, coke oven gas, blast furnace gas, refinery gas, low heating value gas, gassified solid fuel, or syngas. If it is a liquid, the fuel may be, but is not limited to, home-heating oil, heavy fuel oil, asphalt, refinery residue or crude oil. If it is a solid, the fuel may be, but is not limited to, coal, coke, petroleum coke, biomass, peat, solid asphalt, or solid refinery residue. These various types of fuels are injected in such a way as to form a flame with the oxygen containing gas. The injections of the fuel or fuels and the oxygen containing gas can be made in any manner known to a person skilled in the art in order to produce a flame. According to the method of the invention, a mainly inert gas is also injected. The mainly inert gas comprises at least one of the following compounds: CO₂, H₂O, Ar, in a molar quantity of at least 50%. The mainly inert gas may be or comprise a flue gas.

The mainly inert gas is preferably injected in the form of a single jet. This single jet surrounds the flame created by the fuel and the oxygen containing gas. In the context of the present invention, "surround" means the fact that this jet of mainly inert gas encircles the central flame of the fuel and the oxygen containing gas. According to a preferred embodiment, the jet of mainly inert gas has the shape of a ring centred on the flame of fuel and oxygen containing gas.

According to the invention, the single peripheral jet has a divergent swirl with regard to the flame of fuel and oxygen containing gas. In the context of the present invention, swirl of a jet means a swirl movement of the jet about itself. The single peripheral jet is therefore a jet swirling about itself. Since the said jet surrounds the flame of fuel and oxygen containing gas, the said single peripheral jet is also swirling about the said flame. According to the invention, this swirl is divergent, that is, in the single peripheral jet, the mainly inert gas moves away from the flame of fuel and oxygen containing gas as it is injected.

For the single peripheral jet, the swirl rate of each of this jet of mainly inert gas is advantageously between 0.26 and 1.73. The swirl rate S is defined as follows: $S = l_t/l_a$, where l_t and l_a are respectively the tangential and axial pulses of the fluid swirled in a jet.

The method is particularly suited for use in boilers.

In the context of the present invention, oxygen-containing gas preferably means a gas having an oxygen concentration above 90% in volume. According to this embodiment, the oxidizer is an oxygen-containing gas and the mainly inert gas is composed of the flue gases from a combustion. The flue gases from a combustion generally comprise mainly, if not exclusively, CO₂. These gases may also comprise H₂O. Preferably, the mainly inert gas consists at least partly of the gases issuing from the combustion of the present method and which are recycled during the combustion method. In this case, the flue gases are recycled outside the combustion chamber in which the present method is implemented. They may be treated before being recycled. In general, at least 4 Sm³ of

flue gases are recycled during the method according to the invention. According to this embodiment, it is preferable for the flow rate of mainly inert gas injected into the single peripheral jet of mainly inert gas to account for 100% of the total flow rate of mainly inert gas injected. Furthermore, the gases issuing from a combustion injected in the form of the single peripheral jet does not disturb the flame issuing from the combustion of the fuel and of the oxygen-containing gas, but creates a corridor close to the nose of the burner which protects the walls of the combustion chamber from excessively intense radiation. Beyond the burner nose, the gases issuing from a combustion and injected in the form of the single peripheral jet and the hot gases issuing from the actual combustion of the method, are mixed to form only one uniform mixture. According to a first embodiment, gases issuing from a combustion may also be injected into at least one point of the combustion chamber that is different from the injection points of the single peripheral jet.

The invention also relates to a burner suitable for implementing the said method, which comprises:

- at least one means for injecting said fuel and at least one means for injecting said oxygen containing gas comprising at least 80% of oxygen in volume, the said means being placed with regard to one another in such a way that the oxygen containing gas and the fuel are capable of producing a flame,
- a means for injecting said mainly inert gas:
- said means for injecting the said mainly inert gas being suitable for injecting it in the form of a jet contiguous to and surrounding the flame produced by the said oxygen containing gas and the said fuel, and said means for injecting the said mainly inert gas comprising a means suitable for divergently swirling the flow of said mainly inert gas passing through it.

The burner according to the invention therefore comprises a first central part comprising at least one means for injecting fuel and at least one means for injecting the oxygen containing gas. These two injection means must be positioned with regard to one another in such a way that the oxygen containing gas and fuel are capable of producing a flame when the burner operates. Thus the means for injecting fuel and oxygen containing gas may be coaxial tubes or separate tubes. Any known technique for injecting fuel and oxygen containing gas in order to form a flame can be used.

The burner comprises a second peripheral part consisting of a means for injecting mainly inert gas. Preferably, the means suitable for divergently swirling the flows of mainly inert gas passing through the injection means causes the said flow to swirl with a swirl rate of between 0.26 and 1.73. The said means suitable for divergent swirling is generally a deflector.

According to a particular embodiment, the burner is such that:

- the means for injecting mainly inert gas comprises two coaxial tubes centred around the means for injecting fuel and the means for injecting an oxygen containing gas, the space between the two tubes allowing the passage of part of the mainly inert gas and comprising the means suitable for divergently swirling the flow of mainly inert gas passing through it.

According to this particular embodiment, the burner may also comprise two means for injecting oxygen containing gas, the said means being coaxial tubes, and the means for injecting fuel may be a metal ring drilled with at least one ring of orifices, the said metal ring being coaxial with the oxygen containing gas injection tubes and placed between the said tubes. The burner is then composed of four coaxial tubes and the metal ring drilled with orifices arranged in a ring, the said ring being placed between the smallest tube and the tube having the immediately larger diameter.

According to the invention, the burner may comprise two distinct means for injecting fuel for the injection of two different fuels.

Figure 1 shows the end of a burner according to the invention. It comprises a first central part consisting of:

- fuel injection means 1 which is a tube,
- oxygen containing gas injection means 2 which comprises two tubes 21 and 22: one 21 is placed at the centre of the fuel injection tube 1 and the other 22 around the same fuel injection tube 1.

The burner also comprises a second part which is a means for injecting mainly inert gas; it comprises two coaxial tubes 22, 31, centred on the first central part, the smallest tube corresponding to the tube 22 for injecting fuel 1. The space between the intermediate tube 31 and the smallest tube 22 comprises means 5 (fins) suitable for divergently swirling the flow of mainly inert gas passing through it.

One advantage of the invention is that it may serve to modify a burner normally operating with air in such a way that it operates with an oxygen-containing gas and oxygen-containing flue gases. It suffices to supplement the air burner corresponding to the first part of the burner according to the invention with the second part of the burner according to the invention suitable for injecting the recycled flue gases. The oxygen-containing gas is then injected into the first part of the burner and the flue gases are injected into the second part.

One advantage of the burner and of the combustion method according to the invention is that they produce a flame having a controlled size, which is useful in confined vessels, such as boiler combustion chambers in which the direct contact of the

excessively long flame with bare steel tubes is fatal. In this latter case, the geometry of the flame produced by the burner according to the invention allows a uniform distribution of the heat flux on all the inner surfaces of the boiler; a boiler equipped with this burner operating in oxycombustion can withstand an energy density of up to 0.600 MW/m³ depending on the proportion of flue gas recycled.

A further advantage of the burner and of the combustion method according to the invention operating with an oxygen-containing gas is that they produce a flame having a high core temperature, whereby the unburnts are significantly decreased.

This invention may comprise one or more of the following features :

The fuel may be gaseous, liquid, solid, a slurry, an emulsion, solid in gas suspension, or any combination of the above. Three or more different fuels may be simultaneously injected. The fuel is injected through two or more orifices and the oxygen containing gas injected through two or more orifices. The oxygen containing gas is injected through two or more orifices. The injection of the oxygen containing gas is staged between primary and secondary oxygen. A single set of orifices may be utilized to inject two or more different fuels. The flue gas temperature is maintained at a temperature greater than the acid dew point temperature.

The pressure drop that either the fuel stream, oxygen containing gas stream, or both, experiences upon passing through the burner may be no more than 200 mbar. The pressure drop that the mainly inert gas experiences when passing through the burner may be between 4 mbar and 10 mbar. The mainly inert gas injection means may be fabricated from HR 160, or another Hastelloy-type alloy, if the fuel has a high sulphur content. The mainly inert gas injection means may be fabricated from 316 stainless steel if the fuel is relatively sulphur free. The means for injecting oxidant and fuel may be fabricated from Inconel 600. A boiler may comprise at least one burner in accordance with this design.

The oxidizer is an oxygen-containing gas and the mainly inert gas is composed of the gases issuing from a combustion of said method and recycled, wherein the **rate of recycling** varies from 0.1 to 5.0, preferably 1.5. In this document, the rate of recycling is defined as the ratio (x/y) of the volume flowrate of the flue gas that is recycled (x) to the volume flowrate of the flue gas that exists the system through the stack (y).

In a another embodiment, the method of combustion according to the invention is used to produce at least one thermal fluid, for example steam, hot water or hot oil and/or electricity and /or mechanical work.

CLAIMS

1. Method of combustion of at least one fuel using at least one oxygen containing gas and at least one mainly inert gas, in which:
- 5 - the said oxygen containing gas comprises at least 80% of oxygen in volume,
- the said fuel and the said oxygen containing gas are injected in such a way as to create a flame,
- the said mainly inert gas is injected in such a way that it is contiguous to and surrounds the flame created by the said fuel and the said oxygen containing gas and that it has a
10 divergent swirl with regard to the flame.
2. Method according to one of the preceding claims, characterized in that the fuel may be gaseous, liquid, solid, a slurry, an emulsion, solid in gas suspension, or any combination of the above.
- 15
3. Method according to one of the preceding claims, characterized in that 3 or more different fuels may be simultaneously injected.
4. Method according to one of the preceding claims, characterized in that the fuel is
20 injected through two or more orifices and the oxygen containing gas injected through two or more orifices.
5. Method according to one of the preceding claims, characterized in that the oxygen containing gas injected through two or more orifices.
- 25
6. Method according to one of the preceding claims, characterized in that the injection of the oxygen containing gas is staged between primary and secondary oxygen.
7. Method according to one of the preceding claims, characterized in that a single set of
30 orifices may be utilized to inject two or more different fuels.
8. Method according to one of the preceding claims, characterized in that the mainly inert gas is composed of the gases issuing from a combustion of said method and recycled, wherein the rate of recycling varies from 0.1 to 5.0, preferably 1.5.
- 35
9. Method according to one of the preceding claims, characterized in that the flue gas temperature is maintained at a temperature greater than the acid dew point temperature.

10. Burner comprising:

- at least one means (1) for injecting fuel and at least one means for injecting an oxygen containing gas comprising at least 80% of oxygen in volume, the said means being placed
5 with regard to one another in such a way that the oxygen containing gas and the fuel are capable of producing a flame,

- a means for injecting a mainly inert gas:

said means for injecting the mainly inert gas being suitable for injecting the mainly inert
10 gas in the form of a jet contiguous to and surrounding the flame produced by the oxygen containing gas and the fuel, said means for injecting the mainly inert gas comprising a means (5) suitable for divergently swirling the flow of mainly inert gas passing through it.

11. Boiler comprising at least one burner according to claim 10.

15 12. Use of the method of combustion according to claim 1 in order to produce at least one thermal fluid, for example steam, hot water or hot oil and/or electricity and /or mechanical work.

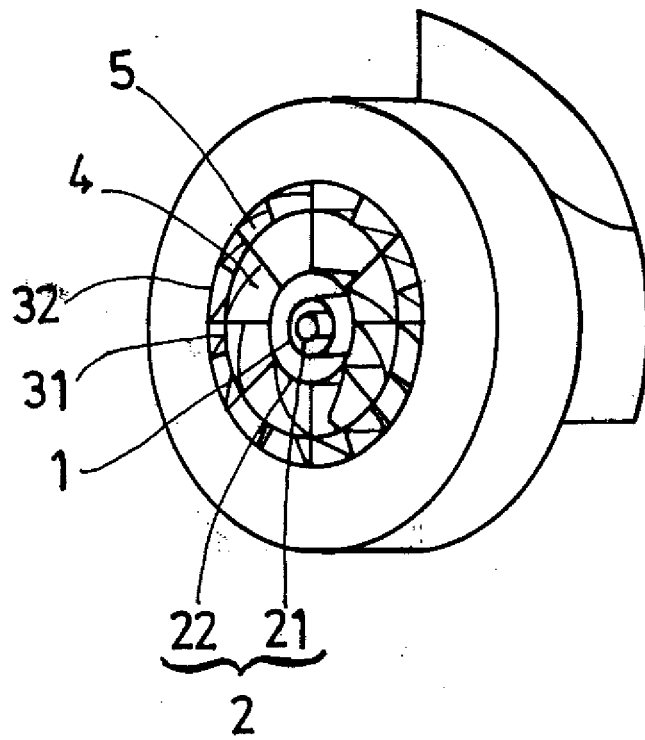

FIG.1

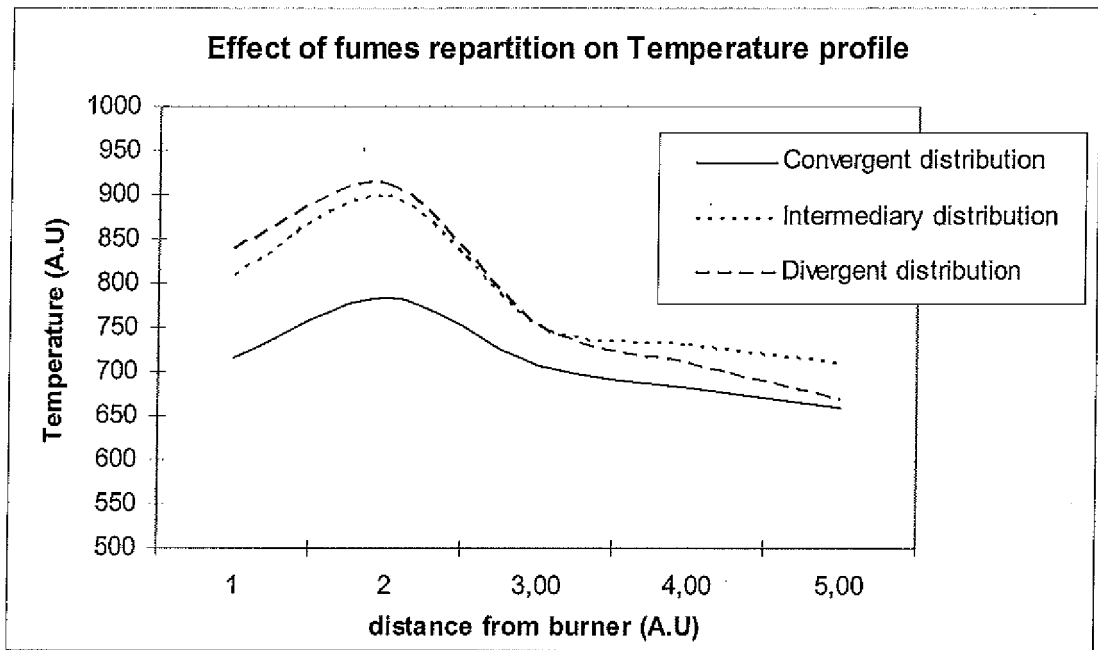

Fig. 2

INTERNATIONAL SEARCH REPORT

International application No
PCT/EP2009/050454

A. CLASSIFICATION OF SUBJECT MATTER
 INV. F23C7/00 F23C9/08 F23L7/00 F23D14/32

According to International Patent Classification (IPC) or to both national classification and IPC

B. FIELDS SEARCHED
 Minimum documentation searched (classification system followed by classification symbols)
 F23C F23L F23D

Documentation searched other than minimum documentation to the extent that such documents are included in the fields searched

Electronic data base consulted during the international search (name of data base and, where practical, search terms used)
 EPO-Internal

Category*	Citation of document, with indication, where appropriate, of the relevant passages	Relevant to claim No.
A	WO 2004/029511 A (LINDE AG [DE]; LUGNET ANDERS [SE]; EKMAN TOMAS [SE]) 8 April 2004 (2004-04-08) page 4, line 14 - page 5, line 31; claim 1; figure 1	1,10
A	EP 1 517 085 A (PRAXAIR TECHNOLOGY INC [US]) 23 March 2005 (2005-03-23) paragraphs [0079], [0080], [0082], [0090], [0098], [0104]; figure 2	1,2, 10-12
A	US 4 545 307 A (MORITA SHIGEKI [JP] ET AL) 8 October 1985 (1985-10-08) column 3, lines 35-51 column 4, line 52 - column 5, line 56 column 6, lines 58-65; figures 2-5	1,2, 10-12
	----- -/--	

Further documents are listed in the continuation of Box C.

See patent family annex.

- * Special categories of cited documents :
- *A* document defining the general state of the art which is not considered to be of particular relevance
 - *E* earlier document but published on or after the international filing date
 - *L* document which may throw doubts on priority claim(s) or which is cited to establish the publication date of another citation or other special reason (as specified)
 - *O* document referring to an oral disclosure, use, exhibition or other means
 - *P* document published prior to the international filing date but later than the priority date claimed
 - *T* later document published after the international filing date or priority date and not in conflict with the application but cited to understand the principle or theory underlying the invention
 - *X* document of particular relevance; the claimed invention cannot be considered novel or cannot be considered to involve an inventive step when the document is taken alone
 - *Y* document of particular relevance; the claimed invention cannot be considered to involve an inventive step when the document is combined with one or more other such documents, such combination being obvious to a person skilled in the art.
 - * & * document member of the same patent family

Date of the actual completion of the international search 11 May 2009	Date of mailing of the international search report 18/05/2009
--	--

Name and mailing address of the ISA/ European Patent Office, P.B. 5818 Patentlaan 2 NL - 2280 HV Rijswijk Tel. (+31-70) 340-2040, Fax (+31-70) 340-3016	Authorized officer Coli, Enrico
---	--

1

INTERNATIONAL SEARCH REPORT

International application No
PCT/EP 2009/050454

C(Continuation). DOCUMENTS CONSIDERED TO BE RELEVANT		
Category*	Citation of document, with indication, where appropriate, of the relevant passages	Relevant to claim No.
A	EP 0 644 374 A (BOC GROUP INC [US]) 22 March 1995 (1995-03-22) column 4, line 20 - column 5, line 24; figures 1,2	1
A	----- US 4 412 810 A (IZUHA AKIRA [JP] ET AL) 1 November 1983 (1983-11-01) -----	

INTERNATIONAL SEARCH REPORT

Information on patent family members

International application No

PCT/EP2009/050454

Patent document cited in search report		Publication date	Patent family member(s)	Publication date
WO 2004029511	A	08-04-2004	AU 2003263721	A1 19-04-2004
			BR 0314741	A 26-07-2005
			CA 2501062	A1 08-04-2004
			EP 1543271	A1 22-06-2005
			JP 2006500543	T 05-01-2006
			KR 20050062556	A 23-06-2005
			MX PA05003198	A 12-09-2005
			US 2005239005	A1 27-10-2005
			ZA 200502379	A 24-10-2005
EP 1517085	A	23-03-2005	AU 2004212517	A1 07-04-2005
			CA 2481617	A1 16-03-2005
			CN 1598401	A 23-03-2005
			JP 2005134102	A 26-05-2005
			KR 20050027939	A 21-03-2005
			MX PA04009014	A 08-09-2005
			US 2005058958	A1 17-03-2005
US 4545307	A	08-10-1985	AU 570249	B2 10-03-1988
			AU 2915684	A 31-10-1985
			DE 3485248	D1 12-12-1991
			EP 0160146	A2 06-11-1985
			FI 851263	A 24-10-1985
			IN 164394	A1 11-03-1989
			JP 1750459	C 08-04-1993
			JP 4039564	B 30-06-1992
			JP 60226609	A 11-11-1985
			NO 851597	A 24-10-1985
			ZA 8501121	A 30-10-1985
EP 0644374	A	22-03-1995	AU 684296	B2 11-12-1997
			AU 7295994	A 30-03-1995
			CA 2129916	A1 16-03-1995
			CN 1108372	A 13-09-1995
			DE 69406080	D1 13-11-1997
			DE 69406080	T2 05-02-1998
			JP 7151306	A 13-06-1995
			US 5454712	A 03-10-1995
			ZA 9406332	A 27-06-1995
US 4412810	A	01-11-1983	NONE	