



(11) **EP 1 670 366 B1**

(12) **EUROPEAN PATENT SPECIFICATION**

(45) Date of publication and mention of the grant of the patent:  
**04.04.2018 Bulletin 2018/14**

(21) Application number: **04817773.7**

(22) Date of filing: **12.10.2004**

(51) Int Cl.:  
**A61B 17/132 (2006.01)**

(86) International application number:  
**PCT/US2004/030918**

(87) International publication number:  
**WO 2005/053506 (16.06.2005 Gazette 2005/24)**

(54) **MECHANICAL ADVANTAGE TOURNIQUET**

STAUMANSCHETTE MIT MECHANISCHER ÜBERSETZUNG

GARROT PRESENTANT UN AVANTAGE MÉCANIQUE

(84) Designated Contracting States:  
**AT BE BG CH CY CZ DE DK EE ES FI FR GB GR HU IE IT LI LU MC NL PL PT RO SE SI SK TR**

(30) Priority: **10.10.2003 US 509917 P**  
**04.10.2004 US 615027 P**

(43) Date of publication of application:  
**21.06.2006 Bulletin 2006/25**

(73) Proprietor: **Pyng Medical Corp.**  
**Richmond, BC V64 2E9 (CA)**

(72) Inventors:  
• **HEINZ, Thomas J.**  
**La Canada, CA 91011 (US)**  
• **RUMSEY, Royce**  
**Laguna Beach, CA 92651 (US)**

• **BANNISTER, Ed**  
**Victorville, CA 82392 (US)**  
• **CHAN, Sai Chung**  
**Irvine, CA 92606 (US)**

(74) Representative: **Denemeyer & Associates S.A.**  
**Postfach 70 04 25**  
**81304 München (DE)**

(56) References cited:  
**DE-A1- 3 133 793**                      **GB-A- 2 027 149**  
**US-A- 2 035 952**                      **US-A- 4 102 343**  
**US-A- 4 243 039**                      **US-A- 5 312 350**  
**US-A1- 2004 260 211**                **US-B1- 6 960 223**  
**US-B2- 6 688 260**                      **US-B2- 6 884 254**

**EP 1 670 366 B1**

Note: Within nine months of the publication of the mention of the grant of the European patent in the European Patent Bulletin, any person may give notice to the European Patent Office of opposition to that patent, in accordance with the Implementing Regulations. Notice of opposition shall not be deemed to have been filed until the opposition fee has been paid. (Art. 99(1) European Patent Convention).

## Description

### BACKGROUND OF THE INVENTION

#### Field of the Invention

**[0001]** The present invention relates to a tourniquet with an improved tightening system that provides a mechanical advantage for applying a compression force to an appendage.

#### Description of the Related Art

**[0002]** A tourniquet is a device for temporarily controlling the flow of blood through or from a large artery in an appendage under emergency conditions as the tourniquet cuts off the blood supply to the appendage for a period of time. Although primarily used as a first-aid or triage measure, tourniquets can also be used in a medical facility during surgical procedures.

**[0003]** To be effective, a tourniquet must be tight enough to stop the arterial blood flow to the appendage. However, a tourniquet is often applied as an emergency measure by individuals with knowledge that a tourniquet must be used, yet without experience in the level of medical care to properly apply the tourniquet and effectively restrict the flow of blood. In many emergency situations, tourniquets are an improvised form of treatment taking the form of a cloth rag being tied to the injured appendage. The state of mind in which individuals applying and/or receiving the tourniquet may find themselves include shock, anxiety and desperation.

**[0004]** Further, environmental conditions, such as the rain, snow, sandstorm, or dust storm also affect the efficiency with which a tourniquet can be applied to an injured appendage.

**[0005]** In DE 3133793A1, there is described a pressure control apparatus according to the preamble of claim 1. DE 3133793A1 describes apparatus for restricting a flow of blood to or from a body part.

**[0006]** US 4243039 discloses an emergency tourniquet comprising a strap and a combined mechanism for tightening the strap indicating the pressure applied to a limb.

**[0007]** GB2027149A discloses a ligature device comprising a band that can be pulled through a housing to tighten it.

**[0008]** It is against the background, and the limitations and problems associated therewith, that the present invention has been developed.

### SUMMARY OF THE INVENTION

**[0009]** To achieve this, the pressure control apparatus of the invention comprises the features claimed in the characterizing part of claim 1.

**[0010]** The present invention relates to a new type of tourniquet for use in emergency medicine, either in the

field or at a medical facility. The present invention stops or restricts the flow of blood between the heart and an injured appendage by applying sustained pressure to the appendage between the heart and the injury.

**[0011]** One embodiment of the present invention takes into consideration that a user of the invention may be, for example, a hiker or backpacker, mountain climber, merchant seaman, vehicular or industrial accident or natural disaster victim, or a soldier in the battlefield, and the unique environmental circumstances and physical impediments that these individuals may face when injured or wounded.

**[0012]** Using the soldier as an example, the mechanical advantage tourniquet is designed for a fast and easy application as required by the soldier under tremendous pressure and/or in shock, and the need to quickly apply and tighten a tourniquet on his own body, with possibly one hand, in approximately five seconds. As such, the device is a continuous strap, and not pre-looped to allow use in the field by a soldier whose leg or legs may be trapped or obstructed. The bionics of the mechanical advantage tourniquet of the present invention, can more efficiently and effectively compress an injured appendage, thereby temporarily stopping the flow of blood.

**[0013]** The tourniquet of the present invention is lightweight and portable so that it can be carried in a pocket of a soldier's uniform and is designed so that a weak and/or wounded soldier can apply it in the field or under combat conditions. For example, the soldier can apply the tourniquet while wearing gloves and the tourniquet is effective over rain and snow gear. Further the tourniquet can have luminescent markings to make it easy to use in at night or in a darkened environment. The tourniquet is also self-contained with no additional pieces or assembly required. Further, the tourniquet can be easily and successfully applied to the body under adverse weather conditions, such as in extreme temperatures ranging from at least -40 degrees to 51,67 degrees Celsius (-40 degrees to 125 degrees F), in and around ice, snow, rain, mud, saltwater, blowing sand and dirt, and other environmental obstacles. The tourniquet can also withstand all standard consumer product impact tests.

**[0014]** The present invention includes a tourniquet or pressure control apparatus for restricting a flow of blood through or from a body part, according to appended claim 1, the apparatus including at least one arcuate member which can be a base member or a C-clip, for example, for attaching to the body part. The arcuate member has a first end and an opposite second end. A primary tightening device including a mechanical advantage power system can be mounted on the at least one arcuate member for adjusting a pressure of the apparatus on the body part. A secondary tightening device or cinch strap can be disposed on at least a portion of the arcuate member for circumferentially tightening the apparatus on the body part. A locking device can securely close the apparatus around the body part by being attached to the arcuate member.

**[0015]** The primary tightening device includes a mechanical advantage power system that can multiply an output force while minimizing the input force needed to create the output force. Such mechanical advantage power systems include, but are not limited to pulleys, eyelets, post systems, needle bobbins, gears, levers, wheels, and cams.

**[0016]** The present invention also includes the use of a pressure control apparatus for restricting the flow of blood through or from a body part according to appended claim 28. The apparatus has at least one arcuate member that can be mounted on or attached to the body part. The one arcuate member has a rear end portion and a front end portion so that a primary tightening device can be mounted on the front end portion and a secondary tightening device can be mounted on the rear end portion. The primary tightening device adjusts a pressure of the apparatus on the body part. The secondary tightening device circumferentially tightens the apparatus on the body part. A locking device closes the apparatus around the body part, and is attached to the arcuate member. The use of the apparatus includes placing the arcuate member and the secondary tightening device around the body part to be treated; threading the secondary tightening device through the locking device, and over a second end of the at least one arcuate member or engagement of a pre-threaded tightening device with the second end of the at least one arcuate member to allow for one-handed application; setting the locking device to clasp the external ends of the second end of the at least one arcuate member; pulling the secondary tightening device in a direction tangent to the at least one arcuate member until the secondary tightening device is secured tightly to the body part; raising the turnkey from a horizontal position to a vertical position; turning the turnkey in a predetermined direction until the primary tightening device can no longer be turned; and folding the turnkey to a horizontal position.

**[0017]** The present invention further includes a pressure control apparatus for restricting a flow of blood through or from a body part having mounting means for mounting the pressure control apparatus on the body part to be treated. Tightening means are attached to the mounting means for tightening the pressure control apparatus onto the body part to be treated. Locking means are operatively connected to the tightening means for locking the pressure control apparatus onto the body part to be treated.

#### BRIEF DESCRIPTION OF THE DRAWINGS

**[0018]** The features of the invention will be more readily understood with reference to the following description and the attached drawings, wherein:

Figure 1 illustrates a side view of the tourniquet according to a first embodiment of the present invention;

Figure 2 illustrates a top view of the tourniquet mechanical advantage power system according to a first embodiment of the present invention;

Figure 3 illustrates a top perspective view of the tourniquet according to a second embodiment of the present invention, as applied to an appendage;

Figure 4 illustrates a side view of the tourniquet C-clip member according to a second embodiment of the present invention;

Figure 5 illustrates a front perspective view of the tourniquet C-clip member according to a second embodiment of the present invention;

Figure 6 illustrates a side view of the tourniquet C-clip member and integral mechanical advantage power system and attached platen according to a second embodiment of the present invention;

Figure 7 illustrates an exemplary interior view of a mechanical advantage power system housing according to a second embodiment of the present invention;

Figure 8 illustrates an exemplary top-rear perspective view of the mechanical advantage power system components on the tourniquet C-clip member according to a second embodiment of the present invention;

Figure 9 illustrates an exemplary rear view of the mechanical advantage power system components on the C-clip member of the tourniquet according to a second embodiment of the present invention;

Figures 10 and 11 illustrate an exemplary top view of the housing and release button of the mechanical advantage power system according to a second embodiment of the present invention;

Figure 12 illustrates an exemplary winch and engaged pawl arrangement of the mechanical advantage power system according to a second embodiment of the present invention; and

Figure 13 illustrates an exemplary winch and released pawl arrangement of the mechanical advantage power system according to a second embodiment of the present invention.

#### DETAILED DESCRIPTION OF INVENTION

**[0019]** Figure 1 illustrates a side view of the mechanical advantage tourniquet 10 according to a first embodiment of the present invention. As shown in Figure 1, the tourniquet 10 includes a mechanical advantage power system 8, an arcuate member or base 2, a strap 12, and a locking member 20.

**[0020]** The base 2 has a first end 4 and a second end 6, and serves as a mounting means for mounting the tourniquet 10 onto the injured appendage. The base 2 can be formed from a flexible material, including but not limited to, a polymeric material such as acetal or nylon.

**[0021]** The strap 12, such as a cinch strap is an elongated member that can also be formed from any suitably flexible material including, but not limited to, nylon. The

strap 12 extends from the first end 4 of the base 2 around the injured appendage where it is threaded through and locked into place by the locking member 20. In combination, the strap 12, along with the mechanical advantage power system 8, serve as tightening means for tightening the tourniquet on the injured appendage.

**[0022]** Figure 1 illustrates the mechanical advantage power system 8, which is a device that can multiply an output force while reducing an input force needed to create the output force. Thus, the mechanical advantage power system 8 allows any size user to simply and easily adjust and tighten the tourniquet 10 onto the appendage with minimum effort. The power system 8 creates a mechanical advantage-assisted tension that cuts off the blood supply to an appendage once the strap 12 encircling the appendage has been pulled tight and locked into place by the locking member 20. As shown in Figure 1, the mechanical advantage power system 8 is mounted onto the base 2 between the first end 4 and the second end 6 of the base. The power system 8 includes components designed to apply a controlled pressure to the injured appendage, and thereby restrict the flow of blood through or from the injury on the appendage. The components include a graduated track 34 integrally formed on an outer surface of the base 2, at least one platen 24 disposed on the track 34 at the first end 4 having a plurality of posts 26a, 26b; a winding cord 28; a winch or cord retracting device 42; and a turnkey 16. The winch 42 is disposed on a second end 6 of the base 2, and the turnkey 16, shown in a folded down locked position in Figures 1 and 2, is pivotally mounted onto the winch 42 to rotate the winch. The graduated track 34 allows the platen 24 of the base 2, to slide along the perimeter of the base 2.

**[0023]** The platen 24 can be formed from any polymeric material, including but not limited to acetal and nylon. The platen 24 secures one end of the strap 12 at the first end 4 of the base 2. A first set of linearly arranged posts 26a project from the platen 24 to anchor a braided or interwoven winding cord 28. A second set of posts that may be directly mounted onto the base 2 or project from a second platen 24, provide a guide for the cord 28. The winding cord 28 is wound around the posts 26a, 26b and the winch 42, and threaded through an opening in the winch 42 in a serpentine manner, as shown on Figure 2. Turning the turnkey 16 rotates the winch 42 causing the cord 28 to wrap around the winch, and pulls the cord 28 into tension between the platen 24 and the winch 42, thereby providing a mechanical advantage for tightening the tourniquet on the appendage.

**[0024]** The turnkey 16 can have any shape that is easy for a user to grip between the fingers and can include, for example, a D-ring style handle as shown in Figure 2. The turnkey 16 is capable of rotating 360° and pivoting 90°.

**[0025]** The locking member 20 shown in Figures 1 and 2, is pivotally connected to the base 2 by a pair of hinges (not shown) mounted on opposite lateral sides of the base

2. The locking member 20 serves to lock the winch 42 in position when the desired level of pressure on the appendage is achieved. The locking member 20 also serves as a means for locking the strap 12 in place on the tourniquet. The locking member 20 is formed with a ring portion at one end and a locking lever 22 at an opposite end. The locking lever 22 is operatively connected to a lateral shaft on the second end 6 of the base 2 so that the locking lever 22 of the locking member 20 can be clasped and unclasped from the second end 6 of the base 2 as shown in Figure 1. A free end 18 of the strap 12 can be threaded through the ring portion of the locking member 20, folded back over the strap 12, and pulled to tightly and securely position the strap 12 on the appendage. The strap 12 can then be locked into place on the tourniquet by pivoting the locking lever 22 downward.

**[0026]** A protective accordion-style bellows 14, shown in Figure 1, covers the sliding platen 24, cord 28, posts 26a, 26b and winch 42 of the power system 8. The bellows 14 are flexible and capable of expanding and contracting in at least the longitudinal direction of the tourniquet based on the sliding movement of the platen 24. The bellows 14 can be formed from a polymeric material such as neoprene.

**[0027]** As shown in Figure 2, the strap 12 is connected to the power system 8 and turnkey 16. The strap 12 can be a cinch strap approximately 2,54 to 6,35 cm (1 to 2-1/2 inches) wide, and 76,2 cm (30 inches) or more in length. The strap can be made of, for example only, nylon or any suitable polymeric material, and have ribbing on at least one side to help secure the strap in place against the power system 8. The free end 18 of the strap 12 can include a feeder or gripping portion help the user attain a firm grasp on the strap 12. Heating a nylon strap to the point where the fibers are fused together can form the gripping portion.

**[0028]** One exemplary method of restricting the flow of blood through or from an injured appendage, may include: placing the base 2 on the appendage and encircling the appendage with the strap 12; threading the free end 18 of the strap 12 through the locking member ring and pulling down slowly and firmly until the strap 12 is secured tightly onto the appendage; pivoting the locking lever 22 downwardly over the free end 18 of the strap 12 to lock the strap in place; pivoting the turnkey 16, to an upright position so as to be vertical with respect to the base 2, and turning the turnkey 16 clockwise to thereby pull the cord 28 into tension between the platen 24 and the winch 42, until the turnkey 16, and therefore the winch 42 can no longer be turned. As a result, pressure on the appendage is increased. The turnkey 16 can then be pivoted to a horizontal position. Folding the locking member 20 over the winch 42 prevents the winch 42 from accidentally rotating.

**[0029]** One example of releasing pressure on the appendage or removing the tourniquet includes: loosening the cord 28 in the power system 8 by lifting the locking member 20 which will result in disengagement of the

winch, then pivoting the turnkey 16 from a horizontal position to an upright position so as to be vertical with respect to the base; turning the turnkey 16 in a counter-clockwise direction to rotate the underlying winch 42 in the reverse direction to release the tension between the platen 24 and the winch 42, and thereby pressure on the appendage; sliding the free end 18 of the strap 12 toward the locking member ring. As a result, the tourniquet 10 can be adjusted on or removed from the appendage. The tourniquet of the present invention is reusable in that it can be removed, loosened, and reapplied.

**[0030]** Figures 3-6 illustrate the mechanical advantage tourniquet 110 according to a second embodiment of the present invention, which includes components designed to apply a controlled pressure to the injured appendage and thereby restrict the flow of blood through or from the injury. As disclosed above, the mechanical advantage is a device that can multiply an output force while reducing an input force needed to create the output force. Figure 3 illustrates the mechanical advantage tourniquet 110 as it can be applied to an injured appendage. The tourniquet 110 includes an arcuate member or C-clip 102 on which is mounted a mechanical advantage power system 108 having a tightening turnkey 116 for activating the mechanical advantage, and a release button 130 for canceling the mechanical advantage, a strap 112, and a locking member 120.

**[0031]** A shroud 114, shown in Figure 3, is a sleeve-like member that extends circumferentially around an outer surface of the C-clip 102 and acts as a barrier to prevent foreign elements entering the power system 108. The shroud 114 can be diametrically cut such that the inside portion is shorter than the outside portion, lending an arcuate shape to the body of the shroud. The shroud or cover 114 is disposed over a portion of the mechanical advantage power system 108 leaving the tightening turnkey 116 exposed. Additional mechanical advantage components are disposed underneath the shroud 114, and will be discussed below.

**[0032]** The mechanical advantage power system 108 creates a mechanical advantage-assisted tension that cuts off the blood supply to an appendage once the strap 112 encircling the appendage has been pulled tight and locked into place by the locking member 120. In combination, the strap 112, along with the mechanical advantage power system 108 mounted onto the C-clip 102, serve as tightening means for tightening the tourniquet on the injured appendage.

**[0033]** As shown in Figure 3, the C-clip 102 is placed onto the appendage. The strap 112 extends from a rear end portion of the C-clip 102, circumscribes the appendage, and fastens to a front end portion of the C-clip 102 with a locking member 120. The C-clip will now be discussed with reference to Figures 4-6.

**[0034]** Figure 4 illustrates a side view of the C-clip 102 according to a second embodiment of the present invention. The C-clip 102 is the innermost portion of the mechanical advantage tourniquet 110 and directly contacts

the appendage or body part in which the flow of blood is to be restricted. As such, the C-clip 102 serves as a mounting means for mounting the tourniquet 110 onto the injured appendage. The C-clip is flexible and can be made by any means, including for example, injection molding a polymeric material. The polymeric material can include, but is not limited to acetate, nylon, polypropylene, and polyethylene. As such, the C-clip can be made from a material having an elastic memory so that the C-clip can circumferentially open and then return to its original state. Due to its flexibility and elasticity, the C-clip can fit various sizes of appendages. As shown in Figures 4 and 5, the C-clip includes a hook 100 with detent 122 at the front end of the C-clip 102. The hook 100 of the C-clip is flared so as to relieve hot spotting during construction. The C-clip 102 also has protrusions 136 forming a crenellated inner surface for gripping the surface of an appendage. A strap guide 150 is mounted along an outer surface of the C-clip 102 to guide the strap 112 from the rear end portion of the C-clip to a front end portion.

**[0035]** The tightening turnkey 116, shown in an upright position in Figures 4 and 5, is secured to a winch or cord retracting device 142. By turning the turnkey 116, the winch 142 rotates and pulls a winding cord that extends from the platen 124 to the winch 142 into tension, thereby providing a mechanical advantage for tightening the tourniquet 110 on the appendage. The turnkey 116 folds down for compact storage and flips up for rotation in order to tighten or loosen the tourniquet 110. The turnkey 116 can have a half-moon or semicircular shape, or any other shape that allows the user to easily grasp and rotate the turnkey. Further, the turnkey 116 can include a ribbed or textured surface to prevent the user's fingers from slipping off of the turnkey during use.

**[0036]** Figure 6 illustrates a side view of the C-clip 102 according to the second embodiment of the present invention. The mechanical advantage power system 108 includes the platen 124, release button 130 and winch 142, which are shown mounted onto the C-clip 102. The winch 142 and release button 130 are disposed in a housing 140a formed integrally with the C-clip at the front end. The housing 140a has a housing cover 140b.

**[0037]** An exemplary view of the interior of the housing 140a including components of the power system 108 is shown in Figure 7. The power system 108 within the housing 140a includes a ratchet arrangement comprising the winch 142 and pawl 146. The winch 142 serves to tighten the overall tourniquet on the appendage. The winch prevents over-winding, cord tangling and breakage that can occur with a tightening pulley system. The winch 142 includes a plurality of angled teeth that engage the pawl 146, which rests tangentially over the teeth. The pawl 146 permits rotation of the winch 142 in one direction only. Thus, when the turnkey 116 is rotated, the winch 142 rotates in a predetermined direction allowing the pawl 146 to slide over the teeth. The pawl 146 catches the teeth of the winch 142 if the winch attempts to rotate in the reverse direction.

**[0038]** In order to loosen the cord 128 in the power system 108, and thereby reduce the pressure on the appendage, the user can press or slide the release button 130, which removes the pawl 146 from engagement with the teeth of the winch 142. Thus, when the winch rotates in the reverse direction, the pawl 146 does not catch the winch teeth. Figure 11 illustrates the button as extending from the housing 140a, 140b indicating that the pawl 146 is engaged with the winch 142 to provide the mechanical advantage for tightening the tourniquet.

**[0039]** Figures 8 and 9 illustrate components of the power system 108 along a rear end portion of the C-clip 102. These components include an integrated, graduated track 134 formed on an outer surface of the C-clip 102 to allow a platen 124 mounted on the track 134 at a rear surface of the C-clip 102, to slide thereon. The platen 124 can be formed from any polymeric material including but not limited to nylon and acetal. The platen 124 includes a cross bar 132, as seen in Figure 9, for mounting the strap 112 to the rear end portion of the C-clip 102, and a plurality of apertures 126 through which a pair of interwoven or braided cords 128, tied together, are threaded. The cords 128 of the present invention are low in friction and can be a polyester blend, having a high strength-to-weight diameter ratio. The cord 128 is threaded from the platen 124 to a pair of bosses mounted on the C-clip adjacent to the housing 140a, 140b. The bosses serve to mount the housing cover 140b onto the housing 140a. The cord 128 is routed in a serpentine manner between the platen 124, bosses and winch 142 in the housing. The cord 128 enters the housing through an opening 144 and is wrapped around the body of the winch 142 when the winch is rotated. The housing cover 140b prevents the cord 128 from migrating or sliding off of the winch 142.

**[0040]** When disposed on the C-clip 102, the shroud 114 is elastically fixed at one end to a groove 152 in the strap guide and at the other end in a groove 154 between the housing 140a, 140b and the hook 100.

**[0041]** To close the tourniquet 110, the strap 112, is pulled around the C-clip 102 through the strap guide 150 to the hook 100, which is disposed on the front end of the C-clip 102. The locking member 120 is attached to the end of the strap 112 and is operatively connected to the hook 100. The strap 112 tightens the entire mechanical advantage tourniquet 110 onto and around the appendage. The strap 112 can be approximately 2,54 to 6,35 cm (1 to 2-1/2 inches) wide, and 76,2 cm (30 inches) or more in length so that the tourniquet is long enough use on all bodily appendages of different sized individuals.

**[0042]** By fastening the locking member 120 with the hook 100, the ends of the C-clip 102 are joined, closing the mechanical advantage tourniquet. The locking member 120 can include any well-known or currently sold ladder-style buckle such as that used for backpacks. Thus, the locking member 120 allows the strap to be adjusted on the appendage without having to unhook the strap

112 from the hook 100. The locking member 120 serves as locking means for locking the strap in place on the appendage.

**[0043]** The release button 130 includes a push-in detent molded into the shroud 114, which has a fail-safe return to the original position. The release button 130 can be positioned to minimally protrude from the side of the housing 140a so as to reduce accidental release of the winch 142

**[0044]** Figure 10 illustrates an exemplary top view of the housing cover 140b and release button 130 according to a second embodiment of the present invention. The release button 130 is illustrated as protruding from the housing, indicating that the pawl is engaged with the winch 142.

**[0045]** Figure 11 illustrates the button 130 as depressed or slid in the direction of the platen, indicating that the pawl has been released from the winch 142 so that the tourniquet can be loosened.

**[0046]** Figure 12 illustrates another exemplary view of the pawl 146 engaged with the winch 142, while Figure 13 illustrates a further exemplary view of the pawl 146 released from the winch 142.

**[0047]** An exemplary method of restricting the flow of blood through a body part may include:

placing the C-clip 102 and the elongated strap 112 around the appendage; engaging the locking member 120 device with the first end or hook 100 of the C-clip 102; pulling the strap 112 in a direction tangent to the surface of the C-clip 102, until the strap is secured tightly to the body part; raising the turnkey from a folded or horizontal position to a vertical position so that it is perpendicular to the plane of the shroud and C-clip; turning the turnkey in a predetermined direction until the turnkey and thus the winch 142 can no longer be turned indicating that maximum pressure is being applied to the appendage; and folding the turnkey to a horizontal position.

**[0048]** The exemplary method for changing or releasing the pressure on the appendage may include pressing the release button to release the pawl 146 from engagement with the winch 142; turning the turnkey 116 in the opposite direction; and loosening the strap 112 and locking member 120 while the locking member is engaged with the hook 100 or loosening the strap 112 upon removing the locking member 120 from hook 100 to release pressure on the appendage. Pulling an intermediate portion of the strap in a direction opposite to a tightening direction further loosens the tourniquet from the appendage.

**[0049]** The tourniquet 10, 110 is weather resistant in that the neoprene bellows or shroud is designed to prevent foreign substances or debris from entering the power system. The neoprene bellows and shroud also slow the amount of water that can enter the power system and thereby allow the tourniquet to resist sinking in water.

The tourniquet can be any color suitable for use. For example, the tourniquet can be colored in a camouflage pattern such as for example, beige and brown to match military uniforms used in a desert environment; or black, olive and green to match military uniforms used in a jungle or forested environment. The tourniquet can also have, at least in part, colors suitable for Emergency Medical Technician or Emergency Medical Services use such as, for example, fluorescent orange or fluorescent yellow. In addition, the overall tourniquet or any one of the components can be coated with a luminescent paint to facilitate night vision.

**[0050]** Example embodiments of the present invention have now been described in accordance with the above advantages. It will be appreciated that these examples are merely illustrative of the invention. Many variations and modifications will be apparent to those skilled in the art, without departing from the scope of the present disclosure as defined by the appended claim.

**Claims**

1. A pressure control apparatus (10, 110) for restricting a flow of blood through or from a body part, the apparatus comprising:

at least one arcuate member (2, 102) for attaching to the body part, the at least one arcuate member comprising a first end (4, 104) and an opposite second end (6, 106);  
 a primary tightening device mounted on the at least one arcuate member for adjusting a pressure of the apparatus on the body part, wherein the primary tightening device comprises a mechanical advantage power system (8, 108) ;  
 a secondary tightening device disposed on at least a portion of the arcuate member for circumferentially tightening the apparatus on the body part; and  
 a locking device (20, 120) for closing the apparatus around the body part, the locking device (20, 120) being operatively connected to the at least one arcuate member (2, 102) **characterized in that:**

the mechanical advantage power system (8, 108) comprises a winding cord (28, 128) and a cord retracting device (42, 142).

2. The pressure control apparatus according to claim 1, wherein the mechanical advantage power system (8, 108) comprises a system selected from the group consisting of a pulley, eyelet, post system, needle bobbin, gears, levers, wheels, and cams.

3. The pressure control apparatus according to claim 1, wherein the mechanical advantage power system

(8, 108) further comprises a rotatable and pivotable turnkey for rotating the cord-retracting device (42, 142).

4. The pressure control apparatus according to claim 3, wherein the turnkey (16, 116) comprises a textured handle.

5. The pressure control apparatus according to claim 1, wherein the secondary tightening device comprises an elongated strap (12, 112) circumscribing the apparatus.

6. The pressure control apparatus according to claim 5, wherein the elongated strap (12, 112) comprises a nylon material.

7. The pressure control apparatus according to claim 6, wherein the elongated strap (12, 112) comprises a gripping portion at one end for securely grasping the elongated strap.

8. The pressure control apparatus according to claim 1, wherein the locking device (20, 120) comprises a locking lever (22, 122) that pivots on the second end of the at least one arcuate member (2, 102) along a circumferential direction of the apparatus to secure the secondary tightening device.

9. The pressure control apparatus according to claim 8, wherein the locking lever (22, 122) is snap fit onto the second end of the at least one arcuate member.

10. The pressure control apparatus according to claim 1, wherein the at least one arcuate member (2, 102) comprises a flexible polymeric material.

11. The pressure control apparatus according to claim 10, wherein the flexible polymeric material comprises a material selected from a group consisting of acetal, nylon, polypropylene, and polyethylene.

12. The pressure control apparatus according to claim 1, further comprising a cover (14, 114) enclosing a portion of the primary tightening device.

13. The pressure control apparatus according to claim 12, wherein the cover (14, 114) comprises expandable and contractible bellows.

14. The pressure control apparatus according to claim 12, wherein the cover (14, 114) comprises a flexible polymeric material.

15. The pressure control apparatus according to claim 1, further comprising luminescent markings for identification in a darkened environment.

16. The pressure control apparatus according to claim 1, wherein the apparatus is weather resistant.
17. The pressure control apparatus according to claim 1, wherein the apparatus resists sinking in water. 5
18. The pressure control apparatus according to claim 1, wherein the at least one arcuate member comprises a single molded C-clip (102). 10
19. The pressure control apparatus according to claim 18, wherein the C-clip (102) comprises a fastening element integral with respect thereto, the locking device being operatively connected to the fastening element. 15
20. The pressure control apparatus according to claim 19, wherein the fastening element comprises a hook (100). 20
21. The pressure control apparatus according to claim 20, wherein the locking device comprises a buckle.
22. The pressure control apparatus according to claim 1, further comprising a housing (1409) of the primary tightening device, the housing being integral with the at least one arcuate member (2, 102). 25
23. The pressure control apparatus according to claim 1, wherein the mechanical advantage power system comprises a release button (130). 30
24. The pressure control apparatus according to claim 1, wherein the at least one arcuate member (2, 102) comprises a plurality of protrusions (136) on an interior surface for gripping the body part. 35
25. The pressure control apparatus according to claim 24, wherein the protrusions form a crenellated surface. 40
26. The pressure control apparatus according to claim 1, wherein the mechanical advantage power system comprises a plurality of cords (28, 128) linking a platen member and the cord-retracting device is mounted on the at least one arcuate member for tightening the pressure on the body part. 45
27. The pressure control apparatus according to claim 1, wherein the apparatus comprises a tourniquet. 50

#### Patentansprüche

1. Drucksteuervorrichtung (10, 110) zum Begrenzen eines Blutflusses durch einen oder aus einem Körperteil, wobei die Vorrichtung umfasst: 55

mindestens ein bogenförmiges Element (2, 102) zum Befestigen an dem Körperteil, wobei das mindestens eine bogenförmige Element ein erstes Ende (4, 104) und ein entgegengesetztes zweites Ende (6, 106) umfasst; eine primäre Spanneinheit, die an dem mindestens einen bogenförmigen Element angebracht ist, um einen Druck der Vorrichtung an dem Körperteil einzustellen, wobei die primäre Spanneinheit ein mechanisches Kraftverstärkungssystem (8, 108) umfasst; eine sekundäre Spanneinheit, die an mindestens einem Abschnitt des bogenförmigen Elements angeordnet ist, um die Vorrichtung am Körperteil in Umfangsrichtung festzuziehen; und eine Verriegelungseinheit (20, 120) zum Verschließen der Vorrichtung um den Körperteil herum, wobei die Verriegelungseinheit (20, 120) mit dem mindestens einen bogenförmigen Element (2, 102) in Wirkverbindung steht, **dadurch gekennzeichnet, dass:**

- das mechanische Kraftverstärkungssystem (8, 108) eine Wicklungsschnur (28, 128) und eine Schnuraufrolleinheit (42, 142) umfasst.
2. Drucksteuervorrichtung nach Anspruch 1, wobei das mechanische Kraftverstärkungssystem (8, 108) ein System umfasst, das aus der Gruppe ausgewählt ist, die aus einer Riemenscheibe, einer Öse, einem Stiftsystem, einer Nadelspule, Zahnrädern, Hebeln, Rädern und Nocken besteht.
3. Drucksteuervorrichtung nach Anspruch 1, wobei das mechanische Kraftverstärkungssystem (8, 108) ferner einen drehbaren und schwenkbaren Drehschlüssel zum Drehen der Schnuraufrolleinheit (42, 142) umfasst.
4. Drucksteuervorrichtung nach Anspruch 3, wobei der Drehschlüssel (16, 116) einen strukturierten Griff umfasst.
5. Drucksteuervorrichtung nach Anspruch 1, wobei die sekundäre Spanneinheit ein längliches Band (12, 112) umfasst, das die Vorrichtung umgibt.
6. Drucksteuervorrichtung nach Anspruch 5, wobei das längliche Band (12, 112) ein Nylonmaterial umfasst.
7. Drucksteuervorrichtung nach Anspruch 6, wobei das längliche Band (12, 112) an einem Ende einen Greifabschnitt zum sicheren Greifen des länglichen Bandes umfasst.
8. Drucksteuervorrichtung nach Anspruch 1, wobei die



- Verriegelungseinheit (20, 120) einen Verriegelungshebel (22, 122) umfasst, der an dem zweiten Ende des mindestens einen bogenförmigen Elements (2, 102) entlang einer Umfangsrichtung der Vorrichtung schwenkt, um die sekundäre Spanneinheit zu befestigen. 5
9. Drucksteuervorrichtung nach Anspruch 8, wobei der Verriegelungshebel (22, 122) auf das zweite Ende des mindestens einen bogenförmigen Elements einschnappt. 10
10. Drucksteuervorrichtung nach Anspruch 1, wobei das mindestens eine bogenförmige Element (2, 102) ein flexibles Polymermaterial umfasst. 15
11. Drucksteuervorrichtung nach Anspruch 10, wobei das flexible Polymermaterial ein Material umfasst, das aus einer Gruppe ausgewählt ist, die aus Acetal, Nylon, Polypropylen und Polyethylen besteht. 20
12. Drucksteuervorrichtung nach Anspruch 1, ferner umfassend eine Abdeckung (14, 114), die einen Abschnitt der primären Spanneinheit umschließt. 25
13. Drucksteuervorrichtung nach Anspruch 12, wobei die Abdeckung (14, 114) auseinander- und zusammenziehbare Balgen aufweist.
14. Drucksteuervorrichtung nach Anspruch 12, wobei die Abdeckung (14, 114) ein flexibles Polymermaterial umfasst. 30
15. Drucksteuervorrichtung nach Anspruch 1, ferner umfassend lumineszierende Markierungen zur Erkennung in einer abgedunkelten Umgebung. 35
16. Drucksteuervorrichtung nach Anspruch 1, wobei die Vorrichtung wetterbeständig ist. 40
17. Drucksteuervorrichtung nach Anspruch 1, wobei die Vorrichtung einem Einsinken in Wasser standhält.
18. Drucksteuervorrichtung nach Anspruch 1, wobei das mindestens eine bogenförmige Element eine einzelne geformte C-Klammer (102) umfasst. 45
19. Drucksteuervorrichtung nach Anspruch 18, wobei die C-Klammer (102) ein damit einstückiges Befestigungselement umfasst, wobei die Verriegelungseinheit mit dem Befestigungselement in Wirkverbindung steht. 50
20. Drucksteuervorrichtung nach Anspruch 19, wobei das Befestigungselement einen Haken (100) umfasst. 55
21. Drucksteuervorrichtung nach Anspruch 20, wobei die Verriegelungseinheit eine Schnalle umfasst.
22. Drucksteuervorrichtung nach Anspruch 1, ferner umfassend ein Gehäuse (1409) der primären Spanneinheit, wobei das Gehäuse mit dem mindestens einen bogenförmigen Element (2, 102) einstückig ist.
23. Drucksteuervorrichtung nach Anspruch 1, wobei das mechanische Kraftverstärkungssystem einen Entriegelungsknopf (130) umfasst.
24. Drucksteuervorrichtung nach Anspruch 1, wobei das mindestens eine bogenförmige Element (2, 102) eine Vielzahl von Vorsprüngen (136) auf einer Innenfläche zum Greifen des Körperteils aufweist.
25. Drucksteuervorrichtung nach Anspruch 24, wobei die Vorsprünge eine gerippte Oberfläche bilden.
26. Drucksteuervorrichtung nach Anspruch 1, wobei das mechanische Kraftverstärkungssystem eine Vielzahl von Schnüren (28, 128) umfasst, die mit einem Plattenelement verbunden sind, und die Schnuraufrollvorrichtung an dem mindestens einen bogenförmigen Element montiert ist, um den Druck auf den Körperteil zu erhöhen.
27. Drucksteuervorrichtung nach Anspruch 1, wobei die Vorrichtung ein Tourniquet umfasst.

#### Revendications

1. Appareil de régulation de pression (10, 110) permettant de limiter un écoulement sanguin à travers ou depuis une partie du corps, l'appareil comprenant :
- au moins un élément arqué (2, 102) pour une fixation à la partie du corps, l'au moins un élément arqué comprenant une première extrémité (4, 104) et une seconde extrémité (6, 106) opposée ;
- un dispositif de serrage principal monté sur l'au moins un élément arqué pour ajuster une pression de l'appareil sur la partie du corps, le dispositif de serrage principal comprenant un système générateur d'effet mécanique (8, 108) ;
- un dispositif de serrage secondaire disposé sur au moins une partie de l'élément arqué pour serrer circonférentiellement l'appareil sur la partie du corps ; et
- un dispositif de verrouillage (20, 120) permettant de fermer l'appareil autour de la partie du corps, le dispositif de verrouillage (20, 120) étant relié fonctionnellement à l'au moins un élément arqué (2, 102), **caractérisé en ce que** :
- le système générateur d'effet mécanique

- (8, 108) comprend un cordon d'enroulement (28, 128) et un dispositif (42, 142) de rétraction de cordon.
2. Appareil de régulation de pression selon la revendication 1, dans lequel le système générateur d'effet mécanique (8, 108) comprend un système sélectionné dans le groupe constitué par une poulie, un oeillet, un système de pivot, une canette d'aiguille, des pignons, des leviers, des roues et des cames. 5
  3. Appareil de régulation de pression selon la revendication 1, dans lequel le système générateur d'effet mécanique (8, 108) comprend en outre une clé rotative et pivotante permettant de faire tourner le dispositif (42, 142) de rétraction de cordon. 10
  4. Appareil de régulation de pression selon la revendication 3, dans lequel la clé (16, 116) comprend une poignée texturée. 15
  5. Appareil de régulation de pression selon la revendication 1, dans lequel le dispositif de serrage secondaire comprend une sangle allongée (12, 112) entourant l'appareil. 20
  6. Appareil de régulation de pression selon la revendication 5, dans lequel la sangle allongée (12, 112) comprend un matériau en nylon. 25
  7. Appareil de régulation de pression selon la revendication 6, dans lequel la sangle allongée (12, 112) comprend une partie de préhension au niveau d'une extrémité pour saisir fermement la sangle allongée. 30
  8. Appareil de régulation de pression selon la revendication 1, dans lequel le dispositif de verrouillage (20, 120) comprend un levier de verrouillage (22, 122) qui pivote sur la seconde extrémité de l'au moins un élément arqué (2, 102) le long d'une direction circconférentielle de l'appareil afin d'assujettir le dispositif de serrage secondaire. 35
  9. Appareil de régulation de pression selon la revendication 8, dans lequel le levier de verrouillage (22, 122) est encliqueté sur la seconde extrémité de l'au moins un élément arqué. 40
  10. Appareil de régulation de pression selon la revendication 1, dans lequel l'au moins un élément arqué (2, 102) comprend un matériau polymère flexible. 45
  11. Appareil de régulation de pression selon la revendication 10, dans lequel le matériau polymère flexible comprend un matériau sélectionné dans le groupe consistant en l'acétal, le nylon, le polypropylène et le polyéthylène. 50
  12. Appareil de régulation de pression selon la revendication 1, comprenant en outre un couvercle (14, 114) renfermant une partie du dispositif de serrage principal. 55
  13. Appareil de régulation de pression selon la revendication 12, dans lequel le couvercle (14, 114) comprend des soufflets pouvant se dilater et se contracter. 60
  14. Appareil de régulation de pression selon la revendication 12, dans lequel le couvercle (14, 114) comprend un matériau polymère flexible. 65
  15. Appareil de régulation de pression selon la revendication 1, comprenant en outre des repères lumineux pour une identification dans un environnement sombre. 70
  16. Appareil de régulation de pression selon la revendication 1, l'appareil résistant aux intempéries. 75
  17. Appareil de régulation de pression selon la revendication 1, l'appareil résistant à une immersion dans l'eau. 80
  18. Appareil de régulation de pression selon la revendication 1, dans lequel l'au moins un élément arqué comprend une pince en C moulée simple (102). 85
  19. Appareil de régulation de pression selon la revendication 18, dans lequel la pince en C (102) comprend un élément de fixation solidaire de celle-ci, le dispositif de verrouillage étant relié fonctionnellement à l'élément de fixation. 90
  20. Appareil de régulation de pression selon la revendication 19, dans lequel l'élément de fixation comprend un crochet (100). 95
  21. Appareil de régulation de pression selon la revendication 20, dans lequel le dispositif de verrouillage comprend une boucle. 100
  22. Appareil de régulation de pression selon la revendication 1, comprenant en outre un boîtier (1409) du dispositif de serrage principal, le boîtier étant solidaire de l'au moins un élément arqué (2, 102). 105
  23. Appareil de régulation de pression selon la revendication 1, dans lequel le système générateur d'effet mécanique comprend un bouton de libération (130). 110
  24. Appareil de régulation de pression selon la revendication 1, dans lequel l'au moins un élément arqué (2, 102) comprend une pluralité de saillies (136) sur une surface intérieure pour saisir la partie du corps. 115

25. Appareil de régulation de pression selon la revendication 24, dans lequel les saillies forment une surface crénelée.
26. Appareil de régulation de pression selon la revendication 1, dans lequel le système générateur d'effet mécanique comprend une pluralité de cordons (28, 128) reliant un élément formant platine et le dispositif de rétraction de cordon est monté sur l'au moins un élément arqué pour accentuer la pression sur la partie du corps. 5 10
27. Appareil de régulation de pression selon la revendication 1, l'appareil comprenant un garrot. 15

20

25

30

35

40

45

50

55

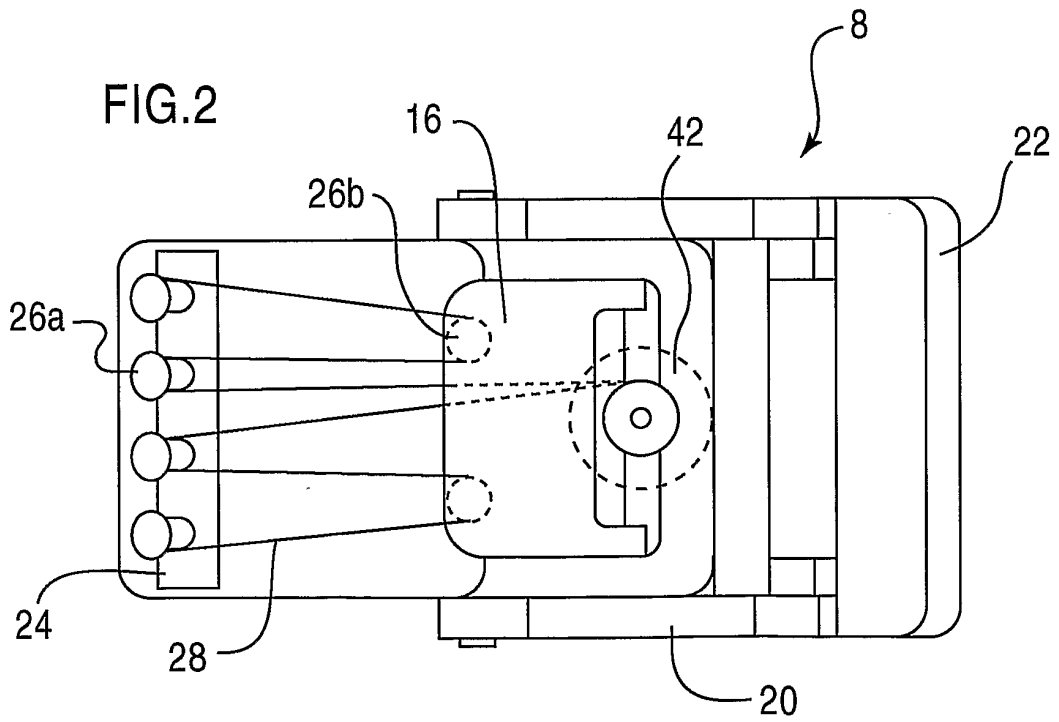
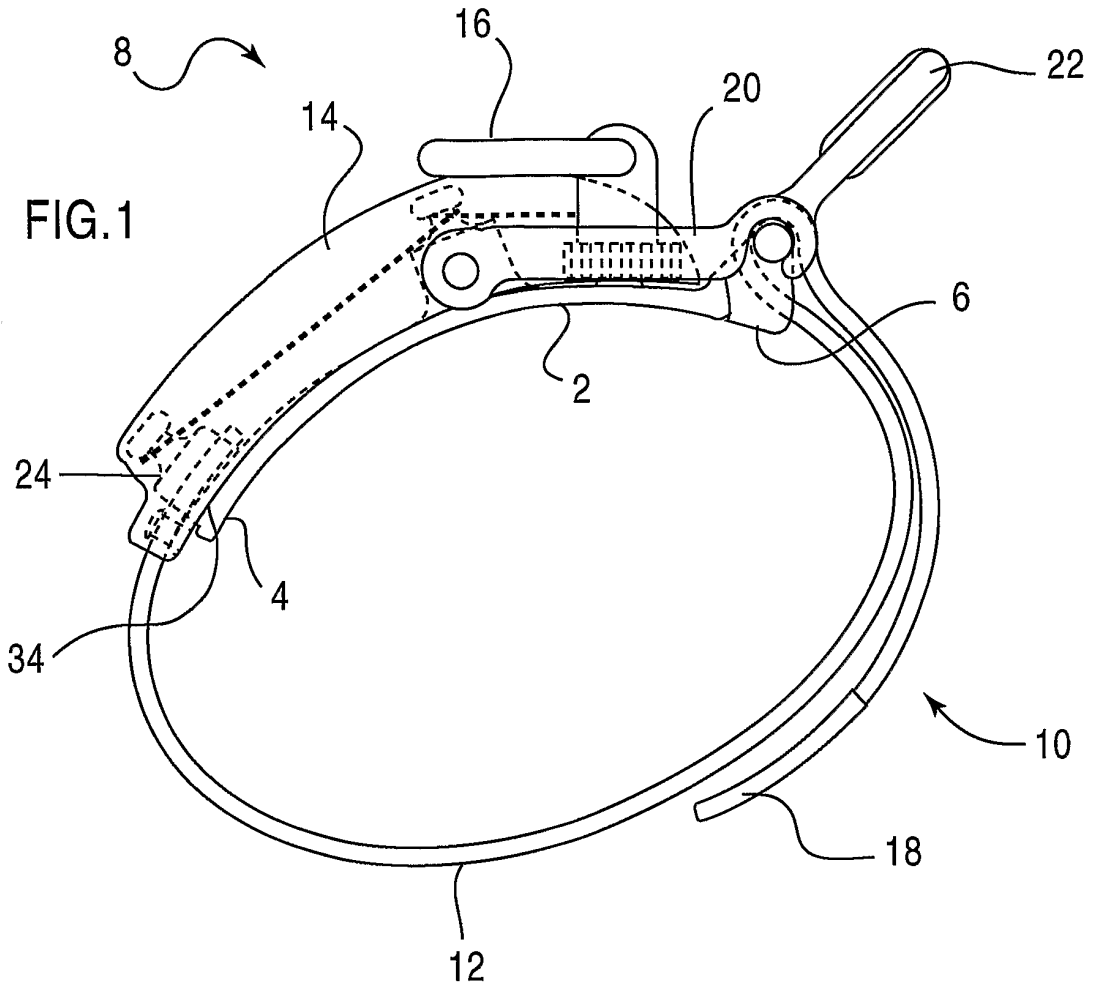
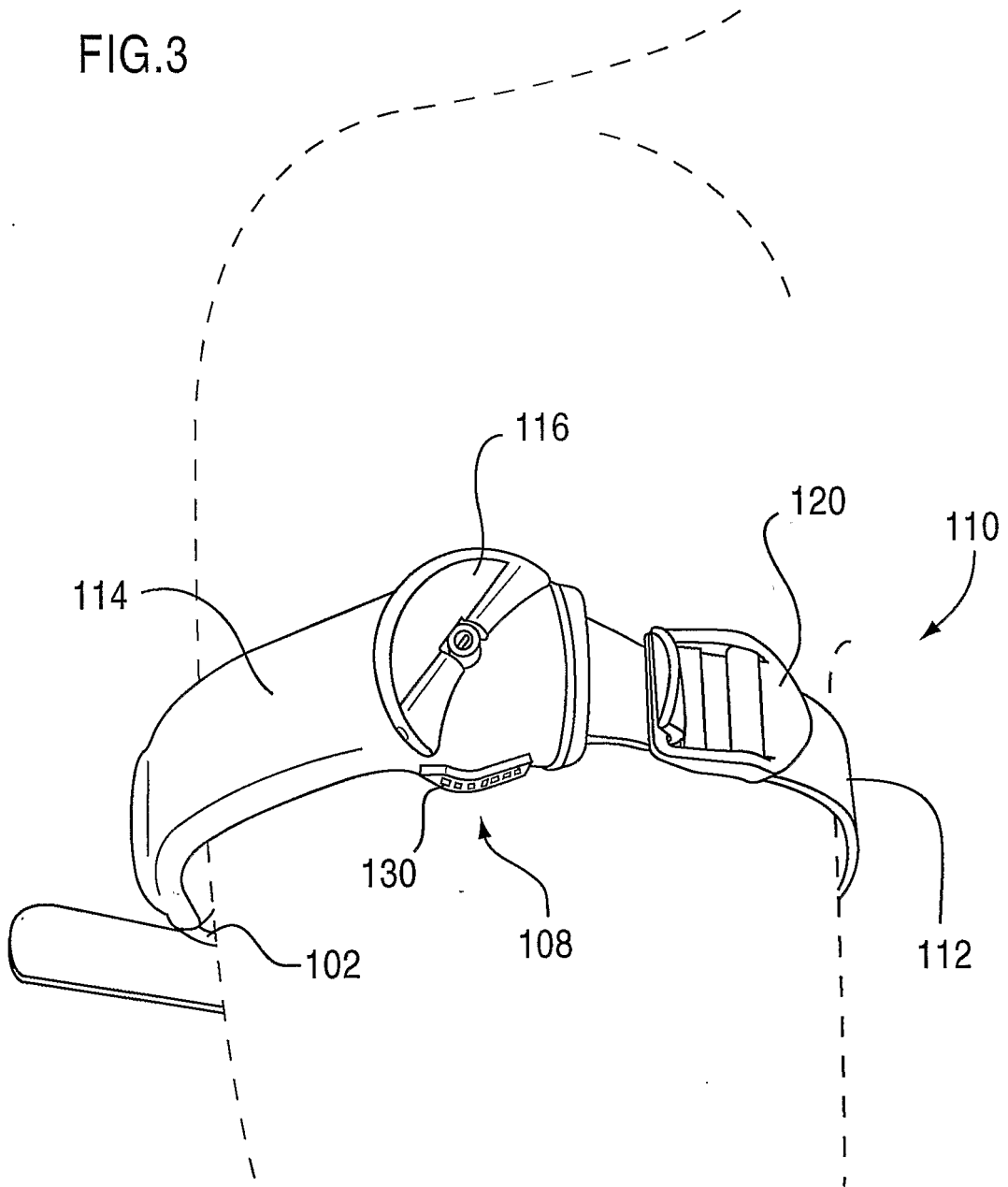

FIG.3



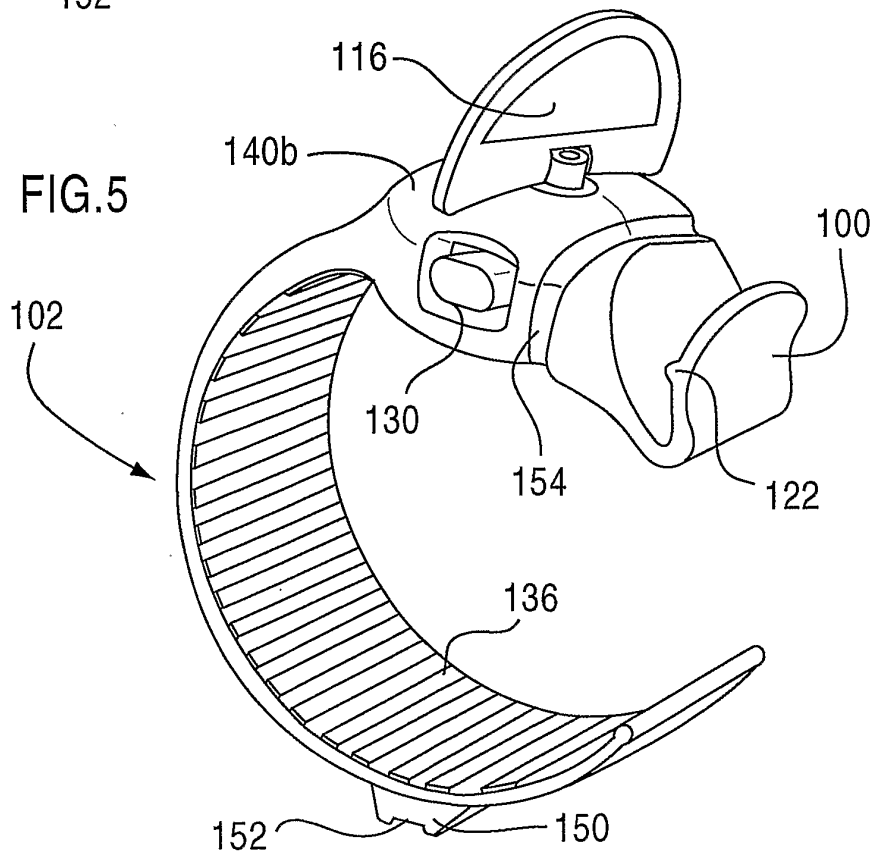
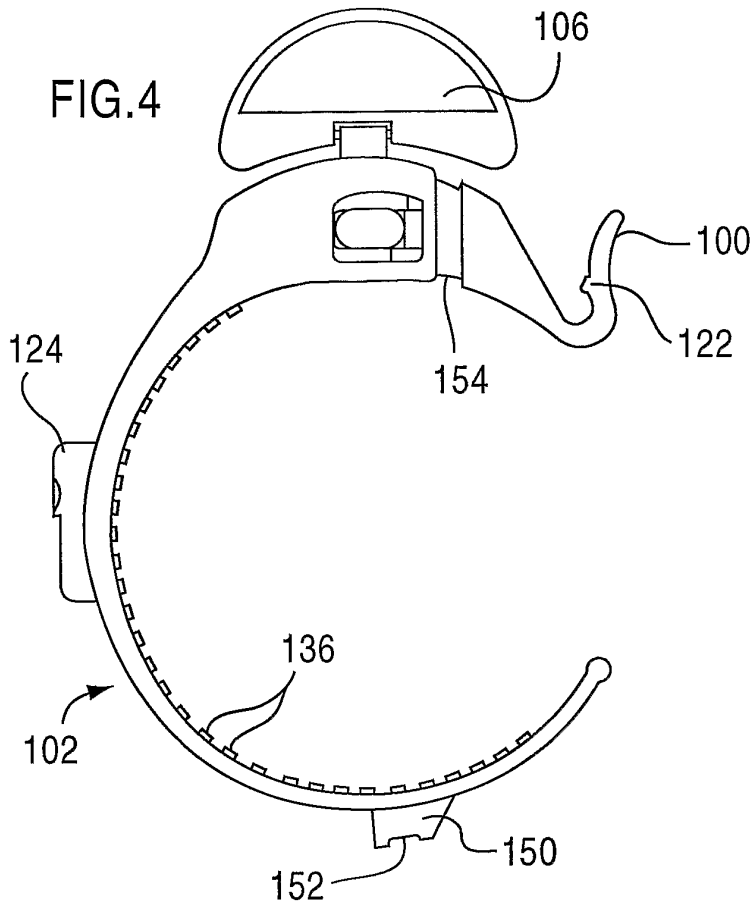

FIG.6

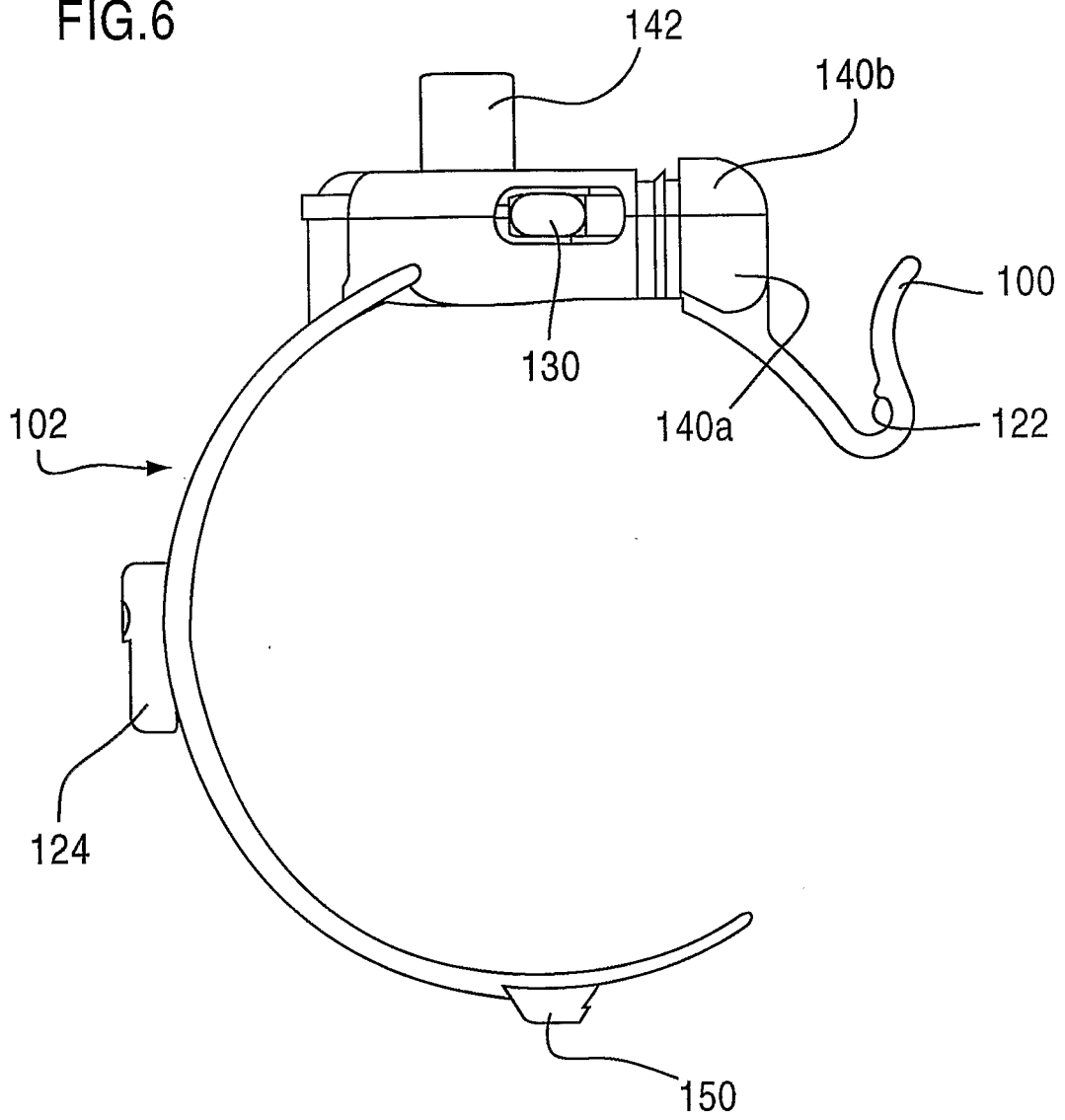

FIG.7

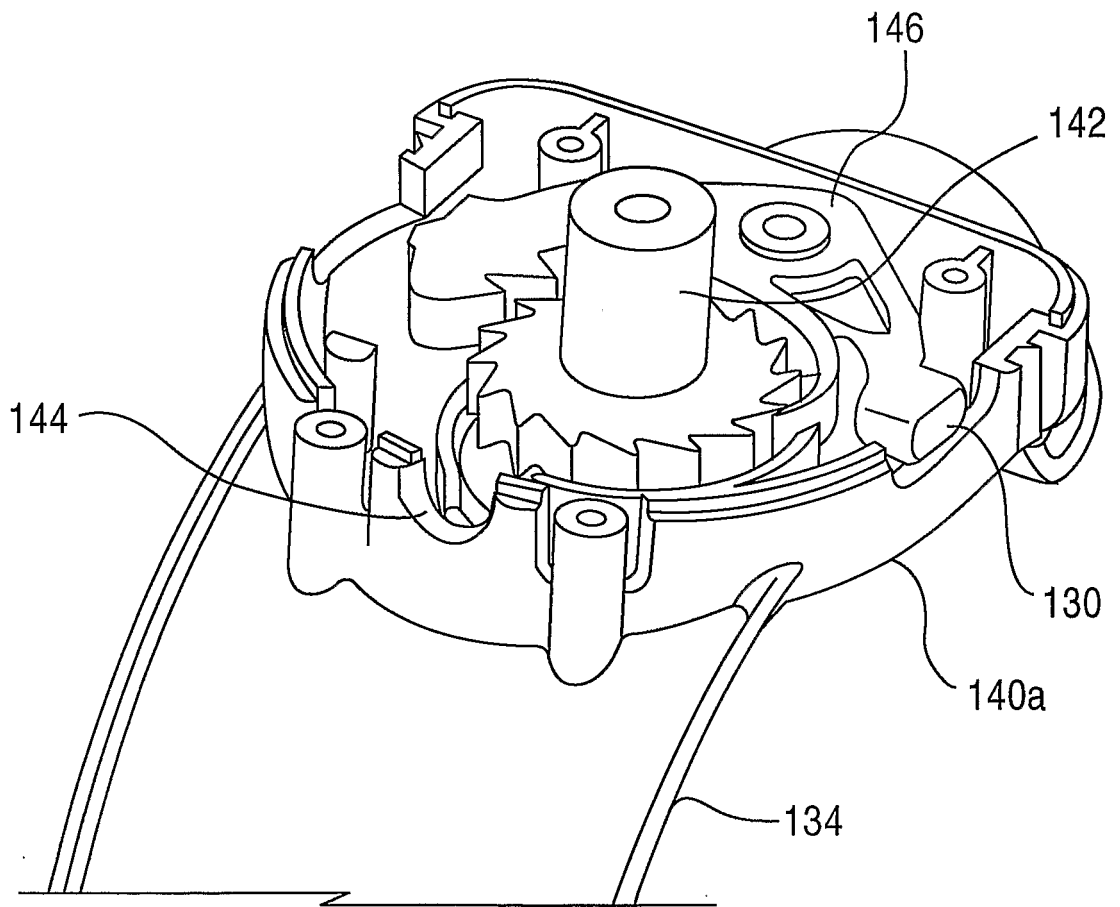



FIG.8

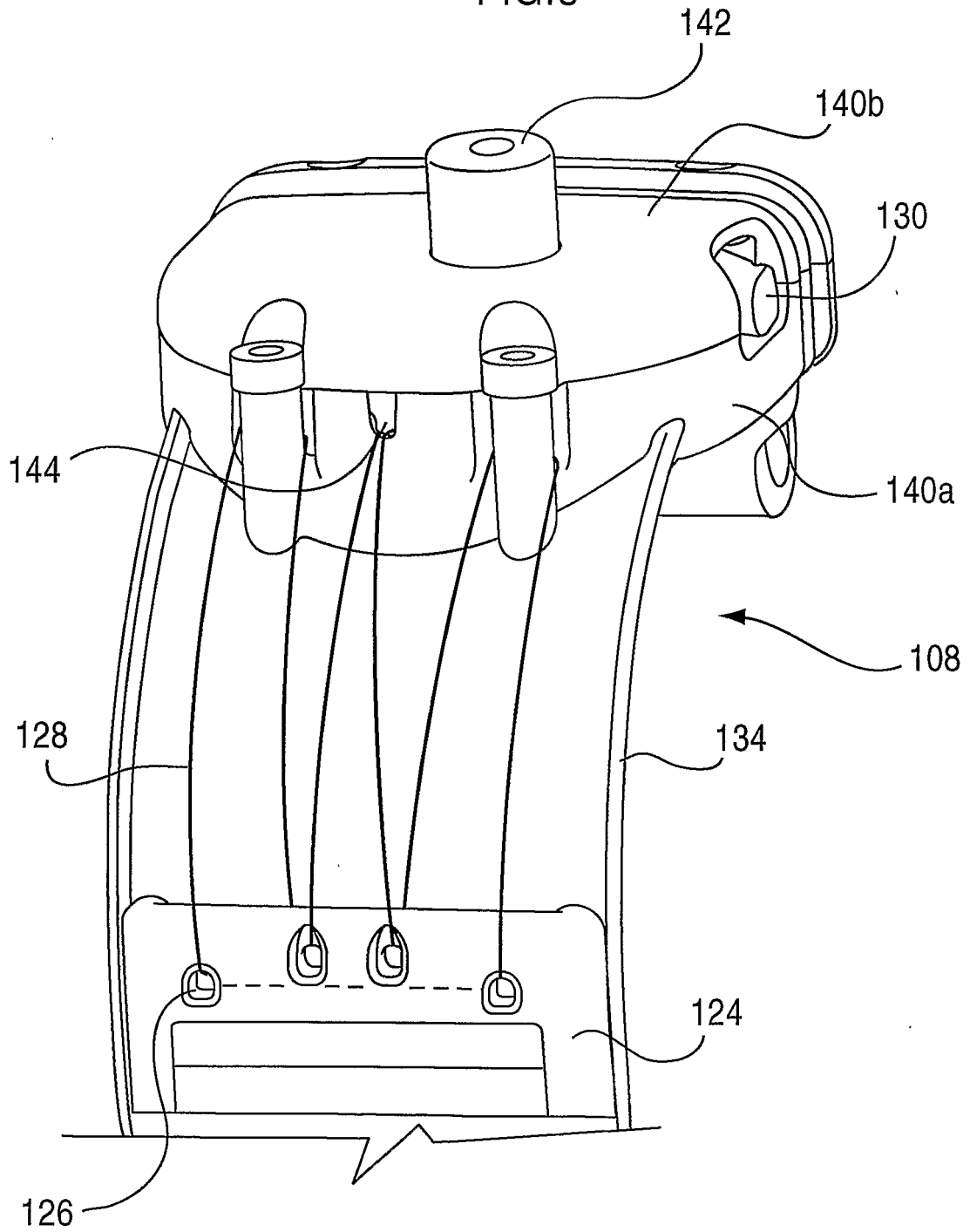

FIG.9

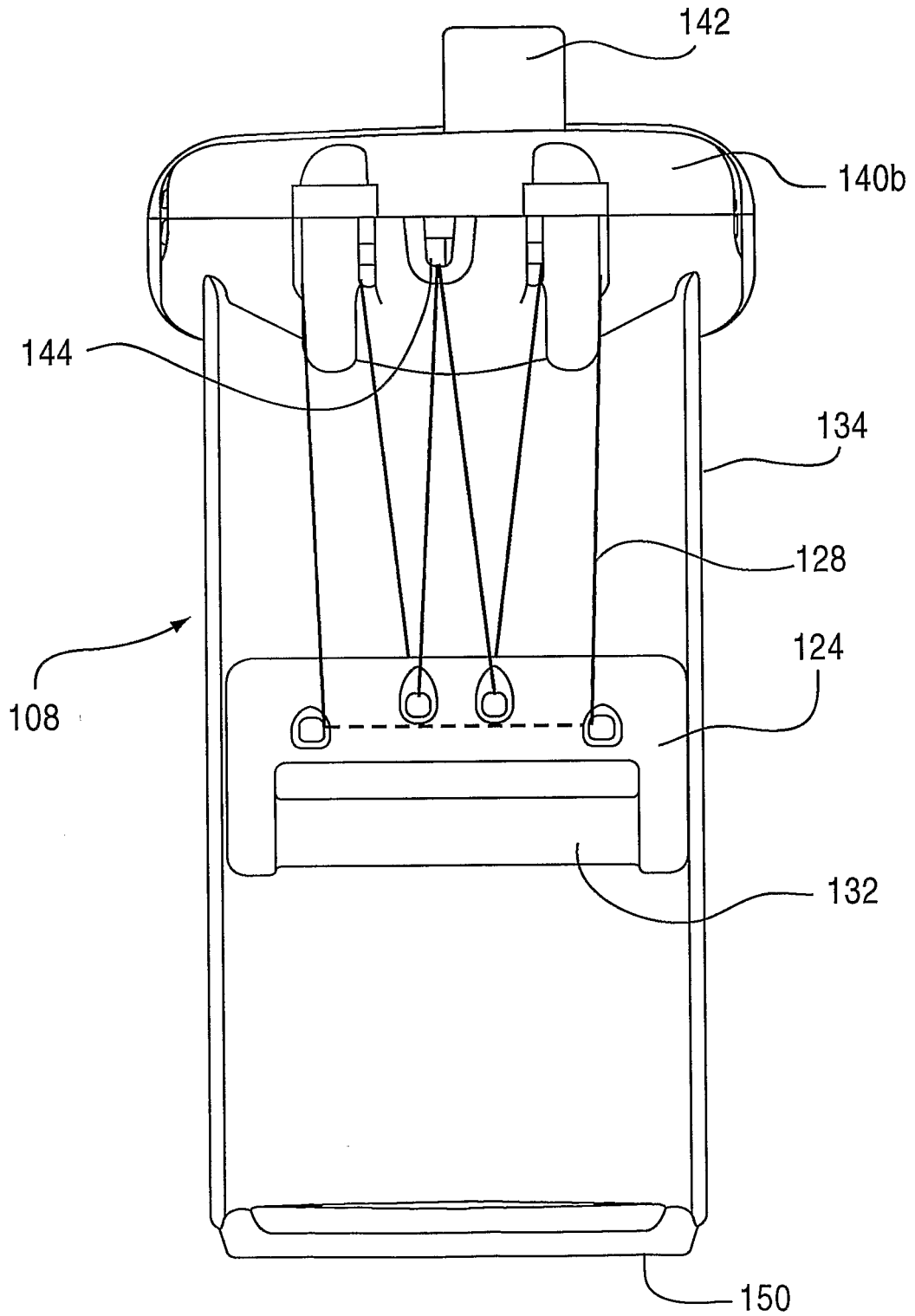

FIG.10

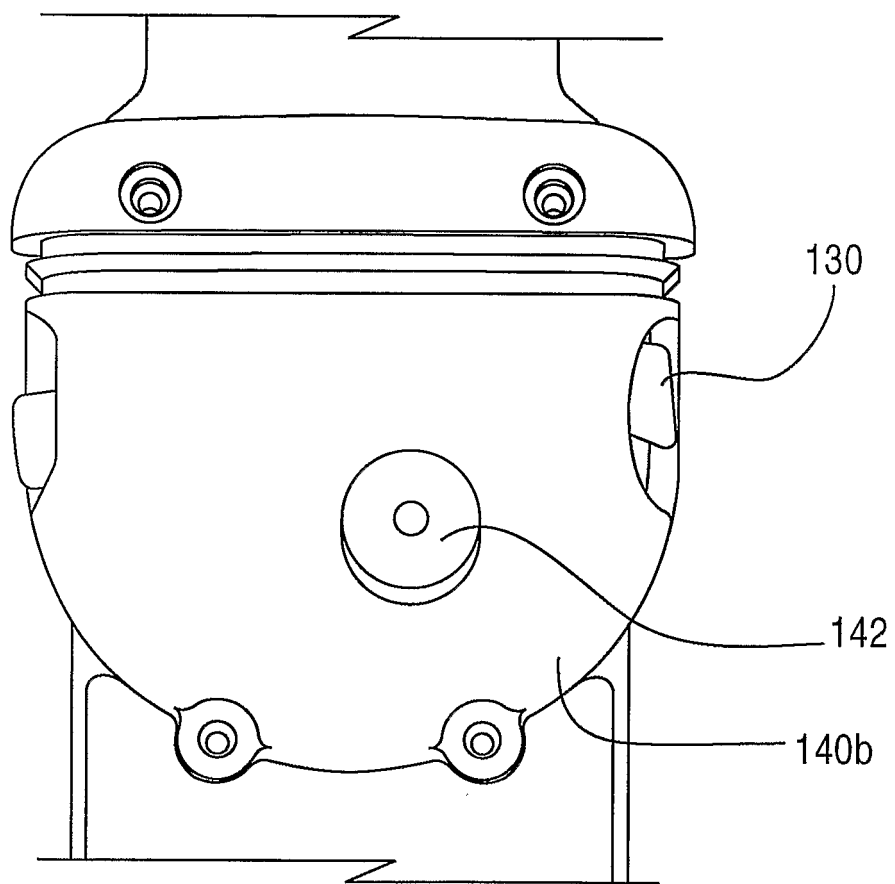

FIG.11

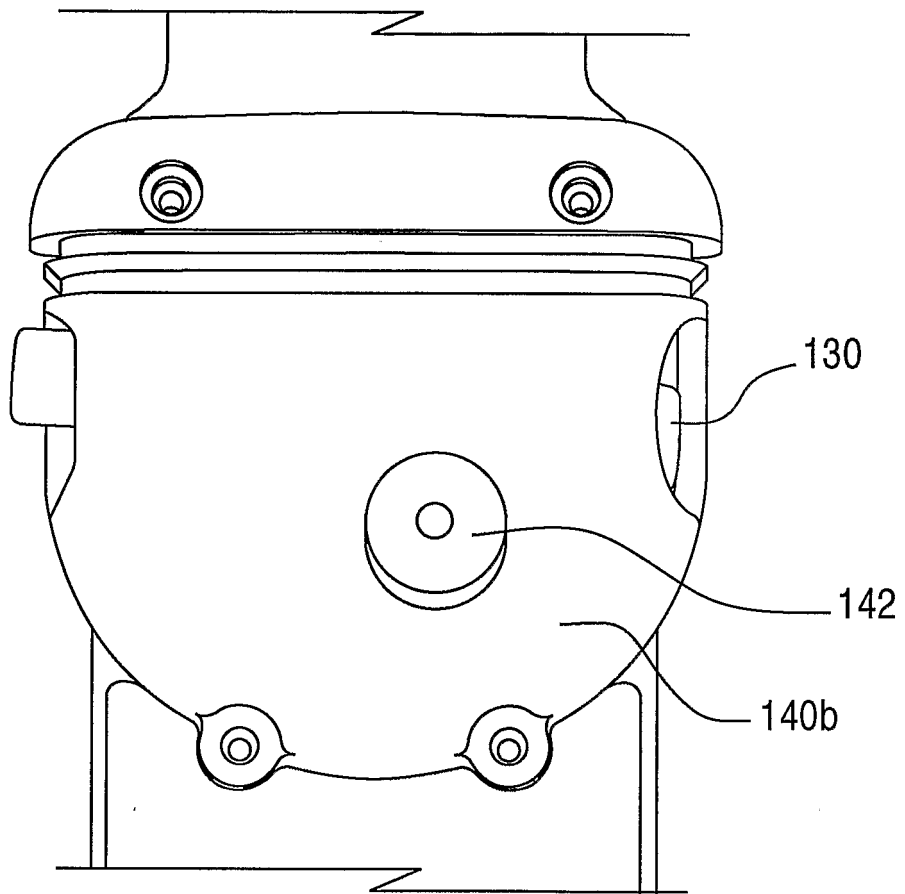

FIG.12

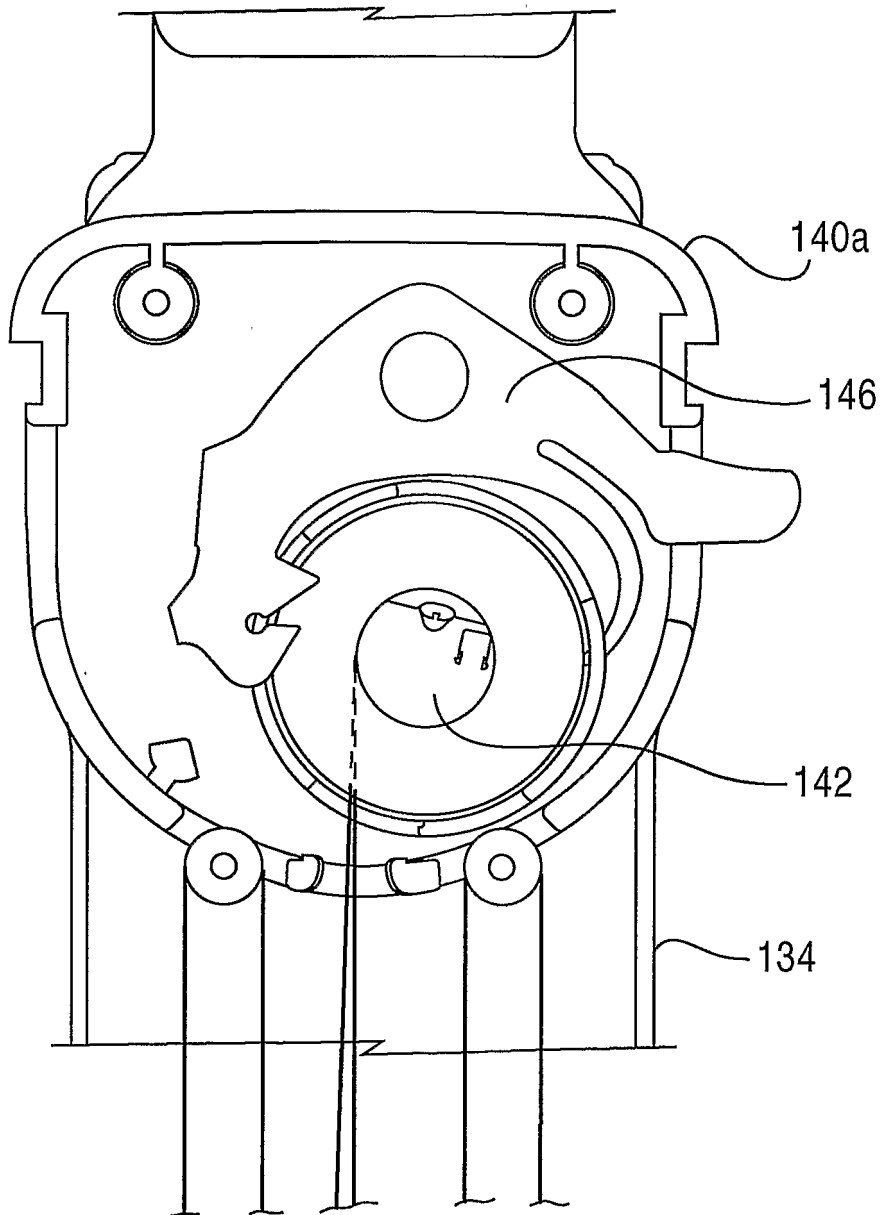
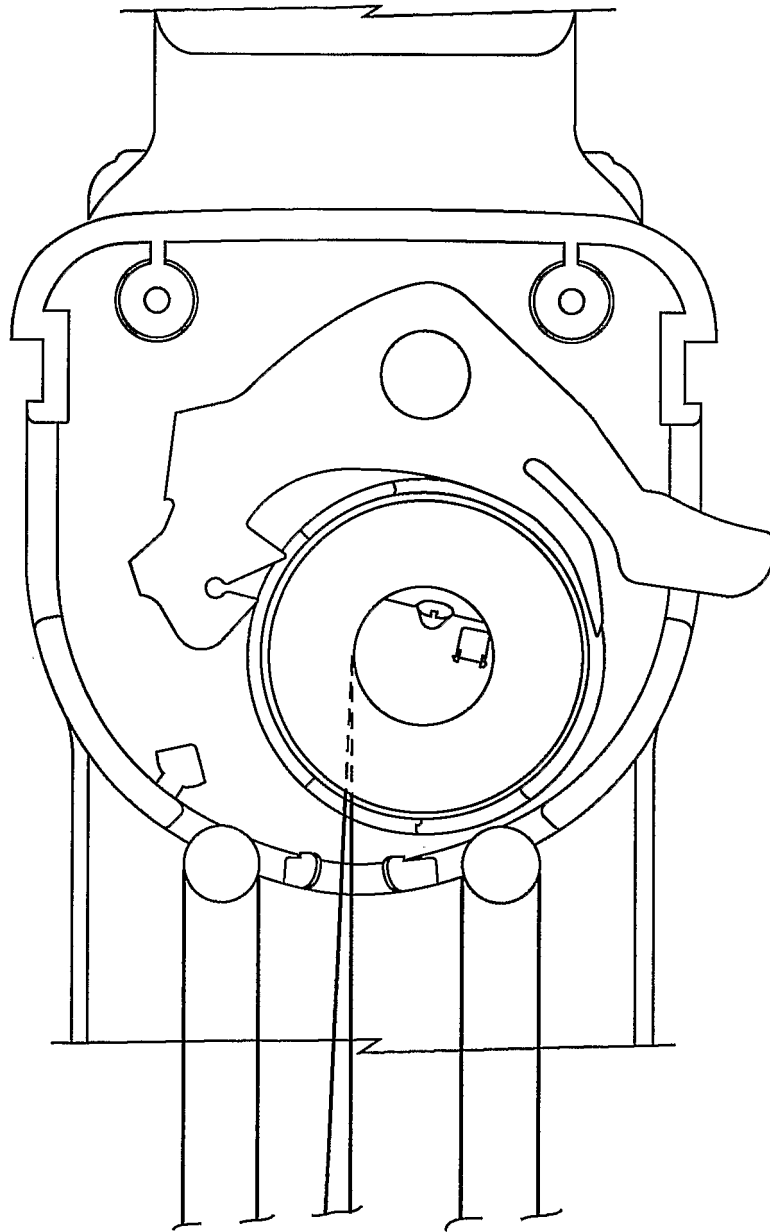

FIG.13



**REFERENCES CITED IN THE DESCRIPTION**

*This list of references cited by the applicant is for the reader's convenience only. It does not form part of the European patent document. Even though great care has been taken in compiling the references, errors or omissions cannot be excluded and the EPO disclaims all liability in this regard.*

**Patent documents cited in the description**

- DE 3133793 A1 [0005]
- US 4243039 A [0006]
- GB 2027149 A [0007]