



US00D815672S

(12) **United States Design Patent**  
**Shikama**

(10) **Patent No.:** **US D815,672 S**  
(45) **Date of Patent:** **\*\* Apr. 17, 2018**

(54) **CUTTING TOOL**

(71) Applicant: **TUNGALOY CORPORATION**,  
Iwaki-shi, Fukushima (JP)

(72) Inventor: **Hiroya Shikama**, Iwaki (JP)

(73) Assignee: **TUNGALOY CORPORATION**,  
Iwaki, Fukushima (JP)

(\*\*) Term: **15 Years**

(21) Appl. No.: **29/600,383**

(22) Filed: **Apr. 12, 2017**

(30) **Foreign Application Priority Data**

Jan. 26, 2017 (JP) ..... 2017-001313

(51) **LOC (11) Cl.** ..... **15-03**

(52) **U.S. Cl.**  
USPC ..... **D15/139**

(58) **Field of Classification Search**

USPC ..... D15/124-144; D8/70, 90, 98, 120  
CPC ..... B23C 2200/0411; B23C 2200/0416; B23C  
2200/0433; B23C 2200/164; B23C  
2200/361; B23C 2210/0457; B23C 5/006;  
B23C 2200/168; B23C 2210/163; B23C  
2226/125; B23C 5/10; B23C 2200/081;  
B23C 2200/087; B23C 2200/161; B23C  
2200/206; B23C 2210/02; B23C 2210/03;  
B23C 2210/166; B23C 2210/50; B23C  
2226/315; B23C 5/2208; B23C 5/2472;  
B23C 2200/0477; B23C 2200/0483;  
B23C 2200/083; B23C 2200/121; B23C  
2200/362; B23C 2210/0428; B23C  
2210/0435; B23C 2210/16; B23C  
2220/36; B23C 2220/44; B23C 2240/08;  
B23C 2250/12; B23C 2270/06; B23C  
5/2204; B23C 5/2213; B23C 5/2247;  
B23C 5/2427; B23C 2200/0422; B23C  
2200/08; B23C 2200/086; B23C  
2200/123

See application file for complete search history.

(56) **References Cited**

U.S. PATENT DOCUMENTS

D442,192 S *	5/2001	Strong	.....	D15/139
D519,532 S *	4/2006	Strand	.....	D15/139
D549,249 S *	8/2007	Omi	.....	D15/139
D609,257 S *	2/2010	Frejd	.....	D15/139
D620,034 S *	7/2010	Sjoo	.....	D15/139
D626,979 S *	11/2010	Anderson	.....	D15/139
D627,805 S *	11/2010	Dost	.....	D15/139
D678,925 S *	3/2013	Glimpel	.....	D15/139

(Continued)

*Primary Examiner* — Ian Simmons

*Assistant Examiner* — Khawaja Anwar

(74) *Attorney, Agent, or Firm* — Sughrue Mion, PLLC

(57) **CLAIM**

The ornamental design for a cutting tool, as shown and described.

**DESCRIPTION**

FIG. 1 is a first perspective view of a cutting tool showing my new design;  
FIG. 2 is a second perspective view;  
FIG. 3 is a front view;  
FIG. 4 is a rear view;  
FIG. 5 is a left side view;  
FIG. 6 is a right side view;  
FIG. 7 is a top plan view;  
FIG. 8 is a bottom view;  
FIG. 9 is a perspective enlarged view of a part shown in FIG. 1 indicated by 9; and,  
FIG. 10 is a perspective enlarged view of a part shown in FIG. 2 indicated by 10.

The broken lines shown in drawings represent portions of the cutting tool that form no part of the claimed design; The dash-dot-dot-dash lines represent the boundary of the claimed design and form no part of the claimed design.

**1 Claim, 7 Drawing Sheets**

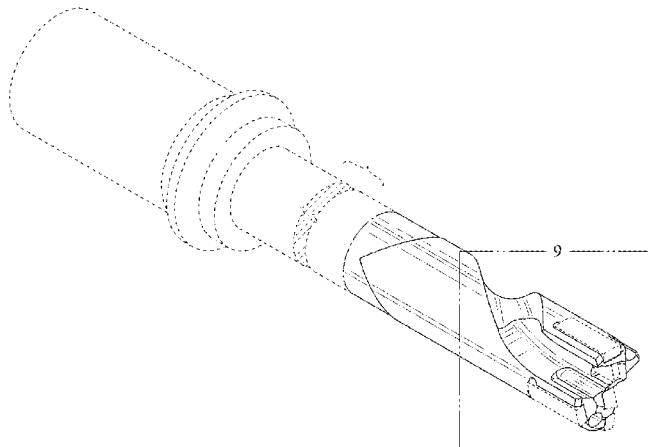

(56)

**References Cited**

U.S. PATENT DOCUMENTS

D693,861	S	*	11/2013	Sato	.....	D15/139
D723,076	S	*	2/2015	Lampe	.....	D15/139
D756,430	S	*	5/2016	Park	.....	D15/139
D797,170	S	*	9/2017	Sharivker	.....	D15/139
D799,574	S	*	10/2017	Fothergill	.....	D15/139

\* cited by examiner

Fig. 1

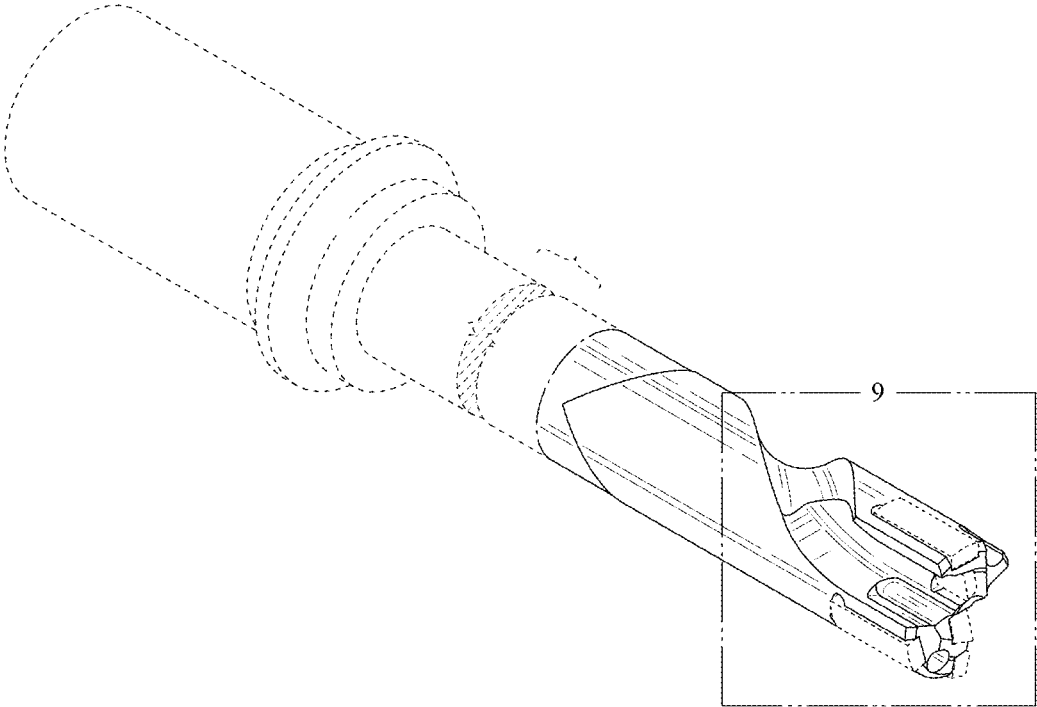

Fig. 2

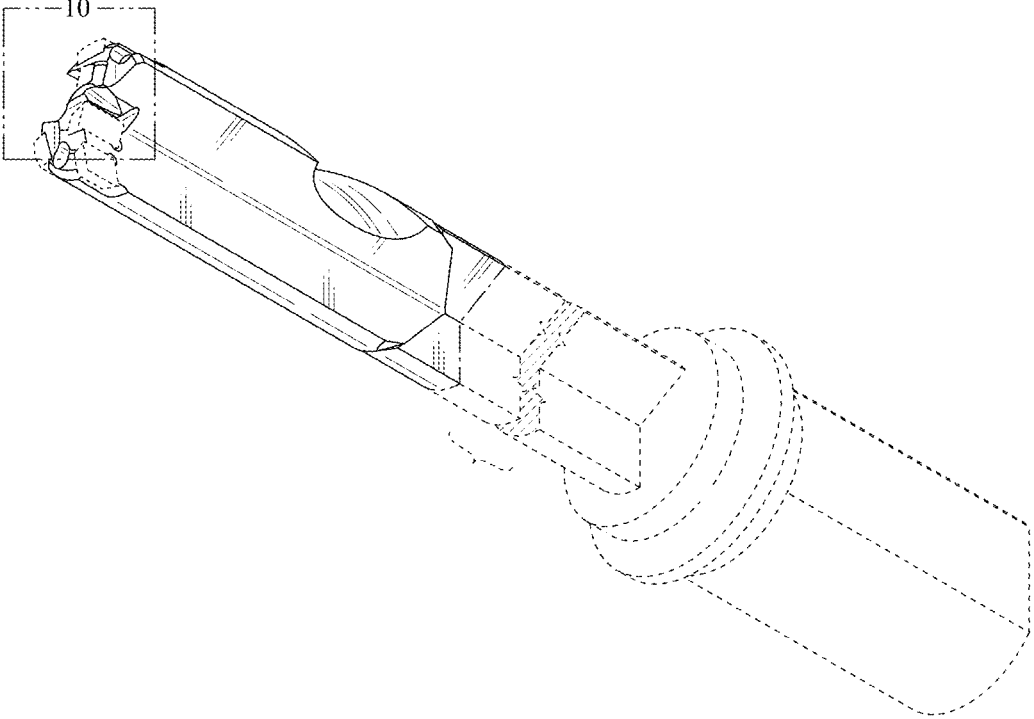

Fig. 3

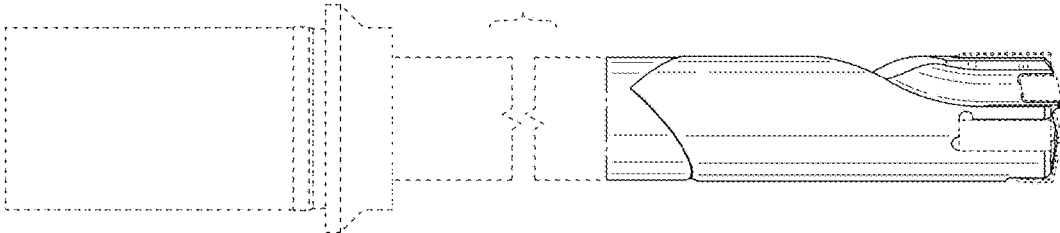

Fig. 4

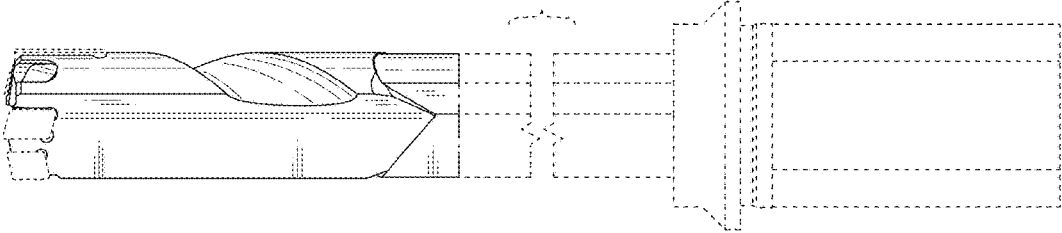

Fig. 5

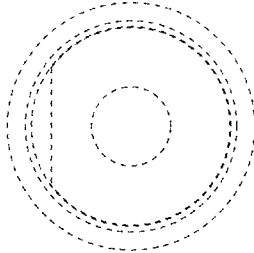

Fig. 6

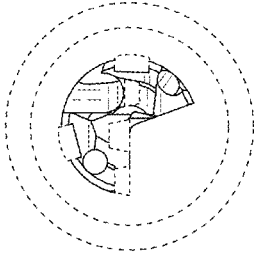

Fig. 7

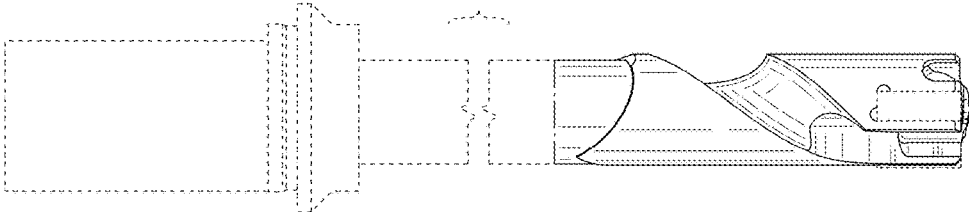

Fig. 8

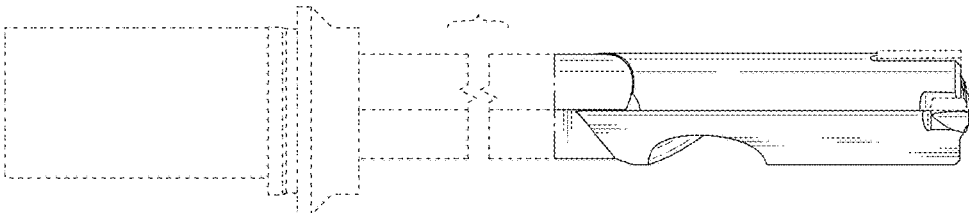

Fig. 9

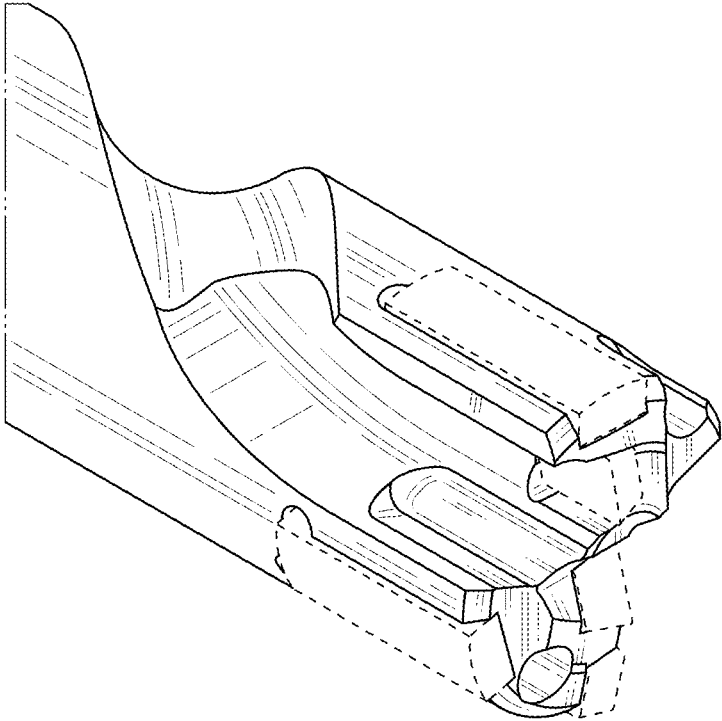



Fig. 10

