



US006026017A

United States Patent [19]
Wong et al.

[11] **Patent Number:** **6,026,017**
[45] **Date of Patent:** **Feb. 15, 2000**

- [54] **COMPACT NONVOLATILE MEMORY**
- [75] Inventors: **Ting-wah Wong**, Cupertino; **David Kuan-Yu Liu**; **Kelvin YuPak Hui**, both of Fremont, all of Calif.
- [73] Assignee: **Programmable Silicon Solutions**, Sunnyvale, Calif.
- [21] Appl. No.: **09/189,249**
- [22] Filed: **Nov. 10, 1998**

- [56] **References Cited**
- U.S. PATENT DOCUMENTS

4,953,928	9/1990	Anderson et al.	257/321
5,587,947	12/1996	Chang et al.	365/185.3
5,659,500	8/1997	Mehrad	365/185.05
5,867,425	2/1999	Wong	365/185.08
5,872,732	2/1999	Wong	365/185.18
5,896,315	4/1999	Wong	365/185.01
5,926,418	7/1999	Wong	365/185.28

Primary Examiner—David Nelms
Assistant Examiner—Gene N. Auduong
Attorney, Agent, or Firm—Trop, Pruner, Hu & Miles, P.C.

Related U.S. Application Data

- [63] Continuation-in-part of application No. 08/838,854, Apr. 11, 1997.
- [51] **Int. Cl.⁷** **G11C 16/04**
- [52] **U.S. Cl.** **365/185.05**; 365/185.1; 365/225.6
- [58] **Field of Search** 365/185.01, 185.05, 365/185.1, 185.14, 185.18, 225.6; 257/321, 575

[57] **ABSTRACT**

A nonvolatile memory cell which is highly scalable includes a cell formed in a triple well. A pair of sources for a pair of cells on adjacent word lines each acts as the emitter of a lateral bipolar transistor. The lateral bipolar transistor of one cell operates as a charge injector for the other cell. The charge injector provides carriers for substrate hot carrier injection onto a floating gate.

5 Claims, 4 Drawing Sheets

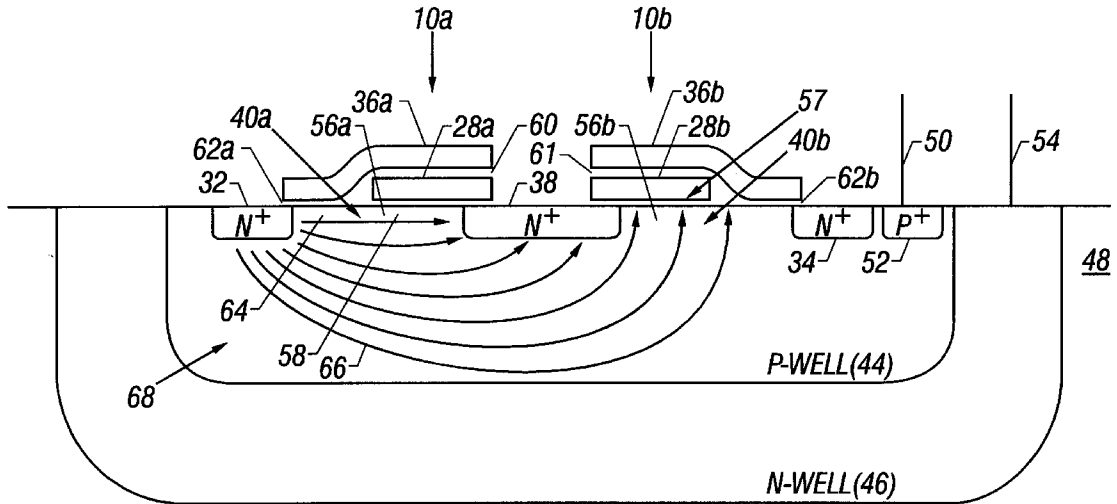

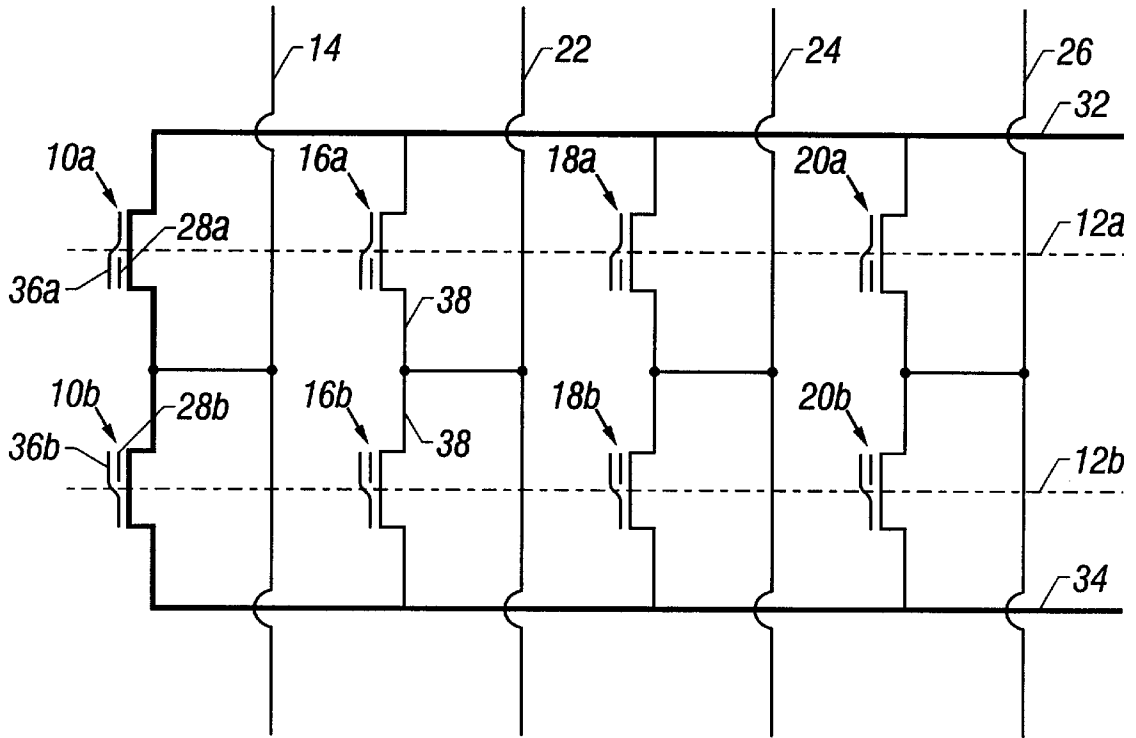

FIG. 1

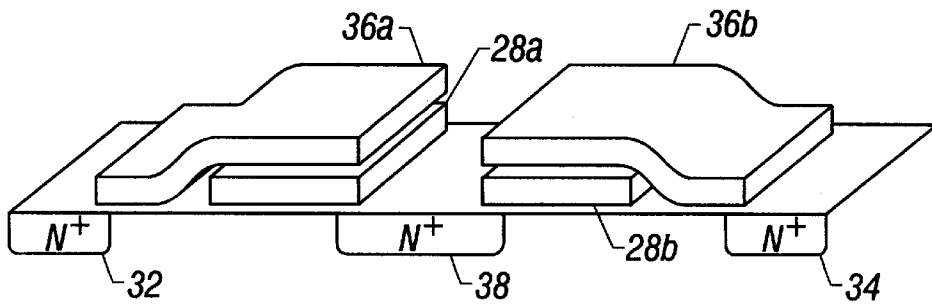

FIG. 4

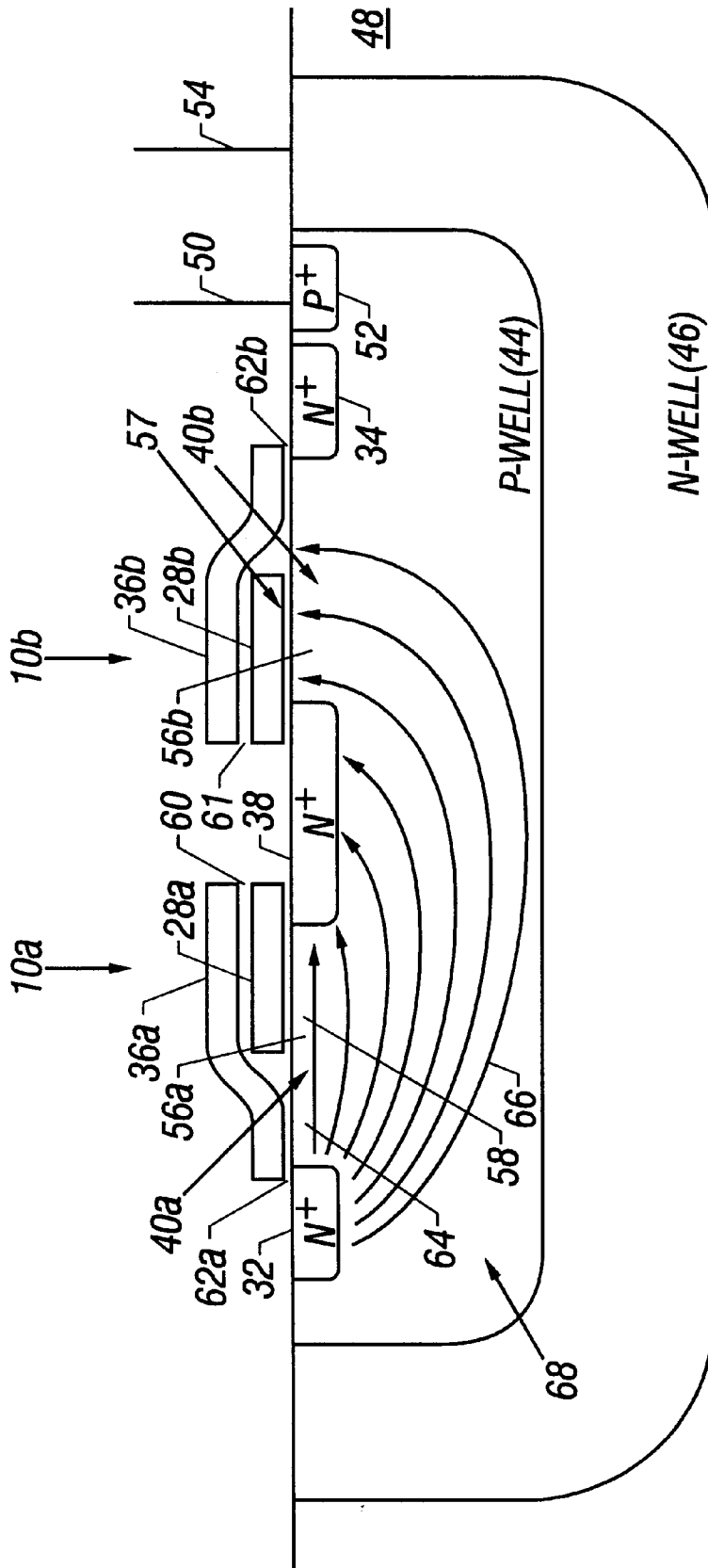

FIG. 2

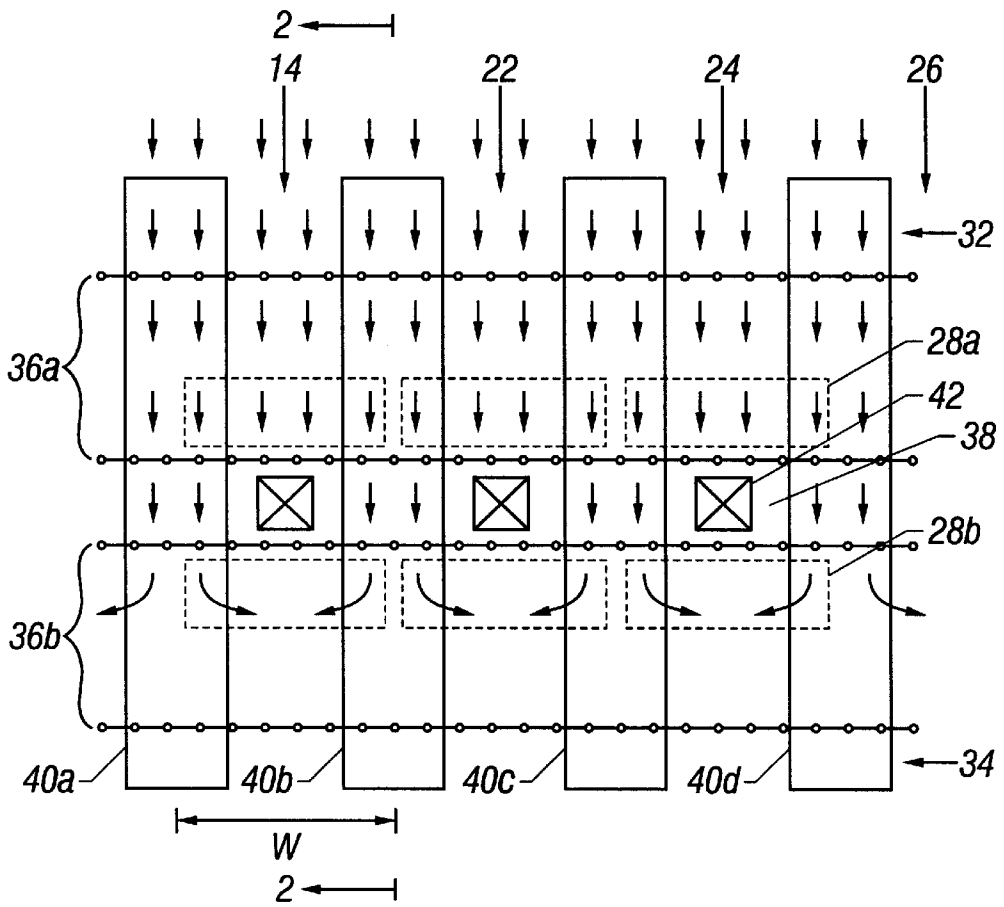

FIG. 3

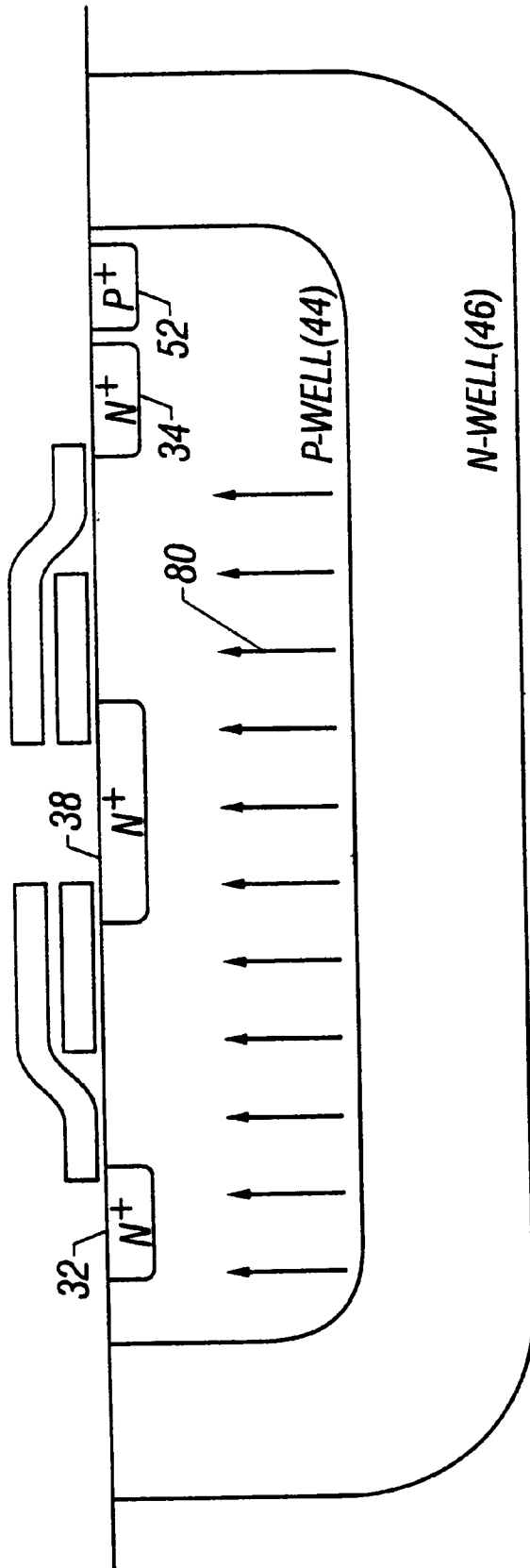

FIG. 5

COMPACT NONVOLATILE MEMORY

This is a continuation-in-part of copending application Ser. No. 08/838,854, filed Apr. 11, 1997.

BACKGROUND

This invention relates generally to nonvolatile memories and particularly to electrically erasable nonvolatile memories.

Nonvolatile memory cells are advantageous since they retain recorded information even when the power to the memory is turned off. There are several different types of nonvolatile memories including erasable programmable read only memories (EPROMs), electrically erasable and programmable read only memories (EEPROMs) and flash EEPROM memories. EPROMs are erasable through light exposure but are electrically programmable by channel hot electron injection onto a floating gate. Conventional EEPROMs have the same programming functionality, but instead of being light erasable they can be erased and programmed by electron tunneling facilitated by an on-chip electrical signal. Thus, information may be stored in these memories, retained when the power is off, and the memories may be erased for reprogramming, as necessary, using appropriate techniques. Flash EEPROMs may be block erased, typically giving them better read access times than regular EEPROMs.

Currently, flash memories have gained considerable popularity. For example, flash memories are often utilized to provide on-chip memory for microcontrollers, modems and SMART cards and the like where it is desirable to store codes that may need fast updating.

While flash memories and EEPROMs are closely related, in many instances, flash memories are preferred because their smaller cell size means that they can be made more economically. However, flash memories and EEPROMs often have very similar cell attributes.

Nonvolatile memory cells differ in certain respects from the transistors that are generally utilized in electronic components called logic devices, such as microcontrollers, that work with the memory cells. Logic devices are formed of transistors that use a single gate electrode. Nonvolatile memories usually include two gate electrodes, known as the control and floating gate electrodes, situated one adjacent to the other. Because of this structural difference, nonvolatile memories and logic devices may be made by different processes. This may contribute to a substantial increase in process complexity and manufacturing cost when the two components need to be placed together into the same chip.

Particularly with an EEPROM, the electrical programming of the cells normally requires substantial potentials to be applied to the cells. These potentials induce electron tunneling from an N+ region onto the floating gate. Additional complexity may arise from the need to provide substantially larger voltages to memory cells than are needed for normal logic transistor operation.

While the industry has come to accept the need for separate process technologies for logic and nonvolatile memories and while those in the industry have also come to appreciate that significant currents are needed to program flash EEPROMs, there would be a substantial demand for a nonvolatile memory which was both electrically erasable and programmable without the need for special process technologies or for relatively higher programming voltages and higher currents.

Furthermore, with the conventional flash EEPROMs, the electrical programming of the cells normally requires high

current to be applied to the cells. A very minute fraction of this electron current becomes injected from the drain depletion region onto the floating gate. This means that the injection efficiency of such devices is low (e.g., 1×10^{-6} to 1×10^{-9}). The requirement of high current adds additional complexity because of the design of the high current pump operated at low voltage.

SUMMARY OF THE INVENTION

In accordance with one embodiment, a memory array including word lines and bit lines includes a first and second cell, each having a control gate, floating gate and a source formed in a substrate. The control gate is situated over the floating gate. The cells are each adapted to form a depletion region in the substrate. A drain is situated between the first and second cells, each of the cells being part of a different word line.

BRIEF DESCRIPTION OF THE DRAWING

FIG. 1 is a schematic depiction of an array configuration for one embodiment;

FIG. 2 is a cross-sectional view taken generally along the line 3—3 in FIG. 3;

FIG. 3 is a greatly enlarged, top plan view showing the layout of a semiconductor implementation of the embodiment shown in FIG. 1;

FIG. 4 is a partial three dimensional view of the cell shown in FIG. 3; and

FIG. 5 is a cross-sectional view of another embodiment.

DESCRIPTION OF THE PREFERRED EMBODIMENT

Referring to the drawing wherein like reference characters are used for like parts throughout the several views, a pair of memory cells **10a** and **10b**, shown in FIG. 1, are located in two adjacent word lines **12a** and **12b**. The cells **10** are both arranged on the same bit line **14**. Other cells **16**, **18**, and **20** are arranged on bit lines **22**, **24**, and **26** and word lines **12**. This structure is advantageously implemented on a semiconductor layer having situated thereon electrically isolated floating gates **28**.

The source terminal **30** of each cell **10**, **16**, **18** and **20** is controlled by a source **32** or **34**. The control gates **36a** and **36b** of the cells **10**, **16**, **18** and **20** are controlled by the word lines **12**. The drains **38** of the cells are connected to the bit lines **14**, **22**, **24** and **26**.

One layout for implementing a pair of cells **10**, shown in FIG. 2, includes a pair of control gates **36a** and **36b**. The same layout may be used for the other pairs of cells **16**, **18** and **20**. The control gates **36** extend across a field oxide isolation region **40** which is bordered by the drain **38** on one side and the source **32** and **34** on the other side. The floating gates **28a** and **28b** are situated in isolation under the control gates **36a** and **38a**, over the oxide isolation region **40**.

In the illustrated embodiment, the active areas under the bit lines are P-type semiconductor material and are part of a P-well **44**. The P-well **44** in turn is formed in an N-well **46**. Finally, the N-well **46** is formed in a P-type substrate **48**. The P-well **44** may be biased, as indicated at **50** through a heavily doped P-type contact **52**, and the N-well **46** may be biased, as indicated at **54**.

Each floating gate **28** forms a tunneling capacitor **57** by its interaction with the channel **58**. A tunnel dielectric **56** separates the floating gate **28** from the channel **58**. Similarly

the interpoly dielectric **60** which is part of a coupling capacitor **61**, separates the floating gate **28** from the control gate **36**. Finally, the control gate **36** is separated by the dielectric **62** from the channel **64**.

The physical relationship of the cells **10**, **16**, **18** and **20** is illustrated in FIG. **3**. The floating gates **28** are shown in dashed lines. Similarly, the control gates **36** span between the drain **38** and a source **32** or **34**. Drain contacts **42** are located between the control gates **36** and bit lines **14**, **22**, **24** and **26**. Bit lines **14**, **22**, **24** and **26** extend transversely to the control gates **36**.

The cell **10** may be described as a flash EEPROM utilizing high efficiency substrate hot electron injection for erasure and Fowler-Nordheim tunneling for programming. The process of substrate hot electron injection is well described in T. H. Ning, C. M. Osburn, and H. W. Yu, "Emission Probability of Hot Electrons from Silicon into Silicon Dioxide," J. Appl. Phys., vol. 48, p. 286 (1977); Boaz Eitan, James L. McCreary, Daniel Amrany, Joseph Shappir, "Substrate Hot-electron Injection EPROM," IEEE Transactions on Electron Devices, Vol. ED-31, No. 7, p. 934 (July 1984); I. C. Chen, C. Kaya, and J. Paterson, "Band-to-Band Tunneling Induced Substrate Hot-electron (BBISHE) Injection: A New Programming Mechanism for Nonvolatile Memory Devices," IEDM (1989) p. 263; and C. Y. Hu, D. L. Kencke, S. K. Benerjee, "Substrate-current-induced Hot Electron (SCIHE) Injection: A New Convergence Scheme for FLASH Memory," IEDM (1995), P. 283. Each of these articles is hereby expressly incorporated by reference herein.

The cells are erased by causing charge to accumulate on the floating gates **28** and programming is achieved when charge is removed from the floating gates. Thus, initially all of the cells have accumulated charges on their floating gates. All of the cells **10**, **16**, **18**, and **20** are erased together using block erasing.

Erasing is achieved by high efficiency substrate hot carrier injection. As indicated in FIG. **2**, substrate carriers such as the electrons, indicated by the arrows at **66**, may be generated by forward biasing a source **32** or **34**. That is, the source of one cell acts as the injector for the other cell of a pair of cells **10**, **16**, **18**, or **20**. Thus, the source **32** acts as an injector for the cell **10b** being erased in FIG. **2**. Similarly, the source **34** acts an injector for the cell **10a** when the cell **10a** is being erased.

The source **32** is separated from the cell **10b** by the channels **64a** and **58** and the drain **38**. Some of the substrate electrons **66** diffuse through these regions to the channel region **56b** underneath the cell **10b**. Some electrons are ineffectively taken by the drain **38**.

For cells that need to be erased, the channel region **56** may be biased such that a depletion region is formed. When an electron gets to the depletion region, it is accelerated by an electric field, Vcs. The electric field Vcs is the difference between the channel potential (potential of the surface inversion region) and the P-well **44** potential. Some of these electrons gain sufficient energy, in excess of the effective oxide barrier height potential, to be injected onto the floating gate **28b**.

For cells that are not to be erased, the channel-to-P-well potential is less than the effective oxide barrier height. In such case, the electrons would not gain sufficient energy to overcome the barrier height and are not injected onto the floating gate **28**.

In the case when flash erase is desired, a scheme exists where all the cells inside the same P-well can be erased

together. This is achieved by forward-biasing the P-well **44** with respect to the N-well **46**. Electrons are injected from the bottom of the P-well **44** as indicated by the arrows **80**, and are collected by either the floating gate or the drain as shown in FIG. **5**.

The heavily doped N-type source **32**, the P-type regions **64a** and **56a** under the cell **10a**, the region under the drain **38** and the cell **10b** channel **56b**, form a lateral bipolar transistor **68**. The emitter (source **32**) of the bipolar transistor **68** acts as a charge injector, injecting substrate electrons from the source to the biased depletion region under the floating gate **28b**. With the source **32** as the emitter and the channels **68a**, **56a** and the region under the drain **38** as the base, the collector is the biased depletion region **56b**.

A compact cell layout is achieved because separate select transistors are unnecessary and the drain **38** acts as the drain for two adjacent cells in a pair of cells. The source of one cell also acts as the efficient injector for the other cell of a pair.

The efficiency of substrate hot electron injection is a function of a number of characteristics. Considering the depletion region **56b**, electrons scatter with lattice phonon scattering across the depletion region with a certain electron mean free path. Some of these electrons, without much scattering, gain sufficient energy to overcome the effective barrier height and are injected onto the floating gate **28**. Some electrons gain less energy than the effective barrier height and are not injected onto the floating gate **28**. The injection efficiency is a strong function of the doping concentrations and the channel-to-P-well potential, Vcs.

Since the cell **10** is situated in a P-well **44** embedded in an N-well **46**, during erasing the floating gate **28** is capacitively coupled to a high voltage by raising the potential on the bit lines, which may be biased to a potential from 7 to 14 volts. The voltage that the floating gate **28** attains at low drain bias is approximately a function of the voltage on the floating gate when the control gate **36b** and the P-well **44** and drain **38** are at ground, plus the coupling ration times the voltage on the control gate **36b**. The coupling ratio, to a first order, is approximately equal to the capacitance of the coupling capacitor **61** divided by the sum of the capacitances of the coupling capacitor **61** and the tunneling capacitor **57**.

When the cell **10a** is off, the drain **38** potential can be forced close to the supply potential Vcc or higher. The channel **56b** potential, which is the potential of the surface inversion region of the channel region, is set as follows. When the potential of the floating gate **28** (Vfg) is one cell threshold voltage higher than the drain **38** potential, the channel potential is the same as the drain potential. On the other hand, when the floating gate **28** potential is less than the drain **38** potential plus the cell threshold voltage, the channel potential is the difference between the floating gate **28** voltage and the cell threshold voltage.

The P-well potential is the voltage **50** applied to the P-well **44**. The P-well **44** is embedded in an N-well **46**, and the N-well is set at a voltage **54** of approximately Vss or higher, such as Vcc. Thus, the P-well potential can be Vss or negative, typically negative one to negative two volts. Moreover, P-well potential is usually less than the effective oxide barrier height to avoid any potential disturb problem.

The potential difference between the channel **56b** region and the P-well **44** potential **50** is the voltage across the depletion region. For cells to be erased, the drain **38** voltage is raised high, typically close to Vcc or higher. A depletion region underneath the cell being erased is formed with a voltage drop equal to the channel potential minus the P-well potential **50**.

For those cells that are not to be erased, the unselected word line voltage may be set to zero volts (V_{ss}). The voltage drop across the depletion region then is less than the effective oxide barrier height.

Cell **10** programming is achieved by Fowler-Nordheim tunneling of electrons from the floating gate **28** to the channel region **56b** and the drain **38**. During programming, the selected bit line **36b** is forced to a high voltage "H" (higher than V_{cc}) of about 5 volts, for example. The unselected bit lines are maintained at V_{ss} . If the N-well and P-well are maintained at V_{cc} and V_{ss} respectively, the electric field across the junction between the drain **38** and the P-well **44** may be reduced. The reduced field prevents acceleration of hot hole trapping in the gate oxide under the floating gate **28**.

Electrons tunnel to the drain **38** (drain programming). The tunneling current depends on the voltage from the floating gate **28** to the drain **38**. Reading the programming state of a cell may be accomplished as follows. The selected bit line is biased to approximately 0.7 to one volt. The rest of the bit lines are allowed to float. The source **32** may be biased to $-V_s$ and the source **34** may be biased to V_H . The selected word line is biased to V_{HH} and the adjacent word line is biased to $-V_s$. The P-well is biased to V_{ss} and the N-well is biased at V_{cc} . V_s is the node voltage set by the injection current level, ranging from a few tens of nanoamps to a few tens of microamps depending on the programming speed requirement. Typically it would be from tens of milliseconds to tens of microseconds. V_{ss} is the external ground potential.

When these potentials are applied to the selected cell **10**, a current flows through the cell. This current is then fed to a current sense amplifier (not shown). If the voltage on the floating gate **28** is greater than the threshold voltage on the sense transistor **12**, a higher current, perhaps greater than 20 microamps, is detected as the conducting state. When the potential of the floating gate is less than the threshold voltage, a lower current, for example, less than one microamp flows, and a nonconducting state is detected.

The source **32** is biased to $-V_s$ (i.e., a diode voltage drop, approximately 0.7 volts, for example) while the source **34** is at V_{HH} . V_{HH} may be from about 10 to 14 volts in one embodiment. The selected word line is biased to V_{HH} and the adjacent word line of the pair is $-V_s$. The P-well bias is $-V_{ss}$ and the N-well bias is V_{cc} .

The voltage across the capacitor **57** is the difference between the floating gate **28** potential on the one hand and the drain **38** and the P-well **44** potentials. When the difference exceeds 8 to 10 volts, sufficient tunneling current is generated and the floating gate **28** can be erased to a negative potential in the time frame of a few milliseconds to a few seconds, depending on the tunneling oxide **56** thickness.

A detected conducting state can be called a one state. A nonconducting state can be called the zero state.

A suitable on-chip circuit for generating two negative bias potentials, one to bias a word line **36** and the other to negatively bias the P-well **44**, can be found in L. A. Glasser and D. W. Dobberpuhl, "The Design and Analysis of VLSI Circuits," (December 1985), published by Addison-Wesley, at pages 301-329, hereby expressly incorporated by reference herein.

The cells in the array may be formed using conventional process technologies such as double poly, single metal CMOS process. The illustrative parameters set forth herein contemplate a 0.25 μ m or lower feature size with V_{cc} potentials of 1.8 volts. As the technology permits lowering voltages and smaller feature sizes, the parameters herein would scale accordingly.

The starting substrate material is typically P-type (100) silicon, for example having a resistivity in the range of 10-20 ohm-cm. The P-well **44** is embedded in an N-well **46** in the so-called triple well process. The P-well **44** has a typical well depth of, for example, 2 to 4 μ m with an average doping concentration, for example, in the range of 1×10^{16} to 5×10^{16} atoms per cubic centimeter.

The N-well **46** has a typical well depth of, for example, 4-8 μ m. The doping concentration may be from 4×10^{15} to 1×10^{16} atoms per cubic centimeter. The triple well is formed by the P-well **44** counterdoping the N-well **46**.

The formation of the elements in the triple well is as follows. An N-well implant is done, for example, with phosphorous 31 with a typical dose of 1 to 1.5×10^{13} atoms per square centimeter and an energy of 160 to 100 Kev. The N-well **46** is then counterdoped with a P-well implant. Typical dosages for the P-well implant could be 1.5 to 2.5×10^{13} atoms per square centimeter with an energy of 30 Kev to 180 Kev using a species such as boron 11. The N-well **46** and P-well **28** are then driven, typically 6 to 10 hours at 1125 to 1150° C. This sets the wells to the desired doping concentrations and depths.

After the well formation, standard logic field oxide formation and channel stop formation steps are applied. The field oxide thickness and implant doses are adjusted to achieve a field threshold of 7 to 14 volts, which is determined by the level for programming and erasing and by logic process capability. After this formation, a memory cell implant may be performed. For example, a B11 implant at 30 to 50 Kev with a dose of 1.5 to 3×10^{13} atoms per square centimeter may be done through a sacrificial oxide. The gate oxide **62a** and the tunnel oxide **56** are then formed. For example, an 85 to 100 Angstrom dry oxide may be grown across the wafer. A dry oxide is grown, for example, at 900° C in partial oxygen followed by a 975 to 1050° C. anneal.

The floating gate **28** may then be formed of polysilicon, silicide or metals. If polysilicon is used, it can be 1600 Angstroms thick, and POCL3 doped at 870 to 1000° C. The interpoly dielectric is formed of an oxide-nitride-oxide sandwich (ONO) with the lower oxide being from 60 to 80 Angstroms, the nitride layer having a thickness of from 90 to 180 Angstroms and the upper oxide being from 30 to 40 Angstroms.

After floating gate and select gate definition, a N+ implant is implanted into the sources. The N+ implant can be, for example, a phosphorous implant at 60 Kev, at a dose of 1 to 3×10^{14} atoms per square centimeter may be followed by arsenic at 60 Kev, 2.5 to 4.5×10^{15} atoms per square centimeter. It is also possible to form the source and drain using lightly doped drain (LDD) technology.

The polysilicon (poly 2) for the control gate may then be deposited and silicided if desired. The gates are patterned and defined using standard techniques. The control gate is not self-aligned to the sense and select gates.

With the completion of these capacitor and transistor structures, all subsequent processing for contacts and interconnect layers follows standard logic rear end processing.

Referring again to FIG. 2, the flow of electron current from the injector, which in the illustrated embodiment is the source **32**, to a floating gate **28b** is shown. The substrate electrons, indicated by arrows, may flow from the source **32** along the entire width "W" of the cell between adjacent isolation regions **40**. In addition, electrons flow from the portions **32a** and **32b** extending beyond the cell width. Namely, the portions of the source **32** extending to either side of the cell in the width direction also contribute elec-

trons which may be utilized to program the floating gate 28. This may significantly increase the available electron current for erasing and thus may expedite erasing.

This arrangement is possible because the heavily doped N-type sources 32 and 34 run parallel to the control gates 36. In other words, the sources 32 and 34 run parallel to the word lines or rows of the array. Because of this geometry, a portion of the source which is greater in length than the width of the cell may be utilized for erasing purposes. Namely, additional electrons may flow from the extensions 10a and 10b between adjacent columns of cells.

The operation of one embodiment of the invention is illustrated in the following mode table:

	Selected B/L	Unselected B/L	Source 1	Source 2	Next to Selected WL	Selected WL
Erase	H	H	-V _S	V _H	-V _S	V _{HH}
Prog.	H	V _{SS}	Float	Float	V _{SS}	-V _{HH}
Read	.7-1.0 V	Float	V _{SS}	V _{SS}	V _{SS}	V _{CC}
Flash	H	H	-V _S	-V _S	V _{HH}	V _{HH}
Erase						

While a number of parameters and levels were provided in the foregoing description, those skilled in the art will appreciate that these parameters and levels are merely for illustration purposes. For example, by reversing the conductivity types of the doped junctions and the bias polarities, a cell structure using substrate hot hole injection may be implemented. In addition, charge injection may be used for programming rather than erasing as disclosed in the illus-

trated embodiment. It is intended that the appended claims cover all modifications and variations as fall within the true spirit and scope of the present invention.

What is claimed is:

1. A memory array including word lines and bit lines, said array comprising:

a first and second cell, each having a control gate, a floating gate and a source formed in a substrate, said control gate situated over said floating gate, said cells each adapted to form a depletion region in said substrate;

a drain situated between said first and second cells, each of said cells being part of a different word line; and

a pair of bipolar transistors, each bipolar transistor formed from a source of one of a first and second cells, one of the channels of said first and second cells and the biased depletion under the channel of one of said first and second cells.

2. The array of claim 1 wherein said cells do not use a separate select transistor.

3. The array of claim 1 wherein including a P-well that is biased to V_{SS} or negative and said cells are N-channel transistors.

4. The array of claim 3 including an N-well, said P-well formed in said N-well, said N-well being positively biased.

5. The array of claim 1 which is programmed by removing charge from the floating gate and which is erased by adding charge to the floating gate.

* * * * *

UNITED STATES PATENT AND TRADEMARK OFFICE
CERTIFICATE OF CORRECTION

PATENT NO. : 6,026,017

DATED : February 15, 2000

INVENTOR(S) : TING-WAH WONG, DAVID KUAN-YU LIU and KELVIN YUPAK HUI

It is certified that error appears in the above-identified patent and that said Letters Patent is hereby corrected as shown below:

In column 8, line 19, after "depletion" please insert --region--.

Signed and Sealed this
Twelfth Day of December, 2000

Attest:



Q. TODD DICKINSON

Attesting Officer

Director of Patents and Trademarks