

(12) STANDARD PATENT
(19) AUSTRALIAN PATENT OFFICE

(11) Application No. **AU 2019283937 B2**

(54) Title
WOUND DRESSING AND METHOD OF TREATMENT

(51) International Patent Classification(s)
A61F 13/00 (2006.01) **A61F 13/02** (2006.01)

(21) Application No: **2019283937** (22) Date of Filing: **2019.12.19**

(43) Publication Date: **2020.01.23**

(43) Publication Journal Date: **2020.01.23**

(44) Accepted Journal Date: **2021.11.25**

(62) Divisional of:
2017210626

(71) Applicant(s)
Smith & Nephew plc

(72) Inventor(s)
ALLEN, Julie;ASKEM, Ben Alan;COLLINSON, Sarah Jenny;MEHTA, Steven Carl;GOWANS, Philip;NICOLINI, Derek;ZAGRABSKI, Carol

(74) Agent / Attorney
Griffith Hack, Level 10 161 Collins St, MELBOURNE, VIC, 3000, AU

(56) Related Art
US 2008/0132821 A1
US 5562107 A
US 2001/0051165 A1
US 2010/0137775 A1
WO 2001/054743 A1
EP 0768071 A1
US 8372049 B2
US 2010/0312159 A1

WOUND DRESSING AND METHOD OF TREATMENT

ABSTRACT OF THE DISCLOSURE

Embodiments disclosed herein are directed to negative pressure treatment systems and wound dressing systems, apparatuses, and methods that may be used for the treatment of wounds. In particular, some embodiments are directed to improved wound dressings comprising an obscuring layer that may hide fluid contained therein. Some embodiments may further comprise one or more viewing windows disposed therethrough so as to enable monitoring or examination of fluids contained therein.

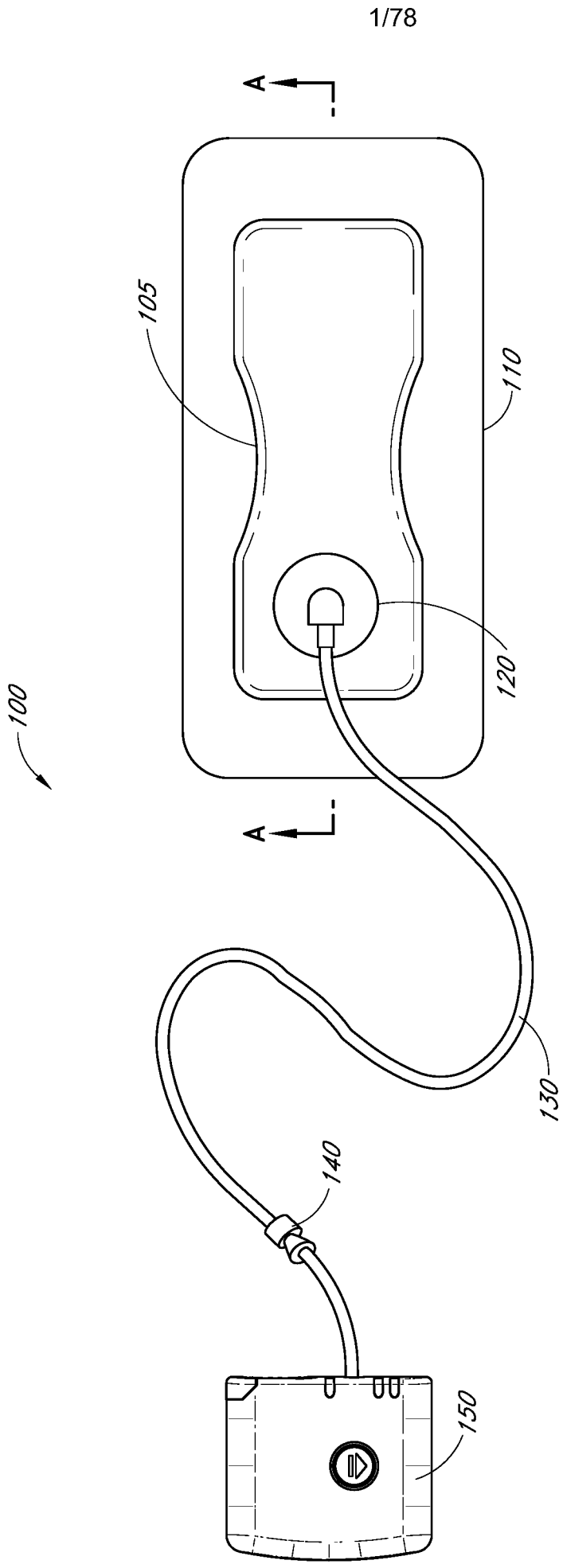

FIG. 1

WOUND DRESSING AND METHOD OF TREATMENT

CROSS-REFERENCE TO RELATED APPLICATIONS

[0001] This application is a divisional application of Australian Application No. 2017210626, which in turn is a divisional application of AU2013298198. The original disclosures of the applications are incorporated herein by reference. This application also claims the benefit of U.S. Provisional Application Serial No. 61/678,569, filed August 1, 2012, titled "WOUND DRESSING AND METHOD OF TREATMENT," U.S. Provisional Application Serial No. 61,753,374, filed January 16, 2013, titled "WOUND DRESSING AND METHOD OF TREATMENT," U.S. Provisional Application Serial No. 61/753,878, filed January 17, 2013, titled "WOUND DRESSING AND METHOD OF TREATMENT," and U.S. Provisional Application Serial No. 61/785,054, filed March 14, 2013, titled "WOUND DRESSING AND METHOD OF TREATMENT," the entireties of each of which are hereby incorporated by reference.

BACKGROUND OF THE INVENTION

Field of the Invention

[0002] Embodiments described herein relate to apparatuses, systems, and methods the treatment of wounds, for example using dressings in combination with negative pressure wound therapy.

Description of the Related Art

[0003] Prior art dressings for use in negative pressure have been difficult to apply, particularly around curved or non-flat body surfaces. Further, when used, wound exudate may soak into the dressing, which some patients may find aesthetically unpleasing and difficult to address in social situations.

SUMMARY OF THE INVENTION

[0004] Accordingly, certain embodiments disclosed herein relate to improved wound dressing that exhibit enhanced conformability and aesthetic presentation. Also disclosed are improved methods of use and systems for use of the same, preferably in conjunction with negative pressure wound therapy.

[0004a] According to one aspect, there is provided an apparatus for dressing a wound comprising:

a substantially rectangular or square fibrous absorbent layer having one or more slits configured to enhance conformability when the apparatus is applied to a non-planar or contoured wound area, the one or more slits extending at least partially across the width of the absorbent layer;

a fibrous acquisition distribution layer positioned below the absorbent layer; and
a backing layer above the absorbent layer;

[0004b] According to another aspect, there is provided an apparatus for dressing a wound comprising:

a substantially rectangular or square fibrous absorbent layer having one or more slits configured to enhance conformability when the apparatus is applied to a non-planar or contoured wound area, the plurality of slits extending at least partially across the absorbent layer and intersecting with an edge of the absorbent layer;

a cover layer positioned over the absorbent layer, the cover layer extending beyond the boundary of the absorbent layer and configured to seal to skin surrounding a wound.

[0005] Disclosed herein is also a wound treatment apparatus for treatment of a wound site comprises:

a wound dressing comprising:

an absorbent layer configured to retain fluid,

a backing layer above the absorbent layer, and

an obscuring layer configured to at least partly visually obscure fluid within the absorbent layer; and

a fluidic connector configured to transmit negative pressure from a negative pressure source to the wound dressing for the application of topical negative pressure at the wound site.

[0006] In some embodiments, the obscuring layer is above or below the backing layer. The obscuring layer may be configured to at least partially visually obscure fluid contained within the absorbent layer. The obscuring layer may comprise at least one viewing window configured to allow a visual determination of the saturation level of the absorbent layer. The at least one viewing window may comprise at least one aperture made through the obscuring layer. The at least one viewing window may comprise at least one uncolored region of the obscuring layer. The viewing window may comprise an array of dots. The array of dots may be distributed in a straight line of dots, the straight line of dots being positioned on a center line along a length of the absorbent layer. The straight line of dots may comprise an array of three dots. The straight line of dots may

comprise an array of five dots. The straight line of dots may comprise an array of eight dots. The array of dots may be distributed in two straight lines of dots, the two straight lines of dots positioned to be an equal distance from a center line along a length of the absorbent layer, the two straight lines of dots having an equal number of dots. The two straight lines of dots may comprise an array of three dots. The two straight lines of dots may comprise an array of five dots. The array of dots may be distributed regularly over the obscuring layer to enable assessment of wound exudate spread. The viewing window may be selected from the group consisting of a graphical element or a typographical element. The obscuring layer may comprise an auxiliary compound, wherein the auxiliary compound may comprise activated charcoal configured to absorb odors and configured to color or tint the obscuring layer. The fluidic connector may comprise an obscuring element configured to substantially visually obscure wound exudate.

[0007] Some embodiments may further comprise an acquisition distribution layer between the wound contact layer and the absorbent material. The absorbent layer may comprise cellulose fibers and between 40% and 80% (or between about 40% and about 80%) superabsorbent particles. The obscuring layer, in a dry state, may be configured to yield a CIE y value of .4 or less and a CIE x value of .5 or less on a CIE x, y chromaticity diagram. The obscuring layer, in a dry state, may have a color of Bg, gB, B, pB, bP, P, rP, pPk, RP, O, rO, or yO on a CIE x, y chromaticity diagram.

[0008] In some embodiments, the wound dressing further comprises an orifice in the backing layer, the orifice configured to communicate negative pressure to the wound site. The obscuring layer may comprise at least one orifice viewing window configured to be positioned adjacent to the orifice in the backing layer, the orifice viewing window configured to allow a visual determination of the saturation level of the absorbent layer adjacent to the orifice. The orifice viewing window may be cross-shaped. The wound dressing may comprise a first length corresponding to a first edge of a wound dressing and a first width corresponding to a second edge of the wound dressing, a first x axis runs along the first width and a first y axis runs along the first length, wherein the first x axis and the first y axis are in a perpendicular alignment. The viewing window may comprise a first arm and a second arm, the first arm of the viewing window define a second length and the second arm defines a second width, a second x axis runs along the second width and a second y axis runs along the second length, wherein the second x axis and the second y axis are in a perpendicular alignment. The second x axis and second y

axis of the viewing window is offset from the first x axis and the first y axis of the absorbent layer. The second x axis and second y axis of the viewing window may be aligned with the first x axis and the first y axis of the absorbent layer. The cross-shaped viewing window may comprise flared ends. The fluidic connector may be configured to transmit air. The fluidic connector may comprise a filter, the filter configured to block fluid transport past itself. The fluidic connector may comprise a secondary air leak channel, the secondary air leak channel configured to allow a flow of ambient air to the wound site. The secondary air leak channel may comprise a filter. The fluidic connector may comprise a soft fluidic connector. The soft fluidic connector may comprise a three dimensional fabric. In some embodiments, the three dimensional fabric is configured to transmit therapeutic levels of negative pressure while an external pressure up to 2 kg/cm^2 is applied thereto. The soft fluidic connector may be configured to be connected to a tube in fluid communication with the vacuum source. The soft fluidic connector may be configured to be connected directly to the vacuum source. The soft fluidic connector may comprise an enlarged distal end, the enlarged distal end configured to be connected to the wound dressing. The apparatus may further comprise a tube connected to the fluidic connector. The apparatus may further comprise a pump in fluid communication with the fluidic connector. In some embodiments, the absorbent layer comprises two or more lobes.

[0009] Disclosed herein is also a wound treatment apparatus for treatment of a wound site comprises:

- a wound dressing configured to be positioned over a wound site, the wound dressing comprising:

- a backing layer having an upper surface and a lower surface and defining a perimeter configured to be positioned over skin surrounding the wound site, the backing layer including an opening;

- a wound contact layer adhered to the lower surface of the backing layer, the wound contact layer comprising an adhesive on a lower surface thereof;

- an absorbent material positioned between the backing layer and the wound contact layer, wherein the absorbent material comprises a vertical hole positioned below the opening in the backing layer;

an obscuring layer positioned at least partially over the absorbent material, wherein the obscuring layer comprises a vertical hole positioned between the opening in the backing layer and the vertical hole in the absorbent material;

one or more viewing windows extending through the obscuring layer configured to allow visualization of wound exudate in the absorbent material; and

a port positioned over the opening in the backing layer configured to transmit negative pressure through the port for the application of topical negative pressure at the wound site.

[0010] In some embodiments, the backing layer is transparent or translucent. The backing layer may define a perimeter with a rectangular or a square shape. The wound contact layer may be adhered to the lower surface of the backing layer along the perimeter of the backing layer. The hole in the obscuring layer may have a different diameter than the hole in the absorbent material or the opening in the backing layer. The one or more viewing windows may be arranged in a repeating pattern across the obscuring layer. The one or more viewing windows may have a circular shape.

[0011] Some embodiments may further comprise an acquisition distribution layer between the wound contact layer and the absorbent material. The absorbent layer may comprise cellulose fibers and between 40% and 80% (or between about 40% and about 80%) superabsorbent particles. The obscuring layer, in a dry state, may be configured to yield a color of Bg, gB, B, pB, bP, P, rP, pPk, RP, O, rO, or yO on the CIE x, y chromaticity diagram.

[0012] Some embodiments further comprise a transmission layer between the absorbent material and the wound contact layer. In some embodiments, the apparatus further comprises a hydrophobic filter positioned in or below the port. The absorbent material may have a longitudinal length and a transverse width, wherein the length is greater than the width, and wherein the width of the absorbent material narrows in a central portion along the longitudinal length of the absorbent material. The obscuring layer may have substantially the same perimeter shape as the absorbent material. The apparatus may further comprise a pump

[0013] Disclosed herein is also a wound treatment apparatus for treatment of a wound site comprises:

a wound dressing configured to be conformable to a nonplanar wound comprising:

an absorbent layer comprising a contoured shape, the contoured shape comprising a substantially rectangular body with a waisted portion, and

a backing layer above the absorbent layer; and

a fluidic connector configured to transmit negative pressure from a negative pressure source to the wound dressing for the application of topical negative pressure at a wound site.

[0014] Some embodiments may further comprise a wound contact layer. The backing layer may be rectangular. In some embodiments, the negative pressure source is a pump.

[0015] In some embodiments, the wound dressing has a longer axis and a shorter axis, and wherein the waisted portion configured to be on the longer axis. The apparatus may further comprise an obscuring layer configured to at least partly visually obscure fluid within the absorbent layer. The obscuring layer may comprise at least one viewing window configured to allow a visual determination of the saturation level of the absorbent layer. The viewing window may comprise an array of dots. The fluidic connector may be located along a side or corner of the rectangular body.

[0016] Some embodiments may further comprise an acquisition distribution layer between the wound contact layer and the absorbent material. The absorbent layer may comprise cellulose fibers and 40%-80% (or about 40% to about 80%) superabsorbent particles. The obscuring layer, in a dry state, may be configured to yield a color of Bg, gB, B, pB, bP, P, rP, pPk, RP, O, rO, or yO on the CIE x, y chromaticity diagram.

[0017] Disclosed herein is also an apparatus for dressing a wound for the application of topical negative pressure at a wound site, comprises:

an absorbent layer having one or more slits extending at least partially across the width of the absorbent layer; and

a backing layer above the absorbent layer, the backing layer having an orifice for communicating negative pressure to the wound site, wherein the orifice is positioned over a portion of the absorbent layer having no slits.

[0018] In some embodiments, the one or more slits comprise one or more concentric arcs.

[0019] Disclosed herein is also a wound treatment apparatus comprises:

a wound dressing configured to be conformable to a nonplanar wound comprising:

an absorbent layer above the contact layer, the absorbent layer comprising a contoured shape, the contoured shape comprising two or more lobes, and

a backing layer above the absorbent layer.

[0020] In some embodiments, the wound treatment apparatus comprises a pump. The wound dressing may comprise a fluidic connector configured to transmit negative pressure from a pump to the wound dressing for the application of topical negative pressure at a wound site. The wound dressing may also comprise a wound-facing contact layer. The contoured shape may comprise three lobes. The contoured shape may comprise four lobes. The two or more lobes may comprise rounded projections. The apparatus may comprise two or more lobes flared lobes. The contoured shape may be oval-shaped. The contoured shape may comprise six lobes. The apparatus may further comprise an obscuring layer disposed so as to obscure the absorbent layer. The apparatus may further comprise an obscuring layer configured to at least partly visually obscure fluid within the absorbent layer. The obscuring layer may comprise at least one viewing window configured to allow a visual determination of the saturation level of the absorbent layer. The viewing window may comprise an array of dots.

[0021] Disclosed herein is also an apparatus for dressing a wound for the application of topical negative pressure at a wound site, comprises:

a wound contact layer;

an acquisition distribution layer above the wound contact layer;

an absorbent layer over the acquisition distribution layer, the absorbent layer comprising a matrix and superabsorbing particles within the matrix; and

a backing layer above the absorbent layer.

[0022] Some embodiments of the apparatus may further comprise a transmission layer between the wound contact layer and the acquisition distribution layer. The acquisition distribution layer may comprise viscose, polyester, polypropylene, cellulose, polyethylene or a combination of some or all of these materials. The absorbent layer may comprise between 30% and 40% (or between about 30% and about 40%) cellulose matrix and between 60% and 70% (or between about 60% and about 70%) superabsorbing polymers. The backing layer may be transparent or translucent.

[0023] Some embodiments may further comprise an obscuring layer between the absorbent layer and the backing layer. There may be one or more viewing windows in

the obscuring layer. At least the obscuring layer may be shaped with a narrowed central portion along its length. The obscuring layer may comprise two rows of three viewing windows, one row of three viewing windows, one row of eight viewing windows, two rows of five viewing windows, or one row of five viewing windows. At least the obscuring layer may be shaped with a narrowed central portion along both its width and its length. The obscuring layer may comprise a 3 x 3 array of viewing window or a quincunx array of viewing windows. In some embodiments, at least the obscuring layer may comprise a six-lobed shape. The absorbent layer and acquisition distribution layer may be substantially the same shape as the obscuring layer. The obscuring layer may further comprise a cross or maltese cross shaped hole over which a fluidic connector for transmitting negative pressure may be connected. The apparatus may further comprise a fluidic connector configured to connect the backing layer to a source of negative pressure.

[0024] Disclosed herein is also an apparatus for dressing a wound for the application of topical negative pressure at a wound site, comprises:

an absorbent layer configured to retain fluid,

a backing layer above the absorbent layer, and

an obscuring layer configured to at least partly visually obscure fluid within the absorbent layer, wherein the obscuring layer, in a dry state, is configured to yield a color of Bg, gB, B, pB, bP, P, rP, pPk, RP, O, rO, or yO on the CIE x, y chromaticity diagram.

[0025] Some embodiments may further comprise one or more viewing windows in the backing layer. At least the obscuring layer may be shaped with a narrowed central portion along its length. The obscuring layer may comprise a 3 x 3 array of viewing window or a quincunx array of viewing windows. In some embodiments, at least the obscuring layer may comprise a six-lobed shape. The absorbent layer and acquisition distribution layer may be substantially the same shape as the obscuring layer. The obscuring layer may further comprise a cross or maltese cross shaped hole over which a fluidic connector for transmitting negative pressure may be connected. The apparatus may further comprise a fluidic connector configured to connect the backing layer to a source of negative pressure.

BRIEF DESCRIPTION OF THE DRAWINGS

[0026] Figure 1 illustrates an embodiment of a wound treatment system;

[0027] Figures 2A-D illustrate the use and application of an embodiment of a wound treatment system onto a patient;

[0028] Figure 3A illustrates an embodiment of a wound dressing in cross-section;

[0029] Figure 3B illustrates another embodiment of a wound dressing in cross-section;

[0030] Figure 3C illustrates another embodiment of a wound dressing in cross-section;

[0031] Figures 4A-C illustrate a top view of an embodiment of a wound dressing with a narrow central portion;

[0032] Figures 5A-F - 12A-F illustrate a perspective view, a top view, a bottom view, a front view, a back view, and a side view, respectively, of embodiments of a wound dressing including an obscuring layer and viewing windows;

[0033] Figures 13A-B and 14 illustrate a top view of an embodiment of a wound dressing including a cross-shaped viewing window;

[0034] Figures 15A-B illustrate a top view of an embodiment of a wound dressing including slits in the wound dressing;

[0035] Figure 16 illustrates an embodiment of a dressing comprising a viewing window in the shape of a trademarked brand name;

[0036] Figure 17 illustrates a top view of an embodiment of a three-lobe configuration of a wound dressing and a dot pattern of viewing windows;

[0037] Figure 18 illustrates a top view of an embodiment of a three-lobe configuration of a wound dressing and viewing windows in the shape of a logo;

[0038] Figure 19 illustrates a top view of an embodiment of a three-lobe wound dressing;

[0039] Figure 20 illustrates a top view of an embodiment of a three-lobe wound dressing with flared ends on each lobe;

[0040] Figure 21A illustrates a top view of an embodiment of a four-lobe wound dressing with crescent shaped cut-outs as viewing windows;

[0041] Figure 21B illustrates a top view of an embodiment of a four-lobe wound dressing with an array of dots at viewing windows;

[0042] Figure 21C illustrates a top view of an embodiment of a four-lobe wound dressing with viewing windows;

[0043] Figure 22 illustrates a perspective view of an embodiment of a four-lobe wound dressing;

[0044] Figure 23A-B illustrate embodiments of white and colored fluidic connectors, respectively;

[0045] Figures 24A-F illustrate a perspective view, a top view, a bottom view, a front view, a back view, and a side view, respectively, of an embodiment of an oval-shaped wound dressing;

[0046] Figures 25-32 illustrate embodiments of a wound dressing including an obscuring layer and viewing windows including an orifice viewing window;

[0047] Figures 33A-B illustrate embodiments of an oval-shaped wound dressing comprising an obscuring layer and an orifice viewing window;

[0048] Figure 34A illustrates an exploded view of an embodiment of a wound dressing connectable to a soft port;

[0049] Figure 34B illustrates a cross sectional view of an embodiment of a wound dressing;

[0050] Figure 35 illustrates an exploded view of an embodiment of a soft or flexible port for transmitting negative pressure to a wound dressing;

[0051] Figure 36 illustrates an embodiment of a soft port attached to a wound dressing;

[0052] Figure 37A illustrates a perspective view of a wound dressing;

[0053] Figure 37B illustrates a bottom view of the wound dressing of Figure 37A; and

[0054] Figure 38 illustrates a CIE chromaticity scale.

DETAILED DESCRIPTION OF THE PREFERRED EMBODIMENTS

[0055] Embodiments disclosed herein relate to apparatuses and methods of treating a wound with reduced pressure, including pump and wound dressing components and apparatuses. The apparatuses and components comprising the wound overlay and packing materials, if any, are sometimes collectively referred to herein as dressings.

[0056] It will be appreciated that throughout this specification reference is made to a wound. It is to be understood that the term wound is to be broadly construed and encompasses open and closed wounds in which skin is torn, cut or punctured or where trauma causes a contusion, or any other superficial or other conditions or

imperfections on the skin of a patient or otherwise that benefit from reduced pressure treatment. A wound is thus broadly defined as any damaged region of tissue where fluid may or may not be produced. Examples of such wounds include, but are not limited to, abdominal wounds or other large or incisional wounds, either as a result of surgery, trauma, sterniotomies, fasciotomies, or other conditions, dehisced wounds, acute wounds, chronic wounds, subacute and dehisced wounds, traumatic wounds, flaps and skin grafts, lacerations, abrasions, contusions, burns, diabetic ulcers, pressure ulcers, stoma, surgical wounds, trauma and venous ulcers or the like.

[0057] It will be understood that embodiments of the present disclosure are generally applicable to use in topical negative pressure (“TNP”) therapy systems. Briefly, negative pressure wound therapy assists in the closure and healing of many forms of “hard to heal” wounds by reducing tissue oedema; encouraging blood flow and granular tissue formation; removing excess exudate and may reduce bacterial load (and thus infection risk). In addition, the therapy allows for less disturbance of a wound leading to more rapid healing. TNP therapy systems may also assist on the healing of surgically closed wounds by removing fluid and by helping to stabilize the tissue in the apposed position of closure. A further beneficial use of TNP therapy can be found in grafts and flaps where removal of excess fluid is important and close proximity of the graft to tissue is required in order to ensure tissue viability.

[0058] As is used herein, reduced or negative pressure levels, such as $-X$ mmHg, represent pressure levels that are below standard atmospheric pressure, which corresponds to 760 mmHg (or 1 atm, 29.93 inHg, 101.325 kPa, 14.696 psi, etc.). Accordingly, a negative pressure value of $-X$ mmHg reflects absolute pressure that is X mmHg below 760 mmHg or, in other words, an absolute pressure of $(760-X)$ mmHg. In addition, negative pressure that is “less” or “smaller” than X mmHg corresponds to pressure that is closer to atmospheric pressure (e.g., -40 mmHg is less than -60 mmHg). Negative pressure that is “more” or “greater” than $-X$ mmHg corresponds to pressure that is further from atmospheric pressure (e.g., -80 mmHg is more than -60 mmHg).

[0059] The negative pressure range for some embodiments of the present disclosure can be approximately -80 mmHg, or between about -20 mmHg and -200 mmHg. Note that these pressures are relative to normal ambient atmospheric pressure. Thus, -200 mmHg would be about 560 mmHg in practical terms. In some embodiments, the pressure range can be between about -40 mmHg and -150 mmHg. Alternatively a

pressure range of up to -75 mmHg, up to -80 mmHg or over -80 mmHg can be used. Also in other embodiments a pressure range of below -75 mmHg can be used. Alternatively, a pressure range of over approximately -100 mmHg, or even 150 mmHg, can be supplied by the negative pressure apparatus. In some embodiments of wound closure devices described here, increased wound contraction can lead to increased tissue expansion in the surrounding wound tissue. This effect may be increased by varying the force applied to the tissue, for example by varying the negative pressure applied to the wound over time, possibly in conjunction with increased tensile forces applied to the wound via embodiments of the wound closure devices. In some embodiments, negative pressure may be varied over time for example using a sinusoidal wave, square wave, and/or in synchronization with one or more patient physiological indices (e.g., heartbeat). Examples of such applications where additional disclosure relating to the preceding may be found include Application Serial No. 11/919,355, titled "Wound treatment apparatus and method," filed October 26, 2007, published as US 2009/0306609; and U.S. Patent No. 7,753,894, titled "Wound cleansing apparatus with stress," issued July 13, 2010. Both applications are hereby incorporated by reference in their entirety.

[0060] Appendix 1 is a disclosure hereby incorporated by reference and considered to be part of this specification which contains embodiments that may be used in combination or in addition to the embodiments described herein.

[0061] Appendix 2 is another application hereby incorporated by reference and considered to be part of this specification which contains embodiments that may be used in combination or in addition to the embodiments described herein.

[0062] International Application PCT/GB2012/000587, titled "WOUND DRESSING AND METHOD OF TREATMENT" and filed on July 12, 2012, and published as WO 2013/007973 A2 on January 17, 2013, is an application, hereby incorporated and considered to be part of this specification, that is directed to embodiments, methods of manufacture, and wound dressing components and wound treatment apparatuses that may be used in combination or in addition to the embodiments described herein. Additionally, embodiments of the wound dressings, wound treatment apparatuses and methods described herein may also be used in combination or in addition to those described in U.S. Provisional Application Serial No. 61/678,569, filed August 1, 2012, titled "WOUND DRESSING AND METHOD OF TREATMENT," U.S. Provisional Application Serial No. 61/650,904, filed May 23, 2012, titled

“APPARATUSES AND METHODS FOR NEGATIVE PRESSURE WOUND THERAPY,” U.S. Provisional Application Serial No. 61,753,374, filed January 16, 2013, titled “WOUND DRESSING AND METHOD OF TREATMENT,” and U.S. Provisional Application Serial No. 61/753,878 , filed January 17, 2013, titled “WOUND DRESSING AND METHOD OF TREATMENT,” which are hereby incorporated by reference into this present application in their entireties. Embodiments of the wound dressings, wound treatment apparatuses and methods described herein may also be used in combination or in addition to those described in Application Serial No. 13/092,042, filed April 21, 2011, published as US2011/0282309, titled “WOUND DRESSING AND METHOD OF USE,” and which is hereby incorporated by reference in its entirety, including further details relating to embodiments of wound dressings, the wound dressing components and principles, and the materials used for the wound dressings.

[0063] Figure 1 illustrates an embodiment of a TNP wound treatment system 100 comprising a wound dressing 110 in combination with a pump 150. As stated above, the wound dressing 110 can be any wound dressing embodiment disclosed herein including without limitation dressing embodiment or have any combination of features of any number of wound dressing embodiments disclosed herein. Here, the dressing 110 may be placed over a wound as described previously, and a conduit 130 may then be connected to the port 120, although in some embodiments the dressing 101 may be provided with at least a portion of the conduit 130 preattached to the port 120. Preferably, the dressing 110 is provided as a single article with all wound dressing elements (including the port 120) pre-attached and integrated into a single unit. The wound dressing 110 may then be connected, via the conduit 130, to a source of negative pressure such as the pump 150. The pump 150 can be miniaturized and portable, although larger conventional pumps may also be used with the dressing 110 . In some embodiments, the pump 150 may be attached or mounted onto or adjacent the dressing 110 . A connector 140 may also be provided so as to permit the conduit 130 leading to the wound dressing 110 to be disconnected from the pump, which may be useful for example during dressing changes.

[0064] Figures 2A-D illustrate the use of an embodiment of a TNP wound treatment system being used to treat a wound site on a patient. Figure 2A shows a wound site 200 being cleaned and prepared for treatment. Here, the healthy skin surrounding the wound site 200 is preferably cleaned and excess hair removed or shaved. The wound site

200 may also be irrigated with sterile saline solution if necessary. Optionally, a skin protectant may be applied to the skin surrounding the wound site 200. If necessary, a wound packing material, such as foam or gauze, may be placed in the wound site 200. This may be preferable if the wound site 200 is a deeper wound.

[0065] After the skin surrounding the wound site 200 is dry, and with reference now to Figure 2B, the wound dressing 110 may be positioned and placed over the wound site 200. Preferably, the wound dressing 110 is placed with the wound contact layer 2102 over and/or in contact with the wound site 200. In some embodiments, an adhesive layer is provided on the lower surface 2101 of the wound contact layer 2102, which may in some cases be protected by an optional release layer to be removed prior to placement of the wound dressing 110 over the wound site 200. Preferably, the dressing 110 is positioned such that the port 2150 is in a raised position with respect to the remainder of the dressing 110 so as to avoid fluid pooling around the port. In some embodiments, the dressing 110 is positioned so that the port 2150 is not directly overlying the wound, and is level with or at a higher point than the wound. To help ensure adequate sealing for TNP, the edges of the dressing 110 are preferably smoothed over to avoid creases or folds.

[0066] With reference now to Figure 2C, the dressing 110 is connected to the pump 150. The pump 150 is configured to apply negative pressure to the wound site via the dressing 110, and typically through a conduit. In some embodiments, and as described above in Figure 1, a connector may be used to join the conduit from the dressing 110 to the pump 150. Upon the application of negative pressure with the pump 150, the dressing 110 may, in some embodiments, partially collapse and present a wrinkled appearance as a result of the evacuation of some or all of the air underneath the dressing 110. In some embodiments, the pump 150 may be configured to detect if any leaks are present in the dressing 110, such as at the interface between the dressing 110 and the skin surrounding the wound site 200. Should a leak be found, such leak is preferably remedied prior to continuing treatment.

[0067] Turning to Figure 2D, additional fixation strips 210 may also be attached around the edges of the dressing 110. Such fixation strips 210 may be advantageous in some situations so as to provide additional sealing against the skin of the patient surrounding the wound site 200. For example, the fixation strips 210 may provide additional sealing for when a patient is more mobile. In some cases, the fixation strips

210 may be used prior to activation of the pump 150, particularly if the dressing 110 is placed over a difficult to reach or contoured area.

[0068] Treatment of the wound site 200 preferably continues until the wound has reached a desired level of healing. In some embodiments, it may be desirable to replace the dressing 110 after a certain time period has elapsed, or if the dressing is full of wound fluids. During such changes, the pump 150 may be kept, with just the dressing 110 being changed.

[0069] Figures 3A-C illustrate cross-sections through a wound dressing 2100 similar to the wound dressing of Figure 1 according to an embodiment of the disclosure. A view from above the wound dressing 2100 is illustrated in Figure 1 with the line A-A indicating the location of the cross-section shown in Figures 3A and 3B. The wound dressing 2100, which can alternatively be any wound dressing embodiment disclosed herein including without limitation wound dressing 110 or any combination of features of any number of wound dressing embodiments disclosed herein, can be located over a wound site to be treated. The dressing 2100 may be placed to as to form a sealed cavity over the wound site. In a preferred embodiment, the dressing 2100 comprises a backing layer 2140 attached to a wound contact layer 2102, both of which are described in greater detail below. These two layers 2140, 2102 are preferably joined or sealed together so as to define an interior space or chamber. This interior space or chamber may comprise additional structures that may be adapted to distribute or transmit negative pressure, store wound exudate and other fluids removed from the wound, and other functions which will be explained in greater detail below. Examples of such structures, described below, include a transmission layer 2105 and an absorbent layer 2110.

[0070] As illustrated in Figures 3A-C, a lower surface 2101 of the wound dressing 2100 may be provided with an optional wound contact layer 2102. The wound contact layer 2102 can be a polyurethane layer or polyethylene layer or other flexible layer which is perforated, for example via a hot pin process, laser ablation process, ultrasound process or in some other way or otherwise made permeable to liquid and gas. The wound contact layer 2102 has a lower surface 2101 and an upper surface 2103. The perforations 2104 preferably comprise through holes in the wound contact layer 2102 which enable fluid to flow through the layer 2102. The wound contact layer 2102 helps prevent tissue ingrowth into the other material of the wound dressing. Preferably, the perforations are small enough to meet this requirement while still allowing fluid to flow therethrough. For

example, perforations formed as slits or holes having a size ranging from 0.025 mm to 1.2 mm are considered small enough to help prevent tissue ingrowth into the wound dressing while allowing wound exudate to flow into the dressing. In some configurations, the wound contact layer 2102 may help maintain the integrity of the entire dressing 2100 while also creating an air tight seal around the absorbent pad in order to maintain negative pressure at the wound.

[0071] Some embodiments of the wound contact layer 2102 may also act as a carrier for an optional lower and upper adhesive layer (not shown). For example, a lower pressure sensitive adhesive may be provided on the lower surface 2101 of the wound dressing 2100 whilst an upper pressure sensitive adhesive layer may be provided on the upper surface 2103 of the wound contact layer. The pressure sensitive adhesive, which may be a silicone, hot melt, hydrocolloid or acrylic based adhesive or other such adhesives, may be formed on both sides or optionally on a selected one or none of the sides of the wound contact layer. When a lower pressure sensitive adhesive layer is utilized may be helpful to adhere the wound dressing 2100 to the skin around a wound site. In some embodiments, the wound contact layer may comprise perforated polyurethane film. The lower surface of the film may be provided with a silicone pressure sensitive adhesive and the upper surface may be provided with an acrylic pressure sensitive adhesive, which may help the dressing maintain its integrity. In some embodiments, a polyurethane film layer may be provided with an adhesive layer on both its upper surface and lower surface, and all three layers may be perforated together.

[0072] A layer 2105 of porous material can be located above the wound contact layer 2102. This porous layer, or transmission layer, 2105 allows transmission of fluid including liquid and gas away from a wound site into upper layers of the wound dressing. In particular, the transmission layer 2105 preferably ensures that an open air channel can be maintained to communicate negative pressure over the wound area even when the absorbent layer has absorbed substantial amounts of exudates. The layer 2105 should preferably remain open under the typical pressures that will be applied during negative pressure wound therapy as described above, so that the whole wound site sees an equalized negative pressure. The layer 2105 may be formed of a material having a three dimensional structure. For example, a knitted or woven spacer fabric (for example Baltex 7970 weft knitted polyester) or a non-woven fabric could be used.

[0073] A layer 2110 of absorbent material is provided above the transmission layer 2105. The absorbent material, which comprise a foam or non-woven natural or synthetic material, and which may optionally comprise a super-absorbent material, forms a reservoir for fluid, particularly liquid, removed from the wound site. In some embodiments, the layer 2100 may also aid in drawing fluids towards the backing layer 2140.

[0074] With reference to Figures 3A-C, a masking or obscuring layer 2107 can be positioned beneath at least a portion of the backing layer 2140. In some embodiments, the obscuring layer 2107 can have any of the same features, materials, or other details of any of the other embodiments of the obscuring layers disclosed herein, including but not limited to having any viewing windows or holes. Additionally, the obscuring layer 2107 can be positioned adjacent to the backing layer, or can be positioned adjacent to any other dressing layer desired. In some embodiments, the obscuring layer 2107 can be adhered to or integrally formed with the backing layer. Preferably, the obscuring layer 2107 is configured to have approximately the same size and shape as the absorbent layer 2110 so as to overlay it. As such, in these embodiments the obscuring layer 2107 will be of a smaller area than the backing layer 2140.

[0075] The material of the absorbent layer 2110 may also prevent liquid collected in the wound dressing 2100 from flowing freely within the dressing, and preferably acts so as to contain any liquid collected within the absorbent layer 2110. The absorbent layer 2110 also helps distribute fluid throughout the layer via a wicking action so that fluid is drawn from the wound site and stored throughout the absorbent layer. This helps prevent agglomeration in areas of the absorbent layer. The capacity of the absorbent material must be sufficient to manage the exudates flow rate of a wound when negative pressure is applied. Since in use the absorbent layer experiences negative pressures the material of the absorbent layer is chosen to absorb liquid under such circumstances. A number of materials exist that are able to absorb liquid when under negative pressure, for example superabsorber material. The absorbent layer 2110 may typically be manufactured from ALLEVYN™ foam, Freudenberg 114-224-4 and/or Chem-Posite™11C-450. In some embodiments, the absorbent layer 2110 may comprise a composite comprising superabsorbent powder, fibrous material such as cellulose, and bonding fibers. In a preferred embodiment, the composite is an airlaid, thermally-bonded composite.

[0076] An orifice 2145 is preferably provided in the backing layer 2140 to allow a negative pressure to be applied to the dressing 2100. A suction port 2150 is preferably attached or sealed to the top of the backing layer 2140 over an orifice 2145 made into the dressing 2100, and communicates negative pressure through the orifice 2145. A length of tubing 2220 may be coupled at a first end to the suction port 2150 and at a second end to a pump unit (not shown) to allow fluids to be pumped out of the dressing. The port may be adhered and sealed to the backing layer 2140 using an adhesive such as an acrylic, cyanoacrylate, epoxy, UV curable or hot melt adhesive. The port 2150 is formed from a soft polymer, for example a polyethylene, a polyvinyl chloride, a silicone or polyurethane having a hardness of 30 to 90 on the Shore A scale. In some embodiments, the port 2150 may be made from a soft or conformable material, for example using the embodiments described below in Figures 23A-B.

[0077] Preferably the absorbent layer 2110 and the obscuring layer 2107 include at least one through hole 2146 located so as to underlie the port 2150. The through hole 2146, while illustrated here as being larger than the hole through the obscuring layer 2107 and backing layer 2140, may in some embodiments be bigger or smaller than either. Of course, the respective holes through these various layers 2107, 2140, and 2110 may be of different sizes with respect to each other. As illustrated in Figures 3A-C a single through hole can be used to produce an opening underlying the port 2150. It will be appreciated that multiple openings could alternatively be utilized. Additionally should more than one port be utilized according to certain embodiments of the present disclosure one or multiple openings may be made in the absorbent layer and the obscuring layer in registration with each respective port. Although not essential to certain embodiments of the present disclosure the use of through holes in the super-absorbent layer may provide a fluid flow pathway which remains unblocked in particular when the absorbent layer 2100 is near saturation.

[0078] The aperture or through-hole 2146 is preferably provided in the absorbent layer 2110 and the obscuring layer 2107 beneath the orifice 2145 such that the orifice is connected directly to the transmission layer 2105. This allows the negative pressure applied to the port 2150 to be communicated to the transmission layer 2105 without passing through the absorbent layer 2110. This ensures that the negative pressure applied to the wound site is not inhibited by the absorbent layer as it absorbs wound exudates. In other embodiments, no aperture may be provided in the absorbent layer 2110

and/or the obscuring layer 2107, or alternatively a plurality of apertures underlying the orifice 2145 may be provided.

[0079] The backing layer 2140 is preferably gas impermeable, but moisture vapor permeable, and can extend across the width of the wound dressing 2100. The backing layer 2140, which may for example be a polyurethane film (for example, Elastollan SP9109) having a pressure sensitive adhesive on one side, is impermeable to gas and this layer thus operates to cover the wound and to seal a wound cavity over which the wound dressing is placed. In this way an effective chamber is made between the backing layer 2140 and a wound site where a negative pressure can be established. The backing layer 2140 is preferably sealed to the wound contact layer 2102 in a border region 2200 around the circumference of the dressing, ensuring that no air is drawn in through the border area, for example via adhesive or welding techniques. The backing layer 2140 protects the wound from external bacterial contamination (bacterial barrier) and allows liquid from wound exudates to be transferred through the layer and evaporated from the film outer surface. The backing layer 2140 preferably comprises two layers; a polyurethane film and an adhesive pattern spread onto the film. The polyurethane film is preferably moisture vapor permeable and may be manufactured from a material that has an increased water transmission rate when wet.

[0080] The absorbent layer 2110 may be of a greater area than the transmission layer 2105, such that the absorbent layer overlaps the edges of the transmission layer 2105, thereby ensuring that the transmission layer does not contact the backing layer 2140. This provides an outer channel 2115 of the absorbent layer 2110 that is in direct contact with the wound contact layer 2102, which aids more rapid absorption of exudates to the absorbent layer. Furthermore, this outer channel 2115 ensures that no liquid is able to pool around the circumference of the wound cavity, which may otherwise seep through the seal around the perimeter of the dressing leading to the formation of leaks.

[0081] As shown in Figure 3A, one embodiment of the wound dressing 2100 comprises an aperture 2146 in the absorbent layer 2110 situated underneath the port 2150. In use, for example when negative pressure is applied to the dressing 2100, a wound facing portion of the port 150 may thus come into contact with the transmission layer 2105, which can thus aid in transmitting negative pressure to the wound site even when the absorbent layer 2110 is filled with wound fluids. Some embodiments may have the

backing layer 2140 be at least partly adhered to the transmission layer 2105. In some embodiments, the aperture 2146 is at least 1-2 mm larger than the diameter of the wound facing portion of the port 2150, or the orifice 2145.

[0082] A filter element 2130 that is impermeable to liquids, but permeable to gases is provided to act as a liquid barrier, and to ensure that no liquids are able to escape from the wound dressing. The filter element may also function as a bacterial barrier. Typically the pore size is 0.2 μ m. Suitable materials for the filter material of the filter element 2130 include 0.2 micron Gore™ expanded PTFE from the MMT range, PALL Versapore™ 200R, and Donaldson™ TX6628. Larger pore sizes can also be used but these may require a secondary filter layer to ensure full bioburden containment. As wound fluid contains lipids it is preferable, though not essential, to use an oleophobic filter membrane for example 1.0 micron MMT-332 prior to 0.2 micron MMT-323. This prevents the lipids from blocking the hydrophobic filter. The filter element can be attached or sealed to the port and/or the backing layer 2140 over the orifice 2145. For example, the filter element 2130 may be molded into the port 2150, or may be adhered to both the top of the backing layer 2140 and bottom of the port 2150 using an adhesive such as, but not limited to, a UV cured adhesive.

[0083] In Figure 3B, an embodiment of the wound dressing 2100 is illustrated which comprises spacer elements 2152, 2153 in conjunction with the port 2150 and the filter 2130. With the addition of such spacer elements 2152, 2153, the port 2150 and filter 2130 may be supported out of direct contact with the absorbent layer 2110 and/or the transmission layer 2105. The absorbent layer 2110 may also act as an additional spacer element to keep the filter 2130 from contacting the transmission layer 2105. Accordingly, with such a configuration contact of the filter 2130 with the transmission layer 2105 and wound fluids during use may thus be minimized. As contrasted with the embodiment illustrated in Figure 3A, the aperture 2146 through the absorbent layer 2110 and the obscuring layer 2107 may not necessarily need to be as large or larger than the port 2150, and would thus only need to be large enough such that an air path can be maintained from the port to the transmission layer 2105 when the absorbent layer 2110 is saturated with wound fluids.

[0084] With reference now to Figure 3C, which shares many of the elements illustrated in Figures 3A-C, the embodiment illustrated here comprises the backing layer 2140, masking layer 2107, and absorbent layer 2110, all of which have a cut or opening

made therethrough which communicate directly to the transmission layer 2105 so as to form the orifice 2145. The suction port 2150 is preferably situated above it and communicates with the orifice 2145.

[0085] In particular for embodiments with a single port 2150 and through hole, it may be preferable for the port 2150 and through hole to be located in an off-center position as illustrated in Figures 3A-C and in Figure 1. Such a location may permit the dressing 2100 to be positioned onto a patient such that the port 2150 is raised in relation to the remainder of the dressing 2100. So positioned, the port 2150 and the filter 2130 may be less likely to come into contact with wound fluids that could prematurely occlude the filter 2130 so as to impair the transmission of negative pressure to the wound site.

[0086] Figures 4A-C illustrate embodiments of wound dressings 300 similar to the embodiments described above and provided with a narrowed central portion in various lengths and widths. Figure 4A illustrates an embodiment of a wound dressing 300 with a narrowed central portion or a waisted middle portion. The wound dressing 300 has a backing layer 301. The backing layer 301 can have a rectangular or square shaped perimeter and can be a transparent or translucent material. The backing layer 301 can have a lower surface 305 and an upper surface 306. The lower surface of the backing layer 301 can be configured to be placed on the skin surface surrounding the wound site as discussed previously with reference to Figures 3A-C. Additionally, the lower surface 305 can have a wound contact layer. The wound contact layer can have all the features and embodiments described herein, including without limitation wound dressing embodiments described in reference to Figures 3A-C. The wound contact layer can be adhered to the perimeter of the lower surface 305 of the backing layer 301. The wound contact layer can comprise an adhesive or any other method of attachment that allows attachment of the wound dressing to the skin surface as previously described.

[0087] In some embodiments, the wound dressing 300 can have a port 304 offset from the center of the dressing as described previously. The port 304 can be a domed port or a soft fluidic connector (described in detail below). Although the port 304 can be placed in a central location on the dressing, it is preferably offset from the center of the dressing to a particular side or edge. As such, the orientation of the port 304, when placed on the body, may thus permit the port 304 to be situated in an elevated position, thereby increasing the amount of time that the dressing 300 may be used before coming into contact with fluids. Although other orientations may be used, and may occur in

practice (e.g., when the patient shifts positions), placing the port 304 at a lower position may cause the filter proximate the port (not illustrated here) to become saturated, which may cause the dressing to need changing even though there may still remain some absorptive capacity within the absorbent layer. Preferably, the port 304 has an orifice for the connection of a tube or conduit thereto; this orifice may be angled away from the center of the dressing 300 so as to permit the tube or conduit to extend away from the dressing 300. In some preferred embodiments, the port 304 comprises an orifice that permits the tube or conduit inserted therein to be approximately parallel to the top surface of the backing layer 301.

[0088] In various embodiments, the wound dressing 300 can have an absorbent material 302. The absorbent material 302 can be accompanied by the additional components within the wound dressing as described with reference to the wound dressing cross-section in Figure 3A-B, such as a transmission layer and a masking or obscuring layer (not shown).

[0089] In some embodiments, the wound dressing 300 can have an absorbent material 302 with a central portion 308. The absorbent material 302 can have a longitudinal length and a transverse width. In some embodiments, the longitudinal length is greater than the transverse width. In some embodiments, the longitudinal length and the transverse width are of equal size. In various embodiments, the absorbent material 302 can have a contoured shape with a substantially rectangular body.

[0090] The central portion 308 of the absorbent material 302 may comprise a waisted portion 303. The waisted portion 303 can be defined by the transverse width of the absorbent material 302 narrowing at the central portion 308 of the longitudinal length. For example, in some embodiments, the waisted portion 303 can be a narrow width at the central portion 308 of the absorbent material 302, as illustrated in Figures 4A-C. Additional embodiments of the waisted portion 303 are possible including those described herein. Further, the shape of the accompanying components within the wound dressing as described with reference to Figures 3A-C can be formed to the same contoured shape of the absorbent material including the waisted portion.

[0091] The waisted portion 303 can increase the flexibility of the wound dressing and can allow enhanced compatibility of the wound dressing to the patient's body. For example, the narrow central region may allow for improved contact and adhesion of the wound dressing to the skin surface when the wound dressing is used on

non-planar surfaces and/or wrapped around an arm or leg. Further, the narrow central portion provides increased compatibility with the patient's body and patient movement.

[0092] As in Figures 15A-B, embodiments of wound dressings may comprise various configurations of slits (described in detail below) so as to further enhance conformability of the dressing in non-planar wounds. Also, as described below, the absorbent layers may be colored or obscured with an obscuring layer, and optionally provided with one or more viewing windows. The domed ports may also be replaced with one or more fluidic connectors of the type described below in Figures 23A-B. Further, the wound dressing 300 can comprise all designs or embodiments herein described or have any combination of features of any number of wound dressing embodiments disclosed herein.

[0093] Figure 4B illustrates an embodiment of a wound dressing 300 with a waisted portion. A wound dressing 300 as illustrated in Figure 4B can have the features and embodiments as described above with reference to Figure 4A. However, Figure 4B illustrates an embodiment with a shorter longitudinal length with respect to the transverse width. Figure 4C illustrates an additional embodiment of a wound dressing 300 with a waisted portion. As illustrated in Figure 4C, the wound dressing can have a longitudinal length and a transverse width that are not substantially different in size, as opposed to a longitudinal length that is substantially longer than the transverse width of the wound dressing as shown in the embodiments illustrated in Figure 4A and 4B. The embodiments of a wound dressing illustrated in Figures 4B and 4C can include all features and embodiments described herein for wound dressings including those embodiments of the waisted portion 303 described with reference to Figure 4A.

[0094] Figures 5A-F, 6A-F, 7A-F, 8A-F, 9A-F, 10A-F, 11A-F, 12A-F, and 24 illustrate additional embodiments of wound dressings. In these embodiments, a waisted portion 408 is located inwardly with reference to an edge 409 of the absorbent layer 402. Preferably, the contour of the absorbent layer 402 is curved from the edge 409 to the waisted portion 408, so as to form a smooth contour.

[0095] Figures 5A-F illustrate multiple views of an embodiment of a wound dressing with a waisted portion, obscuring layer, and viewing windows. Figure 5A illustrates a perspective view of an embodiment of a wound dressing 400. The wound dressing 400 preferably comprises a port 406. The port 406 is preferably configured to be in fluid communication with a pump as described with reference to Figure 1, and may

include a tube or conduit pre-attached to the port. Alternatively, negative pressure can be supplied to the wound dressing through other suitable fluidic connectors, including but not limited to the fluidic connectors of the type described below in Figures 23A-B.

[0096] The wound dressing 400 can be constructed similar to the embodiments of Figures 3A and 3B above, and may comprise an absorbent material 402 underneath or within a backing layer 405. Optionally, a wound contact layer and a transmission layer may also be provided as part of the wound dressing 400 as described above. The absorbent material 402 can contain a narrowed central or waisted portion 408, as described previously to increase flexibility and conformability of the wound dressing to the skin surface. The backing layer 405 may have a border region 401 that extends beyond the periphery of the absorbent material 402. The backing layer 405 may be a translucent or transparent backing layer, such that the border region 401 created from the backing layer 405 can be translucent or transparent. The area of the border region 401 of the backing layer 405 can be approximately equal around the perimeter of the entire dressing with the exception of the narrowed central portion, where the area of the border region is larger. One will recognize that the size of the border region 401 will depend on the full dimensions of the dressing and any other design choices.

[0097] As illustrated in Figure 5A, provided at least at the top of or over the absorbent layer 402 and under the backing layer 405 may be an obscuring layer 404 that optionally has one or more viewing windows 403. The obscuring layer 404 may partially or completely obscure contents (such as fluids) contained within the wound dressing 400 and/or the absorbent material (i.e., within the absorbent material 402 or under the backing layer 405). The obscuring layer may be a colored portion of the absorbent material, or may be a separate layer that covers the absorbent material. In some embodiments, the absorbent material 402 may be hidden (partially or completely), colored, or tinted, via the obscuring layer 404, so as to provide cosmetic and/or aesthetic enhancements, in a similar manner to what is described above. The obscuring layer is preferably provided between the topmost backing layer 405 and the absorbent material 402, although other configurations are possible. The cross-sectional view in Figure 3A and B illustrates this arrangement with respect to the masking or obscuring layer 2107. Other layers and other wound dressing components can be incorporated into the dressing as herein described.

[0098] The obscuring layer 404 can be positioned at least partially over the absorbent material 402. In some embodiments, the obscuring layer 404 can be positioned

adjacent to the backing layer, or can be positioned adjacent to any other dressing layer desired. In some embodiments, the obscuring layer 404 can be adhered to or integrally formed with the backing layer and/or the absorbent material.

[0099] As illustrated in Figure 5A, the obscuring layer 404 can have substantially the same perimeter shape and size as the absorbent material 402. The obscuring layer 404 and absorbent material 402 can be of equal size so that the entirety of the absorbent material 402 can be obscured by the obscuring layer 404. The obscuring layer 404 may allow for obscuring of wound exudate, blood, or other matter released from a wound. Further, the obscuring layer 404 can be completely or partially opaque having cut-out viewing windows or perforations.

[0100] In some embodiments, the obscuring layer 404 can help to reduce the unsightly appearance of a dressing during use, by using materials that impart partial obscuring or masking of the dressing surface. The obscuring layer 404 in one embodiment only partially obscures the dressing, to allow clinicians to access the information they require by observing the spread of exudate across the dressing surface. The partial masking nature of this embodiment of the obscuring layer enables a skilled clinician to perceive a different color caused by exudate, blood, by-products etc. in the dressing allowing for a visual assessment and monitoring of the extent of spread across the dressing. However, since the change in color of the dressing from its clean state to a state containing exudate is only a slight change, the patient is unlikely to notice any aesthetic difference. Reducing or eliminating a visual indicator of wound exudate from a patient's wound is likely to have a positive effect on their health, reducing stress for example.

[0101] In some embodiments, the obscuring layer can be formed from a non-woven fabric (for example, polypropylene), and may be thermally bonded using a diamond pattern with 19% bond area. In various embodiments, the obscuring layer can be hydrophobic or hydrophilic. Depending on the application, in some embodiments, a hydrophilic obscuring layer may provide added moisture vapor permeability. In some embodiments, however, hydrophobic obscuring layers may still provide sufficient moisture vapor permeability (i.e., through appropriate material selection, thickness of the obscuring layer), while also permitting better retention of dye or color in the obscuring layer. As such, dye or color may be trapped beneath the obscuring layer. In some embodiments, this may permit the obscuring layer to be colored in lighter colors or in

white. In the preferred embodiment, the obscuring layer is hydrophobic. In some embodiments, the obscuring layer material can be sterilizable using ethylene oxide. Other embodiments may be sterilized using gamma irradiation, an electron beam, steam or other alternative sterilization methods. Additionally, in various embodiments the obscuring layer can be colored or pigmented, e.g., in medical blue. The obscuring layer may also be constructed from multiple layers, including a colored layer laminated or fused to a stronger uncolored layer. Preferably, the obscuring layer is odorless and exhibits minimal shedding of fibers.

[0102] The absorbent layer 402, itself may be colored or tinted in some embodiments, however, so that an obscuring layer is not necessary. The dressing may optionally include a means of partially obscuring the top surface. This could also be achieved using a textile (knitted, woven, or non-woven) layer without openings, provided it still enables fluid evaporation from the absorbent structure. It could also be achieved by printing an obscuring pattern on the top film, or on the top surface of the uppermost pad component, using an appropriate ink or colored pad component (yarn, thread, coating) respectively. Another way of achieving this would be to have a completely opaque top surface, which could be temporarily opened by the clinician for inspection of the dressing state (for example through a window), and closed again without compromising the environment of the wound.

[0103] Additionally, Figure 5A illustrates an embodiment of the wound dressing including one or more viewing windows 403. The one or more viewing windows 403 preferably extend through the obscuring layer 404. These viewing windows 403 may allow visualization by a clinician or patient of the wound exudate in the absorbent material below the obscuring layer. Figure 5A illustrates an array of dots (e.g., in one or more parallel rows) that can serve as viewing windows 403 in the obscuring layer 404 of the wound dressing. In a preferred embodiment, two or more viewing windows 403 may be parallel with one or more sides of the dressing 400. In some embodiments, the one or more viewing windows may measure between 0.1 mm and 20 mm, preferably 0.4 mm to 10 mm, and even more preferably, 1mm to 4 mm.

[0104] The viewing windows 403 may be cut through the obscuring layer 404 or may be part of an uncolored area of the obscuring layer 404 and therefore may allow visualization of the absorbent material 402. The one or more viewing windows 403 can be arranged in a repeating pattern across the obscuring layer 404 or can be arranged at

random across the obscuring layer. Additionally, the one or more viewing windows can be a circular shape or dots. Preferably, the one or more viewing windows 403 are configured so as to permit not only the degree of saturation, but also the progression or spread of fluid toward the fluid port 406, as in some embodiments, dressing performance may be adversely affected when the level of fluid has saturated the fluid proximate the port 406. In some embodiments, a “starburst” array of viewing windows 403 emanating around the port 406 may be suitable to show this progression, although of course other configurations are possible.

[0105] In Figure 5A, the viewing windows 403 correspond to the area of the absorbent material 402 that is not covered by the obscuring layer 404. As such, the absorbent material 402 is directly adjacent the backing layer 405 in this area. Since the obscuring layer 404 acts as a partial obscuring layer, the viewing windows 403 may be used by a clinician or other trained user to assess the spread of wound exudate throughout the dressing. In some embodiments, the viewing windows 403 can comprise an array of dots or crescent shaped cut-outs. For example, an array of dots as viewing windows 403 are illustrated in Figures 5A-F, 6A-F, 7A-F, 8A-F, 9A-F, 10A-F, 11A-F, and 12A-F in which the array of dots are arranged in an 5 x 2, 3 x 2, 8 x 1, 5 x 1, 3 x 1, 3 x 3, 3 x 3, and quincunx array respectively. Additionally, in some embodiments, the dot pattern can be distributed evenly throughout the obscuring layer and across the entire or substantially the entire surface of the obscuring layer. In some embodiments, the viewing windows 403 may be distributed randomly throughout the obscuring layer. Preferably, the area of the obscuring layer 404 uncovered by the one or more viewing windows 403 is balanced to as to minimize the appearance of exudate while permitting the inspection of the dressing 400 and/or absorbent material 402. In some embodiments, the area exposed by the one or more viewing windows 403 does not exceed 20% of the area of the obscuring layer 404, preferably 10%, and even more preferably 5%.

[0106] The viewing windows 403 may take several configurations, as will be discussed in relation to Figures 16-18. In Figure 17, the viewing windows 403 may comprise an array of regularly spaced uncolored dots (holes) made into the obscuring layer 404. While the dots illustrated here are in a particular pattern, the dots may be arranged in different configurations, or at random. The viewing windows 403 are preferably configured so as to permit a patient or caregiver to ascertain the status of the absorbent layer, in particular to determine its saturation level, as well as the color of the

exudate (e.g., whether excessive blood is present). By having one or more viewing windows, the status of the absorbent layer can be determined in an unobtrusive manner that is not aesthetically displeasing to a patient. Because a large portion of the absorbent layer may be obscured, the total amount of exudate may therefore be hidden. As such, the status and saturation level of the absorbent layer 402 may therefore present a more discreet external appearance so as to reduce patient embarrassment and visibility and thereby enhance patient comfort. In some configurations, the one or more viewing windows 403 may be used to provide a numerical assessment of the degree of saturation of the dressing 400. This may be done electronically (e.g., via a digital photograph assessment), or manually. For example, the degree of saturation may be monitored by counting the number of viewing windows 403 which may be obscured or tinted by exudate or other wound fluids.

[0107] In some embodiments, the absorbent layer 402 or the obscuring layer 404, in particular the colored portion of the absorbent layer, may comprise (or be colored because of) the presence of an auxiliary compound. The auxiliary compound may in some embodiments be activated charcoal, which can act to absorb odors. The use of antimicrobial, antifungal, anti-inflammatory, and other such therapeutic compounds is also possible. In some embodiments, the color may change as a function of time (e.g., to indicate when the dressing needs to be changed), if the dressing is saturated, or if the dressing has absorbed a certain amount of a harmful substance (e.g., to indicate the presence of infectious agents). In some embodiments, the one or more viewing windows 403 may be monitored electronically, and may be used in conjunction with a computer program or system to alert a patient or physician to the saturation level of the dressing 400.

[0108] Figure 16 illustrates an embodiment of a dressing containing a viewing window in the shape of a trademarked brand name (“PICO”). Figure 18 illustrates an embodiment of a dressing comprising a viewing window in the shape of a logo, here, the Smith & Nephew logo. Of course, many other configurations are possible, including other graphics, texts, or designs. The graphical or textual elements present in the viewing window may also be, for example, instructional in nature.

[0109] In other alternatives, instructions may be given to change the wound dressing when the exudate reaches a predetermined distance from the edge of the wound dressing, such as 5 mm from the wound dressing edge or 7 mm from the wound dressing

edge, etc. Alternatively a ‘traffic light’ system may be implemented whereby an electronic indicator shows green, amber or red light to indicate the spread of exudate in the wound dressing. Alternatively or additionally, another suitable indicator may be used for indicating the spread of exudate over the dressing.

[0110] Figures 5A-F illustrate multiple views of the wound dressing 400. Figure 5A illustrates a perspective view of a wound dressing with the dimensions of 300mm x 150mm. Figures 5B and 5C illustrate a top view and bottom view of the embodiment of a wound dressing described in Figure 5A. Figures 5D and 5E illustrate a front and back view respectively of the wound dressing 400 described in Figure 5A. Figure 5F illustrates a side view of the wound dressing as described in Figure 5A.

[0111] Embodiments of the wound dressings described herein may be arranged such that each embodiment may have enhanced compatibility with body movement. This can be achieved by using a different shape for different wound types or areas of the body. Wound dressing embodiments can be of any suitable shape or form or size as illustrated in Figures 5A-F, 6A-F, 7A-F, 8A-F, 9A-F, 10A-F, 11A-F, 12A-F, and 24A-F. The overall dimensions of the dressings as illustrated in Figures 5A-F, 6A-F, 7A-F, 8A-F, 9A-F, 10A-F, 11A-F, 12A-F may be, for example but without limitation, 300 mm x 150 mm, 200mm x 150 mm, 400 mm x 100 mm, 300 mm x 100 mm, 200mm x 100 mm, 250 mm x 250 mm, 200mm x 200mm, and 150 mm x 150mm, respectively, although any total size may be used, and the size may be determined to match particular wound sizes. The oval-shaped dressing in Figures 24A-F may, in some embodiments, measure 190mm x 230mm, or 145.5mm x 190 mm. Again, it will be understood that the embodiments described in the foregoing are simply illustrative embodiments illustrating possible sizes, dimensions, and configurations of wound dressings, and that other configurations are possible.

[0112] As noted above, the preceding embodiments illustrated in Figures 5A-F, 6A-F, 7A-F, 8A-F, 9A-F, 10A-F, 11A-F and 12A-F may comprise a waisted portion 408 located inwardly with reference to an edge 409 of the absorbent layer 402. The contour of the absorbent layer to the waisted portion 408 is preferably rounded and smooth. In the embodiments of Figures 5A-F, 6A-F, 7A-F, 8A-F, and 9A-F, the inward distance between the edge 409 and the waisted portion 408 may range from 1mm, 5mm, 10mm, 15mm, 20mm, and 30mm. Preferably, the inward distance is 10mm. In the embodiments of Figures 10A-F, 11A-F, and 12A-F the inward distance between the edge

409 and the waisted portion 408 may range from 5mm, 10mm, 20mm, 30mm, 40mm, 45mm, 50mm, 60mm, and 75mm. Figures 6A-F illustrate a perspective view, a top view, a bottom view, a front view, a back view, and a side view, respectively, of an embodiment of a wound dressing 400. In some embodiments, the dressing may measure 200mm x 150mm. The wound dressing 400 of Figures 6A-F can have a similar configuration and components as described above for Figures 5A-F, except the embodiments of Figure 6A-F are of a smaller size. Additionally, in contrast to the embodiment of Figures 5A-F which comprises a 5 x 2 configuration of an array of dots viewing windows, the embodiment of Figures 6A-F comprises a viewing window configuration comprising a 3 x 2 array of dots.

[0113] Figures 7A-F illustrate a perspective view, a top view, a bottom view, a front view, a back view, and a side view, respectively, of an embodiment of a wound dressing 400. In some embodiments, the dressing may measure 400mm x 100mm. The wound dressing 400 of Figures 7A-F can have a similar configuration and components as described above for Figures 5A-F, except the embodiments of Figure 7A-F are of a different size. Additionally, in contrast to the embodiment of Figures 5A-F, the embodiment of Figures 7A-F comprises a viewing window configuration comprising an 8 x 1 array of dots.

[0114] Figures 8A-F illustrate a perspective view, a top view, a bottom view, a front view, a back view, and a side view, respectively, of an embodiment of a wound dressing 400. In some embodiments, the dressing may measure 300mm x 100mm. The wound dressing 400 of Figures 8A-F can have a similar configuration and components as described above for Figures 5A-F, except the embodiments of Figure 8A-F are of a different size. Additionally, in contrast to the embodiment of Figures 5A-F, the embodiment of Figures 8A-F comprises a viewing window configuration comprising a 5 x 1 array of dots.

[0115] Figures 9A-F illustrate a perspective view, a top view, a bottom view, a front view, a back view, and a side view, respectively, of an embodiment of a wound dressing 400. In some embodiments, the dressing may measure 200mm x 100mm. The wound dressing 400 of Figures 9A-F can have a similar configuration and components as described above for Figures 5A-F, except the embodiments of Figure 9A-F are of a different size. Additionally, in contrast to the embodiment of Figures 5A-F, the embodiment of Figures 9A-F comprises a viewing window configuration comprising a 3 x 1 array of dots.

[0116] Figures 12A-F illustrate a perspective view, a top view, a bottom view, a front view, a back view, and a side view, respectively, of an embodiment of a wound dressing 400. In some embodiments, the dressing may measure 150mm x 150mm. The wound dressing 400 of Figures 12A-F can have a similar configuration and components as described above for Figures 5A-F, except the embodiments of Figure 9A-F are of a different size. Additionally, in contrast to the embodiment of Figures 5A-F, the embodiment of Figures 12A-F comprises a viewing window configuration comprising a quincunx array of dots. The quincunx array of dots configuration consists of five dots arranged in a cross, with four of the dots forming a square or rectangle where one dot is positioned at each of the four corners of the square or rectangle shaped wound dressing and a fifth dot in the center. However, one corner of the wound dressing preferably has the fluidic connector or port 406 in place of a dot in the quincunx dot array.

[0117] Figures 10A-F illustrate a perspective view, a top view, a bottom view, a front view, a back view, and a side view, respectively, of an embodiment of a wound dressing 400. In some embodiments, the dressing may measure 250mm x 250mm. The wound dressing 400 of Figures 10A-F can have a similar configuration and components as described above for Figures 5A-F, except the embodiments of Figure 10A-F are of a different size. Additionally, in contrast to the embodiment of Figures 5A-F, the embodiment of Figures 10A-F comprises a viewing window configuration comprising a 3 x 3 array of dots with an absent dot at a corner position of the wound dressing and in its place is a domed port or a fluidic connector 406 completing the 3 x 3 array.

[0118] Figures 11A-F illustrate a perspective view, a top view, a bottom view, a front view, a back view, and a side view, respectively, of an embodiment of a wound dressing 400. In some embodiments, the dressing may measure 200mm x 200mm. The wound dressing 400 of Figures 11A-F can have a similar configuration and components as described above for Figures 5A-F, except the embodiments of Figure 11A-F are of a different size. Additionally, in contrast to the embodiment of Figures 5A-F, the embodiment of Figures 11A-F comprises a viewing window configuration comprising a 3 x 3 array of dots with an absent dot at a corner position of the wound dressing and in its place is a domed port or a fluidic connector completing the 3 x 3 array.

[0119] The additional sizes and shapes illustrated in Figures 5A-F, 6A-F, 7A-F, 8A-F, 9A-F, 10A-F, 11A-F, 12A-F, and 24 may incorporate the waisted portion 408,

obscuring layer 404, viewing windows 403, and other components and embodiments described herein.

[0120] Figures 13A, 13B, and 14 illustrate embodiments of a dressing 500 comprising one or more orifice viewing windows 502 at, near, or adjacent to the port. The orifice viewing windows 502 can be provided at, near, adjacent to the port 504 in the backing layer for viewing of the absorbent material 503 present in proximity to the port 504. The orifice viewing windows 502 can have the same structure and/or function as the viewing windows herein described. In some embodiments, the orifice viewing window 502 can be formed from a cross-shaped or Maltese-cross-shaped aperture or cut-out 501 in the obscuring layer. The arms of the cross-shaped cut-out 501 can be aligned with the longitudinal length and transverse width of the absorbent material 503 as shown in Figure 13A. Alternatively, the arms of the cross-shaped cut-out 501 can be offset from the longitudinal length and transverse width of the absorbent material, at an angle, for example, a 45° angle, as illustrated in Figure 13B. The arms of the cross-shaped cut-out may span a larger dimension than a hole in the absorbent material below the cut-out 501. For example, the arms may span a dimension of about 25 mm, while the through-hole in the absorbent material may have a diameter of 10 mm.

[0121] Additionally, Figure 14 illustrates an embodiment of a wound dressing 600 in which the arms of the cross-shaped aperture can have flared edges 601. The orifice viewing windows 502 at, near, or adjacent to the port 604 may be used to indicate that fluid is approaching the port 604 or that the dressing 600 is otherwise becoming saturated. This can assist the clinician or patient in maintaining the wound dressing and determining when to change the dressing, because once fluid contacts the center of the port, such fluid contact may at least partially occlude the hydrophobic filter that may be contained therein so as to interrupt or at least partially block the application of negative pressure. The orifice viewing windows 502 can be used with the fluidic connector as well as the domed port or any other suitable connector.

[0122] As with Figures 15A and 15B, the wound dressing may also be provided with one or more slits 2150 to aid the dressing in conforming to a non-planar area. Figure 15A illustrates an embodiment of a wound dressing 2100 with a narrowed central portion or waisted portion 2120 and concentric slits 2150. This embodiment may be useful for the treatment of wounds on non-planar surfaces or otherwise contoured wounds, including, for example, feet, knees, sacral regions, or other such areas. In some

embodiments, the wound dressing 2100 may provide for one or more slits 2150 cut into the dressing, preferably into the absorbent layer, that may enhance the conformability of the dressing. In this embodiment, the slits 2150 are cut in concentric ovoid arcs, although other configurations (as discussed below) are possible. Preferably, the area under the port 2130 or fluidic connector disposed at the top of the device is free from the slits 2150, as this may interfere with fluid transfer from the dressing. In some embodiments, the slits 2150 may be formed as part of, in addition to, or instead of baffles that may be present within the absorbent layer so as to may aid in distribution of wound exudate. In these embodiments, and with all other embodiments described herein, although a domed connector is shown attached to the dressing, this may be interchanged with any other suitable connector, including for example embodiments of the fluidic connectors described in Figures 23A and 23B (as described below).

[0123] Figure 15B illustrates an embodiment of a wound dressing 2100 with a narrow central portion 2120. Here, however, one or more slits 2150 extending across the width of the dressing may be present. Preferably, these slits 2150 do not extend entirely across the width of the dressing, in order to promote fluid transfer within the absorbent layer. The slits 2150 may enhance conformability of the dressing, possibly in conjunction with the waisted configuration of the dressing, when applied to a non-planar or contoured wound area. For example, such a dressing 2100 may be useful when applied so as to wrap around an arm or a leg.

[0124] Figures 23A and 23B illustrate embodiments of white and black fluidic connectors 2410, 2420, respectively, that may be used to connect an embodiment of a wound dressing described herein to a source of negative pressure. In some embodiments, the domed port used in other embodiments discussed herein (e.g., as illustrated above in Figure 1) may be replaced by the fluidic connector 2410, 2420, for example as illustrated in Figures 16-19. The fluidic connector 2410, 2420 may be flexible and/or enhance the comfort of the patient. The fluidic connector 2410, 2420 preferably comprises a fluidic connector body configured to transmit fluid through itself, including, for example, negative pressure and/or wound exudate. The fluidic connector body is preferably encapsulated within one or more layers of fluid-impermeable material. In some embodiments, the fluid-impermeable material is heat-sealed together to enclose the fluid connector body.

[0125] With reference now to Figure 23A, the body of the fluidic connector 2410 is preferably be constructed from a material configured to transmit fluids therethrough, including fabrics such as 3D fabric. In some embodiments, the thickness of the fluidic connector body may measure between 0.5 to 4mm, preferably 0.7 to 3mm, and even more preferably between 1 and 2mm; in a preferred embodiment the fluid connector body is 1.5mm thick. Suitable materials that may be used for the fluidic connector body, including the 3D fabric, are disclosed in U.S. Application 13/381,885, filed December 30, 2011, published as US2012/0116334, titled “APPARATUSES AND METHODS FOR NEGATIVE PRESSURE WOUND THERAPY,” and which is hereby incorporated by reference in its entirety. Use of the 3D fabric in the fluidic connector body may help alleviate fluid blockage when the connector is kinked, and may further provide for a soft fluidic connector that alleviates contact pressure onto a patient, for example when the patient’s weight is pressed against the fluidic connector. This may enhance patient comfort and reduce the likelihood of pressure ulcers.

[0126] Testing of various weights in various configurations on embodiments of fluidic connectors comprising a 3D fabric was completed. The testing included weights above those believed to be likely to be encountered by a patient, as maximal pressure on a heel for a patient using dressings was found to be 1.3 kg/cm² in some studies. Preferably, embodiments of the fluidic connectors described herein, especially when comprising 3D fabric, can transmit therapeutic levels of negative pressure (i.e., in an amount sufficient to heal a wound) while a weight is pressed down thereupon. For example, embodiments are preferably able to transmit therapeutic levels of negative pressure while an external pressure applied on the dressing and/or 3D fabric of up to 1 kg/cm², preferably up to 2 kg/cm², and even more preferably up to 4 kg/cm². Certain embodiments, as described below, have been tested as being capable of transmitting therapeutic levels of negative pressure while an external pressure applied on the dressing and/or 3D fabric is above 6 kg/cm².

[0127] In the testing, a 400ml wound cavity was used, and pressure was measured both at the wound and at the pump. Embodiments of a fluidic connector comprising 3D fabric were tested when laid flat with a weight placed thereupon. Testing indicated that when no pressure was applied to the fluidic connector, the pressure differential between the pressure at the pump and at the cavity was approximately 2 mmHg. Various different weights were applied, ranging between 2 and 12 kg/cm², in 2

kg increments, and the resulting pressure difference was approximately linear, with the pressure difference at 12 kg/cm² being calculated at 33 mmHg, while the pressure difference at 2 kg/cm² being only 16mmHg. The relation between the pressure difference in mmHg was found to equal approximately 4.5 times the applied load in kg/cm². Testing also indicated that the relative pressure difference between the pressure at the pump and the pressure at the wound after five minutes was less than 10 mmHg when measured at the pump for loads under 4 kg/cm², and under 20 mmHg when measured at the wound for loads under 4 kg/cm².

[0128] Testing was also performed with a weight laid on an embodiment of a fluidic connector, while being bent at a 90° angle. Various different weights were applied, ranging between 2 and 12 kg/cm², in 2 kg increments, and the resulting pressure difference was approximately linear, with the pressure difference at 12 kg/cm² being calculated at 51 mmHg, while the pressure difference at 2 kg/cm² being 17 mmHg. The relation between the pressure difference in mmHg was found to equal approximately 8 times the applied load in kg/cm². Testing also indicated that the relative pressure difference between the pressure at the pump and the pressure at the wound after five minutes was approximately 20 mmHg when measured at the pump for loads under 4 kg/cm², and under 30 mmHg when measured at the wound for loads under 4 kg/cm².

[0129] Further testing was performed with a weight laid on an embodiment of a fluidic connector, while being bent at a 180° angle (i.e., folded over itself). Various different weights were applied, ranging between 2 and 12 kg/cm², in 2 kg increments, and the resulting pressure difference was approximately linear, with the pressure difference at 12 kg/cm² being calculated at 76 mmHg, while the pressure difference at 2 kg/cm² being 25 mmHg. The relation between the pressure difference in mmHg was found to equal approximately 10.7 times the applied load in kg/cm². Testing also indicated that the relative pressure difference between the pressure at the pump and the pressure at the wound after five minutes was approximately 20 mmHg when measured at the pump for loads under 4 kg/cm², and under 30 mmHg when measured at the wound for loads under 4 kg/cm².

[0130] Testing was also performed on different widths and thicknesses of 3D fabric that may be used in embodiments of fluidic connectors described herein. In a particular example, the maximum negative pressure that could be applied using 3D fabric measuring 1, 1.25, 1.5, 1.75, and 2 cm in width was found to be between 85 and 92

mmHg, respectively. Upon application of an applied load of 1 kg/cm^2 , however, the maximum negative pressure applied for a 1cm-width embodiment dropped to 75mmHg, while the 1.25 and 1.5 cm-width embodiments were essentially unchanged, exhibiting pressures between 85 and 90 mmHg. Application of a 1 kg/cm^2 weight made the 1 cm-width embodiment maximum negative pressure drop to about 73mmHg, while the 1.25 cm-width embodiment dropped to about 84 mmHg. The 1.5 cm-width embodiment showed a minimal maximum negative pressure change down to approximately 86 mmHg. As tested, the greatest increases in flow rate (as evidenced by the maximal negative pressures applied) were greatest when increasing the width of the 3D fabric from 1 cm to 1.25 cm, and stabilized above 1.5 cm. Similarly, increasing the width of the 3D fabric (i.e., above 1 cm) was found to slightly reduce the amount of time required to pump a wound cavity down to a target negative pressure.

[0131] Further testing with single and double layers of Baltex 3540 3D fabric, either single or double thickness, indicated that while the maximum negative pressure applied using a single thickness fabric dropped from about 88 mmHg with no applied weight to about 73mmHg with a 2 kg/cm^2 weight. However, a double thickness fabric showed minimal change in the maximum amount of negative pressure applied, dropping from 90mmHg with no weight applied to about 87mmHg with an applied load of 2 kg/cm^2 .

[0132] Depending on the particular application, using wider and/or thicker 3D fabric may permit improved air flow, together with greater pressure and kink resistance in some context; this may be useful especially if higher absolute negative pressure need to be applied to the wound. However, the greater kink and pressure resistance may need to be balanced with other concerns such as perceived bulk and size of the fluidic connector, aesthetics, and comfort, which may require use of a thinner 3D fabric.

[0133] In some embodiments, the proximal end 2411 of the fluidic connector 2410 is configured to be connected to a tube or other conduit that is in fluid communication with a source of negative pressure via the fluid connector body, although some embodiments may provide for the fluidic connector 2410 to be directly connectable to a source of negative pressure without needing a conventional tube. The distal end 2412 of the fluidic connector 2410 may be enlarged, and is configured to be attached and/or adhered to a dressing, for example via an aperture in the backing layer of the dressing

and/or in the fluidic connector 2410, so that the fluid connector body is in fluid communication therewith.

[0134] In one configuration and as illustrated in Figure 23A, the distal end 2412 of the fluidic connector 2410 may be convex on one side and flat on the opposite side. As illustrated in Figures 16-18 below, the flat side may be aligned with the edge of the absorbent layer with the convex side extending over the aperture in the backing layer. The fluidic connector 2410 may be provided preattached to the dressing portion, or may be provided in an unattached format so as to be connectable to the dressing portion by the patient or caregiver. The enlarged distal end 2412 may aid in providing a larger area capable of transmitting negative pressure to the dressing, although the distal end may be provided without any enlargement. Although preferred embodiments of the fluidic connector 2410 are used in dressings that contain substantially all wound exudate within the absorbent material, such that the fluidic connector transmits essentially only air, some embodiments of the fluidic connector may be configured so as to transfer exudate in addition to air. In embodiments of the fluidic connector that are configured to transfer essentially only air (while wound exudate remains substantially within the absorbent material), the distal end of the fluidic connector is preferably provided with a filter configured to block fluid transport beyond itself, such as a hydrophobic filter. An example of such a configuration is described in U.S. Provisional Application Serial No. 61/650,904, filed May 23, 2012, titled "APPARATUSES AND METHODS FOR NEGATIVE PRESSURE WOUND THERAPY," and which is hereby incorporated into this present application in its entirety.

[0135] In embodiments of the fluidic connector that are configured to transfer exudate in addition to air, the fluidic connector may be provided with a secondary air leak channel configured to provide a flow of ambient air to the wound site. Preferably, the secondary air leak channel is provided with a filter to prevent contamination of the wound.

[0136] Turning now to Figure 23B, this figure shows an embodiment similar to Figure 23A, but where the fluidic connector 2420 may appear colored, for example as a result of an obscuring layer similar to that previously described. In some embodiments, obscuring coloration may be provided by dyeing the material used in the fluidic connector 2420, for example the 3D fabric that may be used therein. In some embodiments, the obscuring layer may be placed above the 3D fabric, either above or below the fluid-

impermeable material. In some embodiments, the encapsulating fluid-impermeable material may be colored or tinted. Coloring the fluidic connector 2420 (e.g, via the obscuring layer) may enhance the aesthetic appeal of the device, help in disguising or making the device less obtrusive (in particular when the fluidic connector is visible to others), and, when the fluidic connector is used to transfer exudates away from the wound, may hide the presence of the exudates therein.

[0137] In some embodiments, the fluidic connector body may be colored as a result of an auxiliary compound such as activated charcoal. Further, some embodiments may provide for text or images to be printed thereon, for example for instructional or advertising purposes. Such improvements may enhance patient comfort and minimize embarrassment, thereby increasing patient compliance and satisfaction with the device. The obscuring layer in the fluidic connector can have all features described with reference to the obscuring layer of the wound dressing as herein described.

[0138] Figure 17 illustrates an embodiment of a wound dressing 720 that comprises a hexagonal backing layer and a three-lobed configuration for the absorbent material and the obscuring layer. This wound dressing 720, as with several other embodiments described herein, may be advantageously applied to wounds or areas surrounding wounds that are located in non-planar areas. The embodiment illustrated here may be particularly advantageous when applied to protruding body portions, for example elbows and heels.

[0139] Figure 18 illustrates a wound dressing 730 with a three-lobed configuration similar in some respects to the embodiment illustrated in Figure 17. Here, however, the dressing is smaller and comprises more rounded projections. Figures 16-18 illustrate a fluidic connector 721, 731 similar to those described in Figures 23A and 23B attached to the device, with the flat end aligned with the edge of the absorbent material and the convex end extending over an aperture in the backing layer. This fluidic connector may enhance comfort and prevent pressure ulcers or other complications that may result from extended pressure of a conventional tube onto the wound or skin surrounding the wound (as described above). Of course, different connectors may be used, such as the domed port illustrated in Figure 1.

[0140] Figures 19-20 also illustrate additional embodiments of wound dressings 740, 750 with three-lobed configurations for the absorbent material and a hexagonal backing layer. The wound dressing 750 illustrated in Figure 20 is larger where

the lobes of the absorbent material comprises flared ends, while the wound dressing 740 illustrated in Figure 19 is smaller and the absorbent material does not have flared ends. All suitable fluidic connectors or conduits may be used, and the domed port connector of Figure 20 may be used in place of the fluidic connector of Figure 19, and vice versa. As with the preceding embodiments, the absorbent layers may be colored or obscured, and one or more slits may be formed onto the absorbent layers to enhance conformability to non-planar surfaces. It will be appreciated that in the embodiments of Figures 17-20, the number of lobes may be varied, and the backing layer can have other shapes, and is not limited to being hexagonal.

[0141] Additionally, Figures 21A-C and 22 illustrate embodiments of a wound dressing 760, 770, 780, 790 that comprises a four-lobed configuration. Although these embodiments are illustrated without a port or fluidic connector attached thereto, it will of course be understood that such ports and fluidic connectors are envisioned and may be attached in a similar fashion as described previously herein. Figures 21A-C comprise embodiments of a four-lobed wound dressing comprising an obscuring layer and viewing windows extending through the obscuring layer. The viewing windows can be used as discussed above for visualization of wound exudate in the absorbent layer. Examples of such viewing windows are illustrated in Figures 21A and 21B. The dressing 760 shown in Figure 21A includes an obscuring layer 762 and crescent-shaped viewing windows 764 provided in the obscuring layer to extend through the obscuring layer allowing visibility of the dressing therebelow. The dressing 770 of Figure 21B includes an obscuring layer 772 and a number of holes 774 therethrough acting as viewing windows for viewing the state of the dressing therebelow. Figure 21C shows another dressing 780 including an obscuring layer 782 with viewing windows 784. With the dressings 760, 770, 780 the progress of exudate spread over the dressing and towards the edge of the dressing can be monitored.

[0142] Figure 22 illustrates a perspective view of an embodiment of a wound dressing 790 according to an embodiment of the four-lobe configuration. Figure 22 shows a possible four-lobe configuration of a dressing, useful for enhanced compatibility with body movement, where each layer is shaped to reduce the incident angle of the pad edge, and to provide somewhat independently moving sub-sections of the dressing. The dressing border, including the wound contact layer 791 and the backing layer 792 can also comprise slits, provided to further enhance the conformability on application by allowing

the borders to overlap if needed. The wound dressing with a four-lobe configuration, as well as other configurations, are described in detail in International Application PCT/GB2012/000587, titled “WOUND DRESSING AND METHOD OF TREATMENT” and filed on July 12, 2012. which is incorporated by reference herein.

[0143] Additionally, Figures 24A-F illustrate an embodiment of a wound dressing 2300 with an oval shaped absorbent layer 2308 having multiple lobes 2301. Figures 24A-F illustrate, respectively, perspective, top, bottom, left, right, and side views of an embodiment of the dressing 2300. In some embodiments, the absorbent layer 2308 can have six lobes. Preferably, two or more lobes 2301 (e.g., six lobes) are provided on the wound dressing 2300; the lobes 2301, and specifically, the gaps between the lobes 2301, aid the wound dressing 2300 in conforming to nonplanar wounds. For example, it may be advantageous to use the dressing 2300 to conform around joints such as elbows and knees.

[0144] The dressing 2300 can have a rectangular or square shaped backing layer 2302, and in some embodiments, the overall dressing 2300 may measure 190mm x 230mm, or 145.5mm x 190 mm. Preferably, a fluidic connector such as a port 2306 is attached to the dressing 2300, although it will of be recognized that the fluidic connector of Figures 23A-B may be used instead or in addition. Additionally, in some embodiments, the dressing 2300 can have an obscuring layer 2304 and one or more viewing windows 2303 similar to that described for other embodiments herein. Figure 24A illustrates a perspective view of the dressing 2300, while Figure 24B illustrates a top view, 24C a bottom view, and 24D-F represent views of the four sides of the dressing 2300.

[0145] Figure 25 illustrates an embodiment similar in shape and overall configuration to the embodiments illustrated above in Figures 7A-F. Here, however, the dressing 500 comprises an orifice viewing window 502 similar to that described in relation to Figures 13A-B and 14. The orifice viewing window 502 is preferably formed from a cross-shaped or Maltese-cross shaped aperture or cutout 501 in the obscuring layer 506. The backing layer 510 provided over the obscuring layer preferably has an orifice 504 located at the center of the orifice viewing window 502. Reference number 504 can also be considered to designate a port that may be provided in or over the backing layer 510 to provide a connection to a source of negative pressure, for example, a port provided over the orifice in the backing layer as described above. A smaller orifice 505 may be

located in the absorbent layer 503 that is provided below the obscuring layer 506. The dressing 500 may comprise one or more viewing windows 507; here, eight viewing windows 507 are provided in a linear arrangement. The bottom side of the dressing 500 optionally comprises a layer of adhesive, over which a release layer 513 may be placed. Lines 512 illustrate possible locations where breaks in the release liner 513 may be provided.

[0146] In a preferred embodiment, the dressing 500 illustrated here has a longitudinal length of approximately 400 mm, and a transverse width of approximately 100 mm. The central axis of each arm of the cutout 501 of the orifice viewing window 502 is preferably offset from the longitudinal length and transverse width of the absorbent material, at an angle, for example, a 45° angle, as illustrated. The spacing between each arm of the cutout 501 may be, as illustrated here, 72°, although it will of course be recognized that other angles and configurations are possible. Lines 512, indicating possible locations where breaks in the release liner 513 may be provided, can be located, for example, at 80mm, 40±4mm, and 25±4mm from each of the top and bottom edges of the dressing 500. As illustrated, the orifice or port 504 (and cutout 501) are preferably centered on the transverse midline of the dressing 500, and situated approximately 52-55mm from the top edge of the dressing 500. Although the location may be changed, it may be preferable to locate the port 504 near or along a side, edge, or corner of the dressing 500, which is then preferably elevated with respect to the remainder of the dressing. This configuration may extend the life of the dressing, as fluid would be slower in saturating the absorbent layer below or near the orifice or port 504.

[0147] Figure 26 illustrates an embodiment similar in shape and overall configuration to the embodiments illustrated above in Figures 8A-F. Here, however, the dressing 500 comprises an orifice viewing window 502 and cutout 501, with for example five linearly arranged viewing windows 507, among other parts, that are similar to that described above in relation to Figure 25. In a preferred embodiment, the dressing 500 illustrated here has a longitudinal length of approximately 300 mm, and a transverse width of approximately 100 mm. The spacing between each arm of the cutout 501 may be, as illustrated here, 72°, although it will of course be recognized that other angles and configurations are possible. Lines 512, indicating possible locations where breaks in the release liner 513 may be provided, can be located, for example, at 80mm, 40±4mm, and 25±4mm from each of the top and bottom edges of the dressing 500. As illustrated, the

orifice or port 504 (and cutout 501) are preferably centered on the transverse midline of the dressing 500, and situated approximately 52-55mm from the top edge of the dressing 500.

[0148] Figure 27 illustrates an embodiment similar in shape and overall configuration to the embodiments illustrated above in Figures 9A-F. Here, however, the dressing 500 comprises an orifice viewing window 502 and cutout 501, with for example three linearly arranged viewing windows 507, among other parts, that are similar to that described above in relation to Figure 25. In a preferred embodiment, the dressing 500 illustrated here has a longitudinal length of approximately 200 mm, and a transverse width of approximately 100 mm. The spacing between each arm of the cutout 501 may be, as illustrated here, 72°, although it will of course be recognized that other angles and configurations are possible. Lines 512, indicating possible locations where breaks in the release liner 513 may be provided, can be located, for example, at 80mm, 40±4mm, and 25±4mm from each of the top and bottom edges of the dressing 500. As illustrated, the orifice or port 504 (and cutout 501) are preferably centered on the transverse midline of the dressing 500, and situated approximately 52-55mm from the top edge of the dressing 500.

[0149] Figure 28 illustrates an embodiment similar in shape and overall configuration to the embodiments illustrated above in Figures 5A-F. Here, however, the dressing 500 comprises an orifice viewing window 502 and cutout 501, with for example two rows of five linearly arranged viewing windows 507, among other parts, that are similar to that described above in relation to Figure 25. In a preferred embodiment, the dressing 500 illustrated here has a longitudinal length of approximately 300 mm, and a transverse width of approximately 150 mm. The spacing between each arm of the cutout 501 may be, as illustrated here, 72°, although it will of course be recognized that other angles and configurations are possible. Lines 512, indicating possible locations where breaks in the release liner 513 may be provided, can be located, for example, at 80mm, 40±4mm, and 25±4mm from each of the top and bottom edges of the dressing 500. As illustrated, the orifice or port 504 (and cutout 501) are preferably centered on the transverse midline of the dressing 500, and situated approximately 52-55mm from the top edge of the dressing 500.

[0150] Figure 29 illustrates an embodiment similar in shape and overall configuration to the embodiments illustrated above in Figures 6A-F. Here, however, the

dressing 500 comprises an orifice viewing window 502 and cutout 501, with for example two rows of three linearly arranged viewing windows 507, among other parts, that are similar to that described above in relation to Figure 25. In a preferred embodiment, the dressing 500 illustrated here has a longitudinal length of approximately 300 mm, and a transverse width of approximately 100 mm. The spacing between each arm of the cutout 501 may be, as illustrated here, 72°, although it will of course be recognized that other angles and configurations are possible. Lines 512, indicating possible locations where breaks in the release liner 513 may be provided, can be located, for example, at 80mm, 40±4mm, and 25±4mm from each of the top and bottom edges of the dressing 500. As illustrated, the orifice or port 504 (and cutout 501) are preferably centered on the transverse midline of the dressing 500, and situated approximately 52-55mm from the top edge of the dressing 500.

[0151] Figure 30 illustrates an embodiment similar in shape and overall configuration to the embodiments illustrated above in Figures 10A-F. Here, however, the dressing 500 comprises an orifice viewing window 502 and cutout 501, with a 3 x 3 array of viewing windows absent a viewing window at a corner position of the wound dressing, among other parts, that are similar to that described above in relation to Figure 25 but located in a corner of the dressing 500. In a preferred embodiment, the dressing 500 illustrated here is approximately square, with each side measuring approximately 250mm. The spacing between each arm of the cutout 501 may be, as illustrated here, 72°, although it will of course be recognized that other angles and configurations are possible. Lines 512, indicating possible locations where breaks in the release liner 513 may be provided, can be located, for example, at 80mm, 40±4mm, and 25±4mm from each of the top and bottom edges of the dressing 500. As illustrated, the orifice or port 504 (and cutout 501) are preferably centered on a corner of the dressing 500, and situated approximately 52-55mm from the top edge of the dressing 500.

[0152] Figure 31 illustrates an embodiment similar in shape and overall configuration to the embodiments illustrated above in Figures 11A-F. Here, however, the dressing 500 comprises an orifice viewing window 502 and cutout 501, with a 3 x 3 array of viewing windows absent a viewing window at a corner position of the wound dressing, among other parts, that are similar to that described above in relation to Figure 25 but located in a corner of the dressing 500. In a preferred embodiment, the dressing 500 illustrated here is approximately square, with each side measuring approximately 200mm.

The spacing between each arm of the cutout 501 may be, as illustrated here, 72° , although it will of course be recognized that other angles and configurations are possible. Lines 512, indicating possible locations where breaks in the release liner 513 may be provided, can be located, for example, at 80mm, 40 ± 4 mm, and 25 ± 4 mm from each of the top and bottom edges of the dressing 500. As illustrated, the orifice or port 504 (and cutout 501) are preferably centered on a corner of the dressing 500, and situated approximately 52-55mm from the top edge of the dressing 500.

[0153] Figure 32 illustrates an embodiment similar in shape and overall configuration to the embodiments illustrated above in Figures 12A-F. Here, however, the dressing 500 comprises an orifice viewing window 502 and cutout 501, with a quincunx array of viewing windows absent a viewing window at a corner position of the wound dressing, among other parts, that are similar to that described above in relation to Figure 25 but located in a corner of the dressing 500. In a preferred embodiment, the dressing 500 illustrated here is approximately square, with each side measuring approximately 150mm. The spacing between each arm of the cutout 501 may be, as illustrated here, 72° , although it will of course be recognized that other angles and configurations are possible. Lines 512, indicating possible locations where breaks in the release liner 513 may be provided, can be located, for example, at 80mm, 40 ± 4 mm, and 25 ± 4 mm from each of the top and bottom edges of the dressing 500. As illustrated, the port 504 (and cutout 501) are preferably centered on a corner of the dressing 500, and situated approximately 52-55mm from the top edge of the dressing 500.

[0154] Figure 33A-B illustrates an embodiment somewhat similar in shape and overall configuration to the embodiments illustrated above in Figures 24A-F. Here, however, the oval-shaped dressing 500 comprises an orifice viewing window 502 and cutout 501, among other parts, that are similar to that described above in relation to Figure 25. Viewing windows are not shown, but may be provided as in one embodiment as described above. In a preferred embodiment, the dressing 500 illustrated in Figure 33A has a longitudinal length of approximately 250 mm, and a transverse width of approximately 200 mm. The longitudinal length of the absorbent layer 503 (and corresponding obscuring layer, if so provided) measures approximately 200 mm, with a transverse width of approximately 150mm. The embodiment of the dressing 500 illustrated in Figure 33B has a longitudinal length of approximately 200 mm, and a transverse width of approximately 150 mm. The longitudinal length of the absorbent

layer 503 (and corresponding obscuring layer, if so provided) measures approximately 150 mm, with a transverse width of approximately 100 mm. Although no viewing windows 507 are illustrated, it will of course be understood that one or more such windows 507 may be provided on the dressing 500. The spacing between each arm of the cutout 501 may be 72°, although it will of course be recognized that other angles and configurations are possible. As illustrated, the orifice or port 504 (and cutout 501) are preferably centered on the transverse midline of the dressing 500, and situated approximately 52-55mm from the top edge of the dressing 500.

[0155] Figure 34A illustrates an exploded view of a dressing 3400 for use in negative pressure wound therapy. Although this figure illustrates a dressing having one particular shape, the construction of the layers can be applied to any of the embodiments identified above, including Figures 4A-14, 16-22, and 24A-33B. The dressing 3400 comprises a release layer 3480, wound contact layer 3460, a transmission layer 3450, an acquisition distribution layer 3440, an absorbent layer 3430, an obscuring layer 3420, and a backing layer 3410. The dressing 3400 may be connected to a port, such as described below with respect to Figures 35 and 36. At least the wound contact layer 3460, transmission layer 3450, absorbent layer 3430, obscuring layer 3420, and backing layer 3410 may have properties as described with respect to particular embodiments above, such as the embodiments of Figures 3A-22, and 24A-33B, as well as or instead of the properties described below.

[0156] The dressing 3400 may comprise a wound contact layer 3460 for sealing the dressing 3400 to the healthy skin of a patient surrounding a wound area. Certain embodiments of the wound contact layer may comprise three layers: a polyurethane film layer, a lower adhesive layer and an upper adhesive layer. The upper adhesive layer may assist in maintaining the integrity of the dressing 3400, and the lower adhesive layer may be employed for sealing the dressing 3400 to the healthy skin of a patient around a wound site. As described above, in some embodiments with respect to Figures 3A-C, some embodiments of the polyurethane film layer may be perforated. Some embodiments of the polyurethane film layer and upper and lower adhesive layers may be perforated together after the adhesive layers have been applied to the polyurethane film. In some embodiments a pressure sensitive adhesive, which may be a silicone, hot melt, hydrocolloid or acrylic based adhesive or other such adhesives, may be formed on both sides or optionally on a selected one side of the wound contact layer. In certain

embodiments, the upper adhesive layer may comprise an acrylic pressure sensitive adhesive, and the lower adhesive layer may comprise a silicone pressure sensitive adhesive. In other embodiments the wound contact layer 3460 may not be provided with adhesive. In some embodiments, the wound contact layer 3460 may be transparent or translucent. The film layer of the wound contact layer 3460 may define a perimeter with a rectangular or a square shape. A release layer 3480 may be removably attached to the underside of the wound contact layer 3460, for example covering the lower adhesive layer, and may be peeled off using flaps 3481. Some embodiments of the release layer 3480 may have a plurality of flaps extending along the length of the layer 3480.

[0157] Some embodiments of the dressing 3400 may comprise an optional spacer or transmission layer 3450. The transmission layer 3450 may comprise a porous material or 3D fabric configured to allow for the passage of fluids therethrough away from the wound site and into the upper layers of the dressing 3400. In particular, the transmission layer 3450 can ensure that an open air channel can be maintained to communicate negative pressure over the wound area even when the absorbent layer 3430 has absorbed substantial amounts of exudates. The transmission layer 3450 should remain open under the typical pressures that will be applied during negative pressure wound therapy as described above, so that the whole wound site sees an equalized negative pressure.

[0158] Some embodiments of the transmission layer 3450 may be formed of a material having a three dimensional structure. For example, a knitted or woven spacer fabric (for example Baltex 7970 weft knitted polyester) or a non-woven fabric can be used. In some embodiments, the transmission layer 3450 can have a 3D polyester spacer fabric layer. This layer can have a top layer which is a 84/144 textured polyester, and a bottom layer which can be a 100 denier flat polyester and a third layer formed sandwiched between these two layers which is a region defined by a knitted polyester viscose, cellulose or the like monofilament fiber. In use, this differential between filament counts in the spaced apart layers tends to draw liquid away from the wound bed and into a central region of the dressing 3400 where the absorbent layer 3430 helps lock the liquid away or itself wicks the liquid onwards towards the cover layer 3410 where it can be transpired. Other materials can be utilized, and examples of such materials are described in U.S. Patent Pub. No. 2011/0282309, which are hereby incorporated by reference and made part of this disclosure. However, the transmission layer 3450 may be optional, and for

example may be optional in embodiments of the dressing 3400 which comprise the acquisition distribution layer 3440, described below.

[0159] Some embodiments may comprise a wicking or acquisition distribution layer (ADL) 3440 to horizontally wick fluid such as wound exudate as it is absorbed upward through the layers of the dressing 3400. Lateral wicking of fluid may allow maximum distribution of the fluid through the absorbent layer 3430 and may enable the absorbent layer 3430 to reach its full holding capacity. This may advantageously increase moisture vapor permeation and efficient delivery of negative pressure to the wound site. Some embodiments of the ADL 3440 may comprise viscose, polyester, polypropylene, cellulose, or a combination of some or all of these, and the material may be needle-punched. Some embodiments of the ADL 3440 may comprise polyethylene in the range of 40-150 grams per square meter (gsm).

[0160] The dressing 3400 may further comprise an absorbent or superabsorbent layer 3430. The absorbent layer can be manufactured from ALLEVYNTM foam, Freudenberg 114-224-4 and/or Chem-PositeTM11C-450, or any other suitable material. In some embodiments, the absorbent layer 3430 can be a layer of non-woven cellulose fibers having super-absorbent material in the form of dry particles dispersed throughout. Use of the cellulose fibers introduces fast wicking elements which help quickly and evenly distribute liquid taken up by the dressing. The juxtaposition of multiple strand-like fibers leads to strong capillary action in the fibrous pad which helps distribute liquid.

[0161] For example, some embodiments of the absorbent layer 3430 may comprise a layered construction of an upper layer of non-woven cellulose fibers, superabsorbent particles (SAP), and a lower layer of cellulose fibers with 40-80% SAP. In some embodiments, the absorbent layer 3430 may be an air-laid material. Heat fusible fibers can optionally be used to assist in holding the structure of the pad together. Some embodiments may combine cellulose fibers and air-laid materials, and may further comprise up to 60% SAP. Some embodiments may comprise 60% SAP and 40% cellulose. Other embodiments of the absorbent layer may comprise between 60% and 90% (or between about 60% and about 90%) cellulose matrix and between 10% and 40% (or between about 10% and about 40%) superabsorbent particles. For example, the absorbent layer may have about 20% superabsorbent material and about 80% cellulose fibers. It will be appreciated that rather than using super-absorbing particles or in addition

to such use, super-absorbing fibers can be utilized according to some embodiments of the present invention. An example of a suitable material is the Product Chem-Posite™ 11 C available from Emerging Technologies Inc (ETi) in the USA.

[0162] Super-absorber particles/fibers can be, for example, sodium polyacrylate or carbomethoxycellulose materials or the like or any material capable of absorbing many times its own weight in liquid. In some embodiments, the material can absorb more than five times its own weight of 0.9% W/W saline, etc. In some embodiments, the material can absorb more than 15 times its own weight of 0.9% W/W saline, etc. In some embodiments, the material is capable of absorbing more than 20 times its own weight of 0.9% W/W saline, etc. Preferably, the material is capable of absorbing more than 30 times its own weight of 0.9% W/W saline, etc. The absorbent layer 3430 can have one or more through holes 3431 located so as to underlie the suction port.

[0163] Some embodiments of the present disclosure may employ a masking or obscuring layer 3420 to help reduce the unsightly appearance of a dressing 3400 during use due to the absorption of wound exudate. The obscuring layer 3420 may be a colored portion of the absorbent material, or may be a separate layer that covers the absorbent material. The obscuring layer 3420 may be one of a variety of colors such as blue, orange, yellow, green, or any color suitable for masking the presence of wound exudate in the dressing 3400. For example, a blue obscuring layer 3420 may be a shade of blue similar to the shade of blue commonly used for the material of medical gowns, scrubs, and drapes. Some embodiments of the obscuring layer 3420 may comprise polypropylene spunbond material. Further, some embodiments of the obscuring layer 3420 may comprise a hydrophobic additive or coating. Other embodiments may comprise a thin fibrous sheet of 60, 70, or 80 gsm.

[0164] The obscuring layer may comprise at least one viewing window 3422 configured to allow a visual determination of the saturation level of the absorbent layer. The at least one viewing window 3422 may comprise at least one aperture made through the obscuring layer. The at least one viewing window 3422 may comprise at least one uncolored region of the obscuring layer. Some embodiments of the obscuring layer may comprise a plurality of viewing windows or an array of viewing windows, as discussed above with respect to Figures 25-32.

[0165] The masking capabilities of the obscuring layer 3420 should preferably only be partial, to allow clinicians to access the information they require by observing the spread of exudate across the dressing surface. A obscuring layer 3420 may be partial due to material properties allowing wound exudate to slightly alter the appearance of the dressing or due to the presence of at least one viewing window 3422 in a completely obscuring material. The partial masking nature of the obscuring layer 3420 enables a skilled clinician to perceive a different colour caused by exudate, blood, by-products etc. in the dressing allowing for a visual assessment and monitoring of the extent of spread across the dressing. However, since the change in colour of the dressing from its clean state to a state with exudate contained is only a slight change, the patient is unlikely to notice any aesthetic difference. Reducing or eliminating a visual indicator of wound exudate from a patient is likely to have a positive effect on their health, reducing stress for example.

[0166] Tests performed upon various dressings with respect to the transmittance properties of the dressing indicate the ability of various samples to mask colour. The ability to mask colour may be calculated, for example, by measuring the reduction in absorption of light radiation at particular wavelengths. The tests utilized a UV-Vis spectrophotometer Jasco with integrating sphere, with a scanning range 340 to 800 nm, bandwidth 5nm and 1000nm/sec scanning speed. The data labelled black background represents the extreme of exudate colour (the most colour an exudate might have) – the highest level of radiation absorbed and the least amount of radiation reflected from the sample. The data for white background represents the upper limit for total masking – generally the lowest level of radiation absorbed and the highest level of reflection. Sample 1 was a tinted polymer film placed over a black background, which was judged not to sufficiently mask the black background (representing wound exudate) satisfactorily. Sample 2 was a sheet of 3-dimensional spacer fabric (Baltex 3D) placed over a black background, and was judged to provide adequate masking of the black background. Sample 3 was a sheet of non-woven material dyed green placed over a black background, and provided complete masking of the black background.

[0167] Wound exudate may have dark yellow, red and/or brown tones. Therefore, to appropriately mask these colours, an obscuring layer 3420 would preferably shield light wavelengths of below 600 nm.

[0168] Measuring the reduction in absorption of light radiation at particular wavelengths may be performed by calculating:

$$\% \text{reduction} = (A_{\text{background}} - A_{\text{sample placed on background}}) / (A_{\text{background}}) \times 100$$

[0169] where A is the absorption of light radiation at the particular wavelength.

[0170] Using this formula, using light at a wavelength of 460nm, the percentage of absorption reduction was calculated as shown in Table 3 below.

TABLE 3

| Sample | Absorption reduction at 460 nm | Appropriate masking observed |
|---------------|---------------------------------------|-------------------------------------|
| Sample 1 | 34% | No |
| Sample 2 | 77% | Yes - partial |
| Sample 3 | 69% | Yes - complete |

[0171] It has been found that materials that reduce light absorption by about 50% or more will provide enough partial or complete masking of wound exudate (as judged by the inventors). Of course a complete masking element would preferably require a means for a clinician to judge the spread of wound exudate in the dressing below the obscuring layer 3420, e.g. the masking element not completely covering the entire dressing. For example, as described above with respect to Figures 25-33, a plurality of viewing windows may be provided in the obscuring layer 3420 such that the spread of exudate in the dressing below may be adequately assessed. Alternatively a partial masking element may allow a clinician to judge the spread of exudate in the dressing below without additional means.

[0172] It will be understood that the wetting of a masking material (by exudate for example) will also affect the masking performance of the masking element, since hydrophilic materials will allow chromophore-carrying species to travel through them more easily. As such, the absorption reduction rate should also be tested on wet materials.

[0173] The above-mentioned Samples 1, 2 and 3 were also tested for their masking properties by measuring CIE L*a*b* values (a known 3-dimensional model for

representing colour space). The analysis employed Jasco software using the range 380 to 780 nm, standard observed 2(deg), lightsource D65, colour matching JIS Z8701-1999.

[0174] Table 4 below shows the L*a*b* values found when Samples 1, 2 and 3 were respectively placed over a black background. The results for the black background alone and a white background are also shown.

TABLE 4

| Sample | CIE L*a*b* values recorded | | | Appropriate masking observed? |
|---------------------|----------------------------|-------|-------|-------------------------------|
| | L* | a* | b* | |
| Black background | 0 | 0 | 0 | n/a |
| Sample 1 (on black) | 36.59 | 3.76 | -1.80 | No |
| Sample 2 (on black) | 71.76 | -0.20 | -1.08 | Yes – partial |
| Sample 3 (on black) | 70.64 | -0.25 | -1.23 | Yes – complete |
| White background | 100 | 0 | 0 | n/a |

[0175] Generally, samples which lead to an increase in L* value will provide a lighter colour tone than the reference surface, which is the main contributor to masking a dark colour. From the values above, apt partial masking materials will yield an L* value above 50, or more aptly above 70.

[0176] However, completely opaque masking layers, such as for example a tinted polymeric film, may cover the area to be masked with a darker tone altogether, in which case the measure of L* is not relevant. Once again these values should also be considered on wet material, for the reasons stated above.

[0177] In addition to transmittance properties, the color of the obscuring layer 3420 may affect the masking ability of the layer. In liquid permeable embodiments of the obscuring layer, various colors are suitable for masking the usual colors of wound exudate, while other colors may not provide optimal masking of the exudate. For

example, with reference to the CIE chromaticity diagram illustrated in Figure 38, some embodiments of the obscuring layer, in a dry state, may be configured to yield a CIE y value of .4 or less and a CIE x value of .5 or less. Some embodiments of the obscuring layer, in a dry state, may have a color of Bg, gB, B, pB, bP, P, rP, pPk, RP, O, rO, or yO on the CIE x, y chromaticity diagram. It will be appreciated that liquid impermeable embodiments of the obscuring layer may be configured with any color.

[0178] The obscuring layer 3420 can have one or more through holes located so as to underlie the suction port. Some embodiments may have a maltese cross 3421 or other shaped cutout underlying the suction port, wherein the diameter of the maltese cross 3421 is greater than the diameter of the port. This may allow a clinician to easily assess the amount of wound exudate absorbed into the layers beneath the port.

[0179] The dressing 3400 may also comprise a backing layer, or cover layer 3410 extending across the width of the wound dressing. The cover layer 3410 may be gas impermeable but moisture vapor permeable. Some embodiments may employ a polyurethane film (for example, Elastollan SP9109) or any other suitable material. For example, certain embodiments may comprise translucent or transparent 30gsm EU33 film. The cover layer 3410 may have a pressure sensitive adhesive on the lower side, thereby creating a substantially sealed enclosure over the wound in which negative pressure may be established. The cover layer can protect the wound as a bacterial barrier from external contamination, and may allow liquid from wound exudates to be transferred through the layer and evaporated from the film outer surface.

[0180] The cover layer 3410 can have an orifice 3411 located so as to underlie the suction port. The orifice 3411 may allow transmission of negative pressure through the cover layer 3410 to the wound enclosure. The port may be adhered and sealed to the cover film using an adhesive such as an acrylic, cyanoacrylate, epoxy, UV curable or hot melt adhesive. Some embodiments may have a plurality of orifices for the attachment of multiple ports or other sources of negative pressure or other mechanisms for distributing fluid.

[0181] Figure 34B illustrates a cross sectional view of the wound dressing 3400, displaying an embodiment of the relative thicknesses of layers of the dressing 3400. In some embodiments, the wound contact layer 3460 may be flat and the top film layer 3410 may be contoured over the inner layers of the dressing 3400. The spacer layer 3450 may be half as thick as the acquisition distribution layer 3440 in some embodiments. In

some embodiments, the absorbent layer 3430 may be about 1.5 times thicker than the spacer layer 3450. The obscuring layer 3420 may be about half the thickness of the spacer layer 3450.

[0182] Figure 35 illustrates a perspective exploded view of an embodiment of a flexible port or fluidic connector 3500 that may be used to connect any of the wound dressings described herein to a source of negative pressure. The port 3500 comprises a top layer 3510, a spacer layer 3520, a filter element 3530, a bottom layer 3540, and a conduit 3550. The conduit optionally comprises a connector 3560. The distal end of the port 3500 (the end connectable to the dressing 3400) is depicted as having an enlarged circular shape, although it will be appreciated that any suitable shape may be used and that the distal end need not be enlarged. For example, the distal end can have any of the shapes shown in Figures 23A and 23B above. The distal end can also have the shape shown in Figures 3A-3C of Provisional Application Serial No. 61/650,904, filed May 23, 2012, incorporated by reference herein and included as an appendix.

[0183] The bottom layer 3540 may comprise an elongate bridge portion 3544, an enlarged (e.g., rounded or circular) sealing portion 3545, and an orifice 3541. In some embodiments a plurality of orifices may be provided in the bottom layer. Some embodiments of the rounded sealing portion 3545 may comprise a layer of adhesive, for example a pressure sensitive adhesive, on the lower surface for use in sealing the port 3500 to a dressing. For example, the port may be sealed to the cover layer 3410 of the dressing in Figure 34. The orifice 3541 in the bottom layer 3540 of the port 3500 may be aligned with the orifice 3411 in the cover layer 3410 of the dressing 3400 in order to transmit negative pressure through the dressing 3400 and into a wound site.

[0184] The top layer 3515 may be substantially the same shape as the bottom layer in that it comprises an elongate bridge 3514 and an enlarged (e.g., rounded or circular) portion 3515. The top layer 3515 and the bottom layer 3545 may be sealed together, for example by heat welding. In some embodiments, the bottom layer 3545 may be substantially flat and the top layer 3515 may be slightly larger than the bottom layer 3545 in order to accommodate the height of the spacer layer 3520 and seal to the bottom layer 3545. In other embodiments, the top layer 3515 and bottom layer 3145 may be substantially the same size, and the layers may be sealed together approximately at the middle of the height of the spacer layer 3520. In some embodiments, the elongate bridge portions 3544, 3514 may have a length of 10 cm (or about 10 cm) or more, more

preferably a length of 20 cm (or about 20 cm) or more and in some embodiments, may be about 27 cm long. In some embodiments, the elongate bridge portions may have a width of between 1 cm and 4 cm (or between about 1 cm and about 4 cm), and in one embodiment, is about 2.5 cm wide. The ratio of the length of the elongate bridge portions 3544, 3514 to their widths may in some embodiments exceed 6:1, and may more preferably exceed 8:1 or even 10:1. The diameter of the circular portion 3545, 3515 may be about 3.5 cm in some embodiments.

[0185] The bottom and top layers may comprise at least one layer of a flexible film, and in some embodiments may be transparent. Some embodiments of the bottom layer 3540 and top layer 3515 may be polyurethane, and may be liquid impermeable.

[0186] The port 3500 may comprise a spacer layer 3520, such as the 3D fabric discussed above, positioned between the lower layer 3540 and the top layer 3510. The spacer layer 3520 may be made of any suitable material, for example material resistant to collapsing in at least one direction, thereby enabling effective transmission of negative pressure therethrough. The spacer layer 3520 may comprise an enlarged (e.g., rounded or circular) portion 3525, and may optionally include a fold 3521. In some embodiments, the elongate bridge portion may have dimensions in the same ranges as the bridge portions of the upper and lower layers described above though slightly smaller, and in one embodiment is about 25.5 cm long and 1.5 cm wide. Similarly, the diameter of the circular portion 3525 may be slightly smaller than the diameters of the enlarged ends 3545, 3515, and in one embodiment is about 2 cm. Some embodiments of the spacer layer 3520 may have adhesive on one or both of its proximal and distal ends (e.g., one or more dabs of adhesive) in order to secure the spacer layer 3520 to the top layer 3510 and/or the bottom layer 3540. Adhesive may also be provided along a portion or the entire length of the spacer layer. In other embodiments, the spacer layer 3520 may be freely movable within the sealed chamber of the top and bottom layers.

[0187] The fold 3521 of the spacer fabric may make the end of the port 3500 softer and therefore more comfortable for a patient, and may also help prevent the conduit 3550 from blockage. The fold 3521 may further protect the end of the conduit 3550 from being occluded by the top or bottom layers. The fold 3521 may, in some embodiments, be between 1 cm and 3 cm (or between about 1 cm and about 3 cm) long, and in one embodiment is 2 cm (or about 2 cm) long. The spacer fabric may be folded underneath itself, that is toward the bottom layer 3540, and in other embodiments may be folded

upward toward the top layer 3510. Other embodiments of the spacer layer 3520 may contain no fold. A slot or channel 3522 may extend perpendicularly away from the proximal end of the fold 3521, and the conduit 3550 may rest in the slot or channel 3522. In some embodiments the slot 3522 may extend through one layer of the fold, and in others it may extend through both layers of the fold. The slot 3522 may, in some embodiments, be 1 cm (or about 1 cm) long. Some embodiments may instead employ a circular or elliptical hole in the fold 3521. The hole may face proximally so that the conduit 3550 may be inserted into the hole and rest between the folded layers of spacer fabric. In some embodiments, the conduit 3550 may be adhered to the material of the fold 3521, while in other embodiments it may not.

[0188] The port 3500 may have a filter element 3530 located adjacent the orifice 3541, and as illustrated is located between the lower layer 3540 and the spacer layer 3520. , As illustrated, the filter element 3530 may have a round or disc shape. The filter element 3530 is impermeable to liquids, but permeable to gases. The filter element 3530 can act as a liquid barrier, to substantially prevent or inhibit liquids from escaping from the wound dressing, as well as an odor barrier. The filter element 3530 may also function as a bacterial barrier. In some embodiments, the pore size of the filter element 3530 can be approximately 0.2 μ m. Suitable materials for the filter material of the filter element include 0.2 micron Gore™ expanded PTFE from the MMT range, PALL Versapore™ 200R, and Donaldson™ TX6628. The filter element 3530 thus enables gas to be exhausted through the orifice. Liquid, particulates and pathogens however are contained in the dressing. Larger pore sizes can also be used but these may require a secondary filter layer to ensure full bioburden containment. As wound fluid contains lipids it is preferable, though not essential, to use an oleophobic filter membrane for example 1.0 micron MMT-332 prior to 0.2 micron MMT-323. This prevents the lipids from blocking the hydrophobic filter. In some embodiments, the filter element 3530 may be adhered to one or both of top surface of the bottom layer 3540 and the bottom surface of the spacer layer 3520 using an adhesive such as, but not limited to, a UV cured adhesive. In other embodiments, the filter 3530 may be welded to the inside of the spacer layer 3520 and to the top surface of the bottom layer 3540. The filter may also be provided adjacent the orifice on a lower surface of the bottom layer 3540. Other possible details regarding the filter are disclosed in U.S. Patent Pub. No. 2011/0282309 and incorporated by reference herein.

[0189] The proximal end of the port 3500 may be connected to the distal end of a conduit 3550. The conduit 3550 may comprise one or more circular ribs 3551. The ribs 3551 may be formed in the conduit 3550 by grooves in a mold during the manufacturing of the conduit. During heat welding of the upper and lower layers 3515, 3545 melted material from those layers may flow around the ribs 3551, advantageously providing a stronger connection between the conduit 3550 and the layers. As a result, it may be more difficult to dislodge the conduit 3550 out from between the layers during use of the port 3500.

[0190] The proximal end of the conduit 3550 may be optionally attached to a connector 3560. The connector 3560 may be used to connect the port 3500 to a source of negative pressure, or in some embodiments to an extension conduit which may in turn be connected to a source of negative pressure. The distal end of the conduit 3550, which is inserted into the spacer layer 3520, may be shaped in such a way to reduce the possibility of occlusion.

[0191] Figure 36 illustrates an embodiment of a wound dressing 3610 with a flexible port 3620 such as described with respect to Figure 35 attached. The port 3620 comprises a conduit 3630 and a connector 3640 for connecting the port to a source of negative pressure or to an extension conduit. The dressing 3610 comprises an obscuring layer with one row of eight holes in a linear arrangement, and is described above in more detail with respect to Figure 25. Although in this depiction the port 3620 is connected over a circular window in the obscuring layer of the dressing 3610, in other embodiments the port 3620 may be connected over a maltese cross in the obscuring layer. In some embodiments, the maltese cross may be of a larger diameter than the port and may be at least partially viewable after the port is attached to the dressing.

[0192] Figure 37A illustrates a perspective view of an embodiment of the dressing. Although the configuration as depicted is similar to the embodiment of Figure 29B, the dressing can have any of the constructions of different layers previously described. Conduit 3710 is connected to the dressing 3700 via port 3720, however other embodiments of ports may be connected to the dressing, for example the flexible port of Figure 35.

[0193] Figure 37B illustrates a bottom view of the dressing 3700. The view illustrates a transmission layer 3730 and an acquisition distribution layer 3740, which may be similar to the transmission layer 3450 and acquisition distribution layer 3440 of

Figures 34A and 34B. In some embodiments, the perimeter of the transmission layer 3730 may be slightly smaller than the perimeter of the acquisition distribution layer 3740. The view also illustrates one embodiment of a release layer 3750 similar to release layer 3480 previously described for use in protecting the adhesive side of the wound contact layer. The release layer 3750 as illustrated is made of two separate layers of material that can be removed from the adhesive side of the wound contact layer by pulling on flaps attached to the release layer.

[0194] It will be of course appreciated that other dressing configurations are possible other than a narrow central portion configuration, a three-lobed configuration, a four-lobed configuration, including, for example, hexagonal or circular shaped backing layers for use in dressings. As illustrated in Figures 15A-B, these embodiments may also comprise various configurations of slits, described previously, so as to enhance conformability of the dressing in non-planar wounds. Also, as described previously, the absorbent layers of these embodiments may be colored or obscured with an obscuring layer, and optionally provided with one or more viewing windows. Further, the domed ports of these embodiments may also be replaced with one or more fluidic connectors of the type described below in Figures 23A-B, and vice versa. Additionally, all features and structures described for wound dressings with the waisted portion configuration can be incorporated into any shape or dressing configuration as described herein.

[0195] Features, materials, characteristics, or groups described in conjunction with a particular aspect, embodiment, or example are to be understood to be applicable to any other aspect, embodiment or example described herein unless incompatible therewith. All of the features disclosed in this specification (including any accompanying claims, abstract and drawings), and/or all of the steps of any method or process so disclosed, may be combined in any combination, except combinations where at least some of such features and/or steps are mutually exclusive. The protection is not restricted to the details of any foregoing embodiments. The protection extends to any novel one, or any novel combination, of the features disclosed in this specification (including any accompanying claims, abstract and drawings), or to any novel one, or any novel combination, of the steps of any method or process so disclosed.

[0196] While certain embodiments have been described, these embodiments have been presented by way of example only, and are not intended to limit the scope of protection. Indeed, the novel methods and systems described herein may be embodied in

a variety of other forms. Furthermore, various omissions, substitutions and changes in the form of the methods and systems described herein may be made. Those skilled in the art will appreciate that in some embodiments, the actual steps taken in the processes illustrated and/or disclosed may differ from those shown in the figures. Depending on the embodiment, certain of the steps described above may be removed, others may be added. Furthermore, the features and attributes of the specific embodiments disclosed above may be combined in different ways to form additional embodiments, all of which fall within the scope of the present disclosure.

[0197] Although the present disclosure includes certain embodiments, examples and applications, it will be understood by those skilled in the art that the present disclosure extends beyond the specifically disclosed embodiments to other alternative embodiments and/or uses and obvious modifications and equivalents thereof, including embodiments which do not provide all of the features and advantages set forth herein. Accordingly, the scope of the present disclosure is not intended to be limited by the specific disclosures of preferred embodiments herein, and may be defined by claims as presented herein or as presented in the future.

[0198] The reader's attention is directed to all papers and documents which are filed concurrently with or previous to this specification in connection with this application and which are open to public inspection with this specification, and the contents of all such papers and documents are incorporated herein by reference.

[0199] It is to be understood that, if any prior art publication is referred to herein, such reference does not constitute an admission that the publication forms a part of the common general knowledge in the art, in Australia or any other country.

[0200] In the claims which follow and in the preceding description of the invention, except where the context requires otherwise due to express language or necessary implication, the word "comprise" or variations such as "comprises" or "comprising" is used in an inclusive sense, i.e. to specify the presence of the stated features but not to preclude the presence or addition of further features in various embodiments of the invention.

WHAT IS CLAIMED IS:

1. An apparatus for dressing a wound comprising:
a substantially rectangular or square fibrous absorbent layer having one or more slits configured to enhance conformability when the apparatus is applied to a non-planar or contoured wound area, the one or more slits extending at least partially across the width of the absorbent layer;
a fibrous acquisition distribution layer positioned below the absorbent layer; and
a backing layer above the absorbent layer.
2. The apparatus of claim 1, wherein each of the slits do not extend entirely across the width of the dressing.
3. The apparatus of claim 1 or claim 2, wherein the slits are distributed concentrically.
4. The apparatus of any one of claims 1 to 3, wherein the one or more slits are arc-shaped.
5. The apparatus of any one of claims 1 to 4, wherein one of the at least one or more slits has a different size with another of said at least one or more slits.
6. The apparatus of any one of claims 1 to 5, wherein at least one slit has a different size with another slit.
7. The apparatus of any one of claims 1 to 6, wherein the one or more slits have an alternating pattern.
8. The apparatus of any one of claims 1 to 7, wherein the one or more slits comprise a cut centered adjacent an edge of the absorbent layer.
9. The apparatus of any one of claims 1 to 8, wherein the absorbent layer comprises a super absorbent material.

10. The apparatus of any one of claims 1 to 9, further comprising a transmission layer configured to allow for the passage of fluid therethrough.
11. The apparatus of claim 10, wherein the transmission layer comprises a porous material or a non-woven fabric material.
12. The apparatus of claim 10 or claim 11, wherein the transmission layer is below the absorbent layer.
13. The apparatus of any one of claims 10 to 12, further comprising a wound contact layer below the transmission layer, wherein the wound contact layer is adhered to the backing layer, and wherein the backing layer and the wound contact layer have the same size and shape.
14. The apparatus of any one of claims 1 to 13, wherein the acquisition distribution layer is configured to horizontally wick fluid as it is absorbed upward through the absorbent layer.
15. An apparatus for dressing a wound comprising:
 - a substantially rectangular or square fibrous absorbent layer having one or more slits configured to enhance conformability when the apparatus is applied to a non-planar or contoured wound area, the plurality of slits extending at least partially across the absorbent layer and intersecting with an edge of the absorbent layer;
 - a cover layer positioned over the absorbent layer, the cover layer extending beyond the boundary of the absorbent layer and configured to seal to skin surrounding a wound.
16. The apparatus for dressing a wound of claim 15, where the absorbent layer comprises a narrowed central portion.
17. The apparatus for dressing a wound of claim 15 or claim 16, further comprising a silicone adhesive layer below the absorbent layer.

18. The apparatus for dressing a wound of any one of claims 15 to 17, wherein the absorbent layer comprises foam.
19. The apparatus of any one of claims 15 to 18, wherein the absorbent layer comprises superabsorbent particles.
20. The apparatus of any one of claims 15 to 19, further comprising an acquisition distribution layer positioned beneath the absorbent layer.
21. The apparatus of claim 20, wherein the acquisition distribution layer comprises viscose.
22. The apparatus of any one of claims 15 to 21, wherein each slit is configured such that if the slit were extended in a straight line across the width of the absorbent layer, the slit would not intersect with another slit.

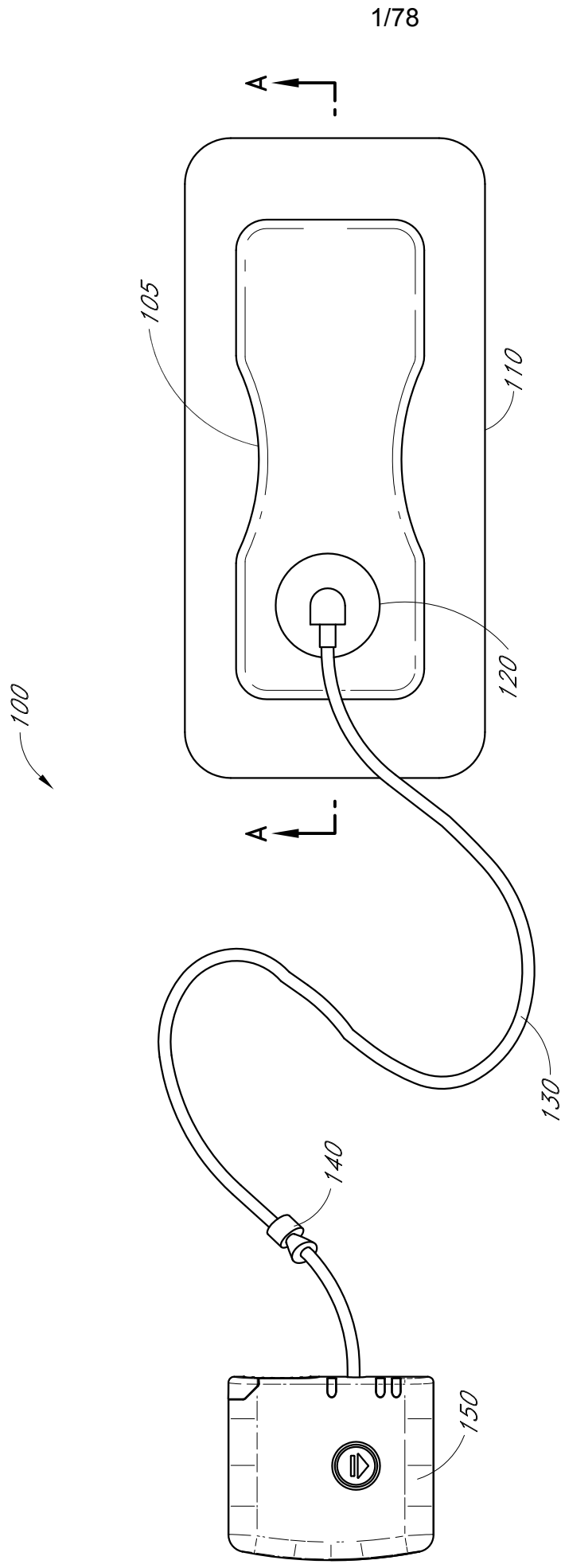

FIG. 1

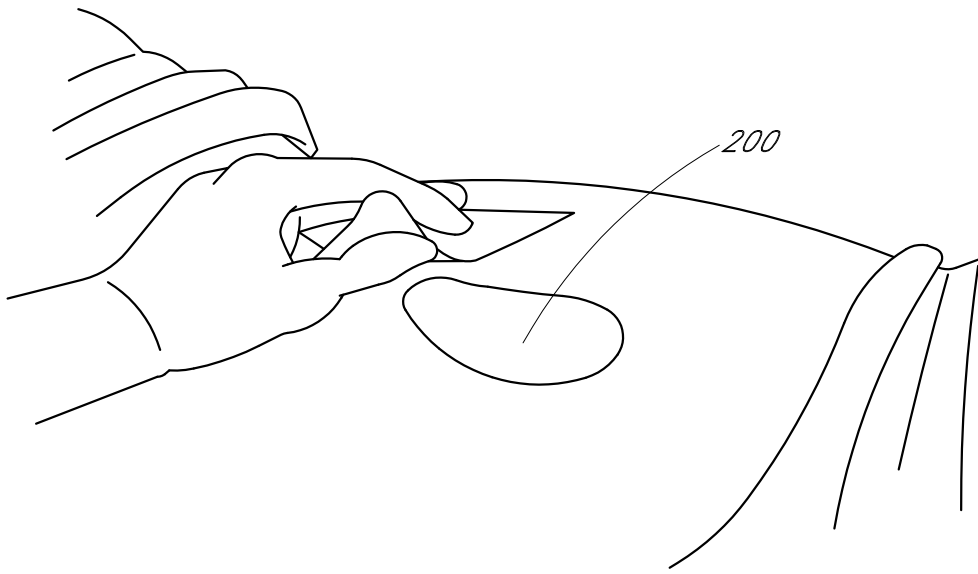

FIG. 2A

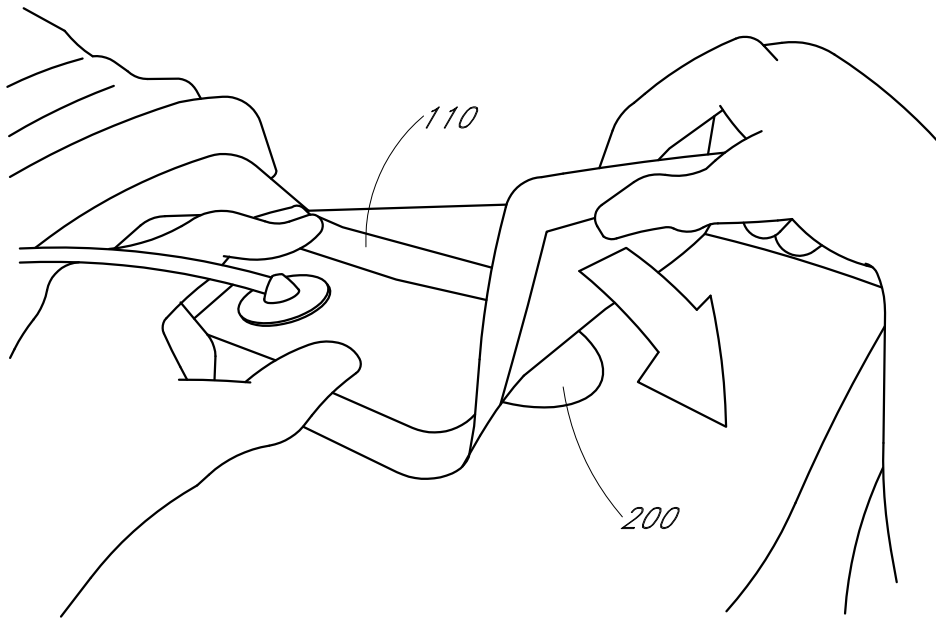

FIG. 2B

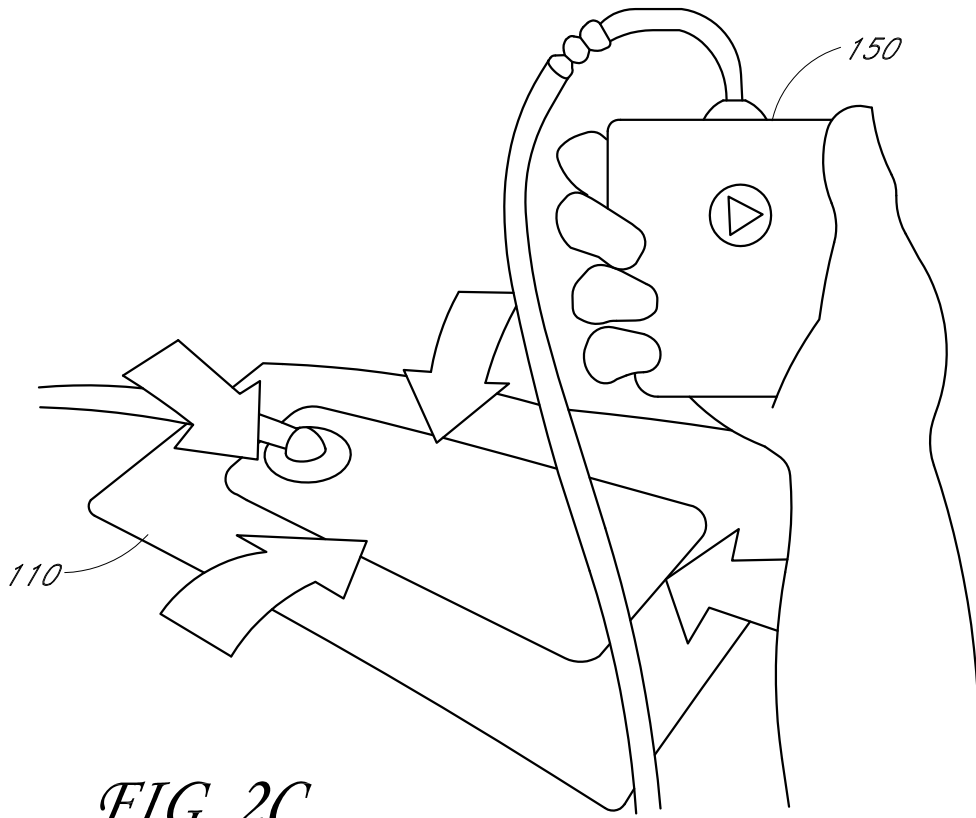

FIG. 2C

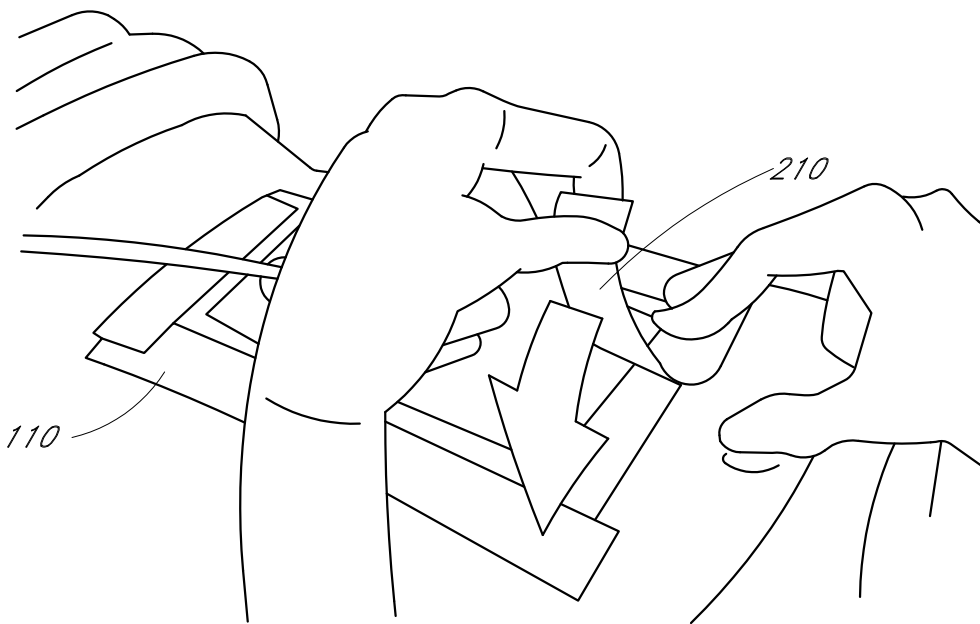

FIG. 2D

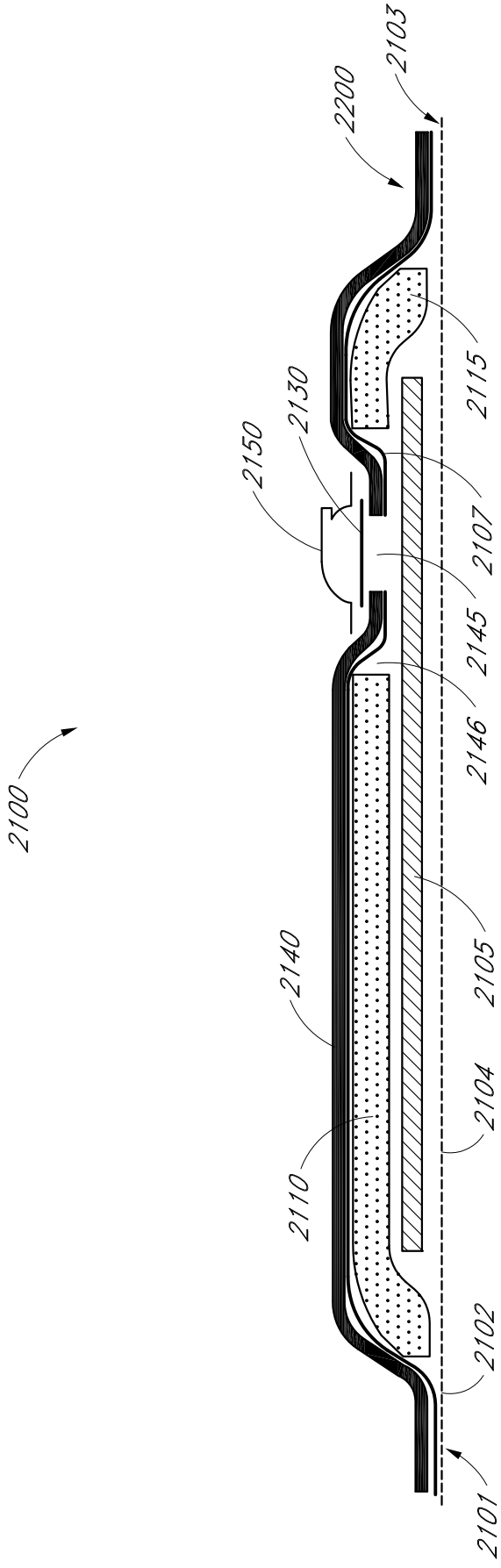

FIG. 3A

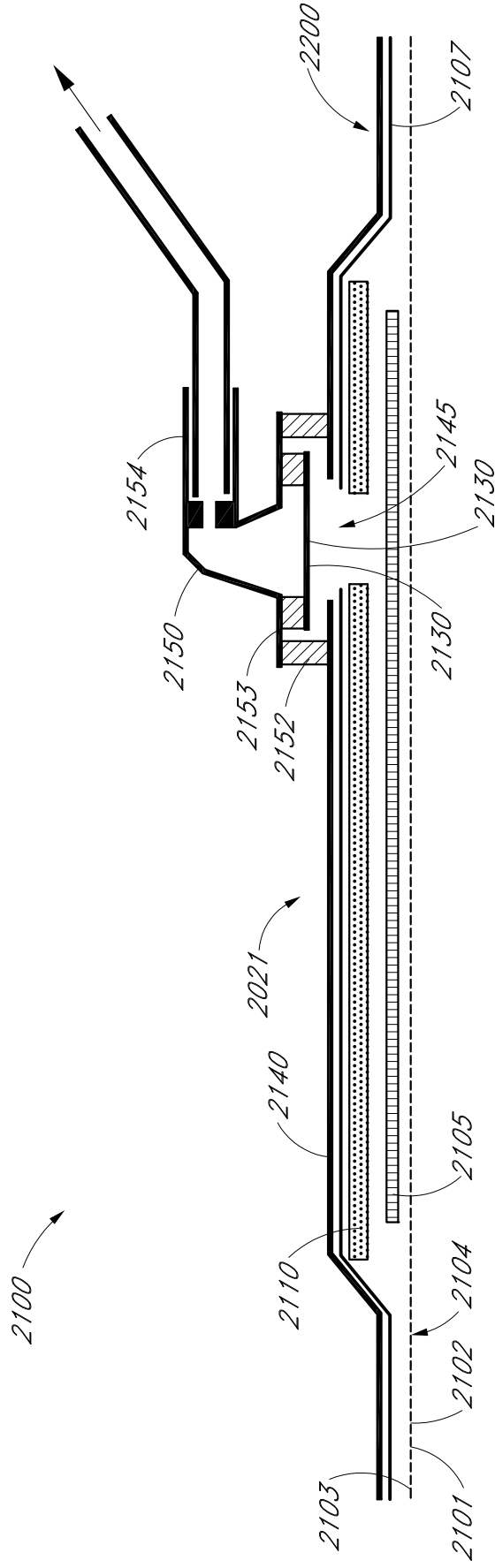

FIG. 3B

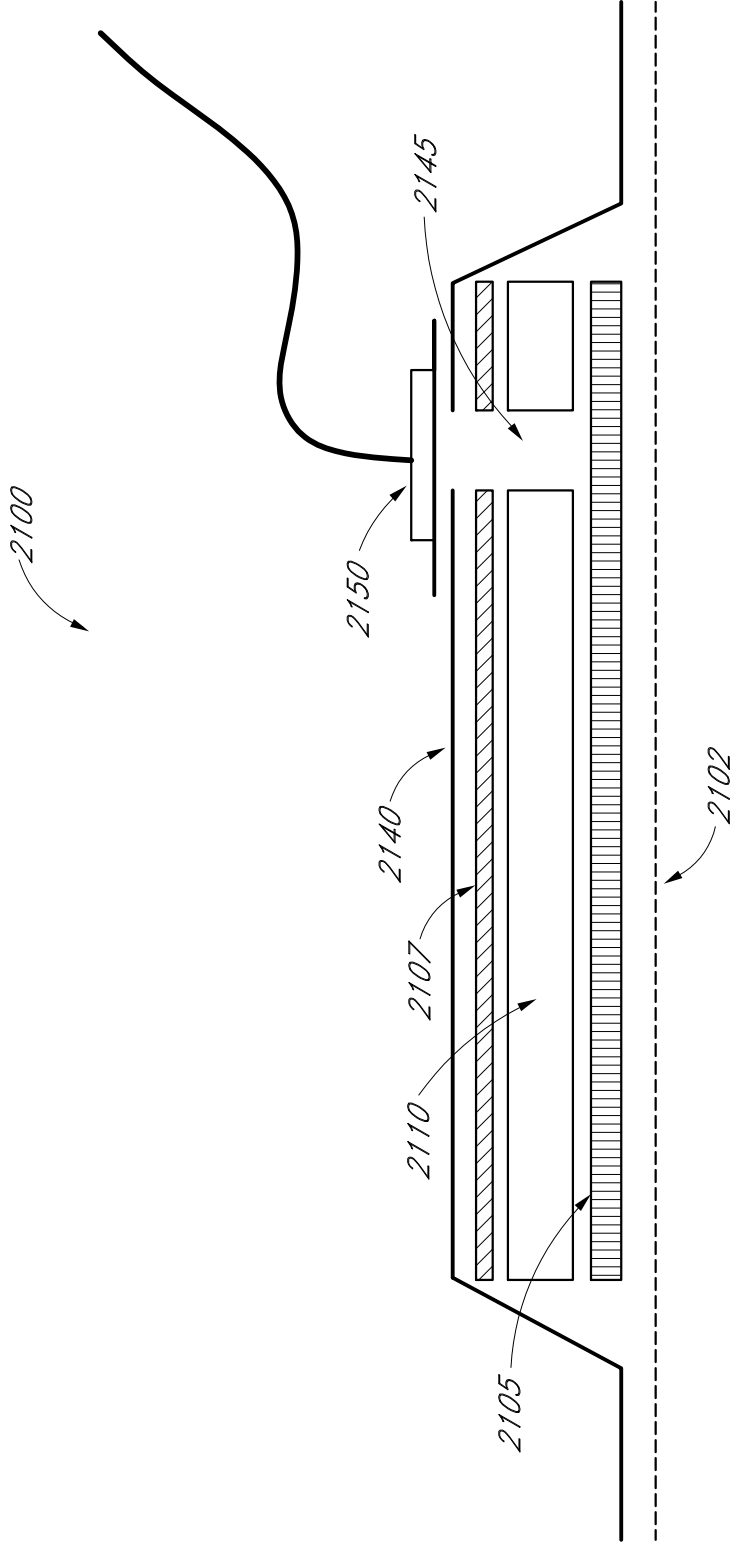

FIG. 3C

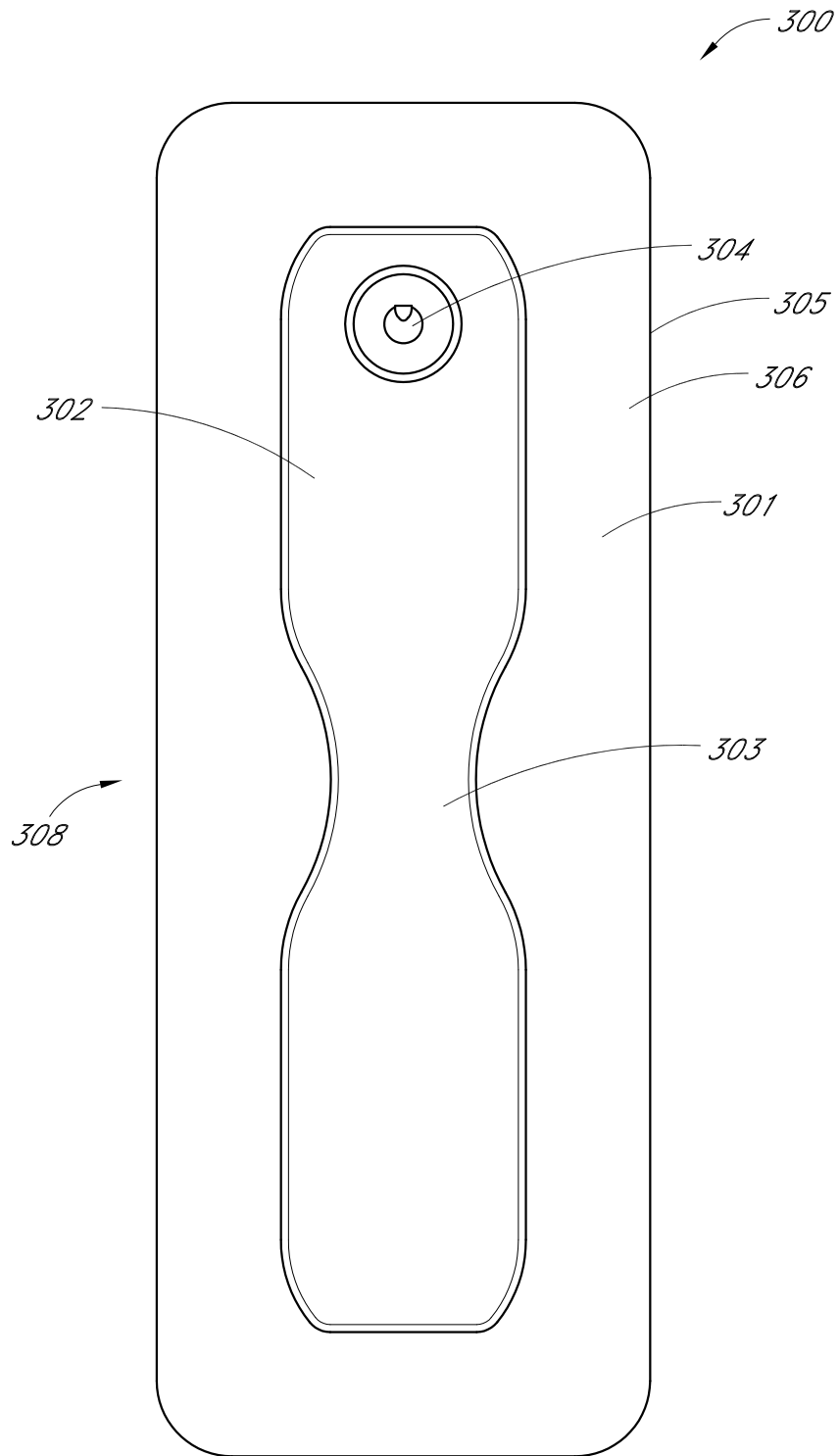

FIG. 4A

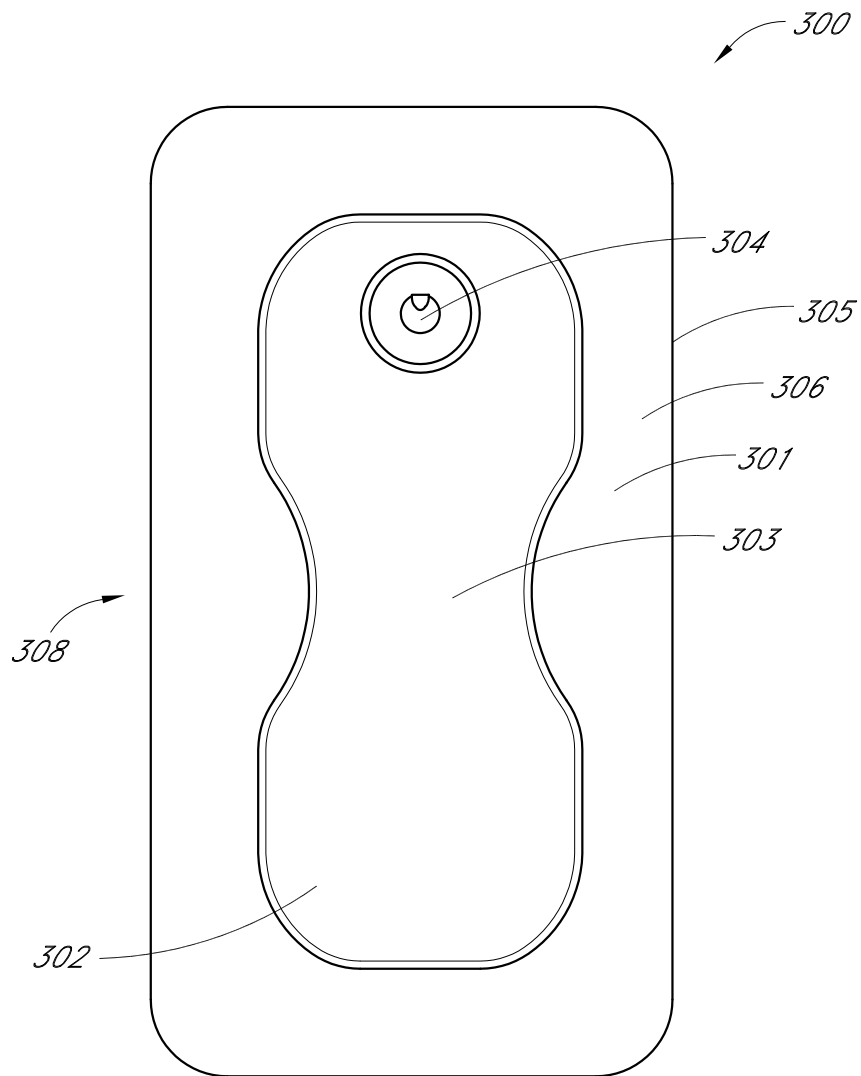

FIG. 4B

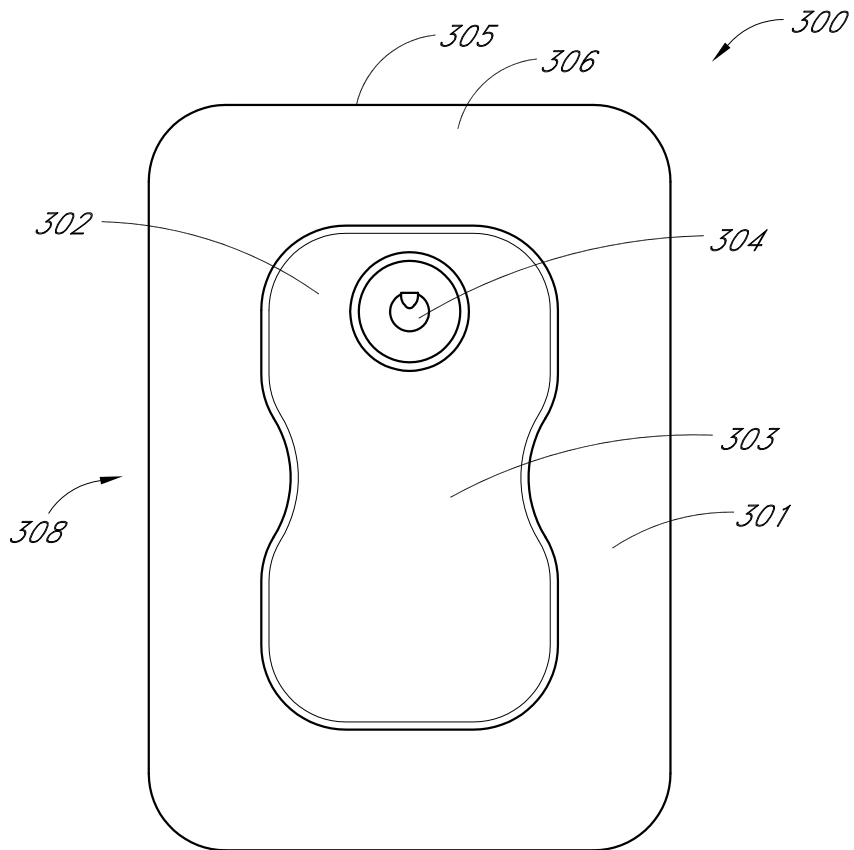

FIG. 4C

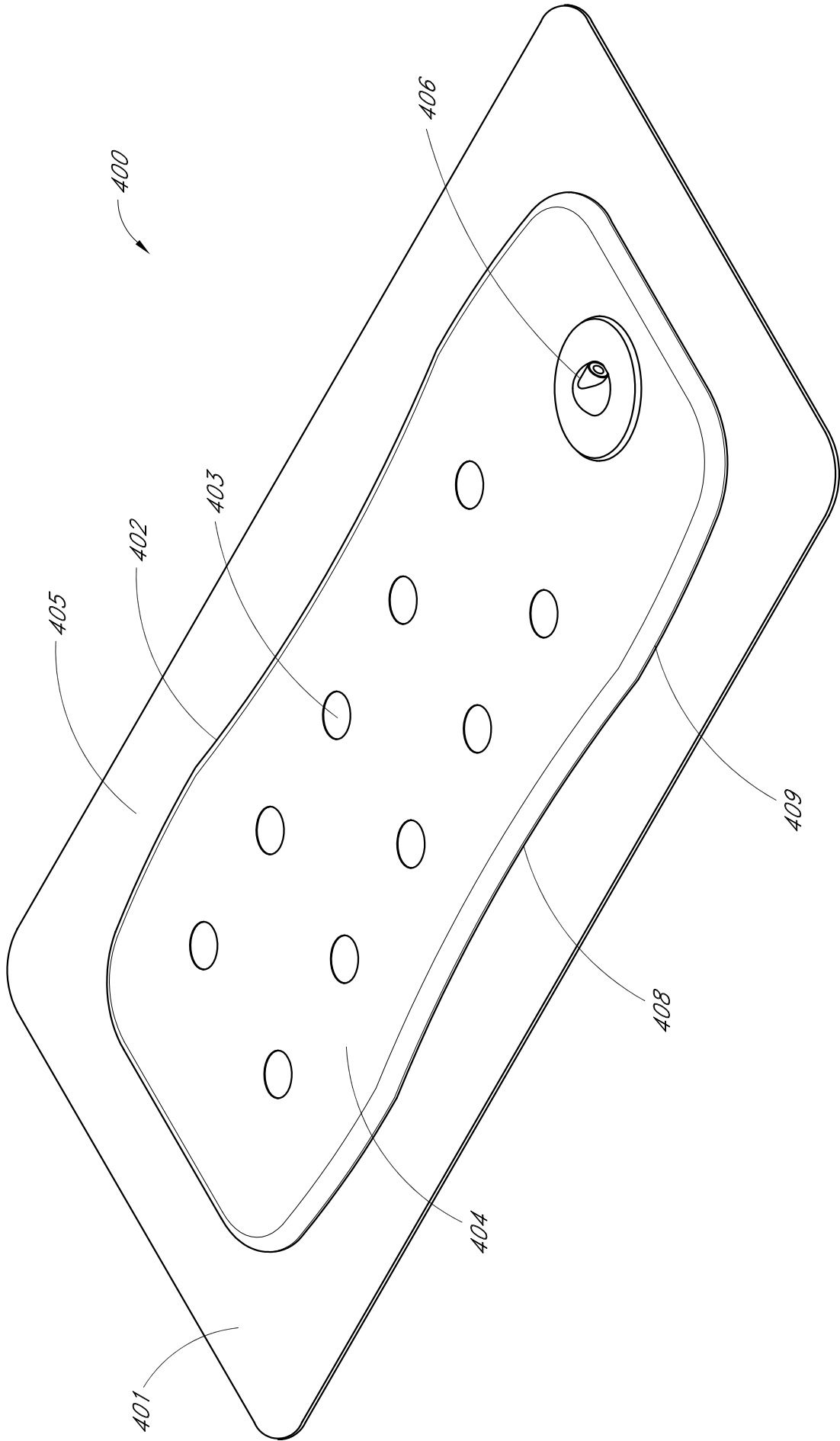

FIG. 5A

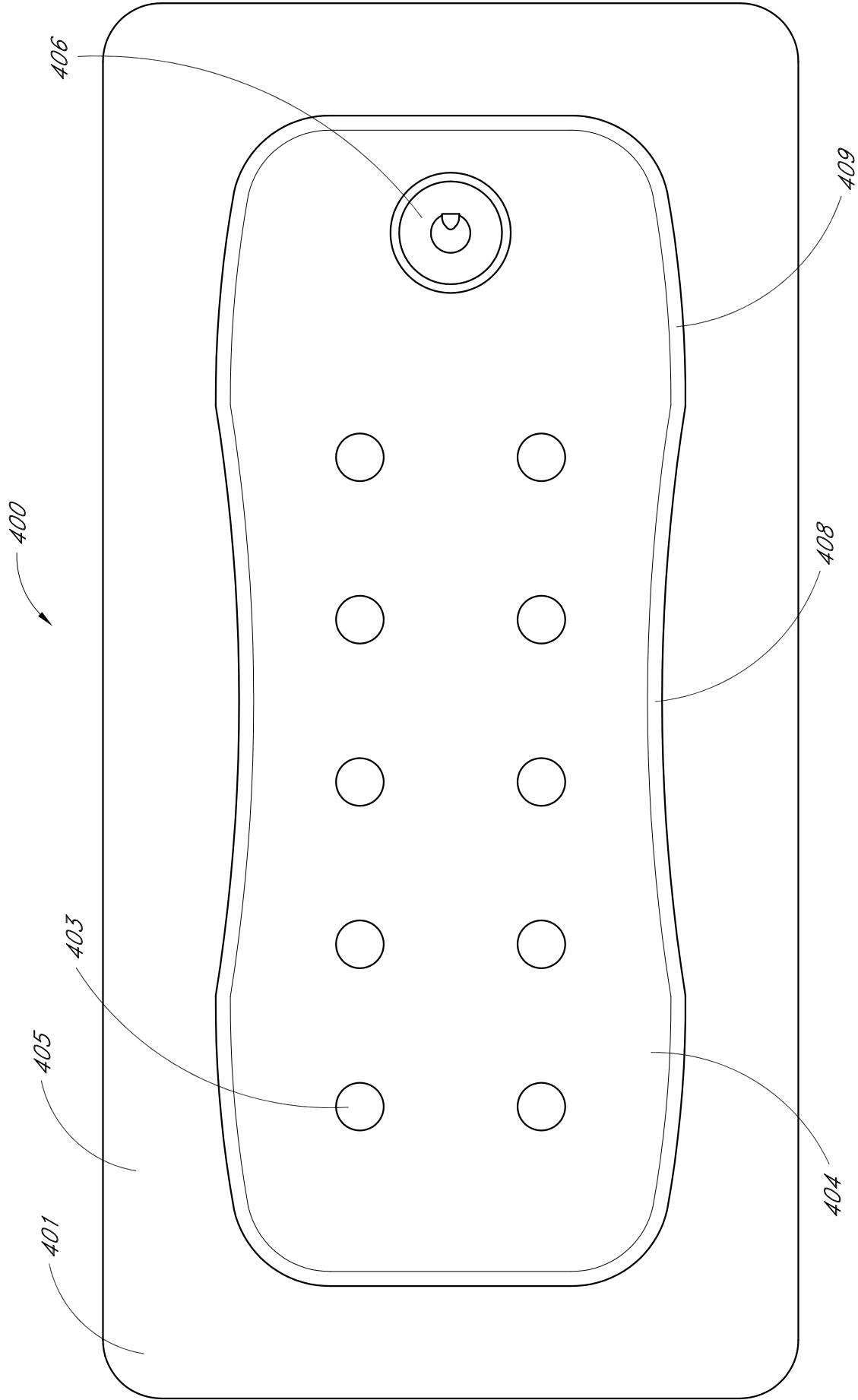

FIG. 5B

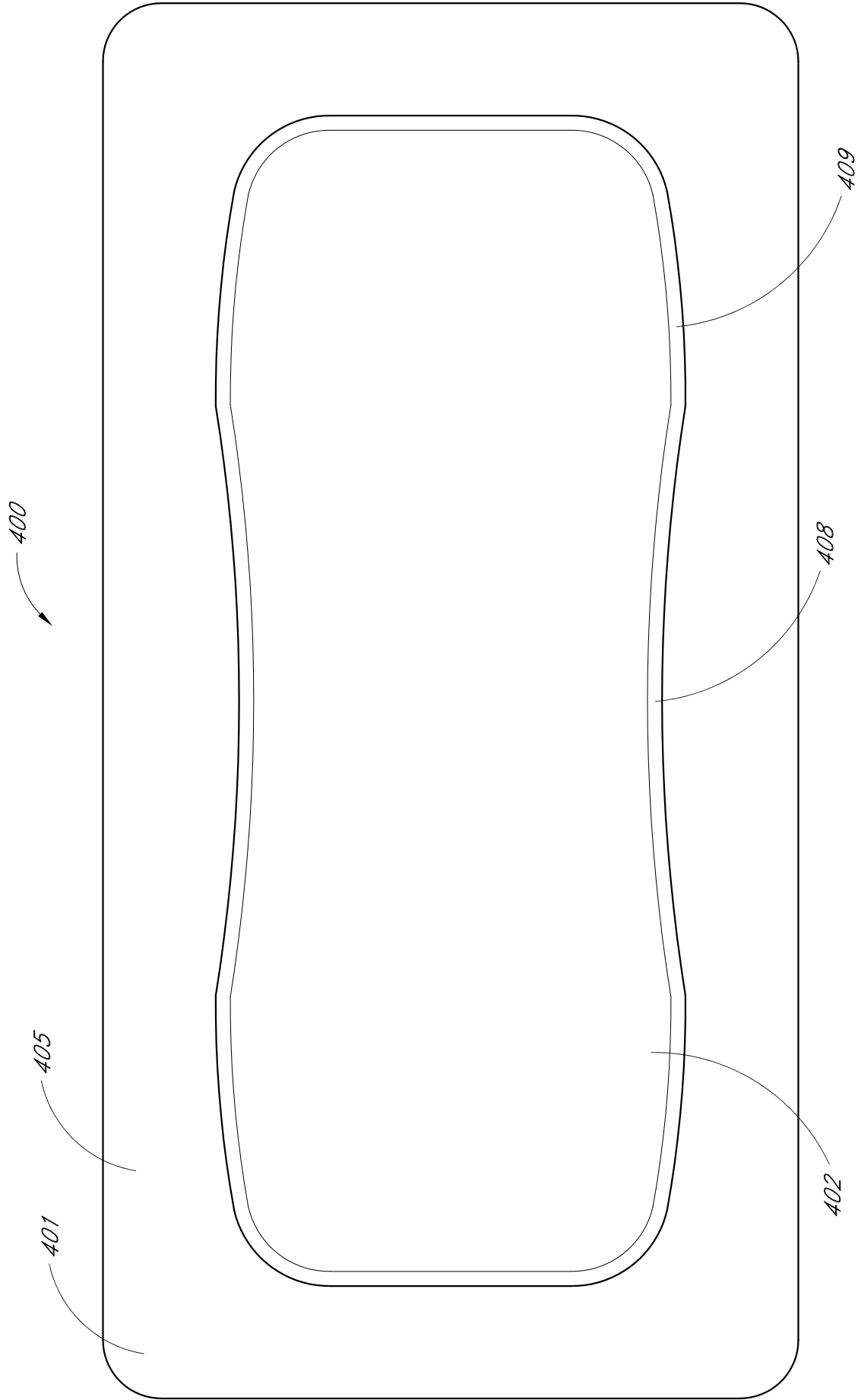

FIG. 5C

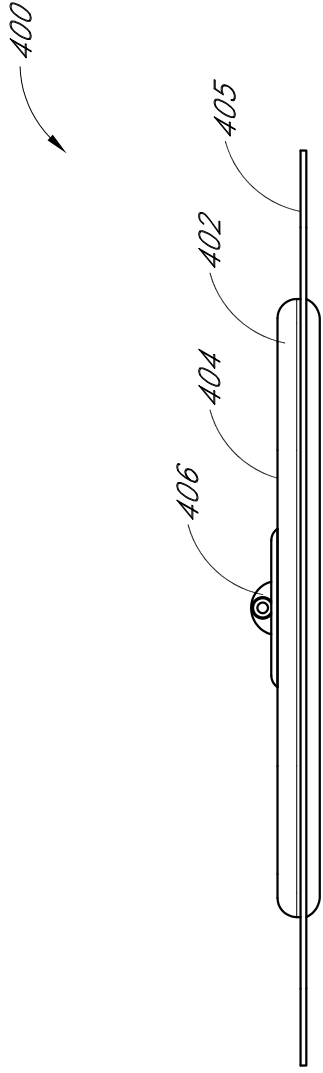

FIG. 5D

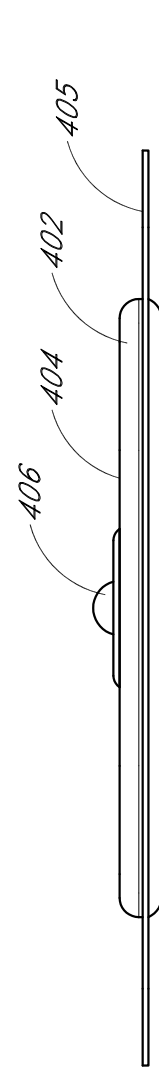

FIG. 5E

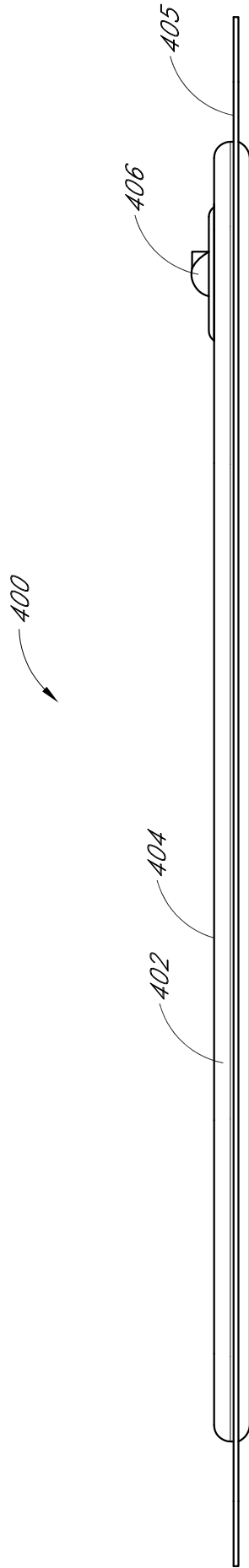

FIG. 5F

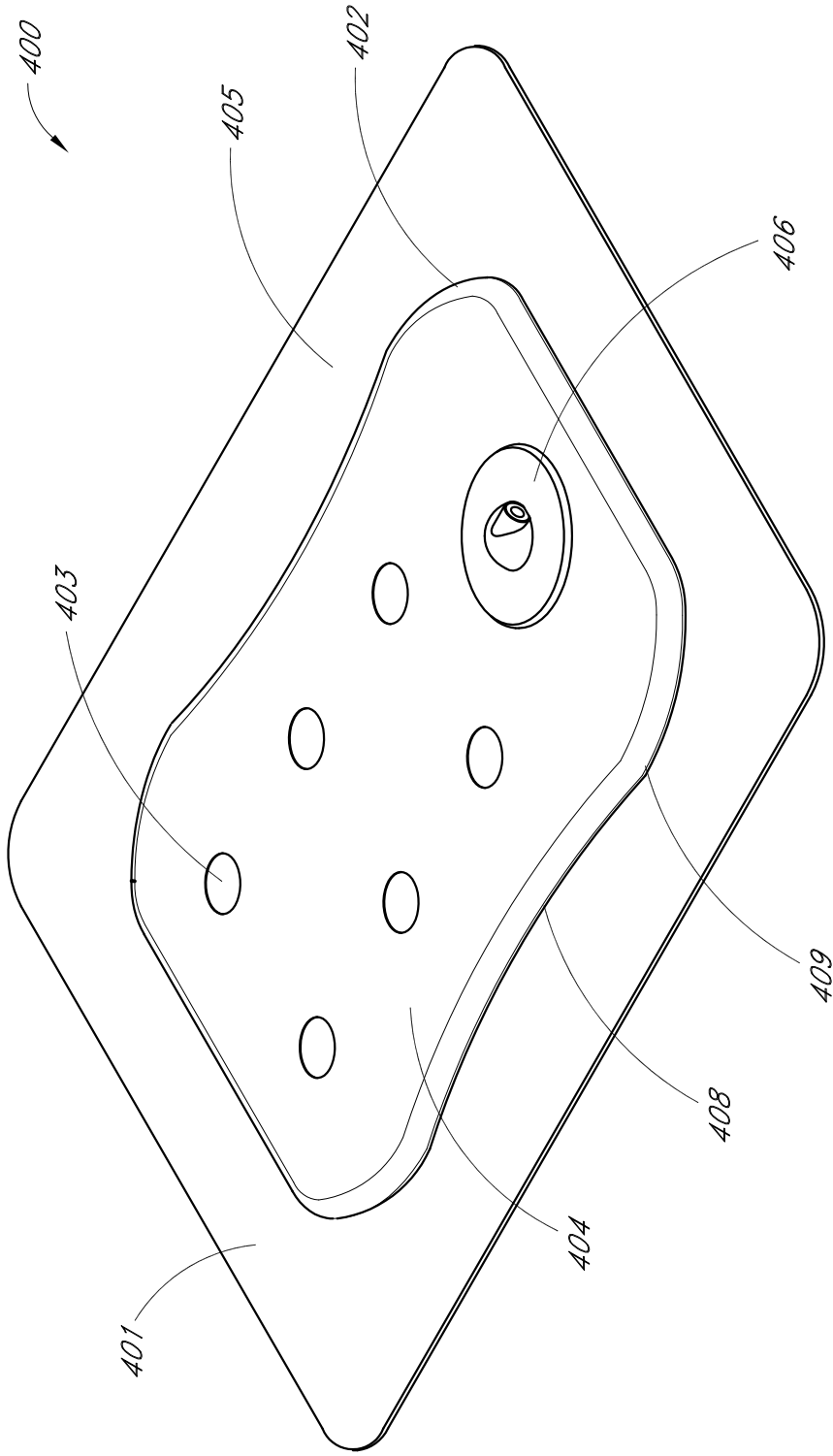

FIG. 6A

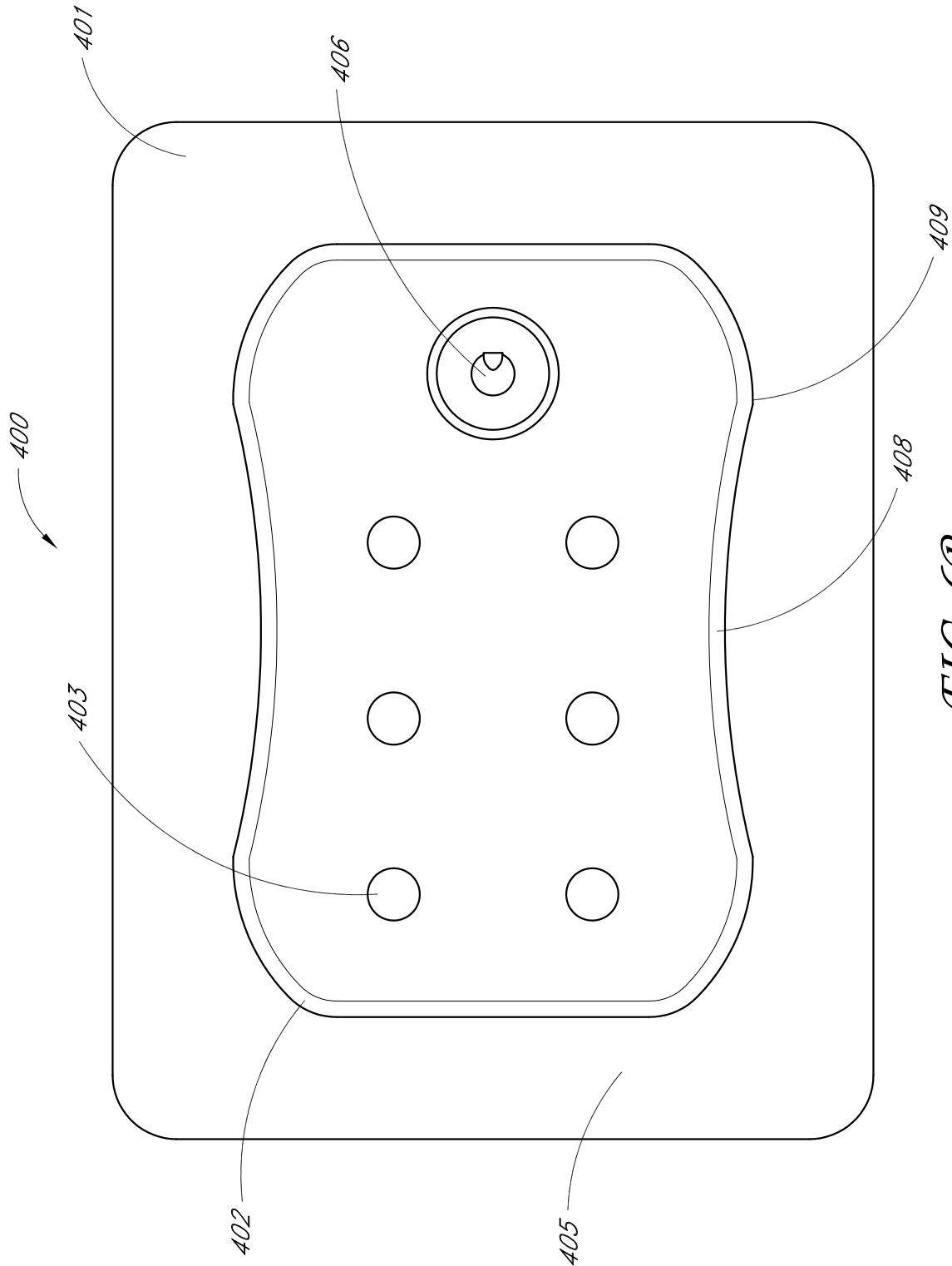

FIG. 6B

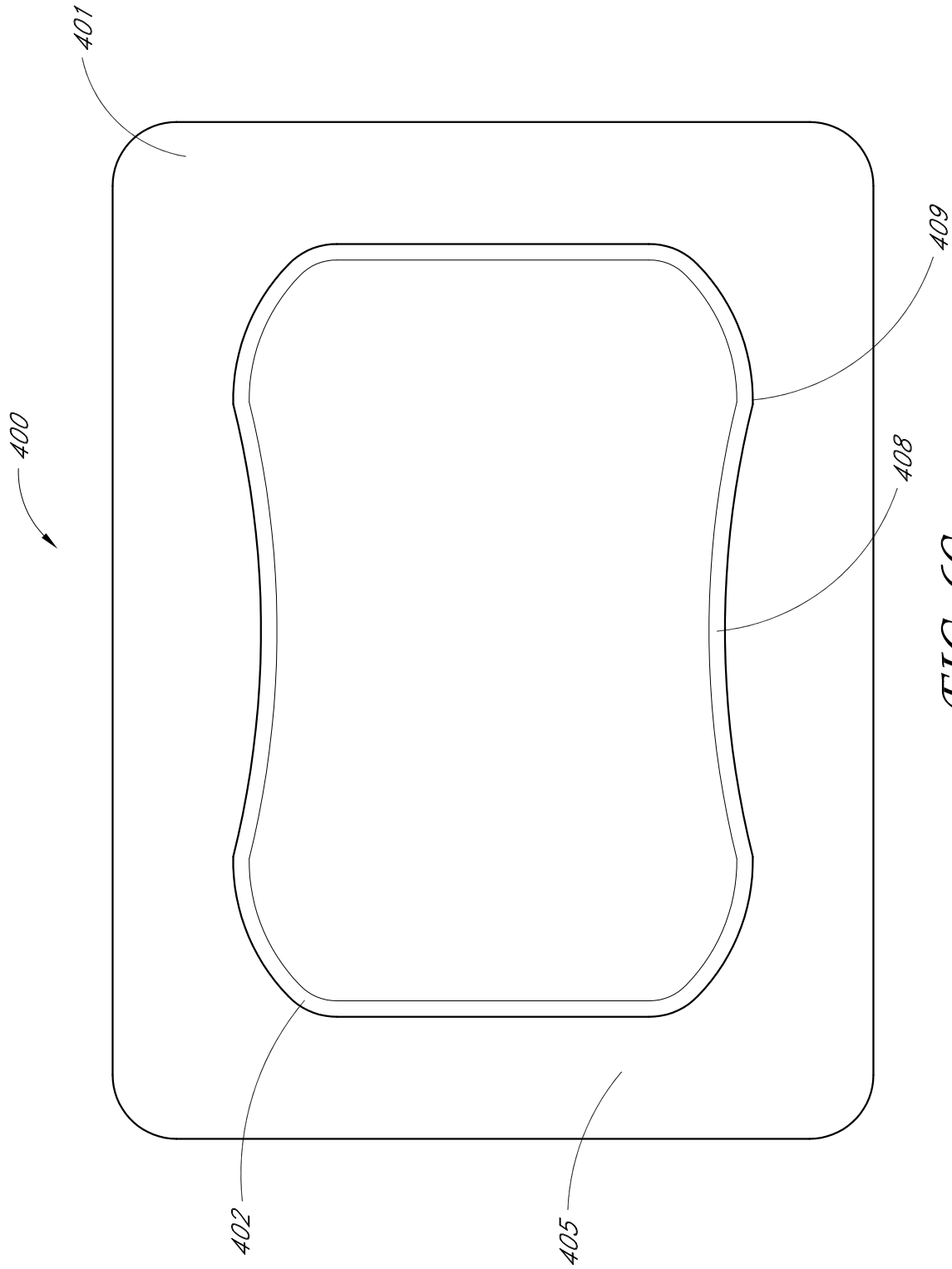

FIG. 6C

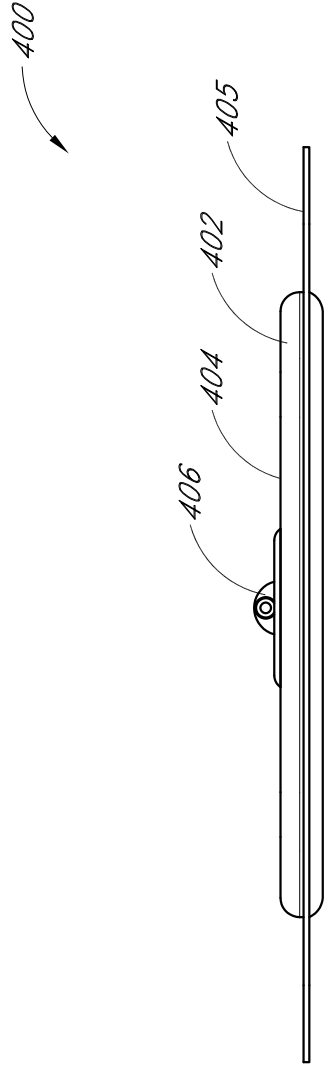

FIG. 6D

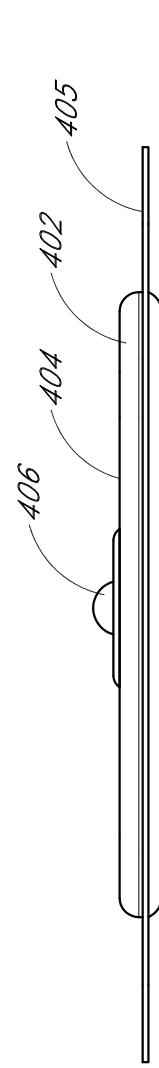

FIG. 6E

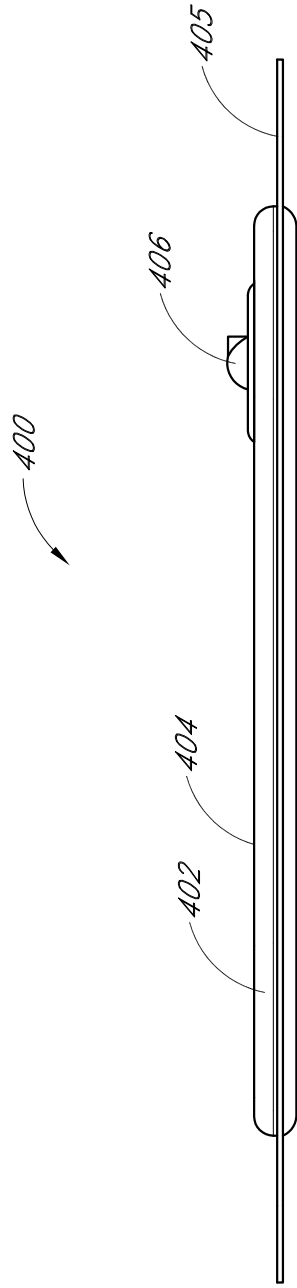

FIG. 6F

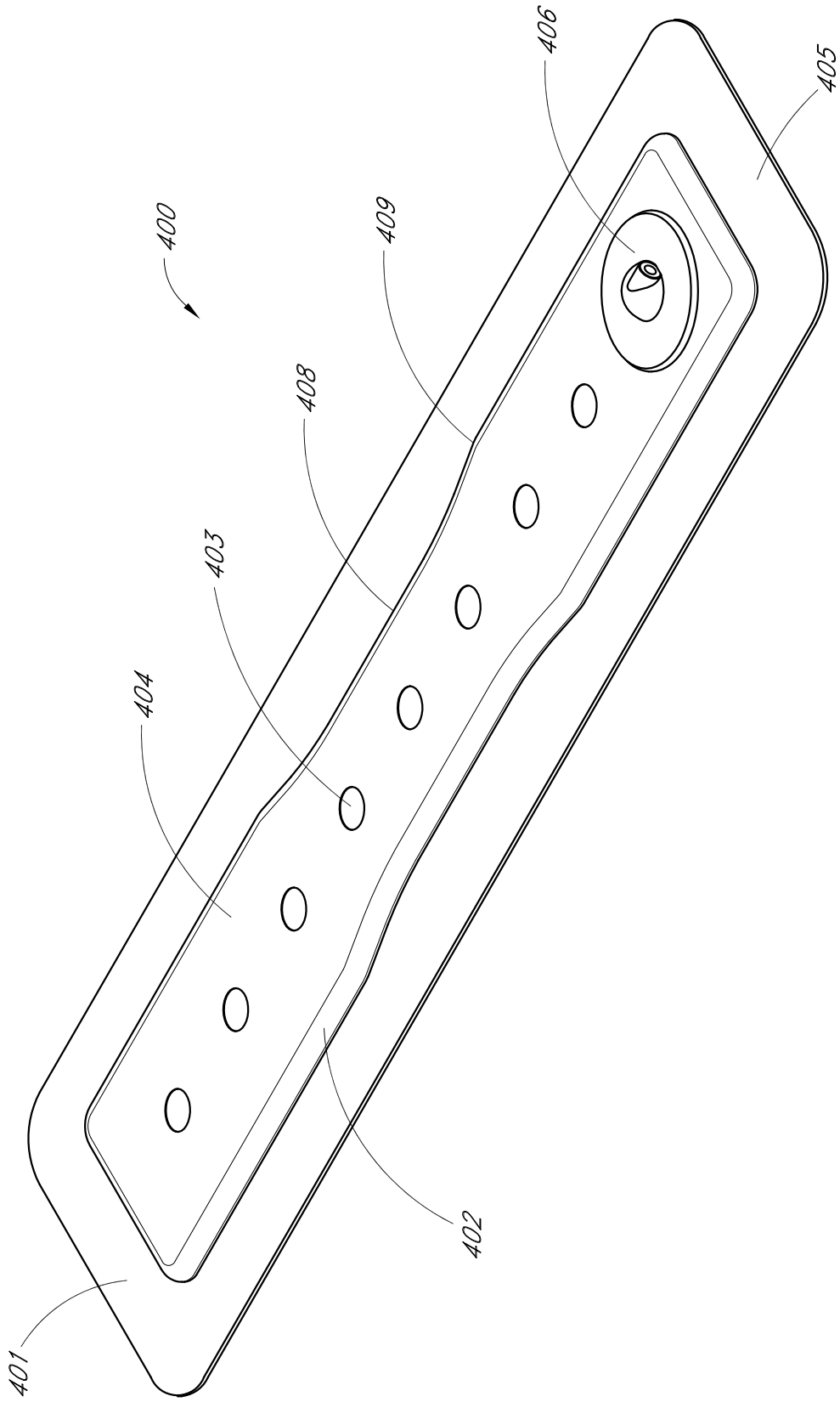

FIG. 7A

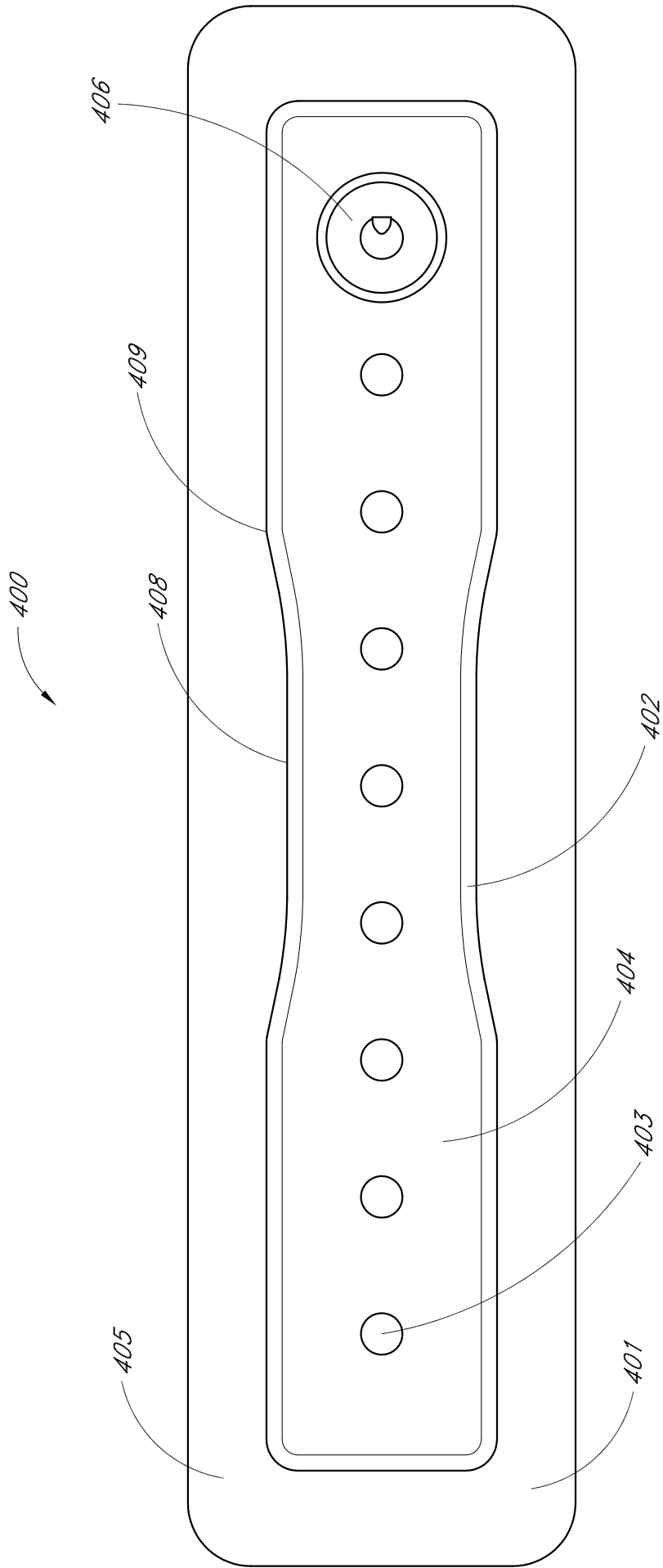

FIG. 7B

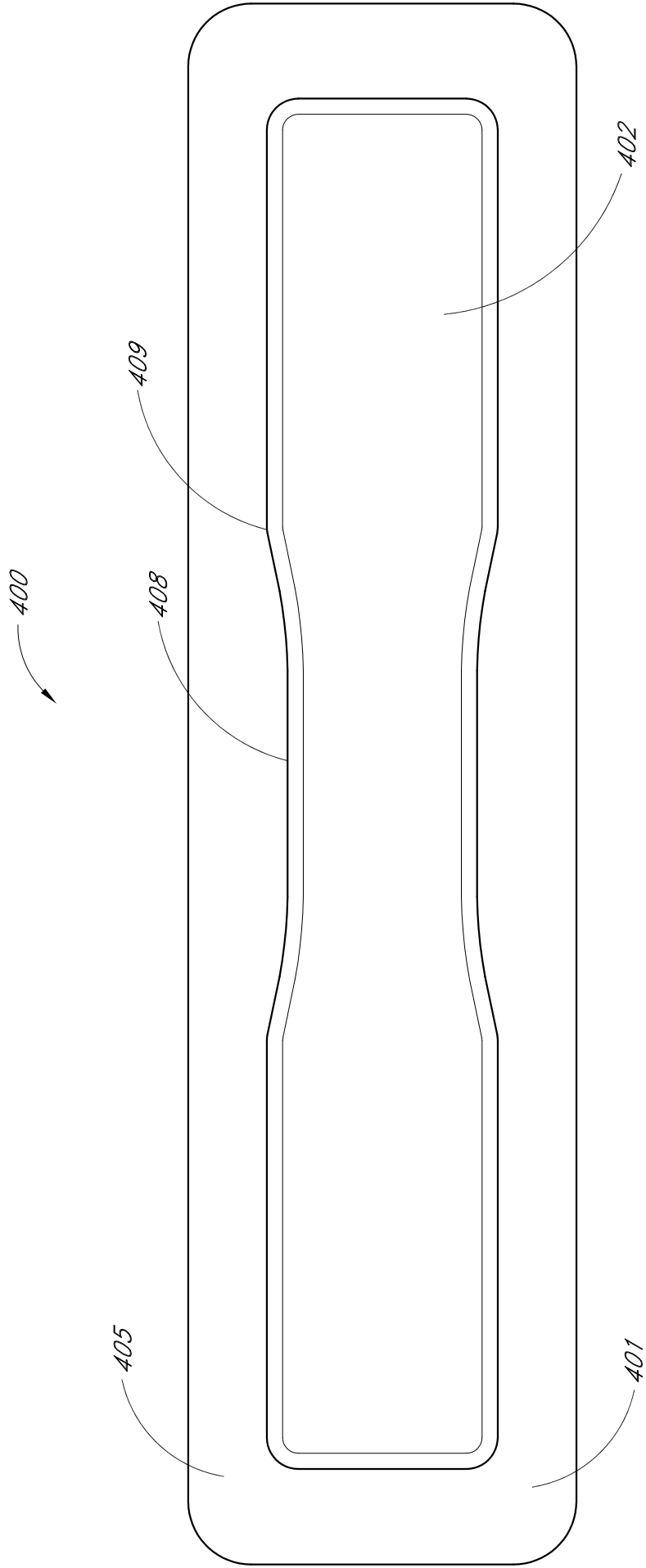

FIG. 7C

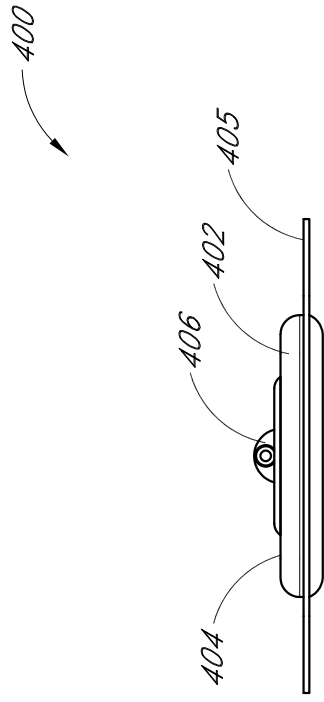

FIG. 7D

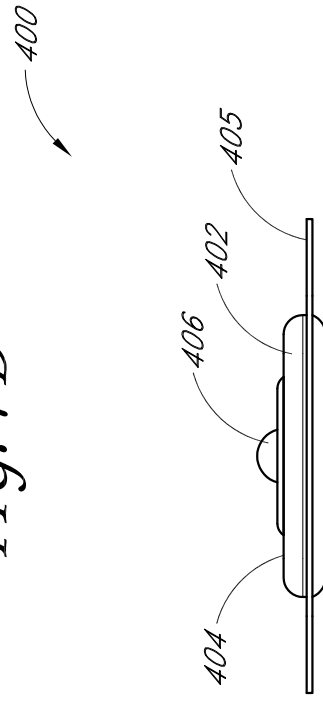

FIG. 7E

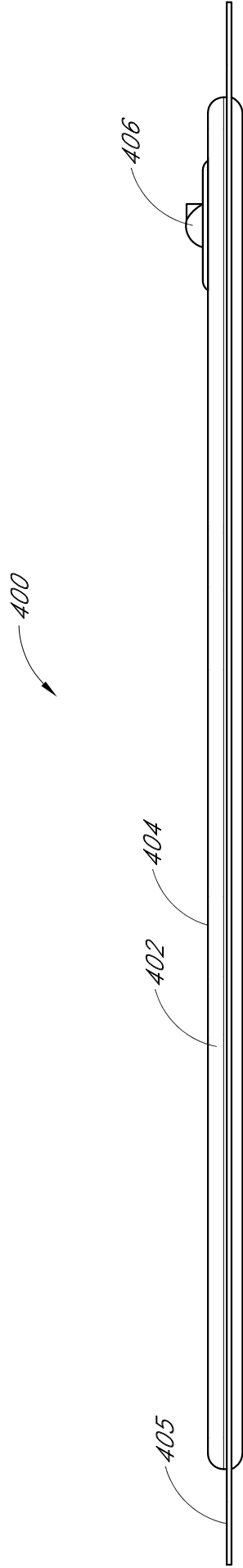

FIG. 7F

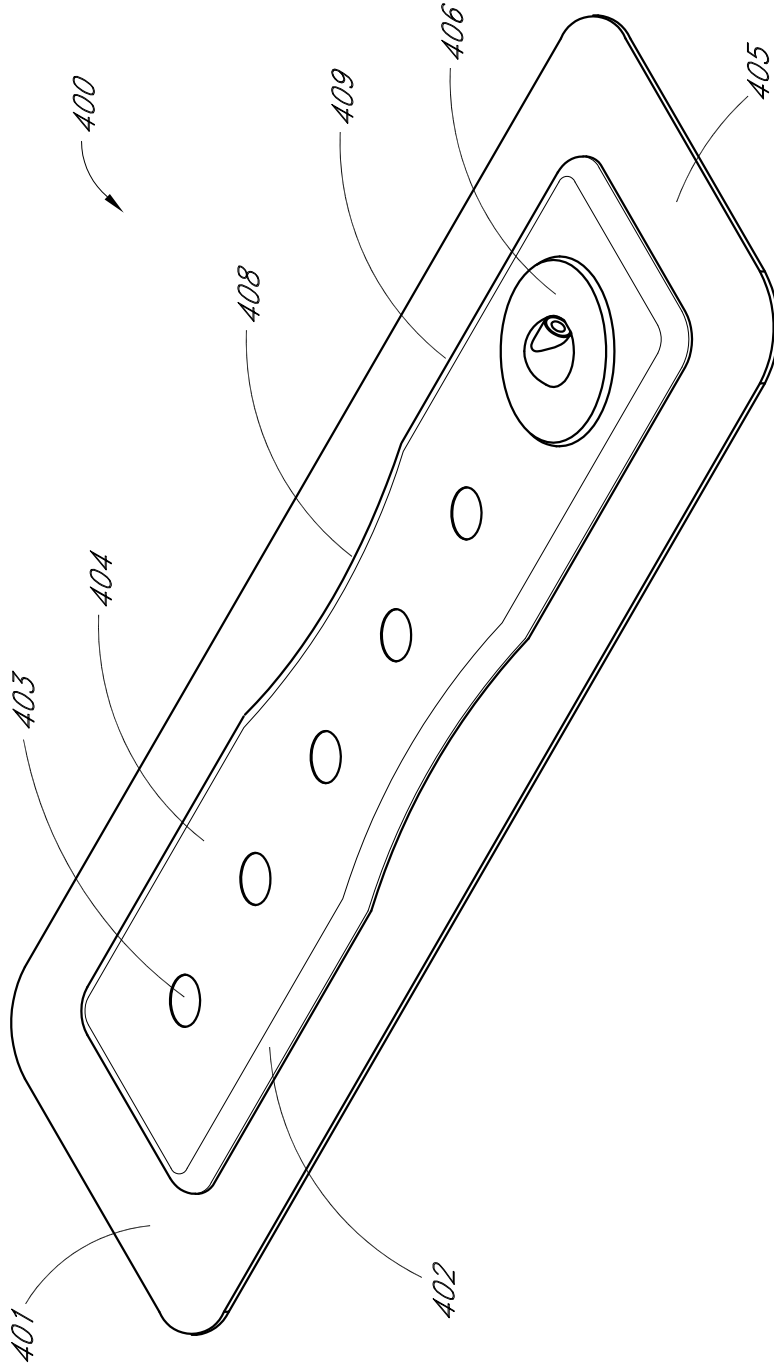

FIG. 8A

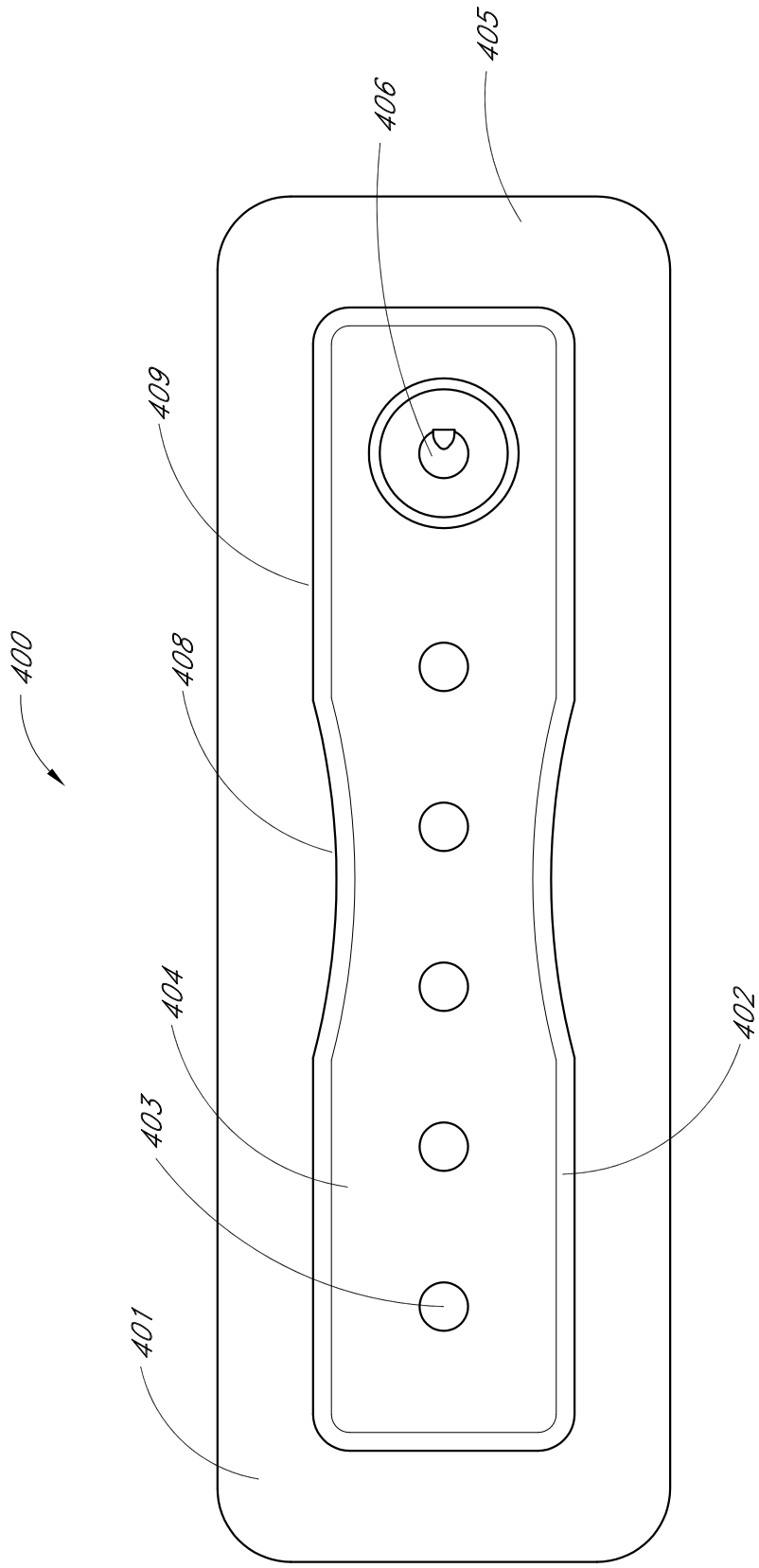

FIG. 8B

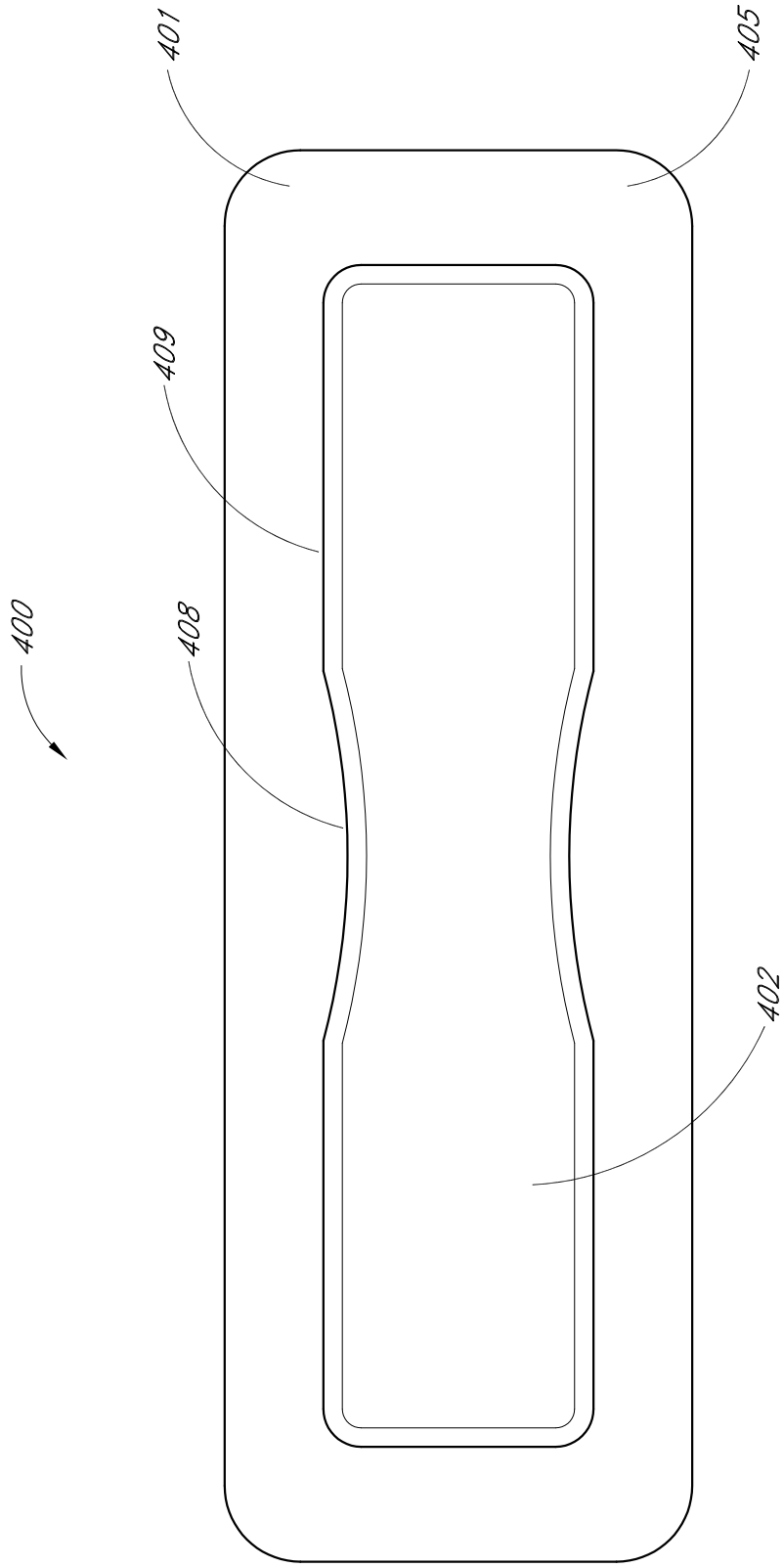

FIG. 8C

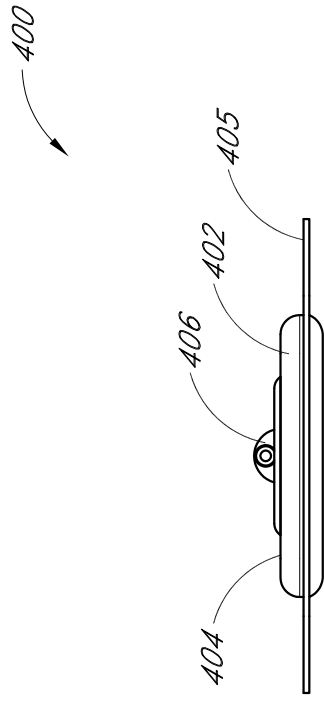

FIG. 8D

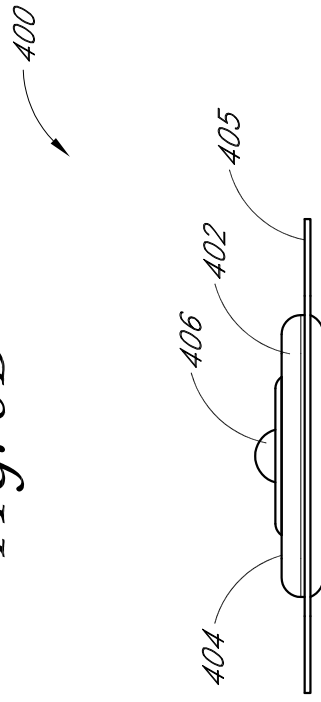

FIG. 8E

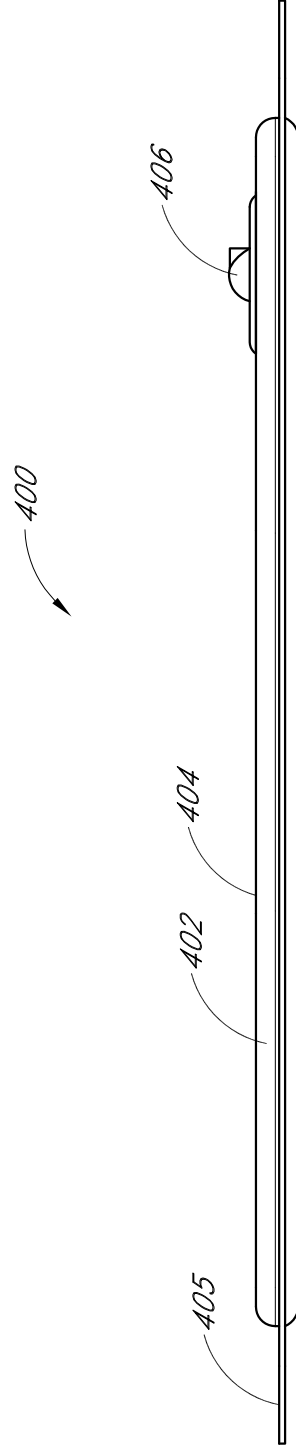

FIG. 8F

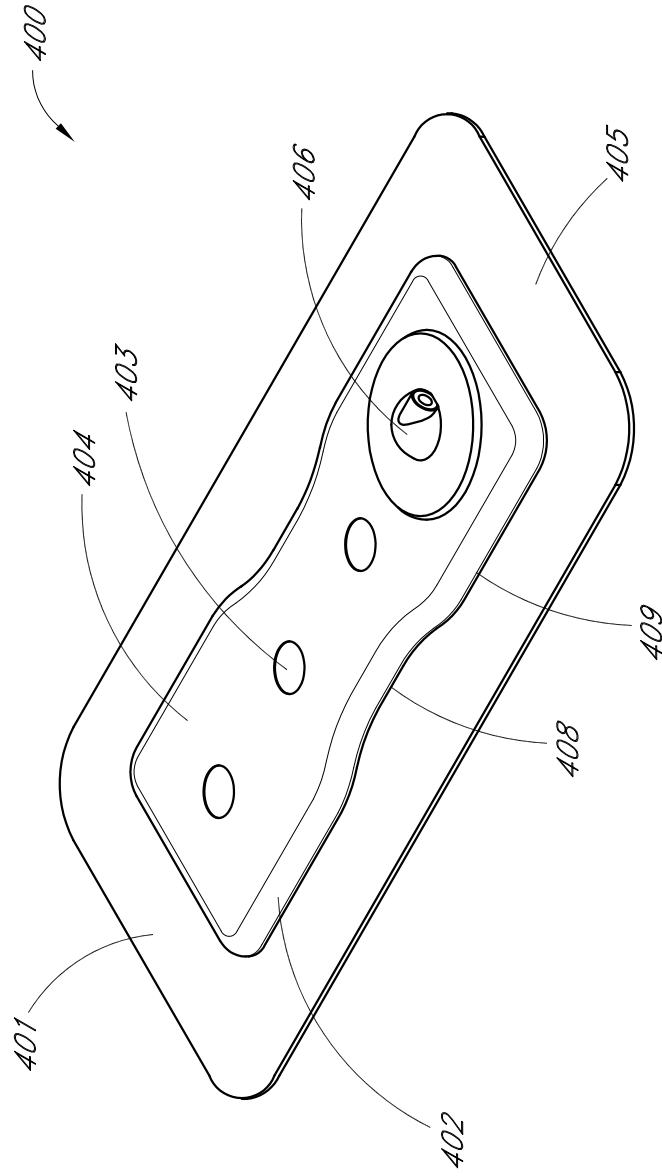

FIG. 9A

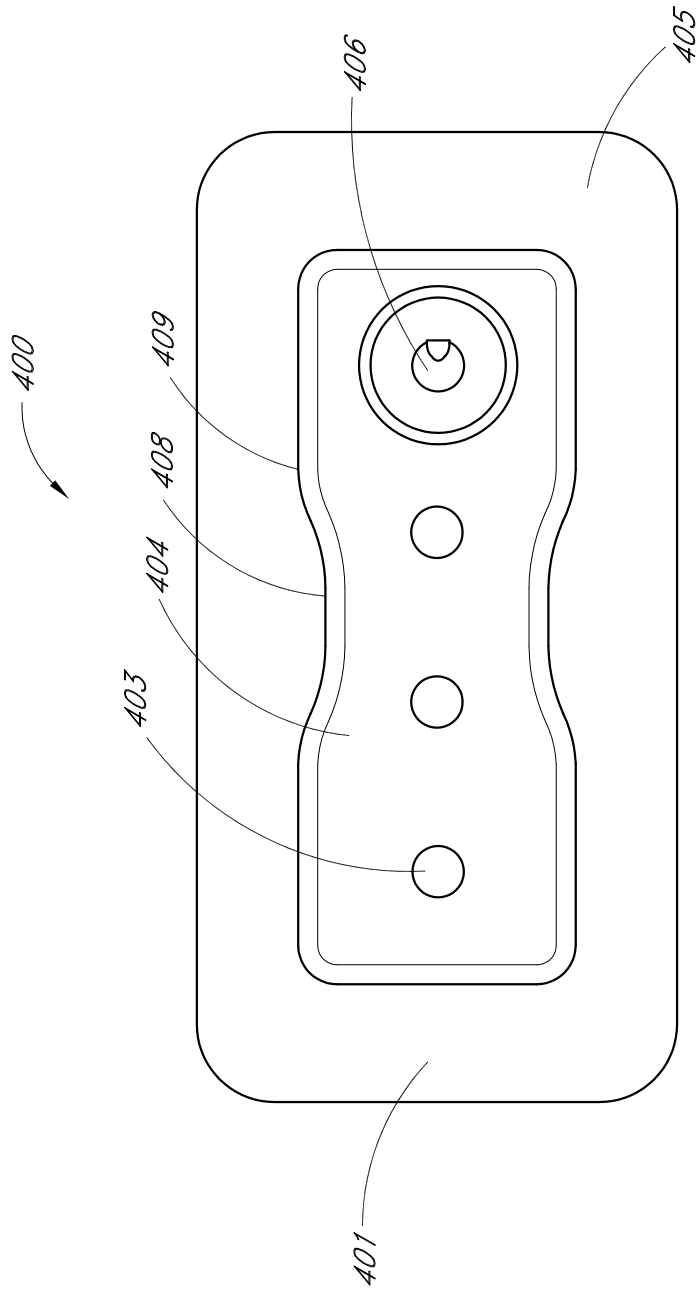

FIG. 9B

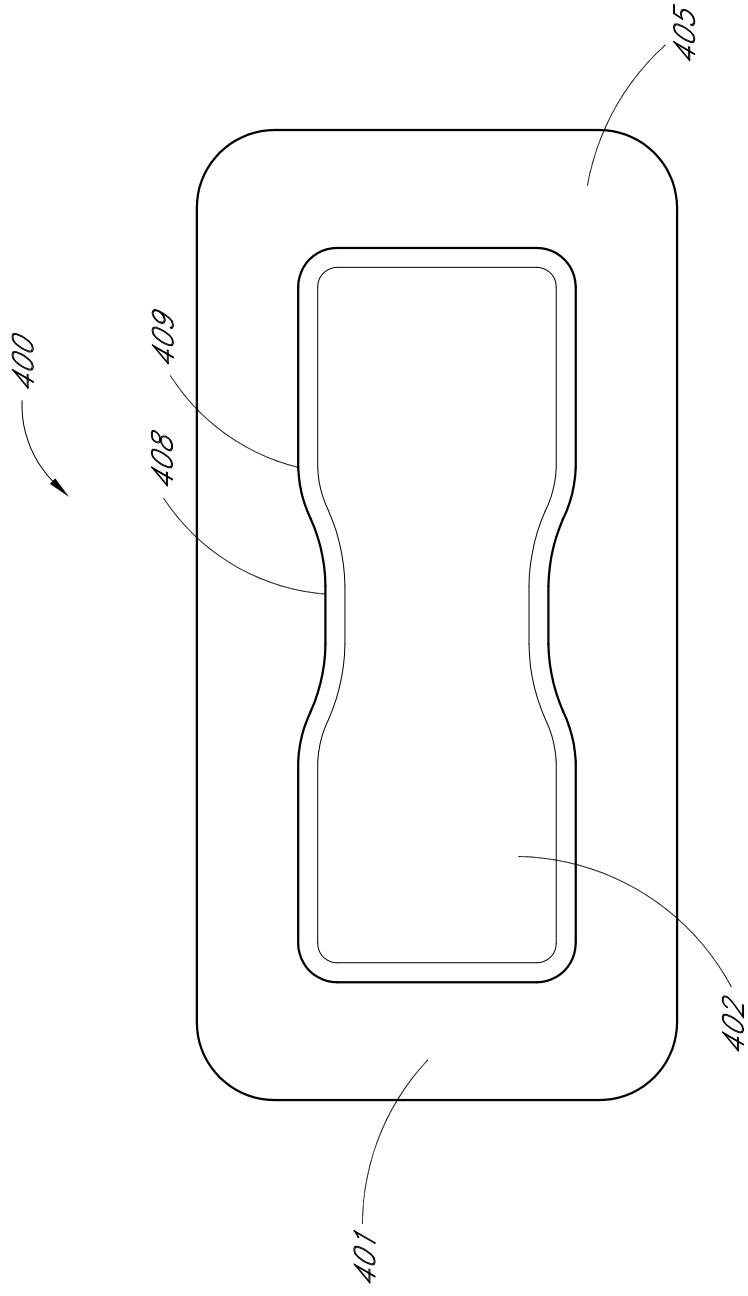

FIG. 9C

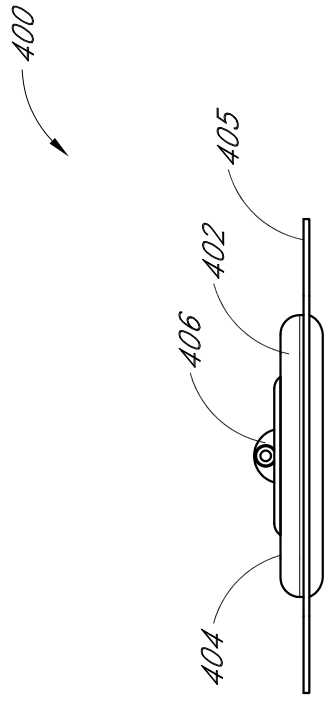

FIG. 9D

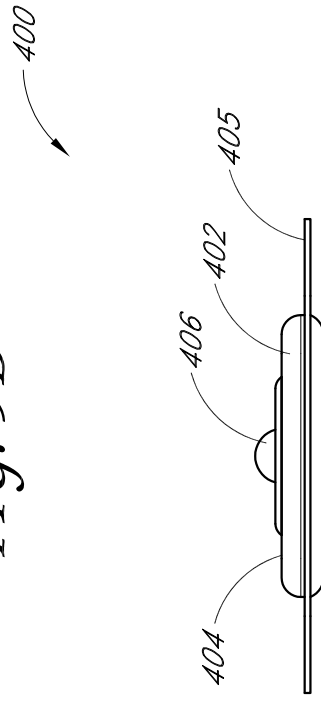

FIG. 9E

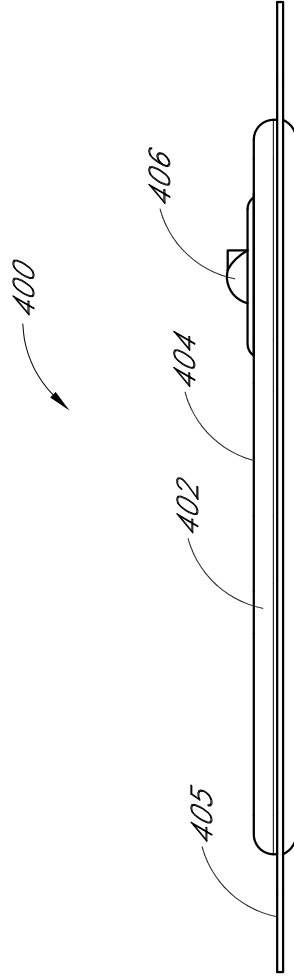

FIG. 9F

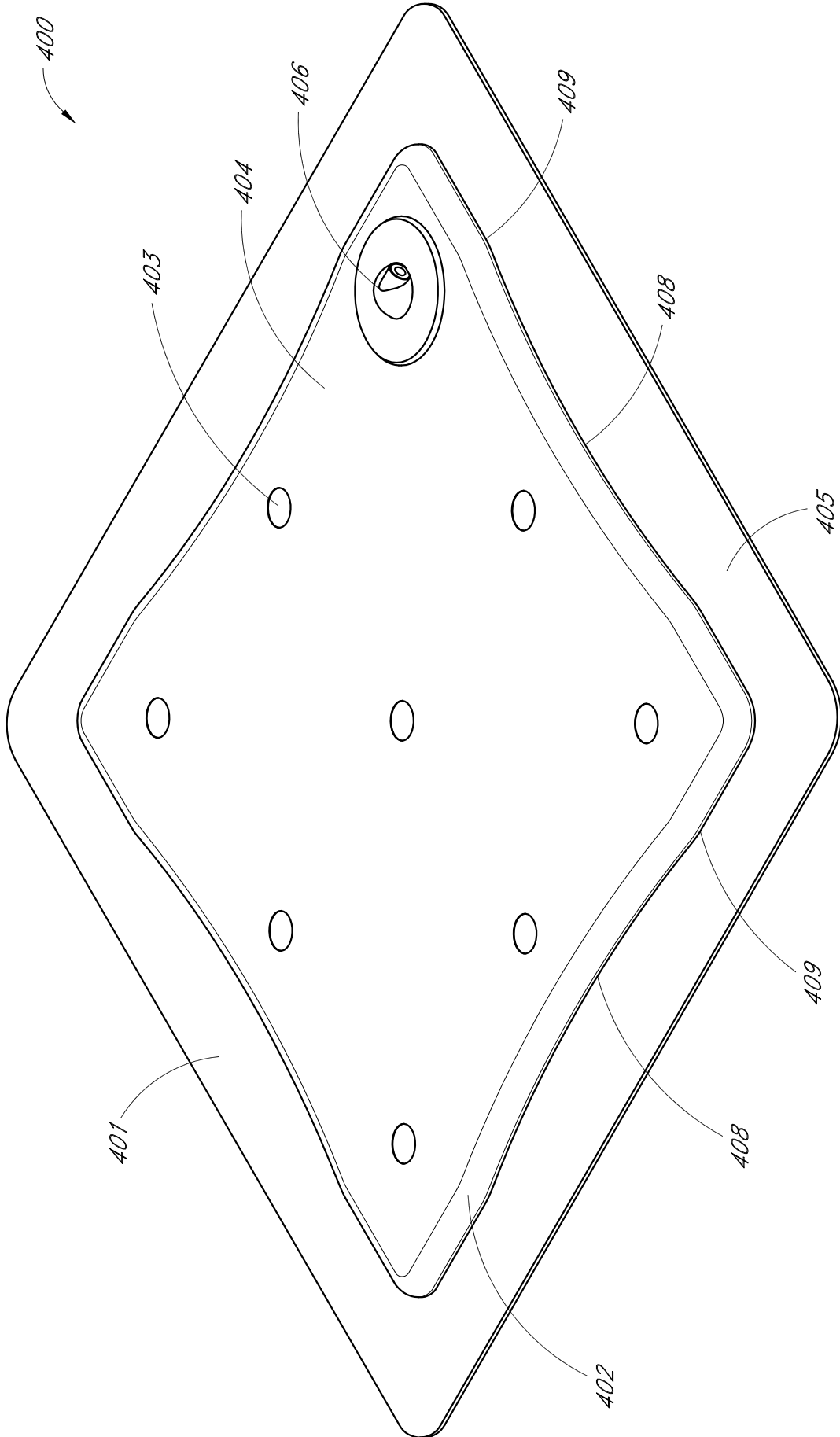

FIG. 10A

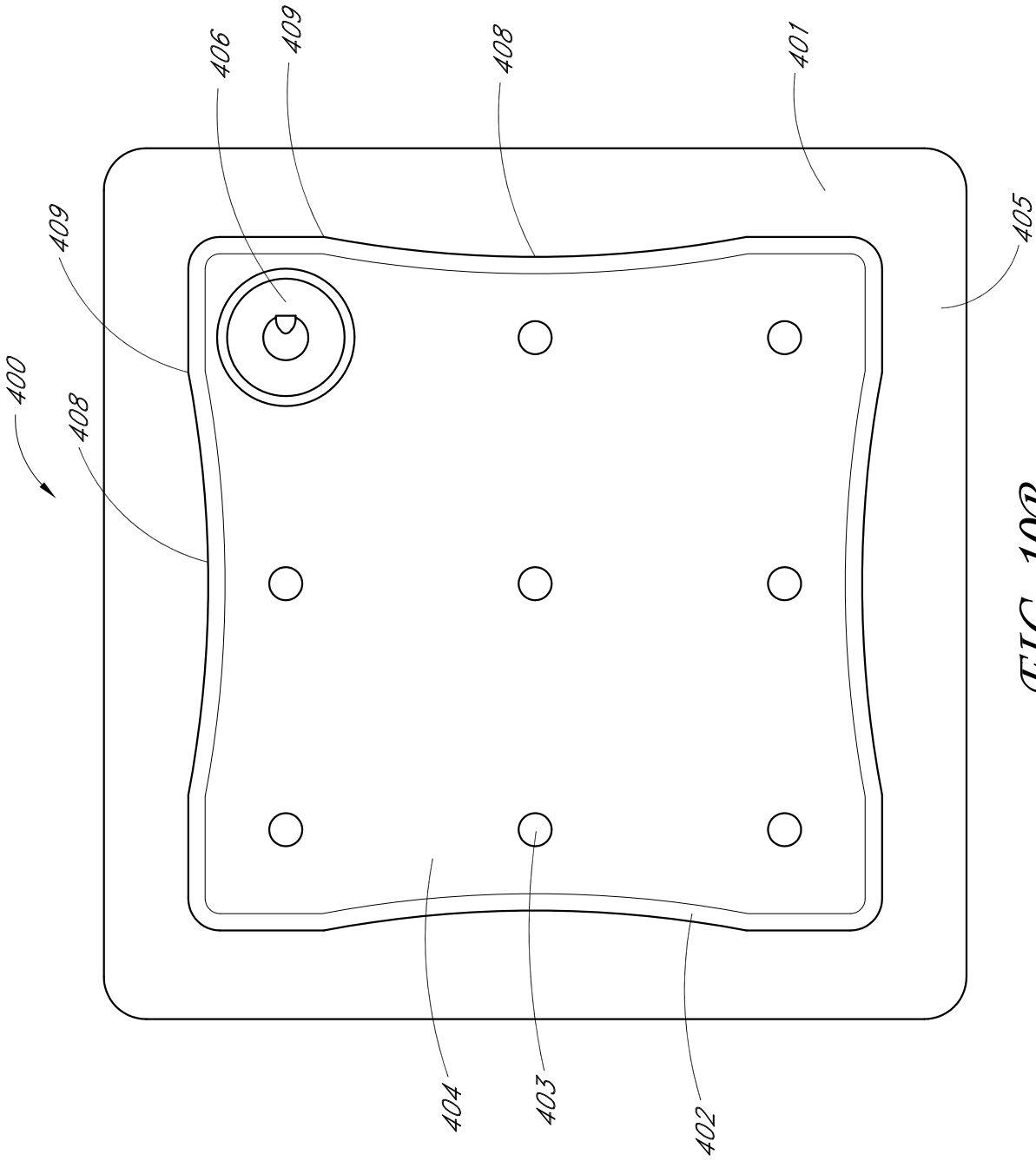

FIG. 10B

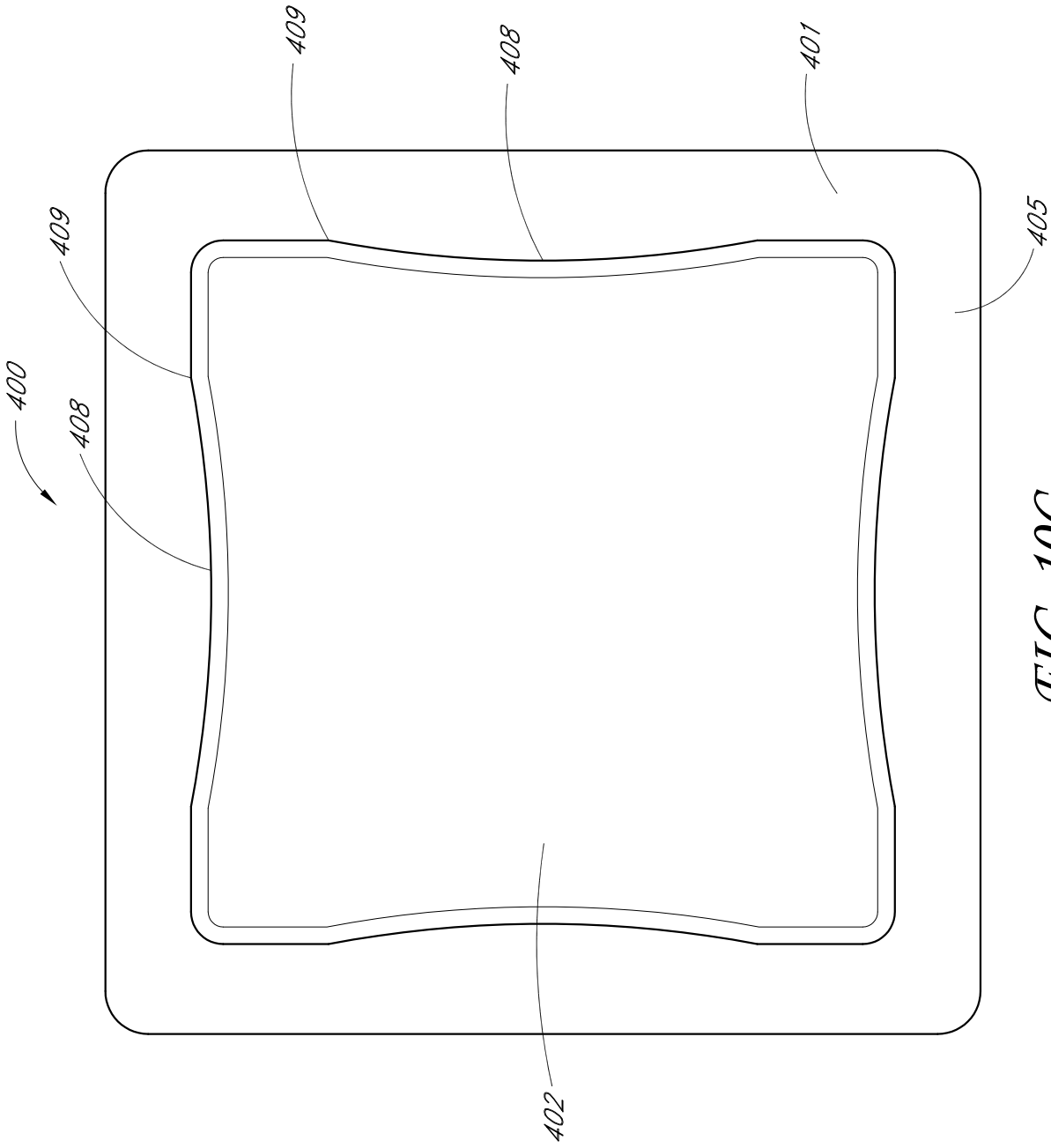

FIG. 10C

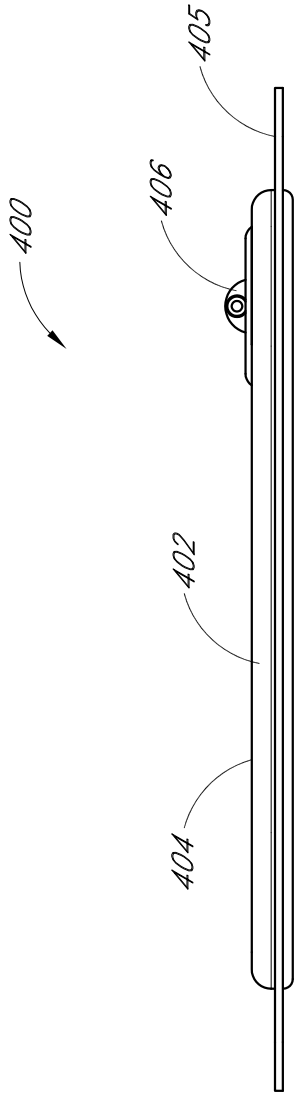

FIG. 10D

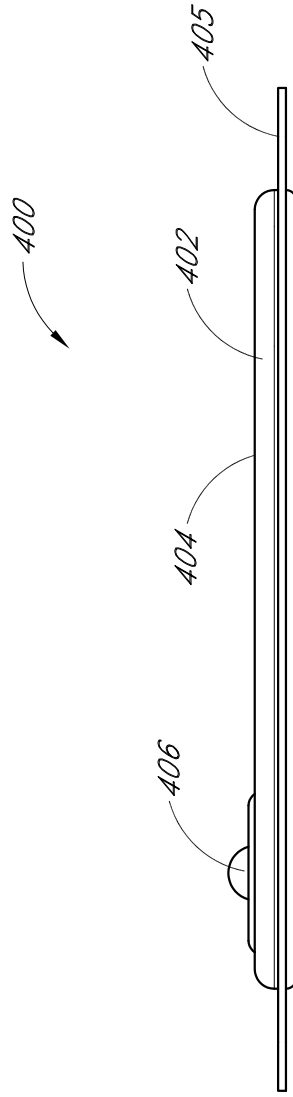

FIG. 10E

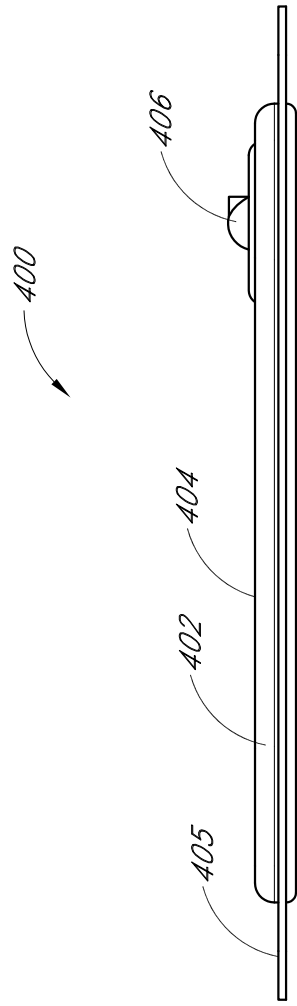

FIG. 10F

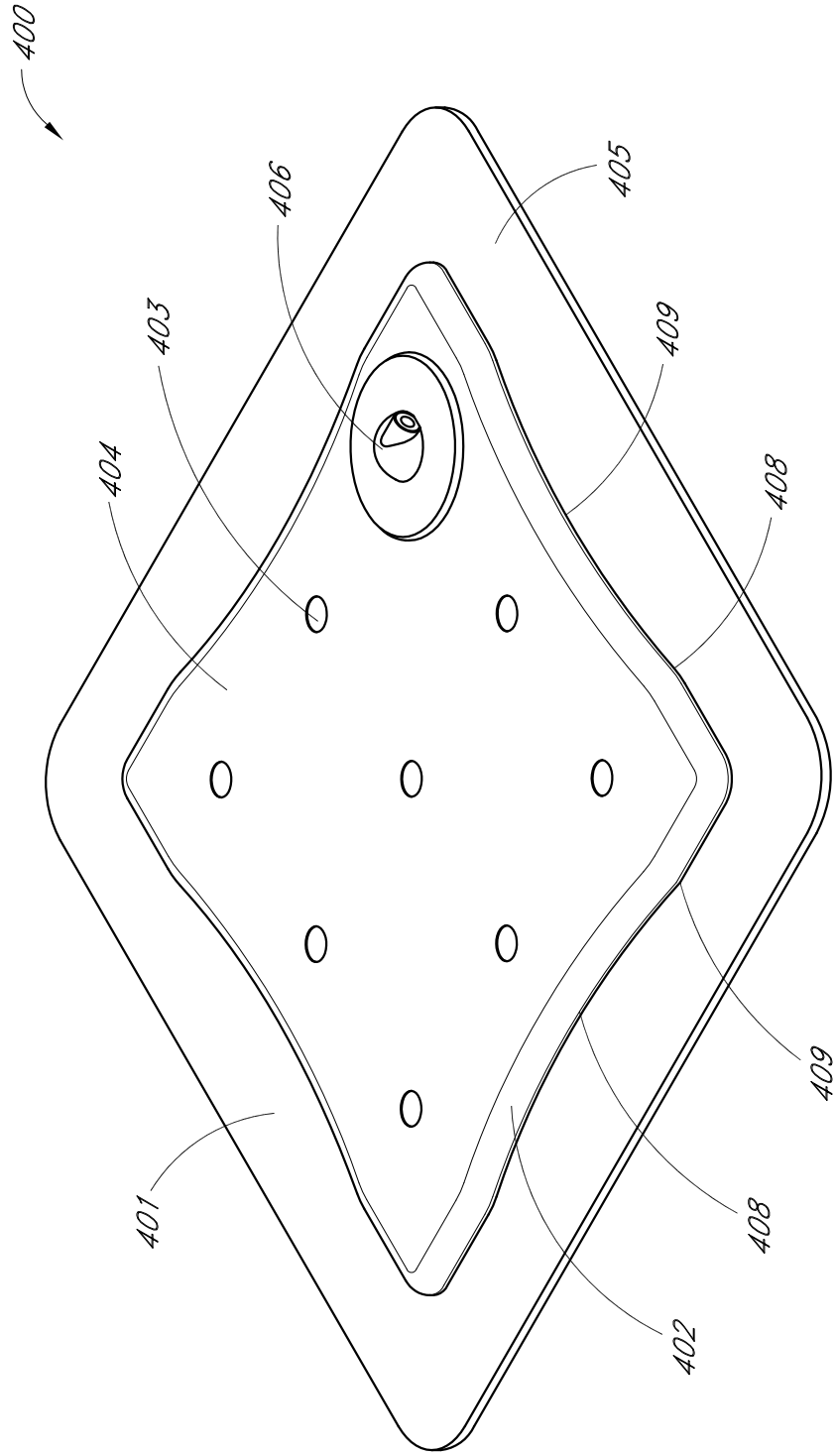

FIG. 11A

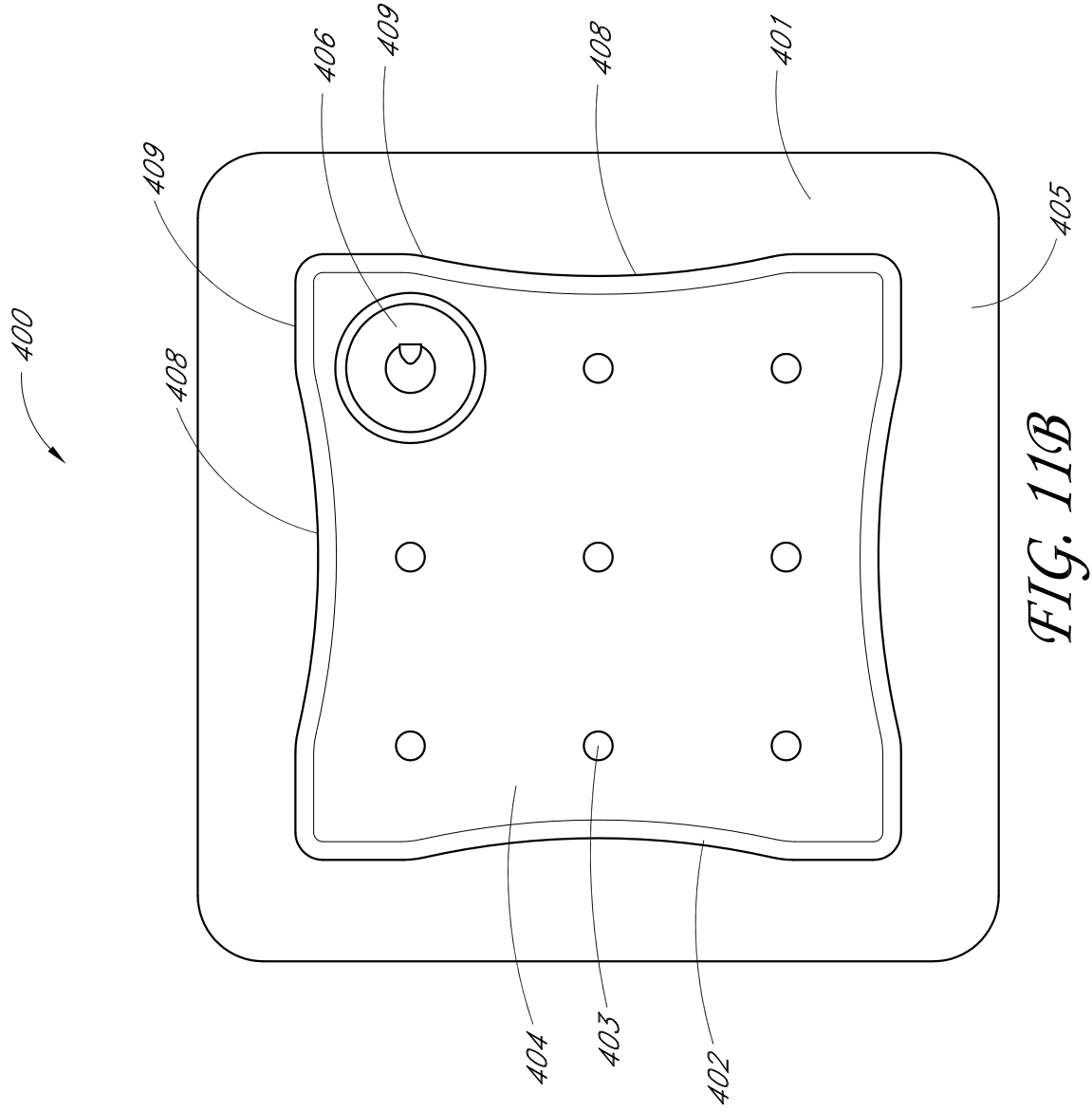

FIG. 11B

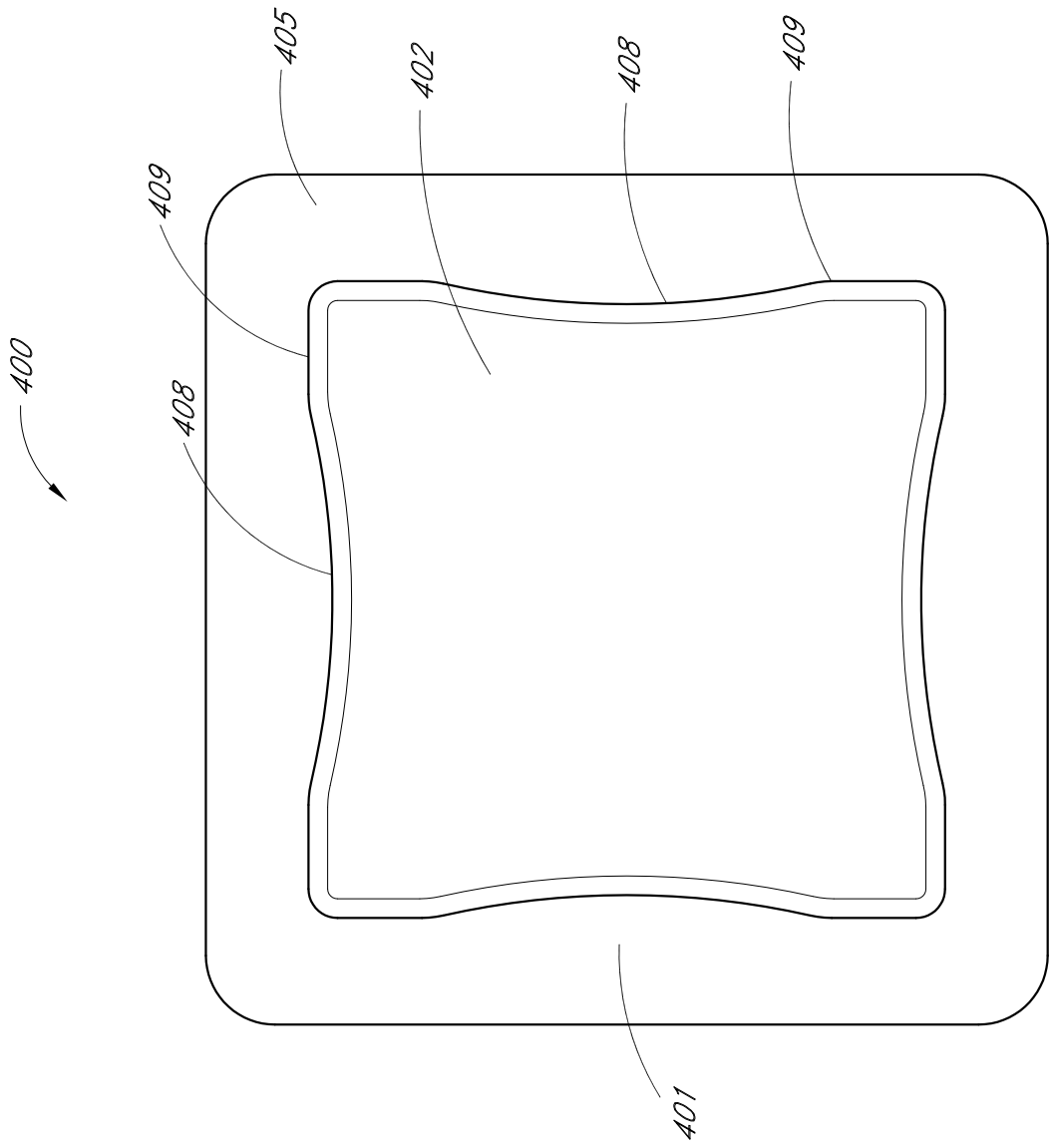

FIG. 11C

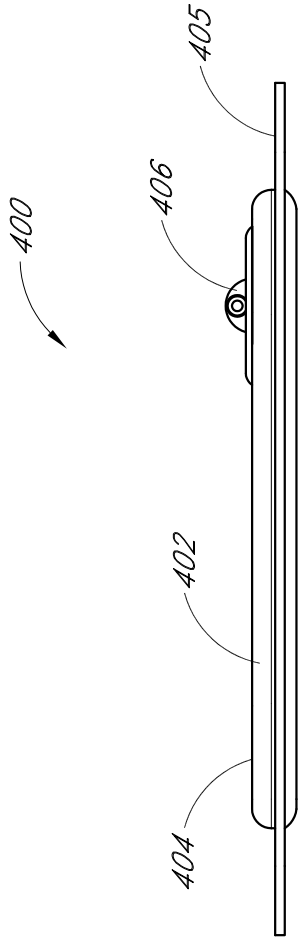

FIG. 11D

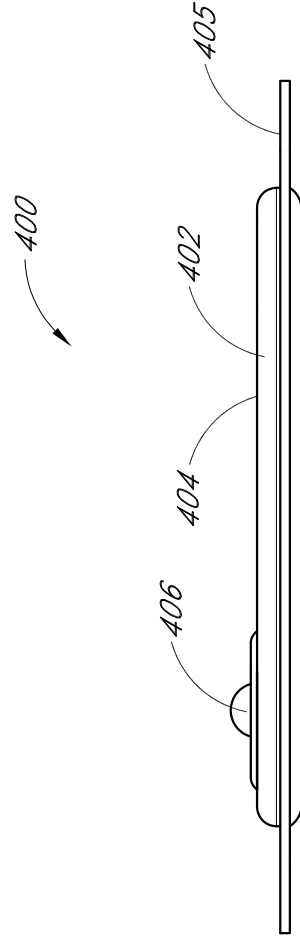

FIG. 11E

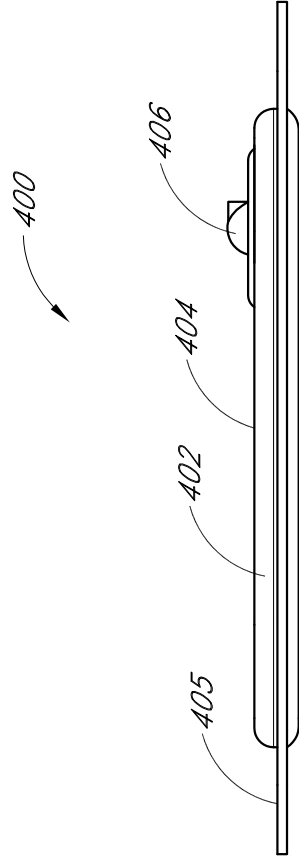

FIG. 11F

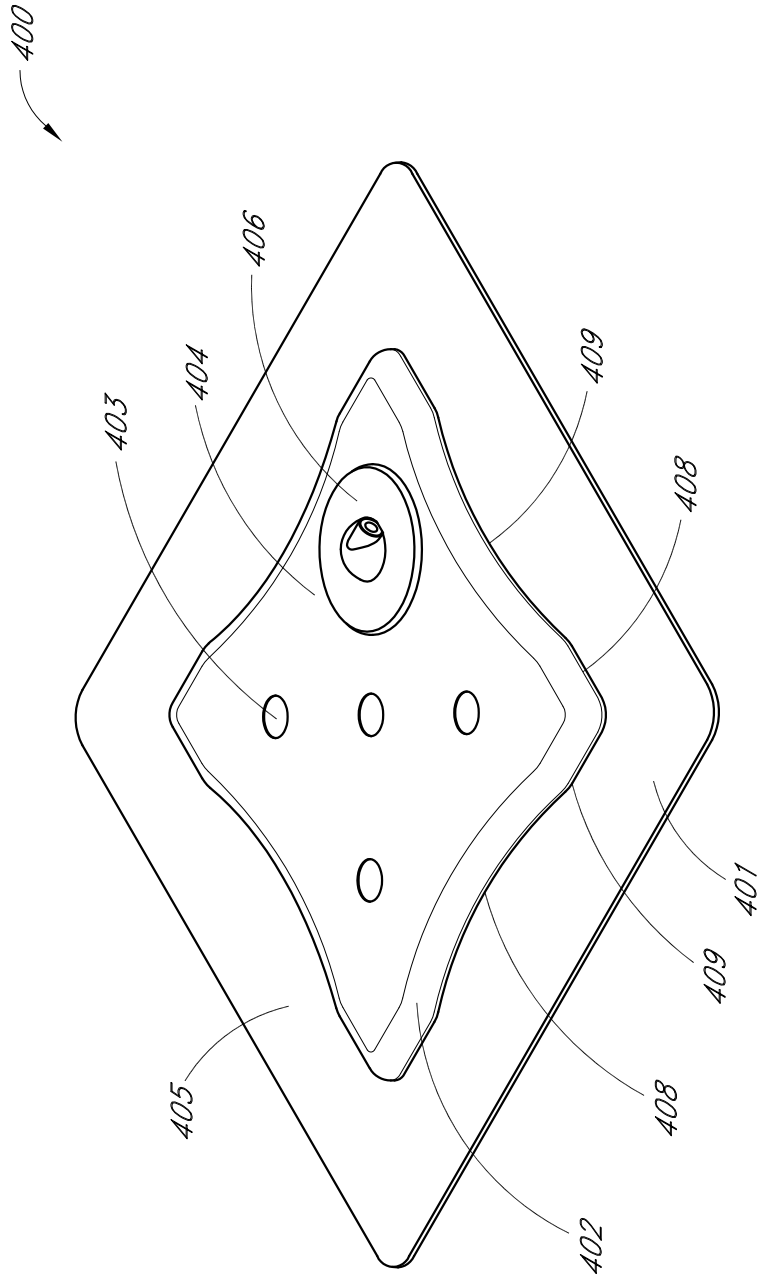

FIG. 12A

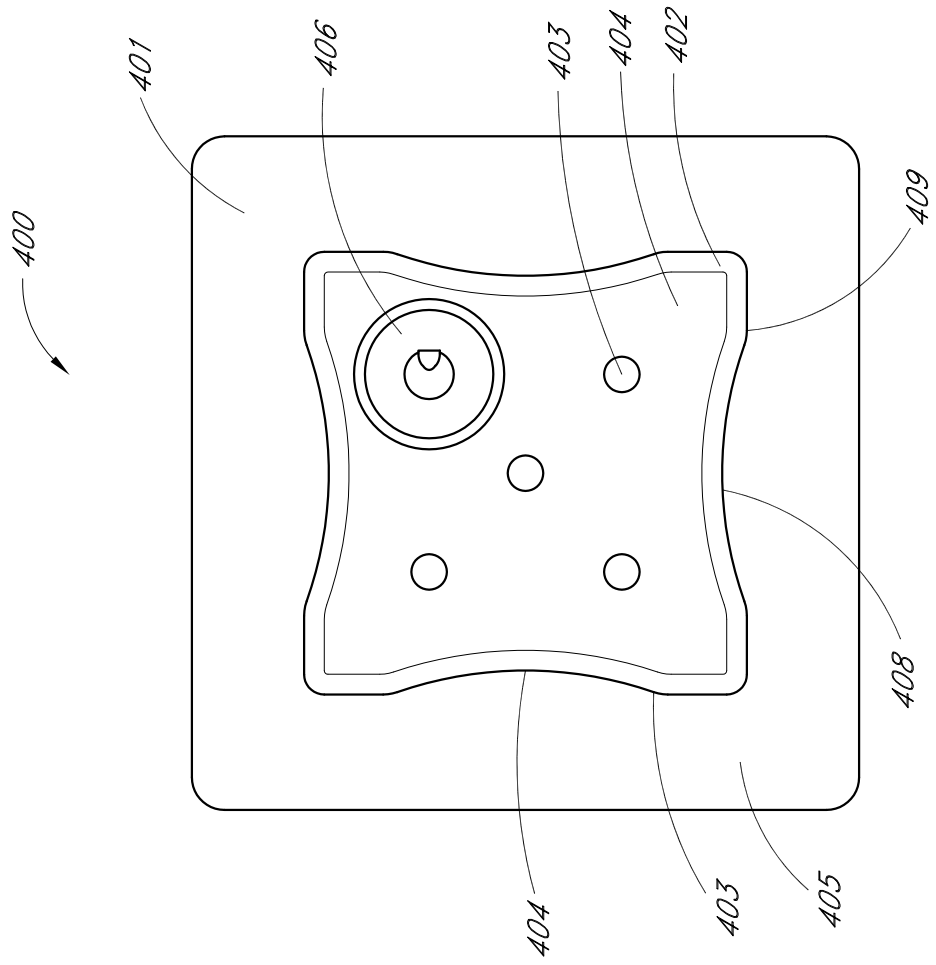

FIG. 12B

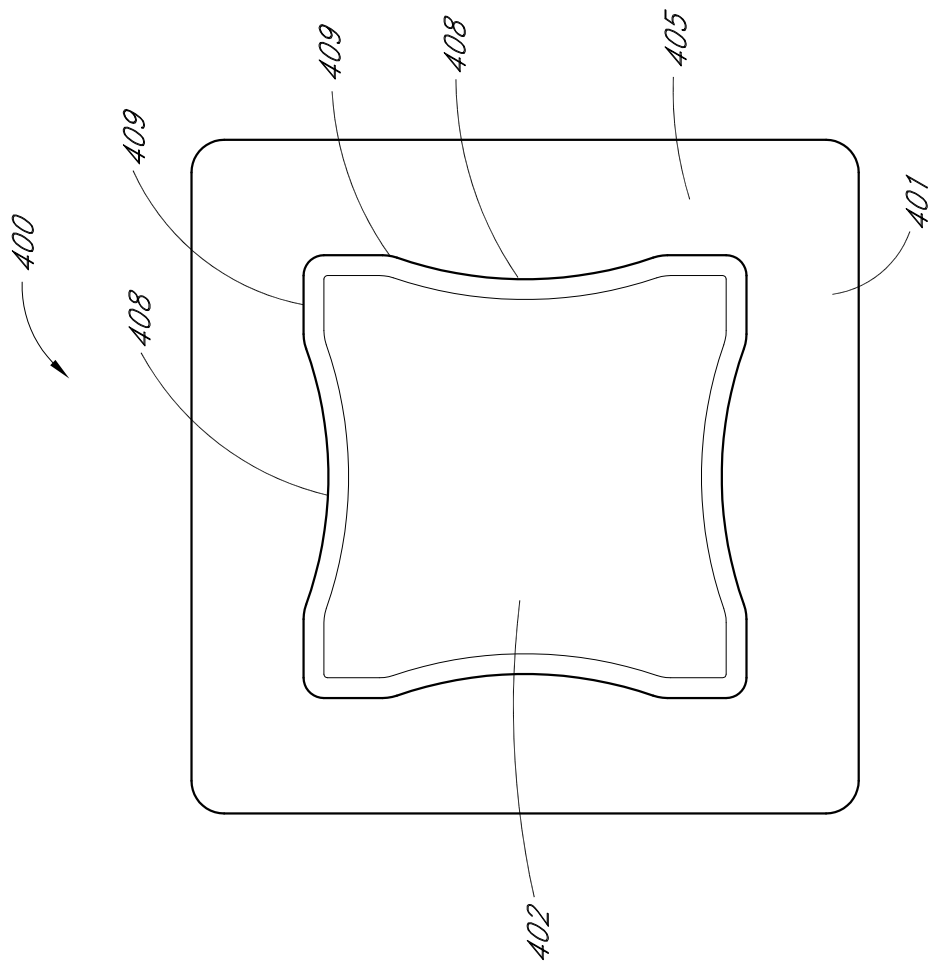

FIG. 12C

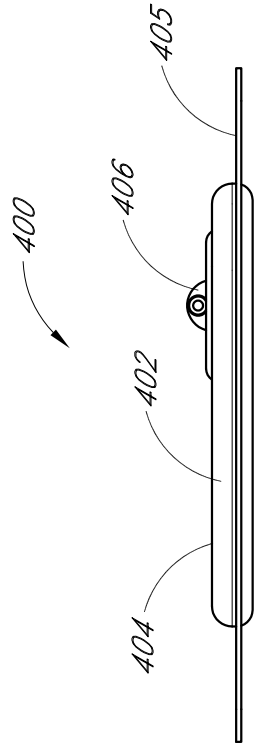

FIG. 12D

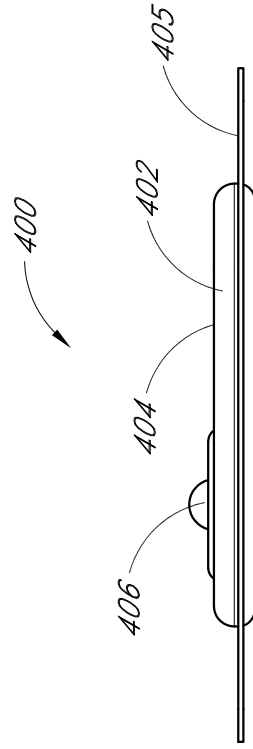

FIG. 12E

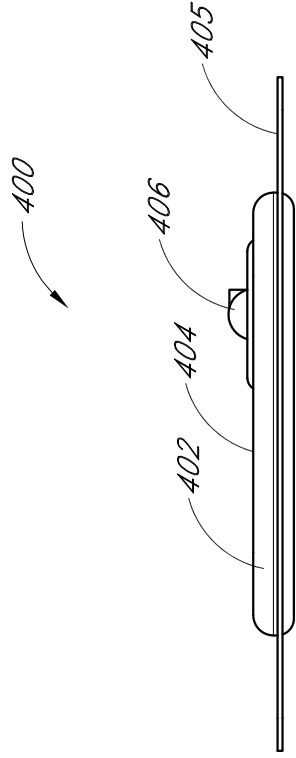

FIG. 12F

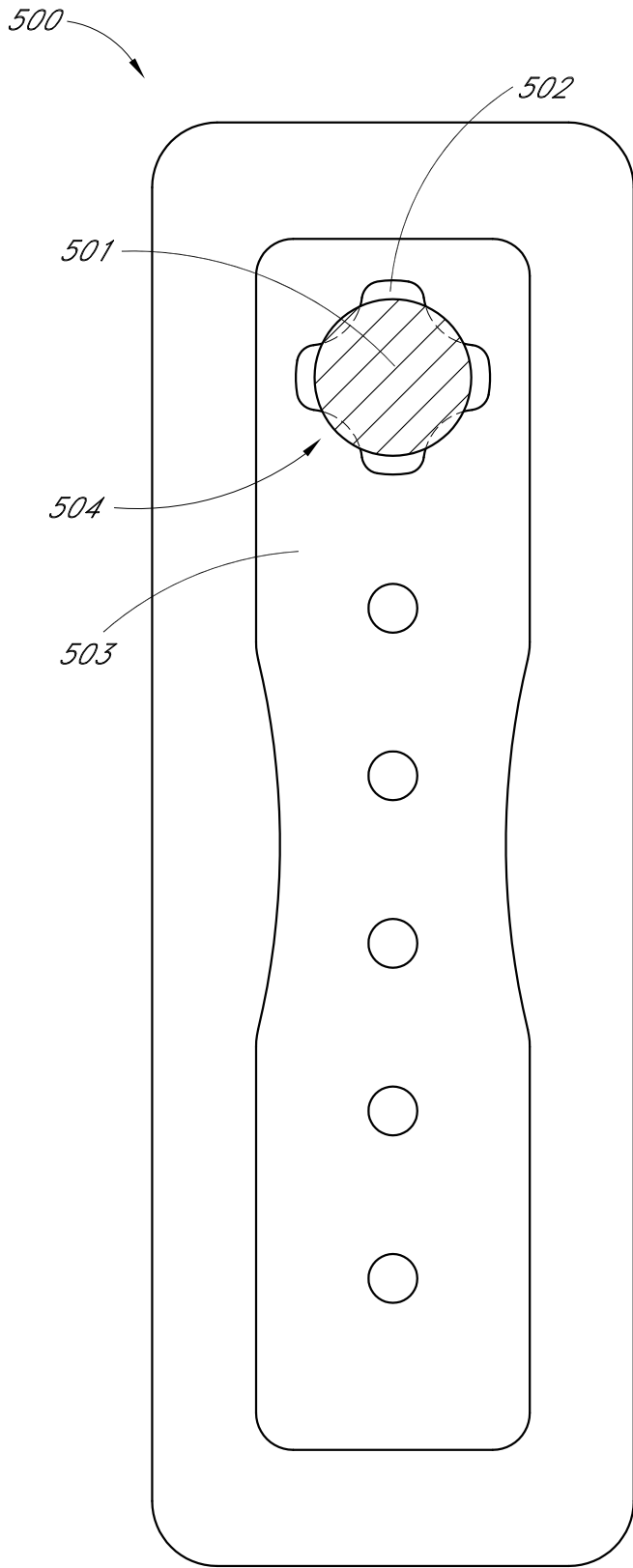

FIG. 13A

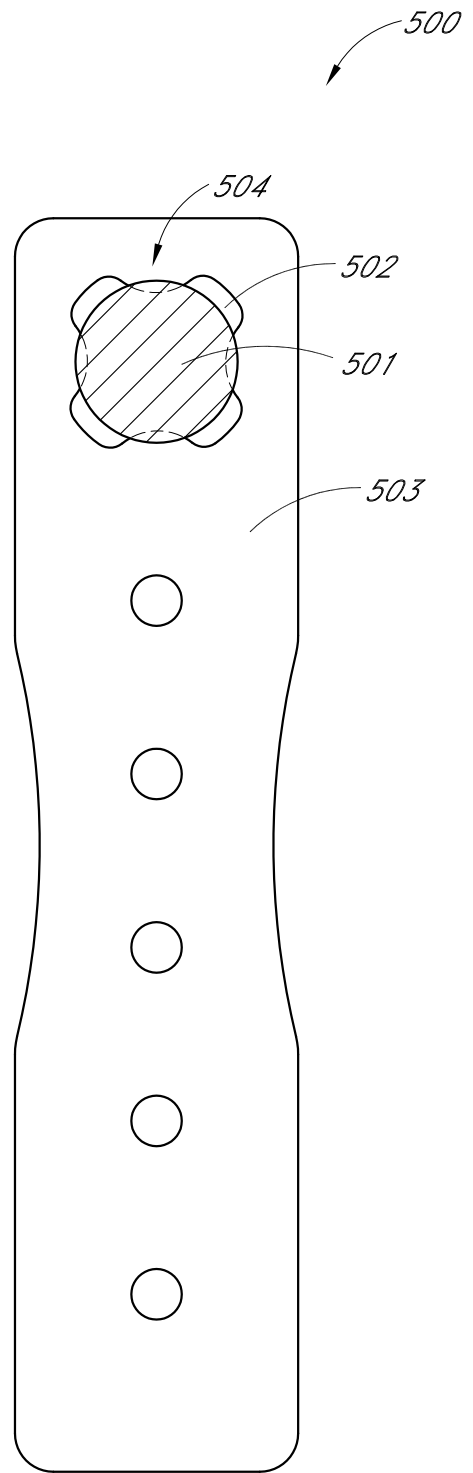

FIG. 13B

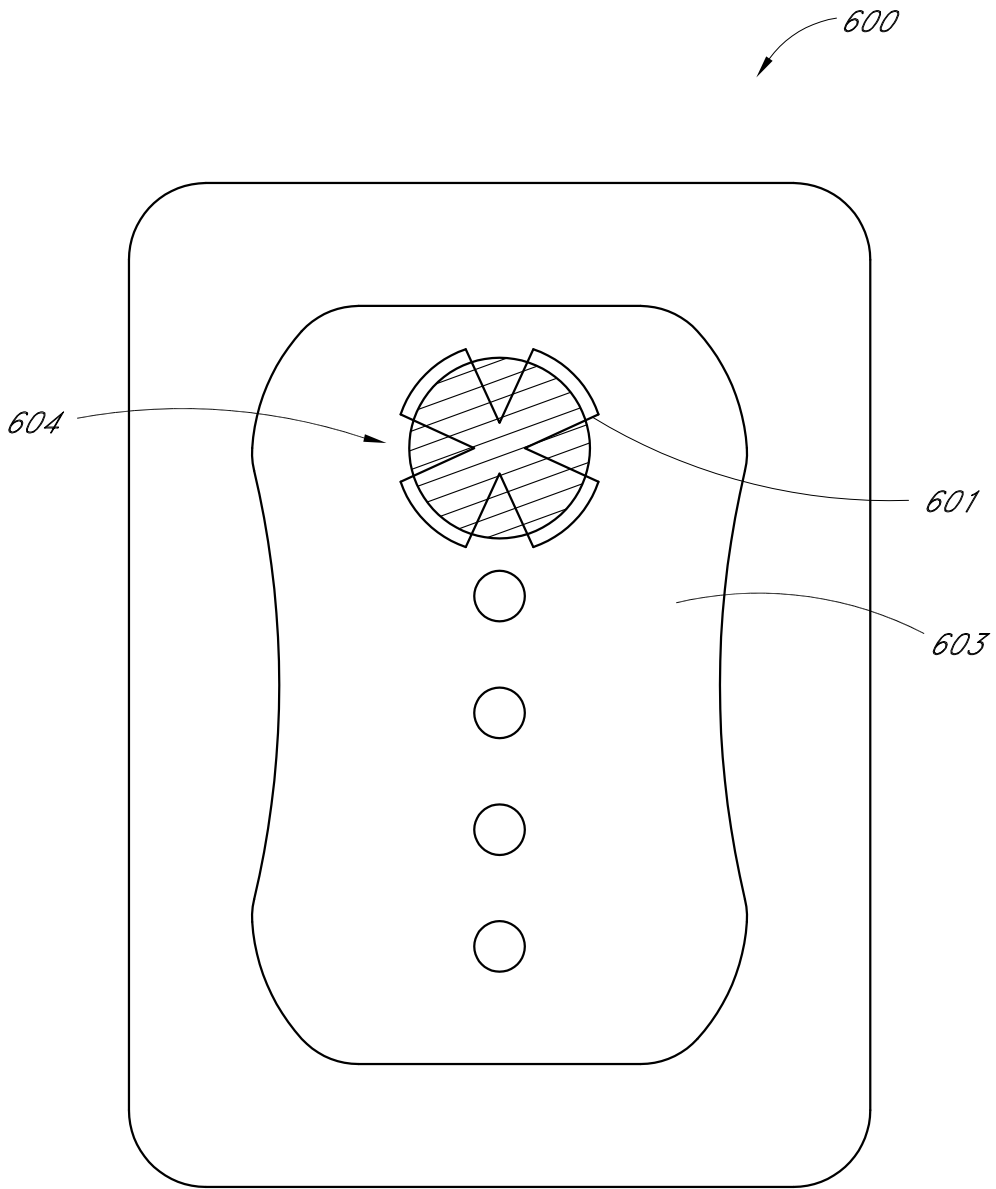

FIG. 14

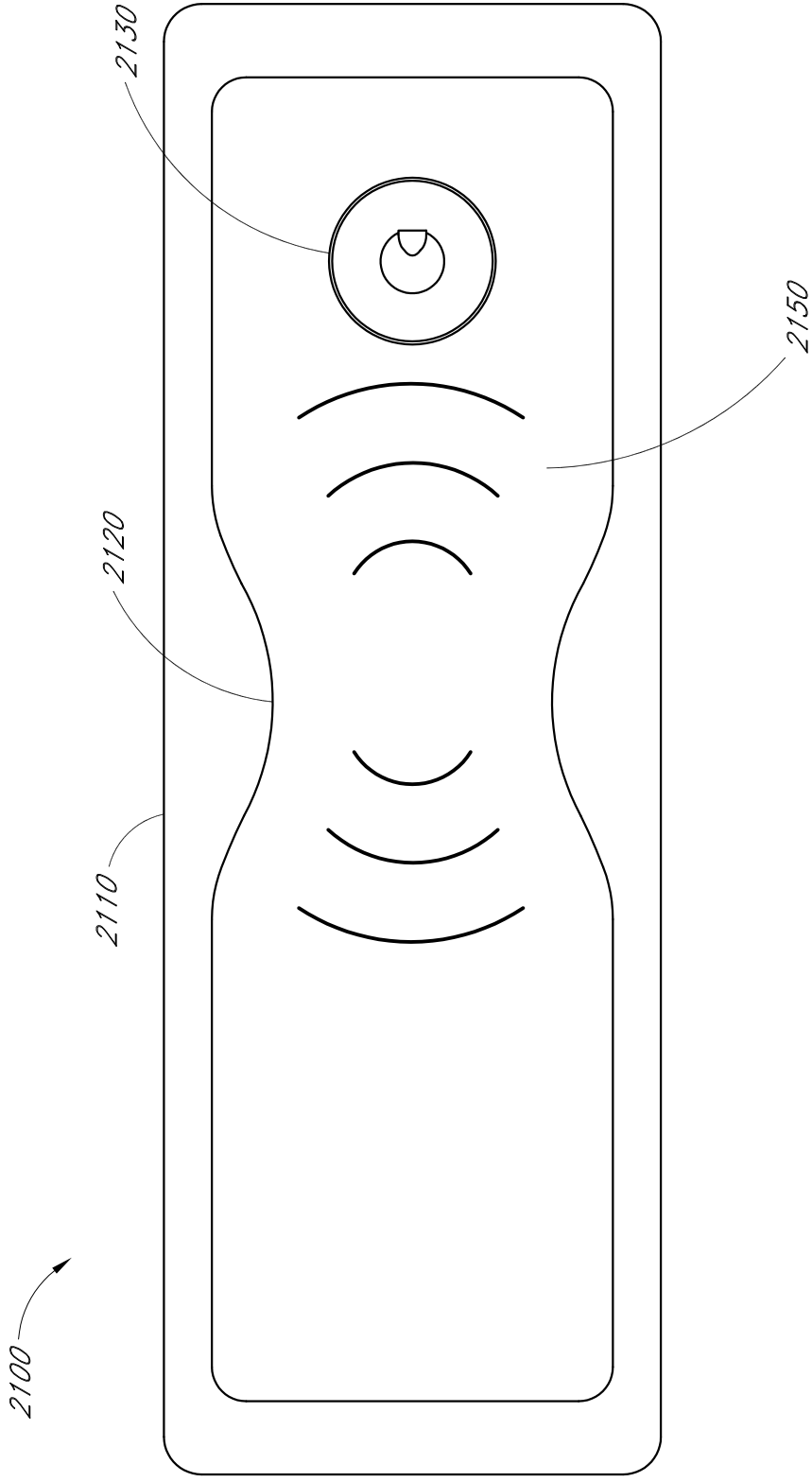

FIG. 15A

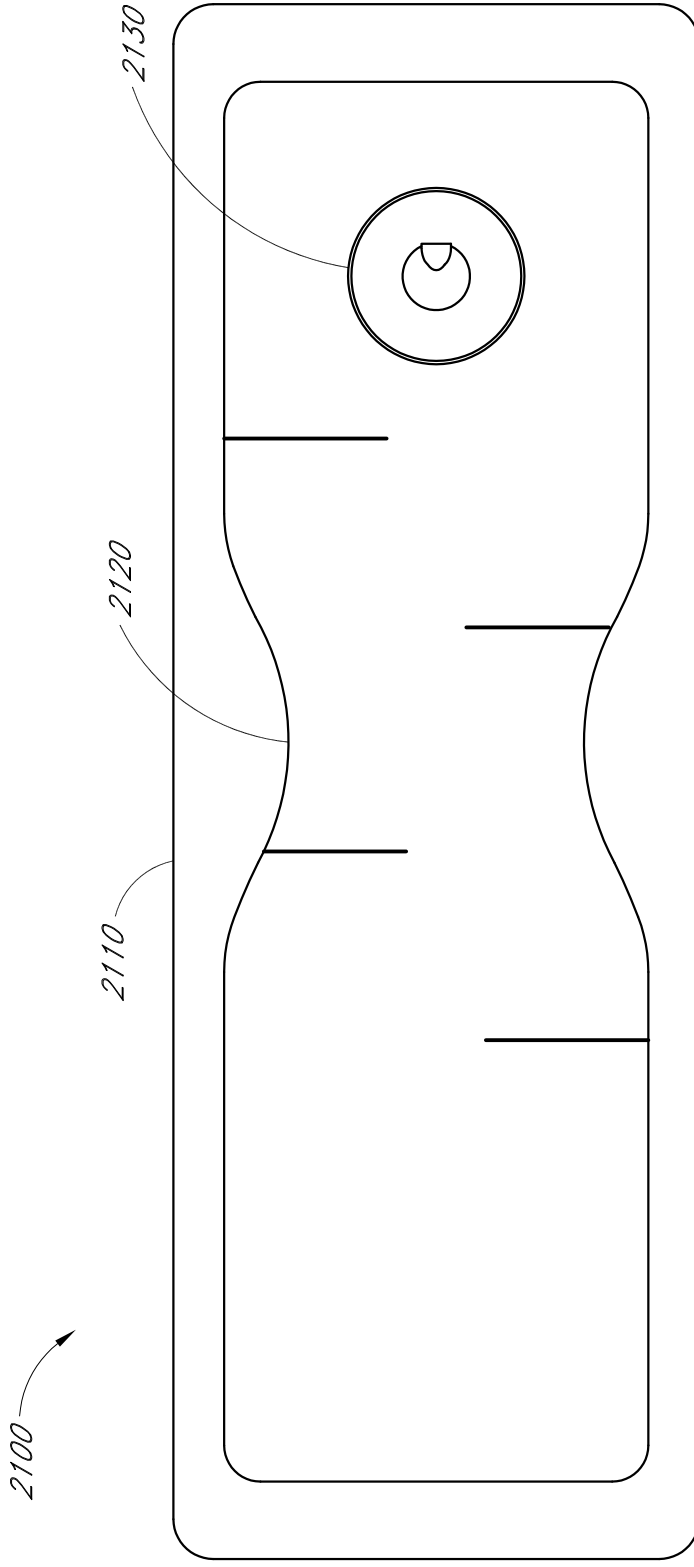

FIG. 15B

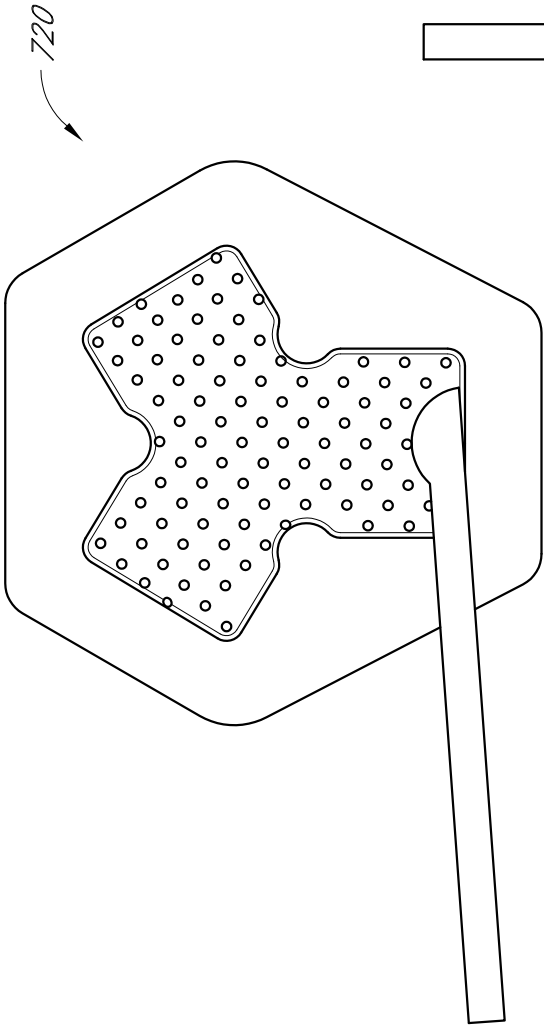

FIG. 17

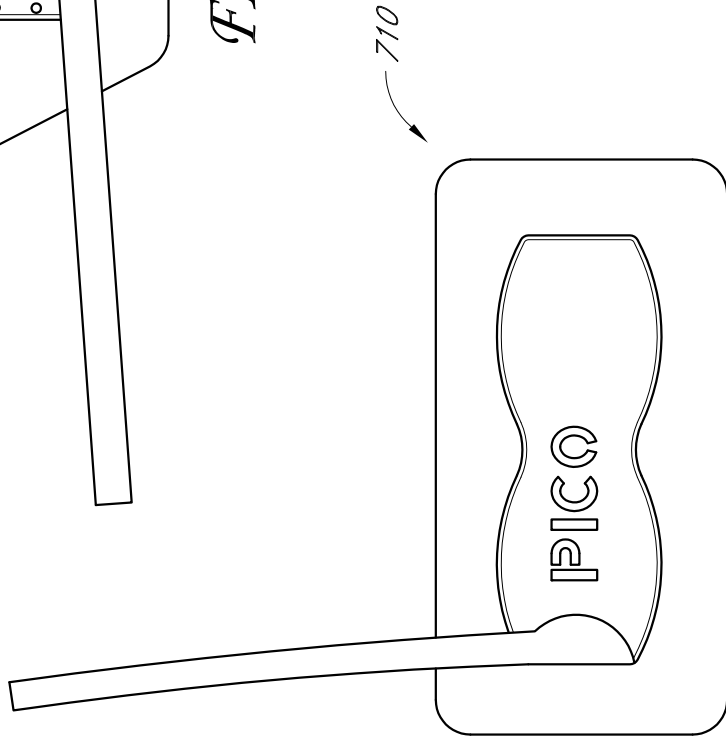

FIG. 16

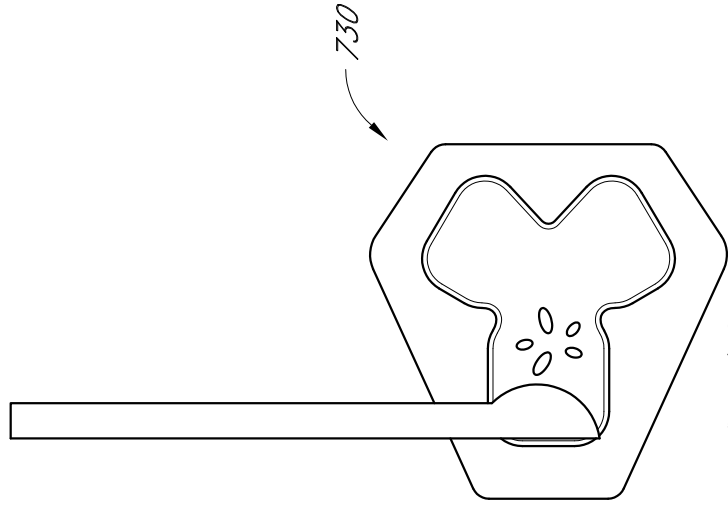

FIG. 18

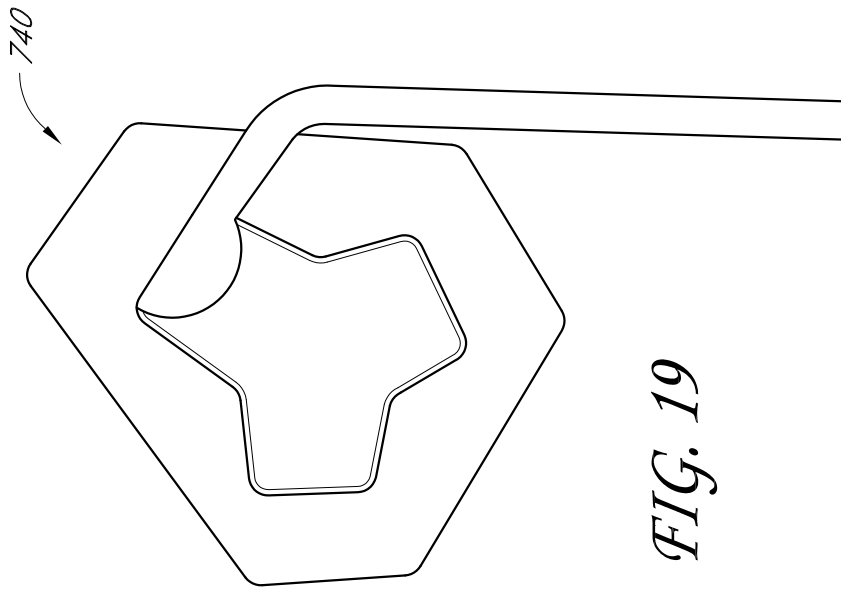

FIG. 19

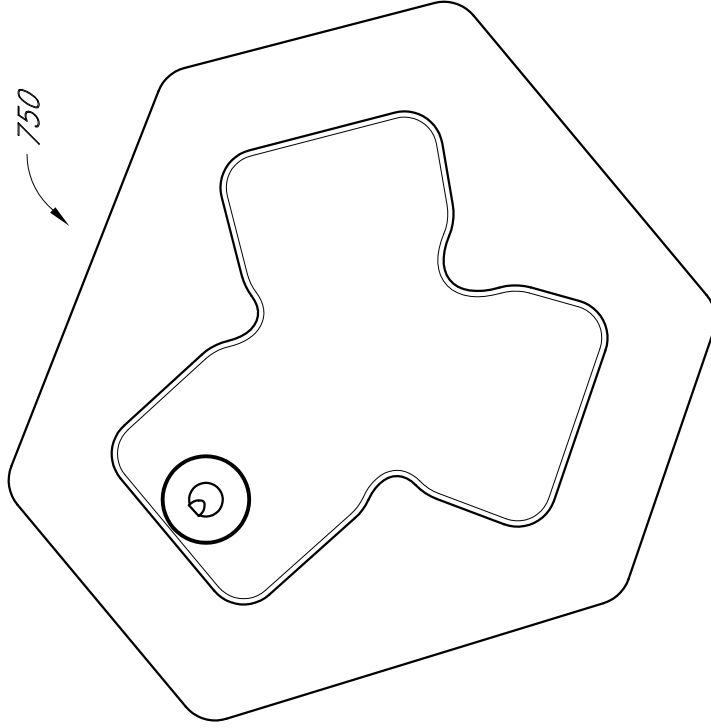

FIG. 20

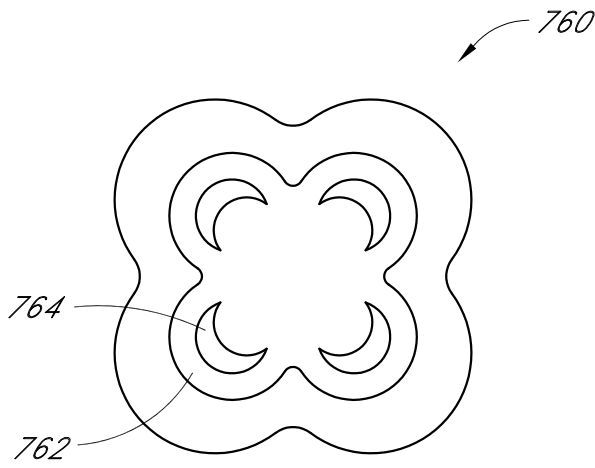

FIG. 21A

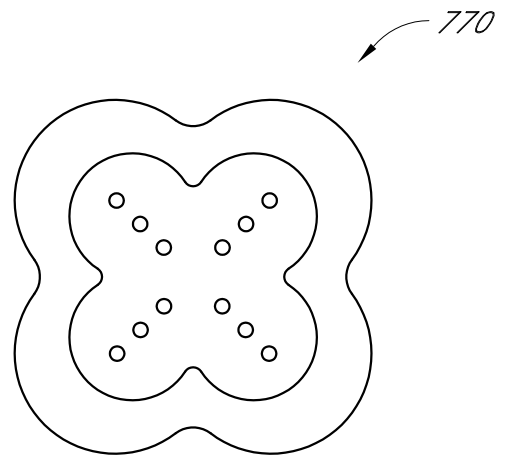

FIG. 21B

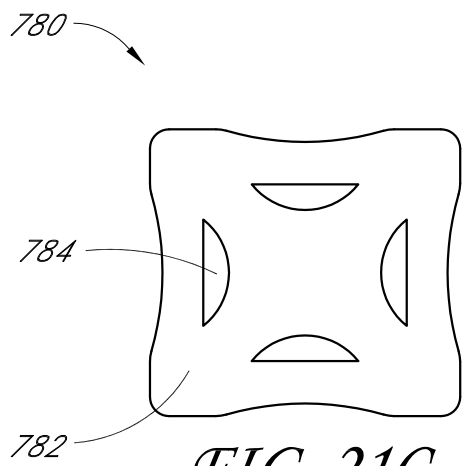

FIG. 21C

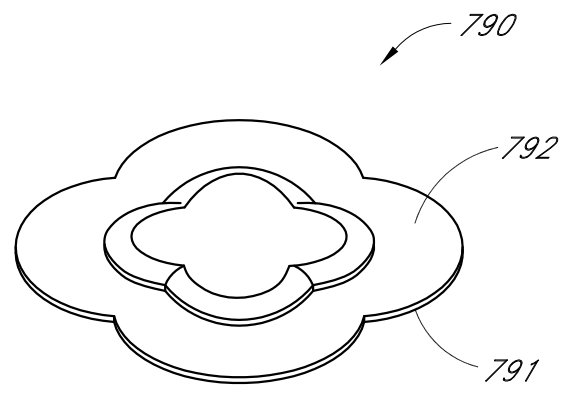
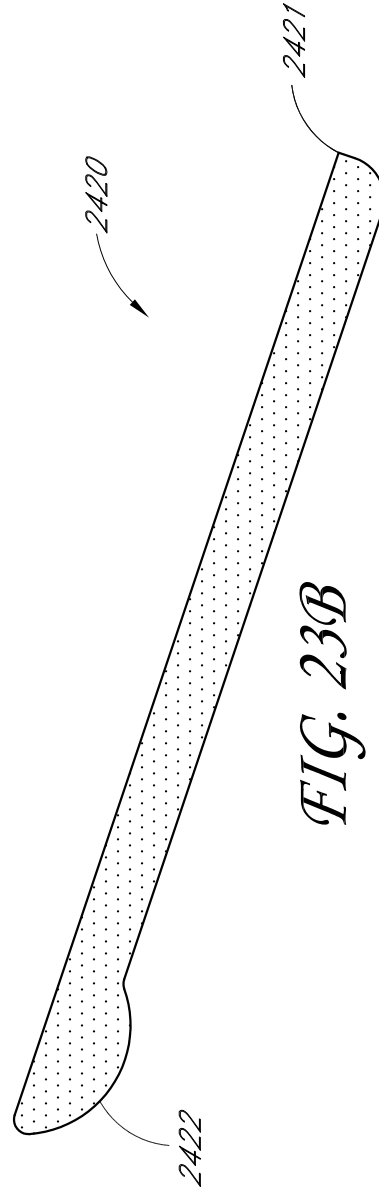
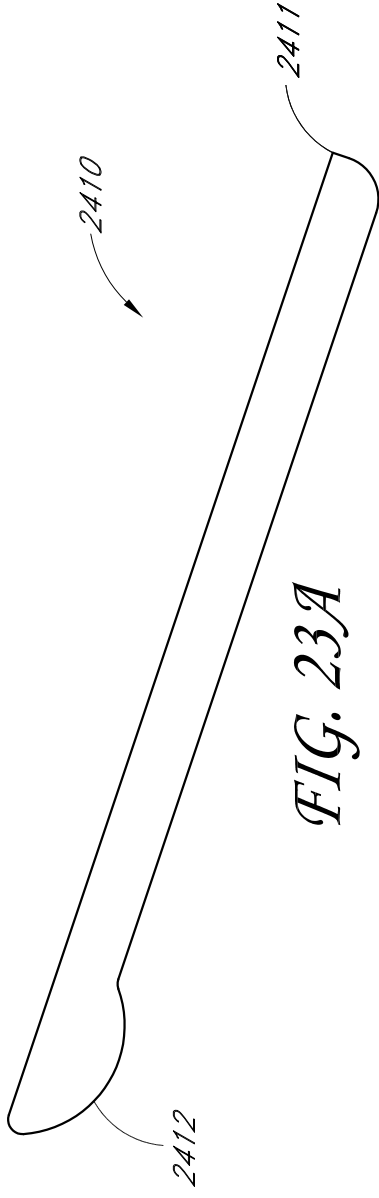

FIG. 22



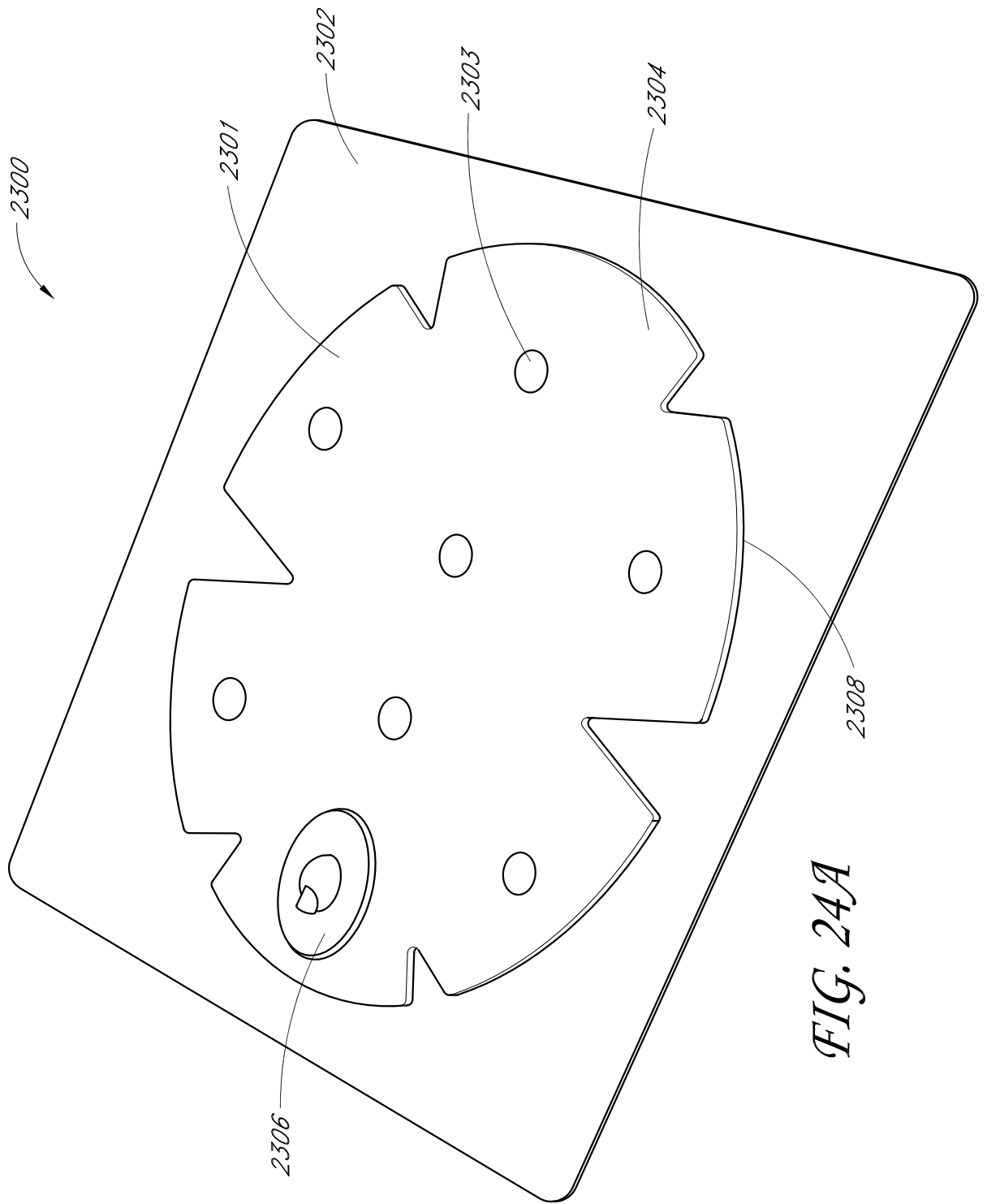

FIG. 24A

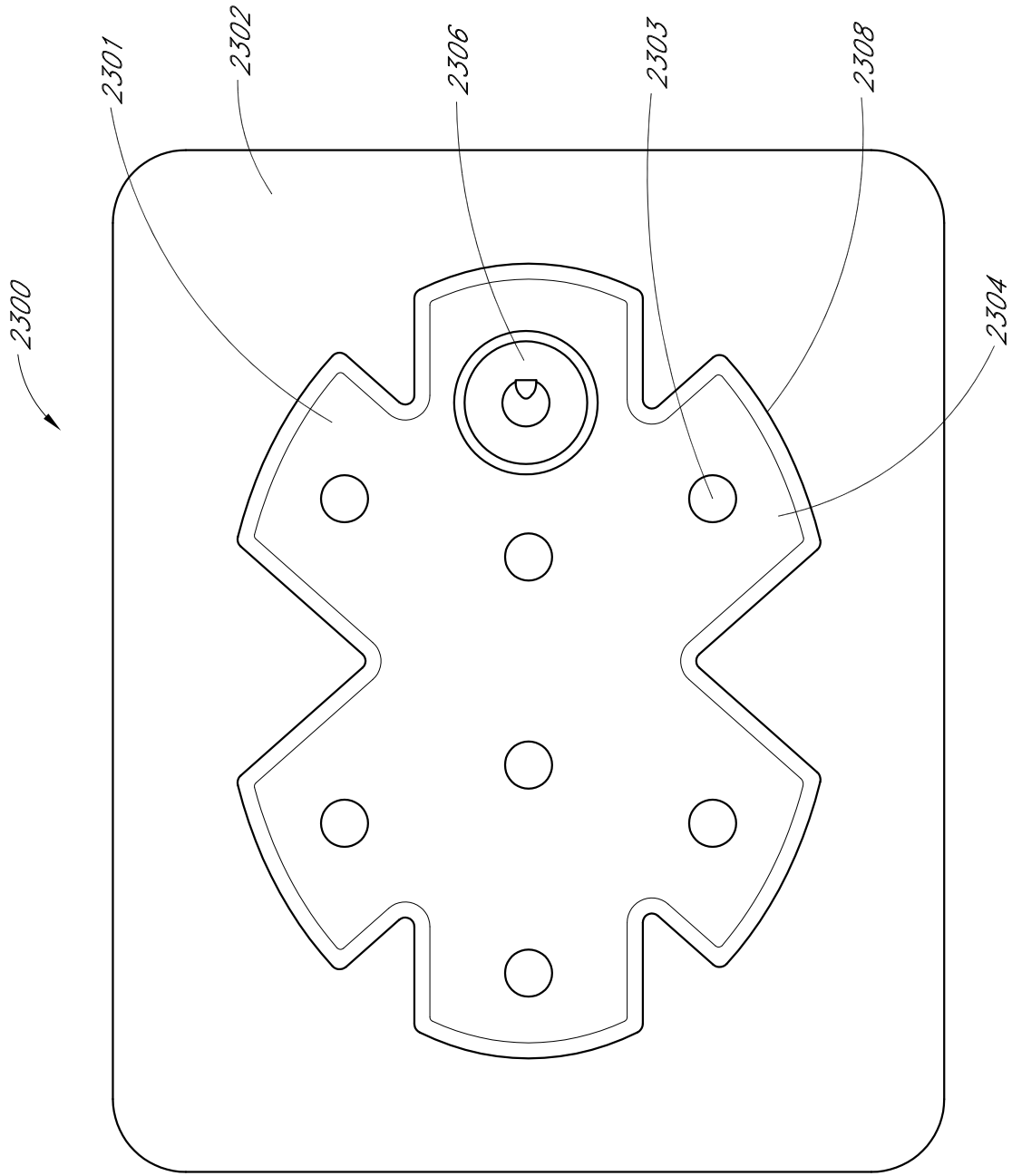

FIG. 24B

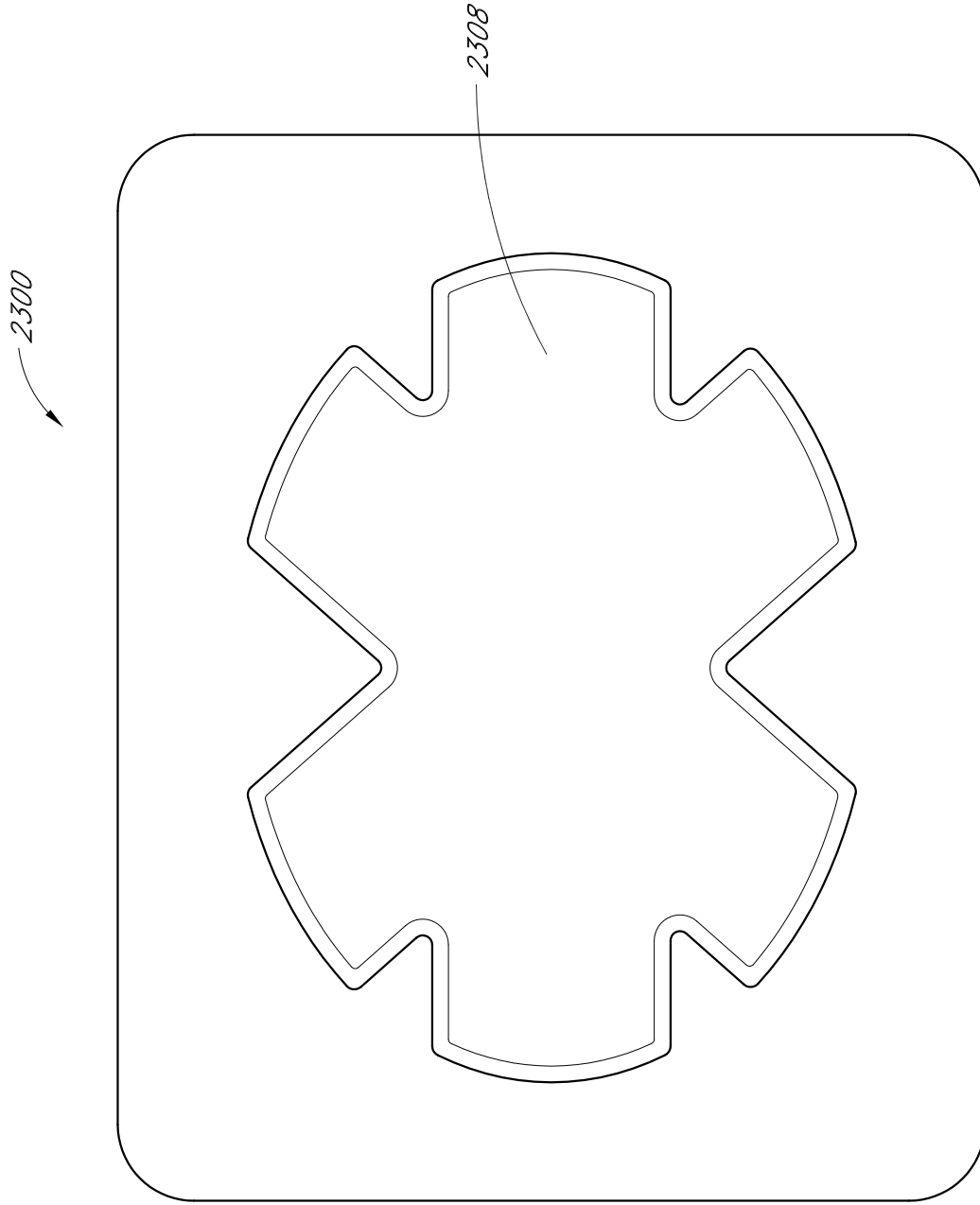

FIG. 24C

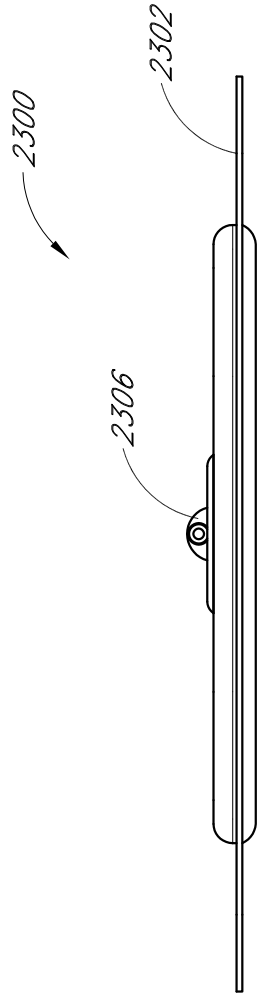

FIG. 24D

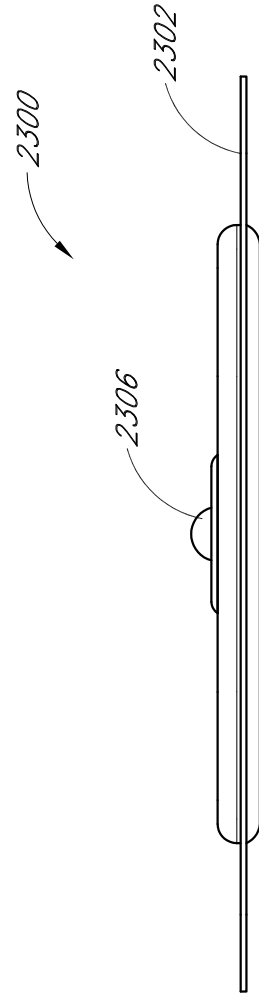

FIG. 24E



FIG. 24F

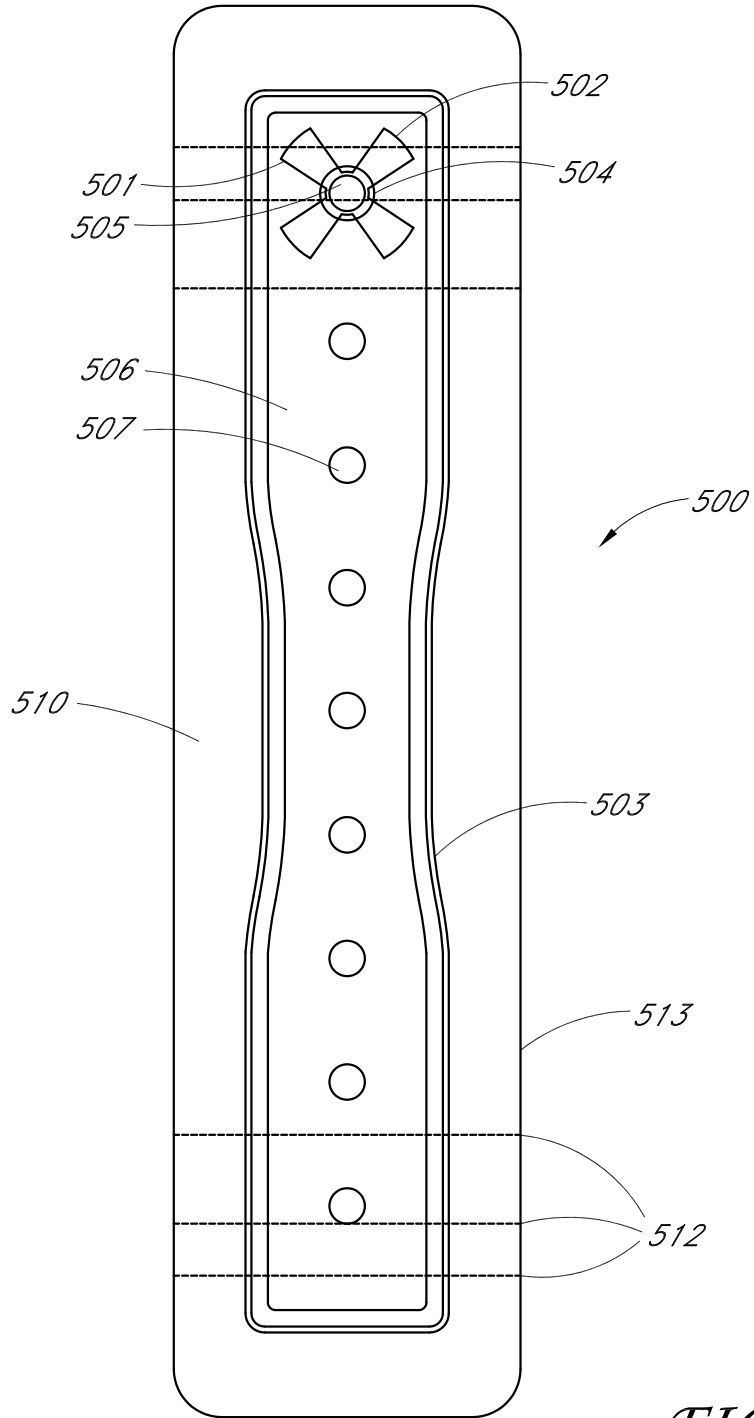

FIG. 25

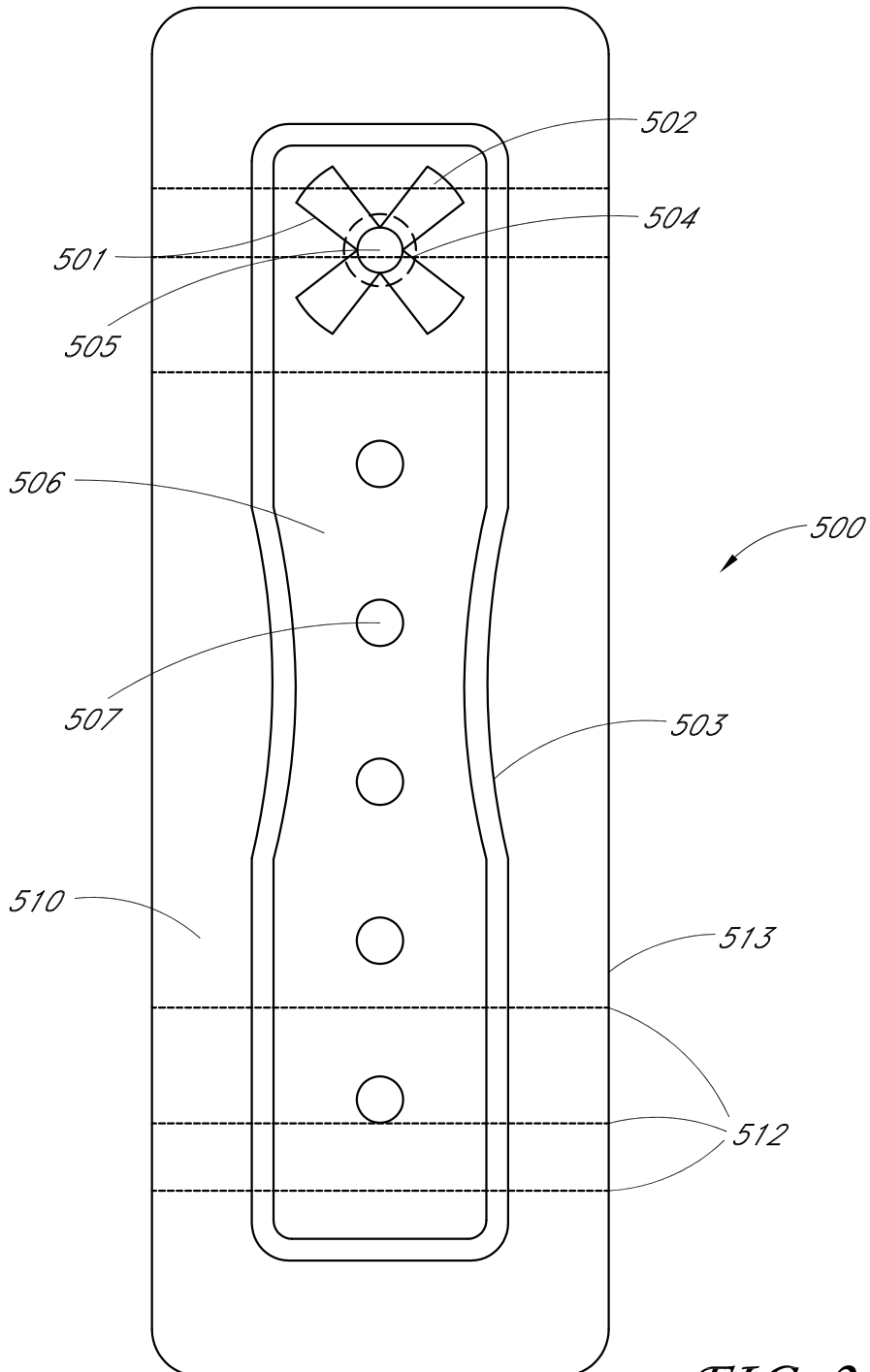

FIG. 26

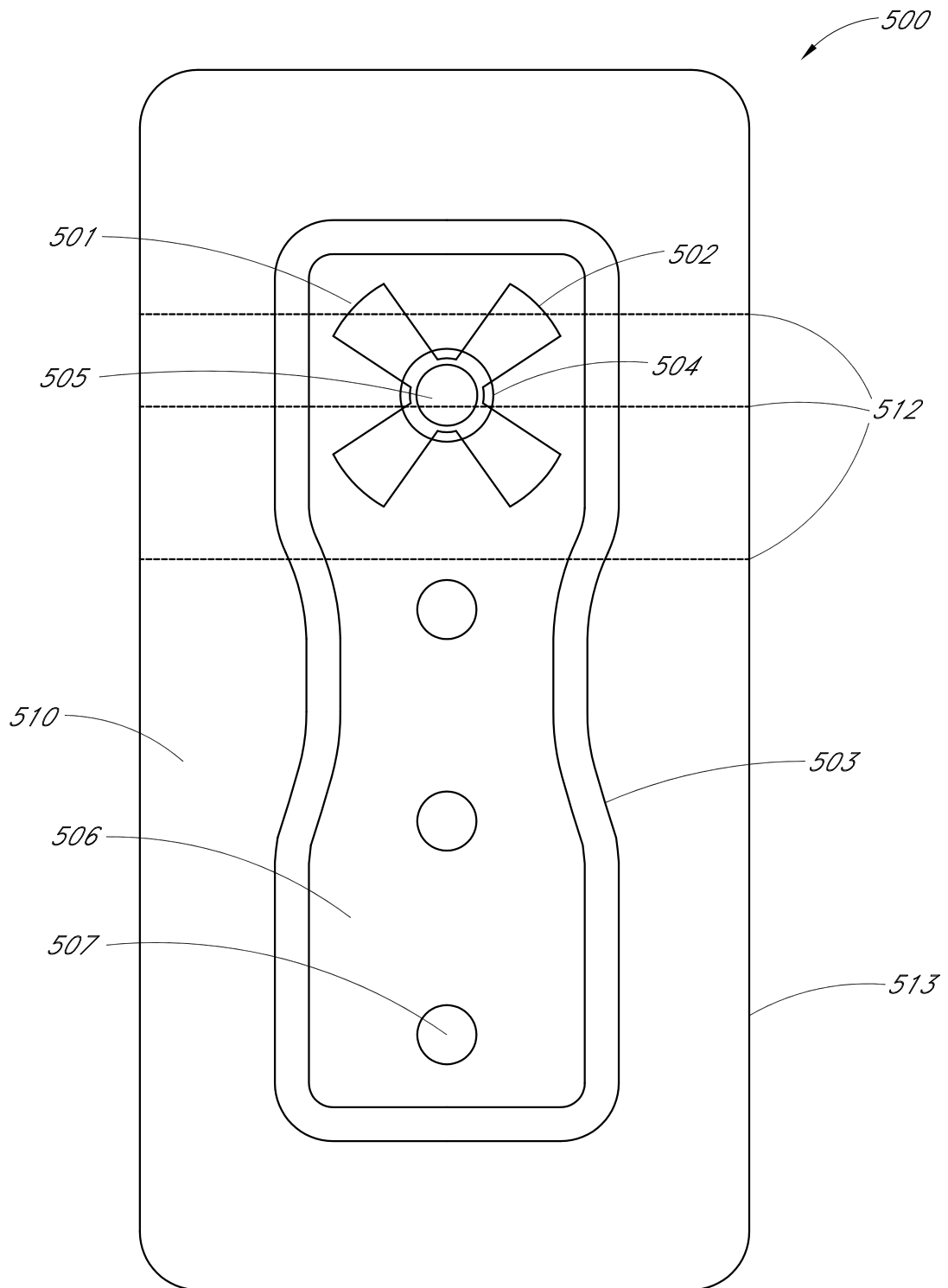

FIG. 27

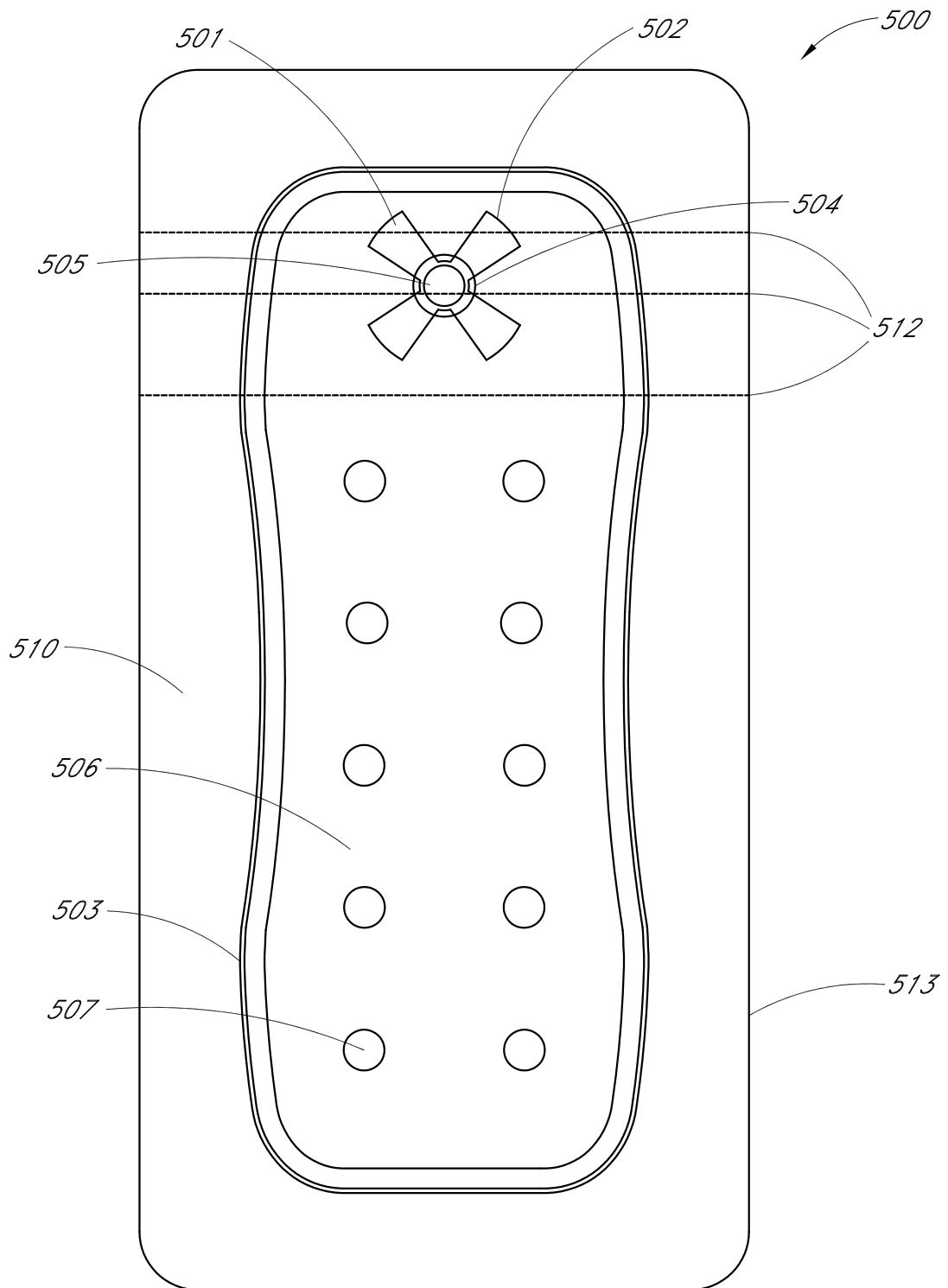

FIG. 28

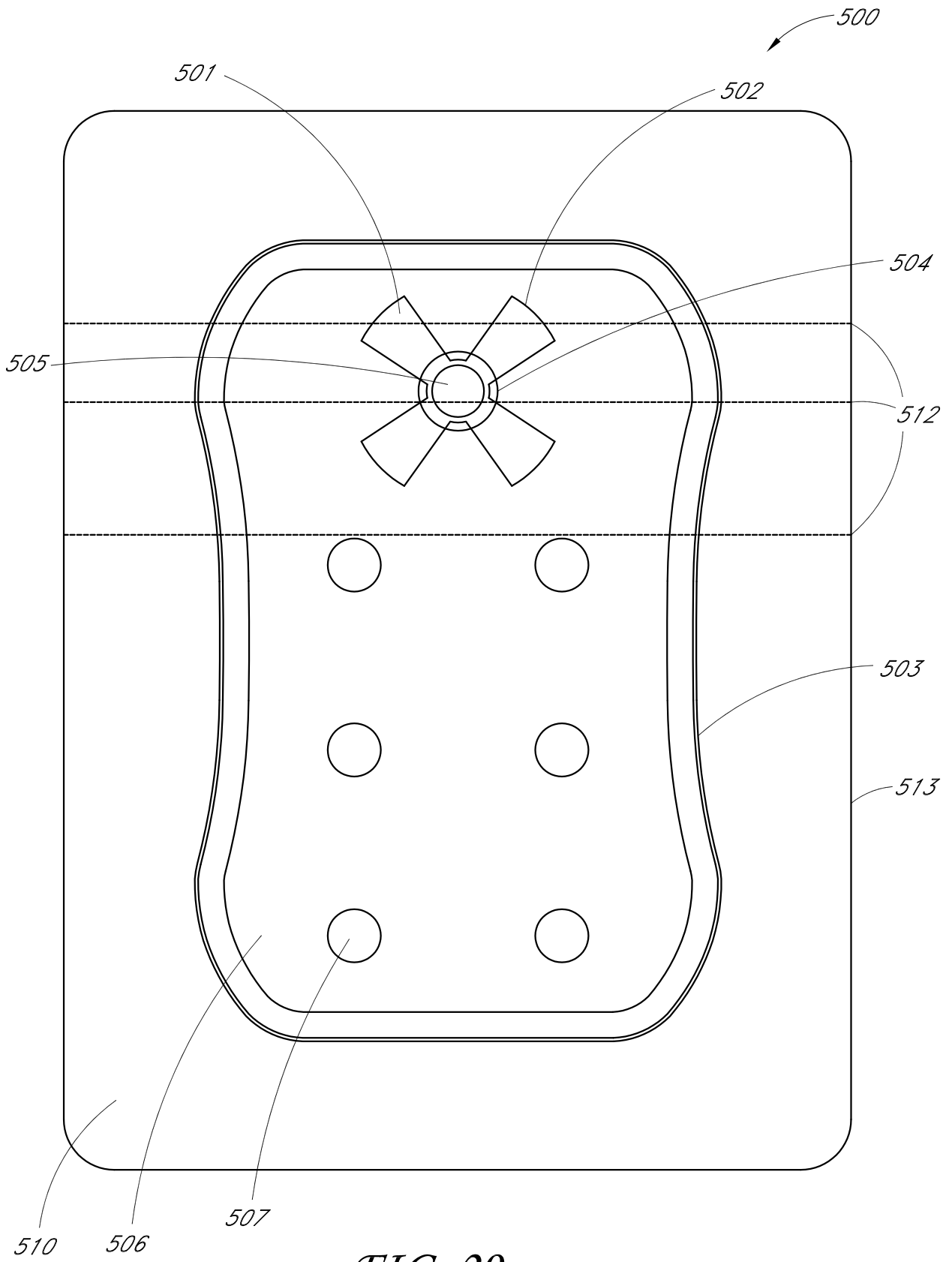

FIG. 29

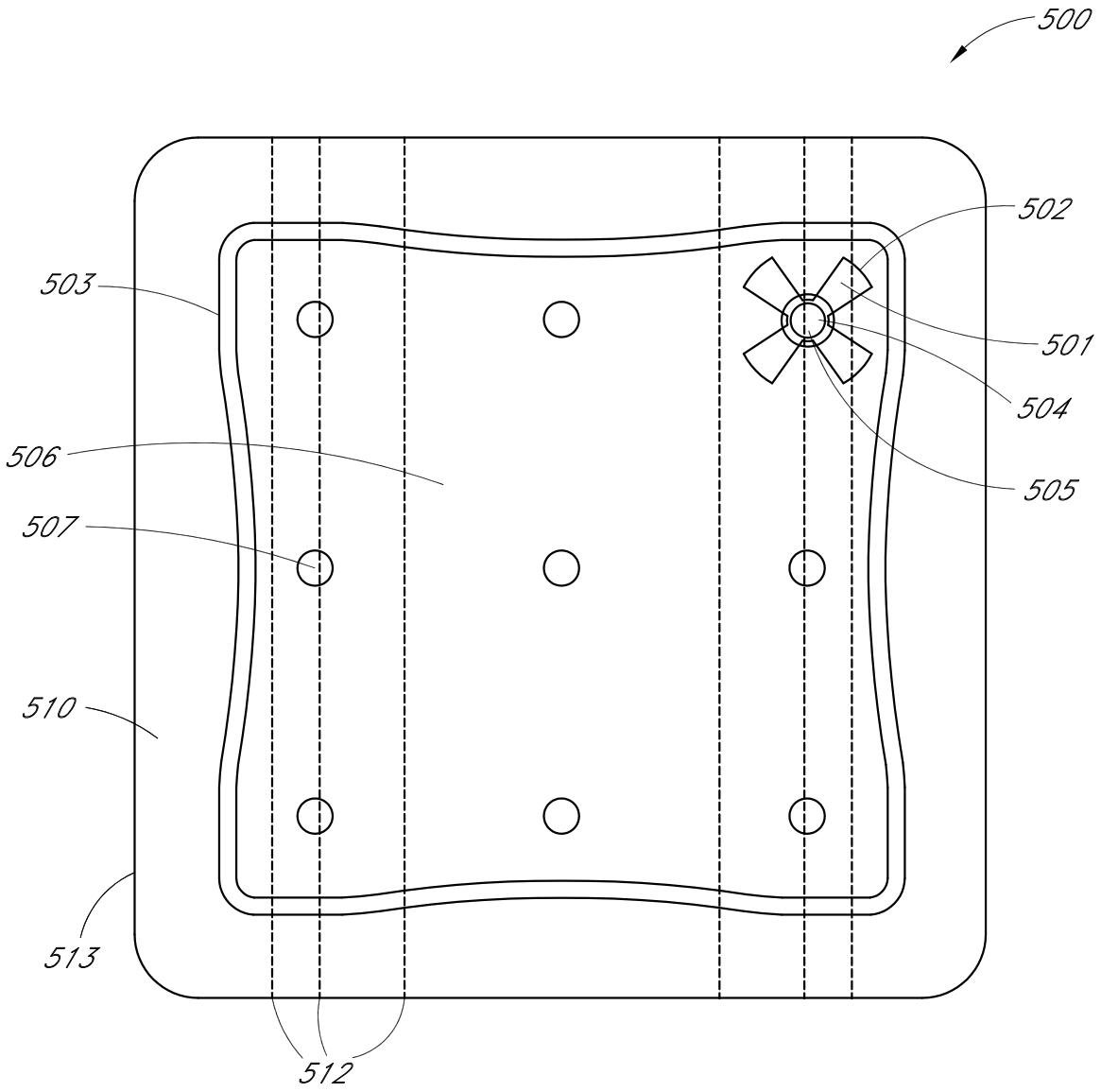

FIG. 30

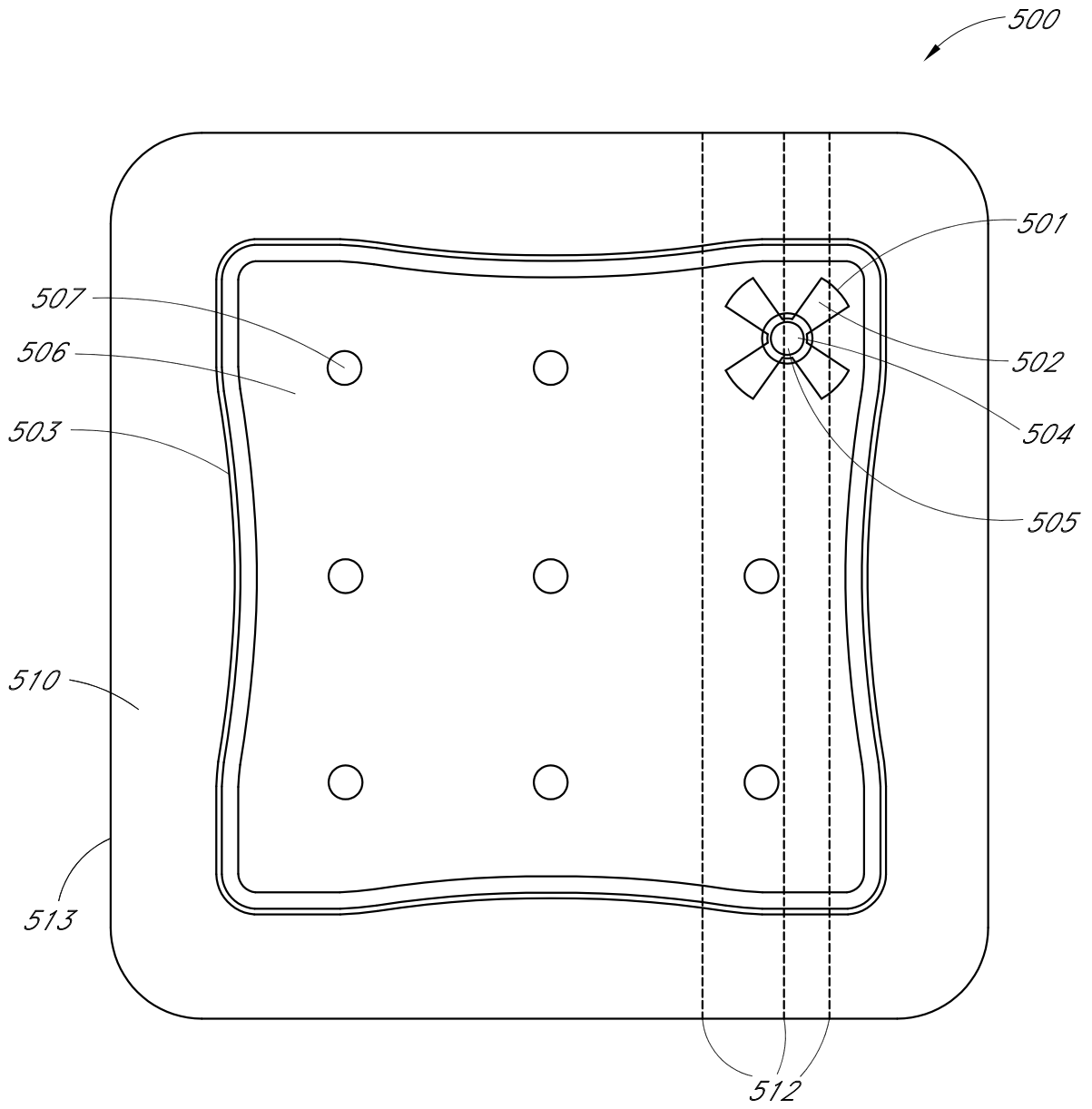

FIG. 31

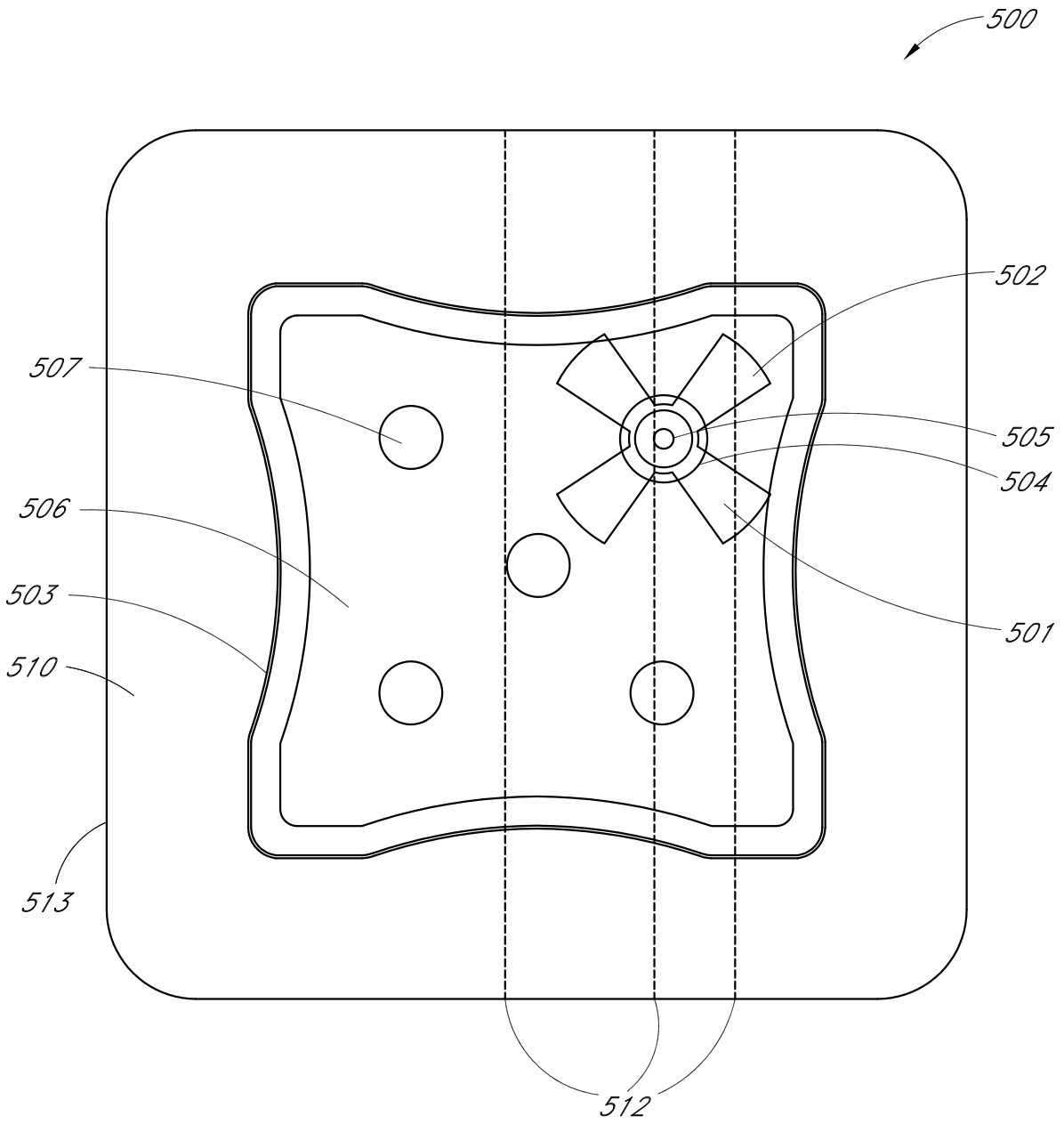

FIG. 32

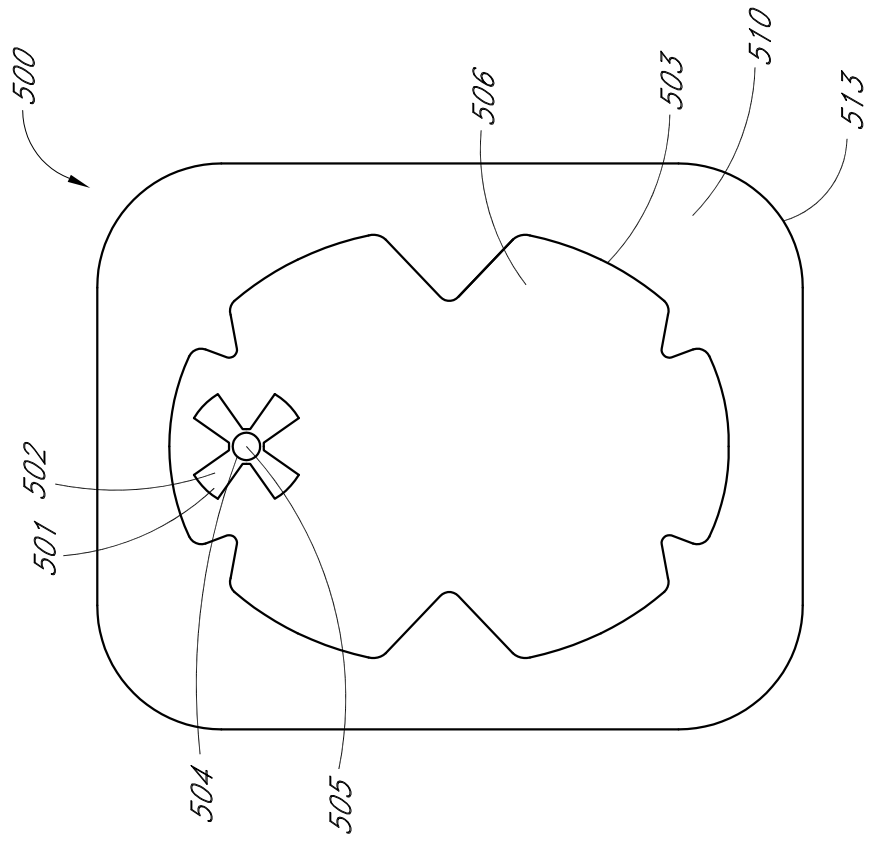

FIG. 33A

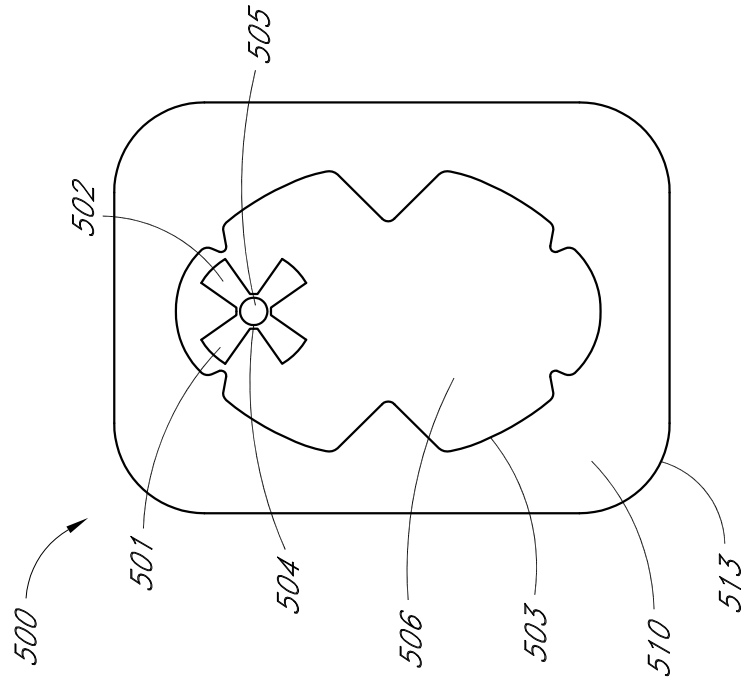

FIG. 33B

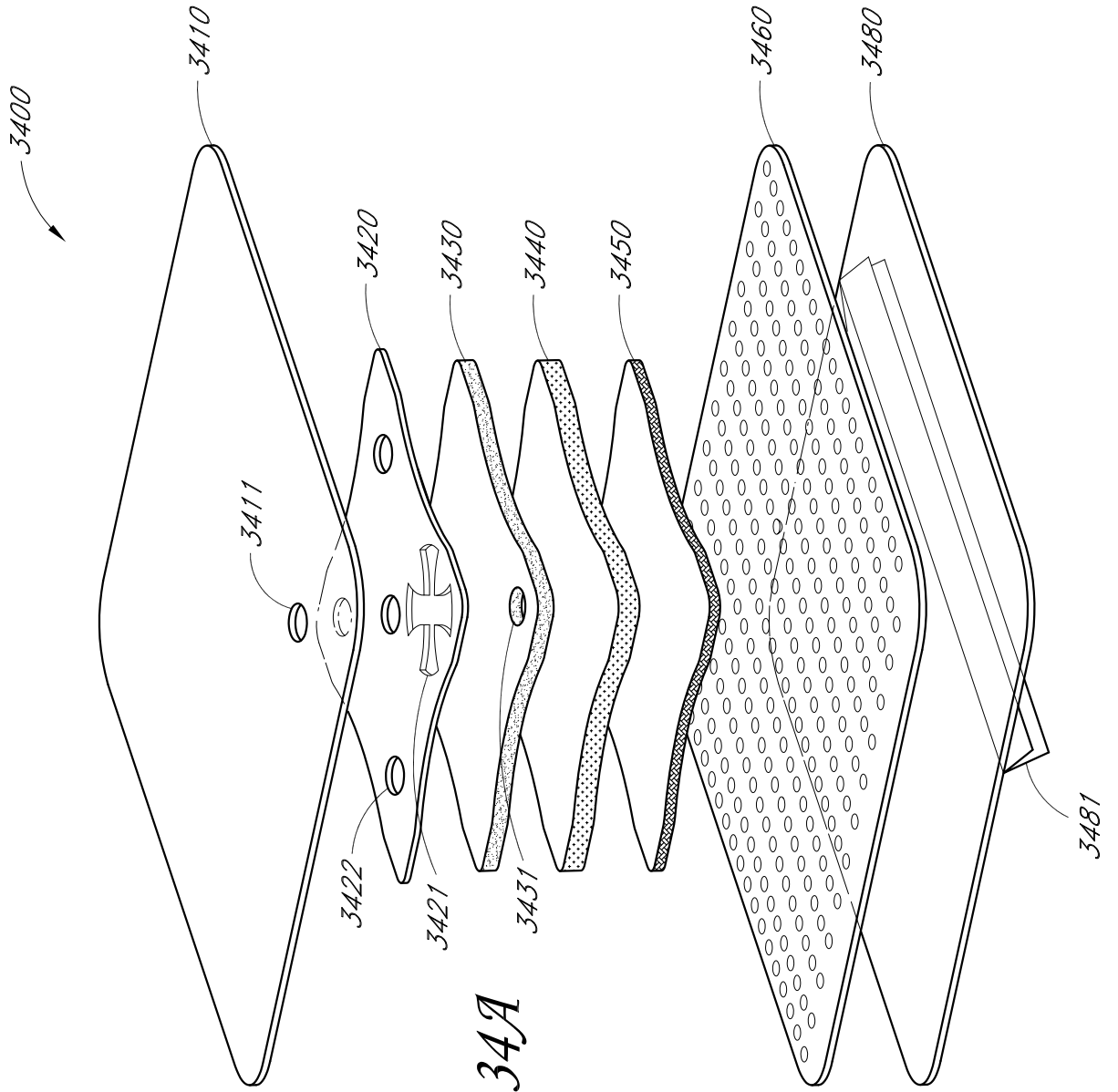

FIG. 34A

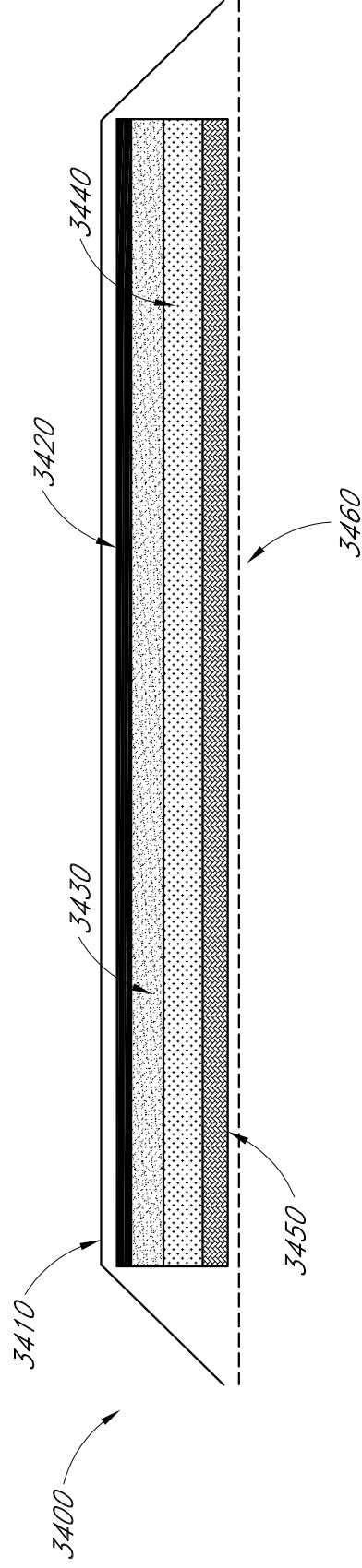

FIG. 34B

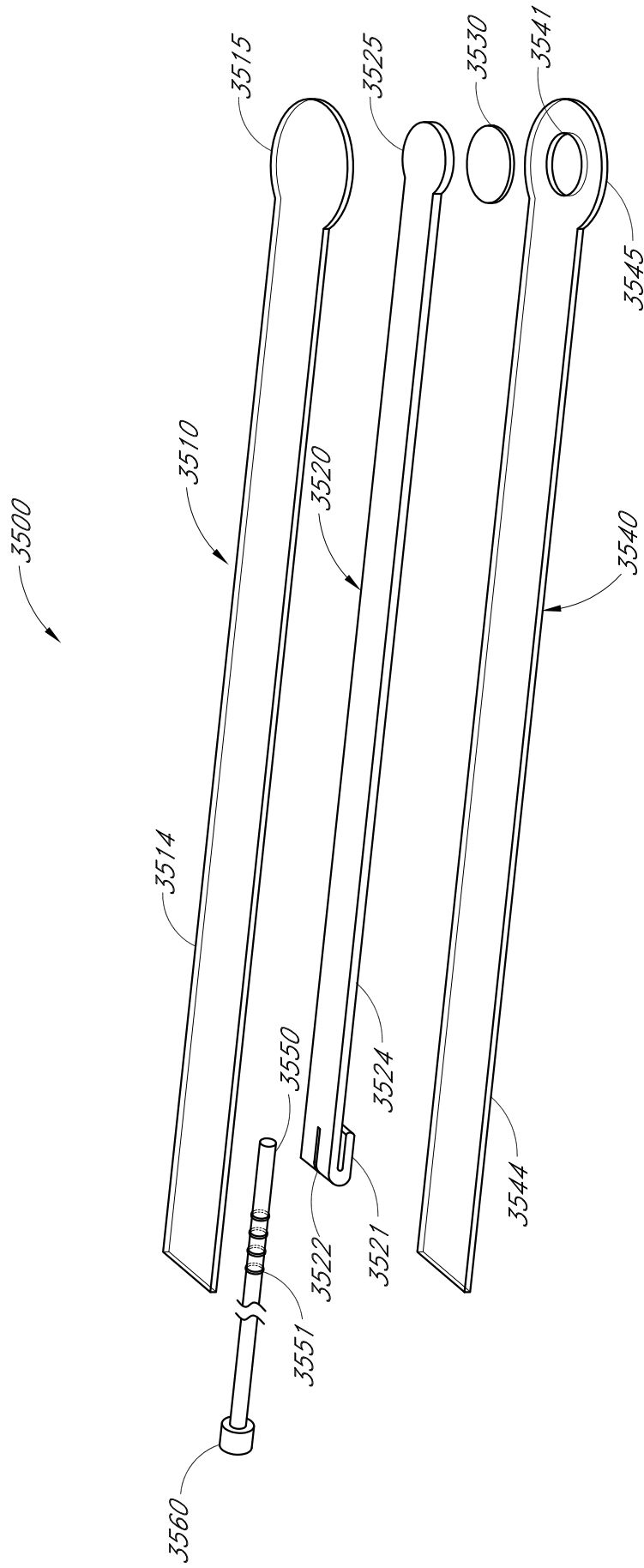

FIG. 35

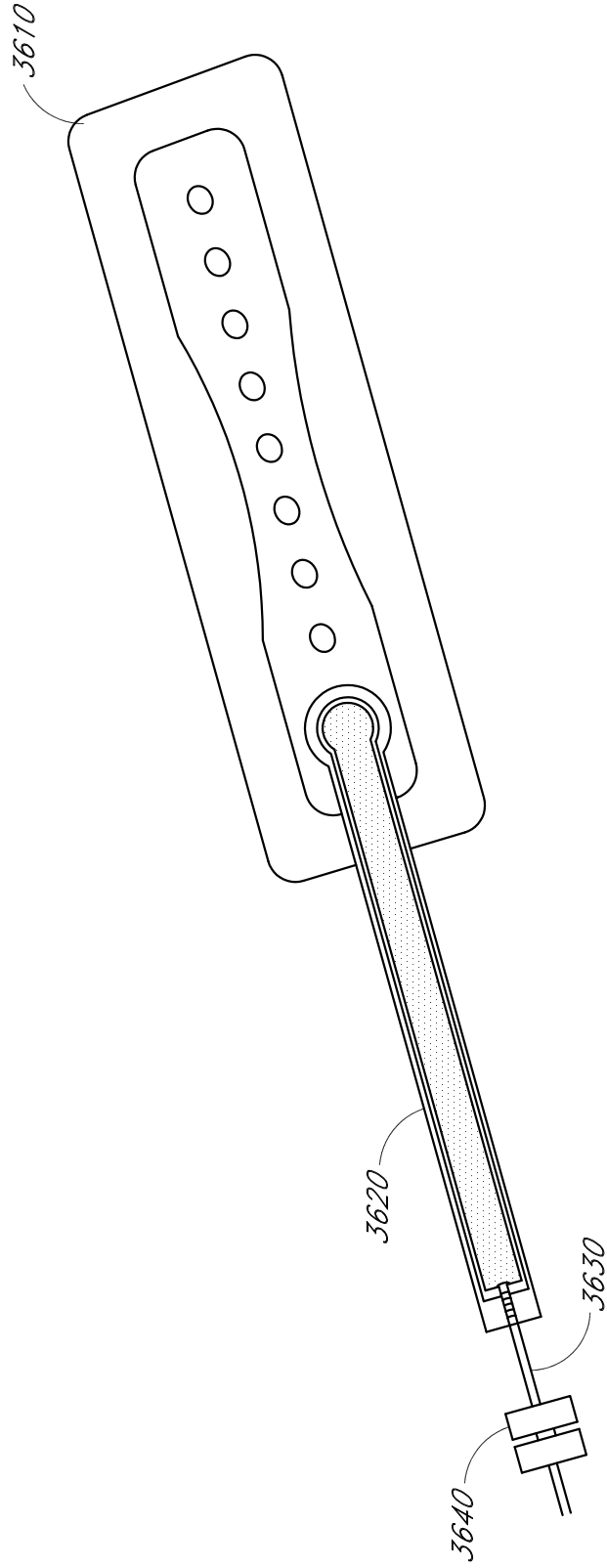

FIG. 36

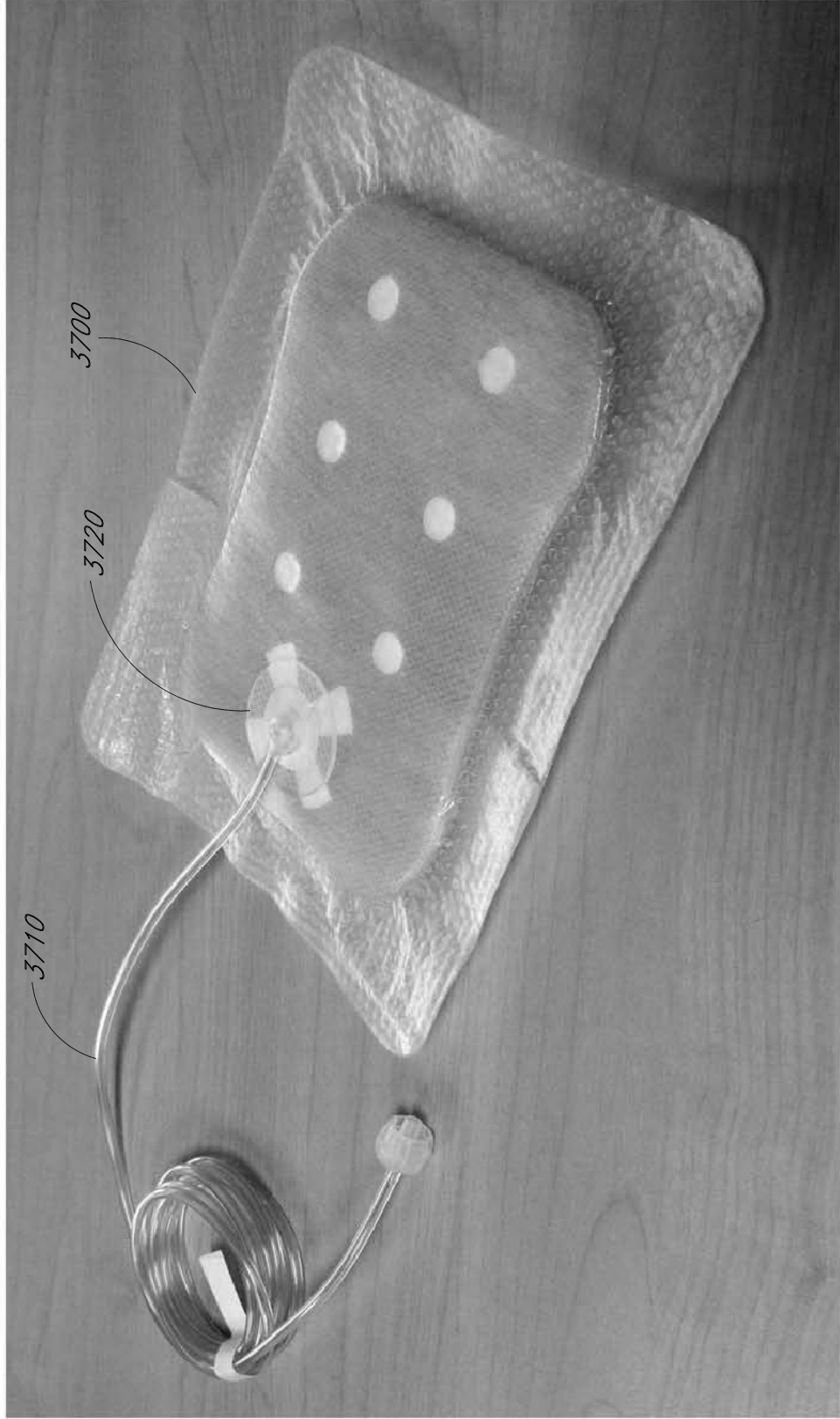

FIG. 37A

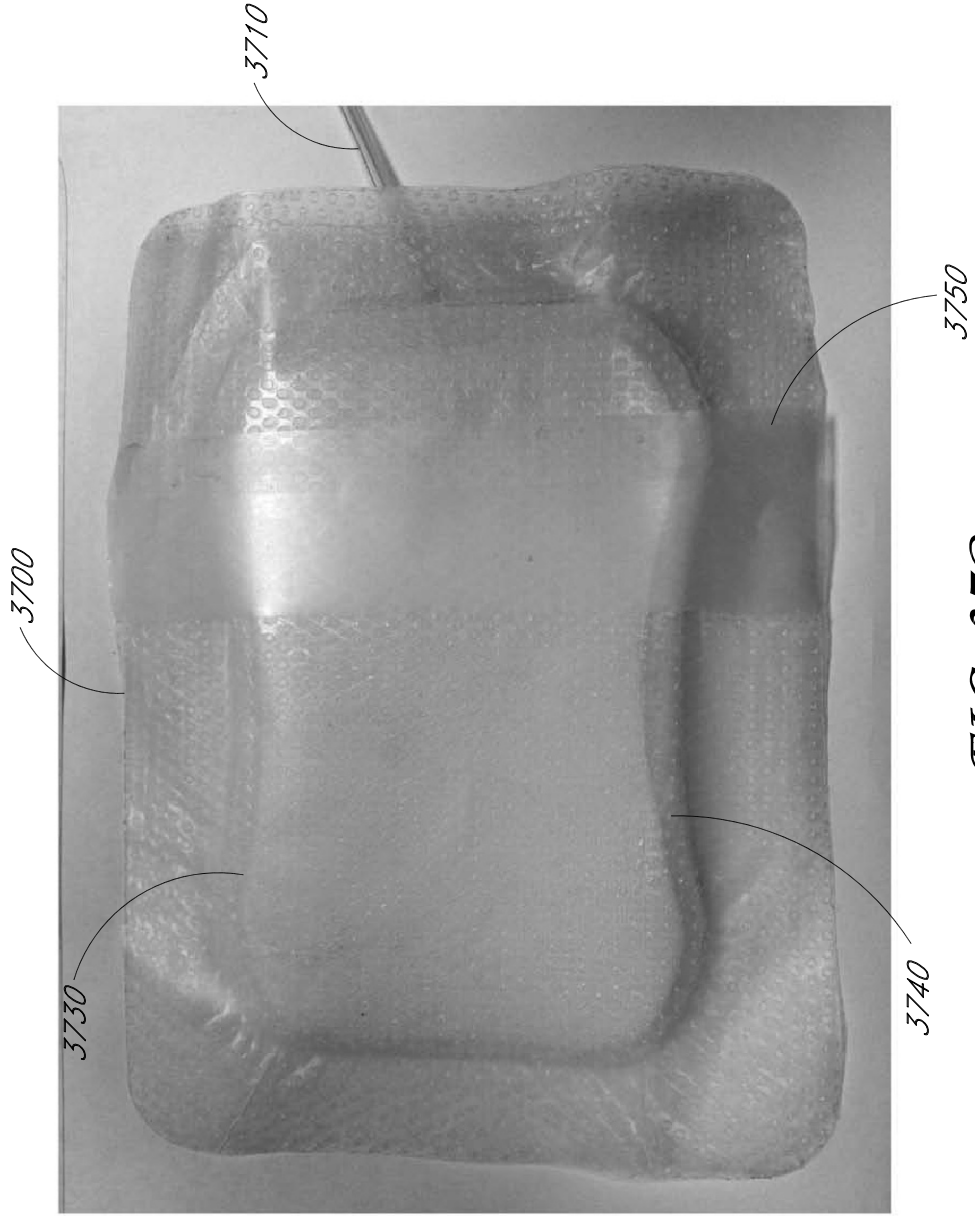

FIG. 37B

