

(12) UK Patent Application (19) GB (11) 2 302 952 (13) A

(43) Date of A Publication 05.02.1997

(21) Application No 9513811.1

(22) Date of Filing 06.07.1995

(71) Applicant(s)
C & C Technology Enterprises (BVI) Limited

(Incorporated in the British Virgin Islands)

**P O Box 116, The Creque Building, Road Town,
Tortola, British Virgin Islands**

(72) Inventor(s)
Ding Chen
Zhe Chen

(74) Agent and/or Address for Service
D Young & Co
21 New Fetter Lane, LONDON, EC4A 1DA,
United Kingdom

(51) INT CL⁶
G01R 21/133 11/24

(52) UK CL (Edition O)
G1U UR1124 UR21133

(56) Documents Cited
GB 2280960 A GB 2245372 A GB 1564255 A
GB 1543501 A GB 1535835 A GB 1527507 A
US 4803632 A

(58) Field of Search
UK CL (Edition N) **G1U UR1124 UR1160 UR21133**
UR2200
INT CL⁶ **G01R 11/24 11/60 21/133 22/00**
Online: WPI

(54) Electrical power consumption control and evaluation system

(57) An interactive power consumption control and evaluation system comprises a central control computer with management software and a group of communication controllers consisting of transmitters, receivers, and modems and insulators. The communication controller connects to a data exchanger in the user's interactive power meter which comprises a meter case, a data display, and a PCB board. A buzzer, a select button, and an alarm reset button are designed on the face of the meter case. On the PCB board, there is a single chip microcomputer, program storage, data memory, a transmitter and receiver module, an A/D and D/A conversion module, a theft control, a power line balance detection module, as well as a power supply module. The invention addresses many problems in current power supply management and is effective total automatic power supply management system with a computer network.

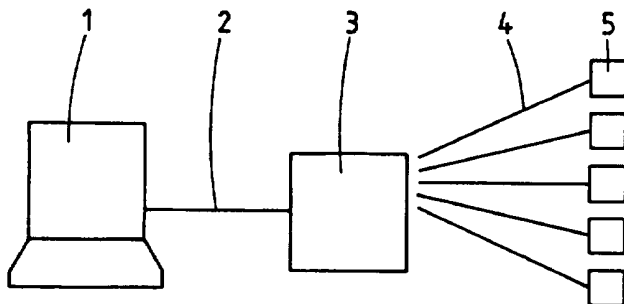

FIG.1

GB 2 302 952 A

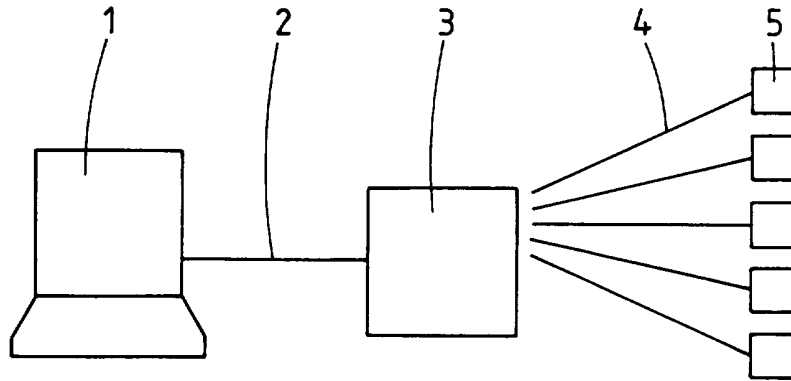

FIG.1

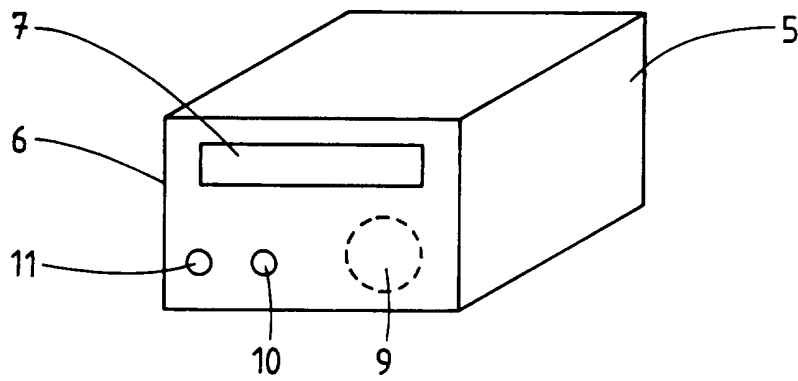

FIG.2

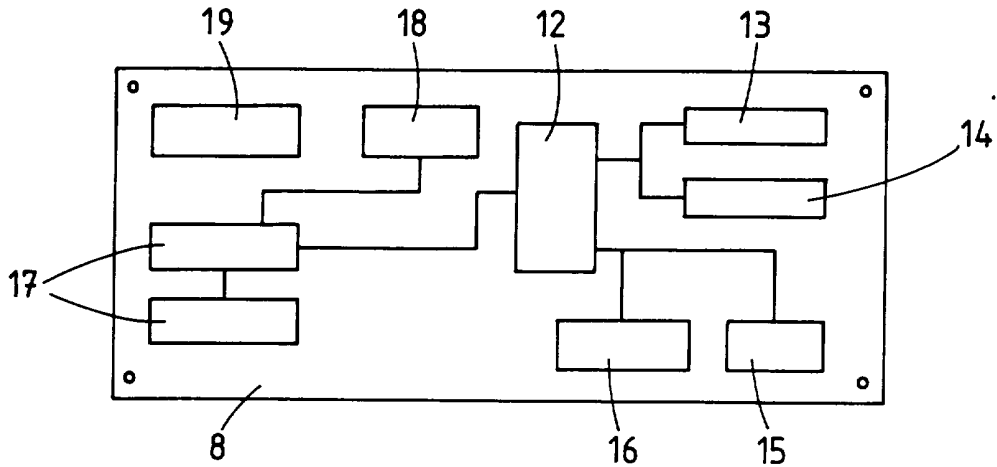

FIG. 3

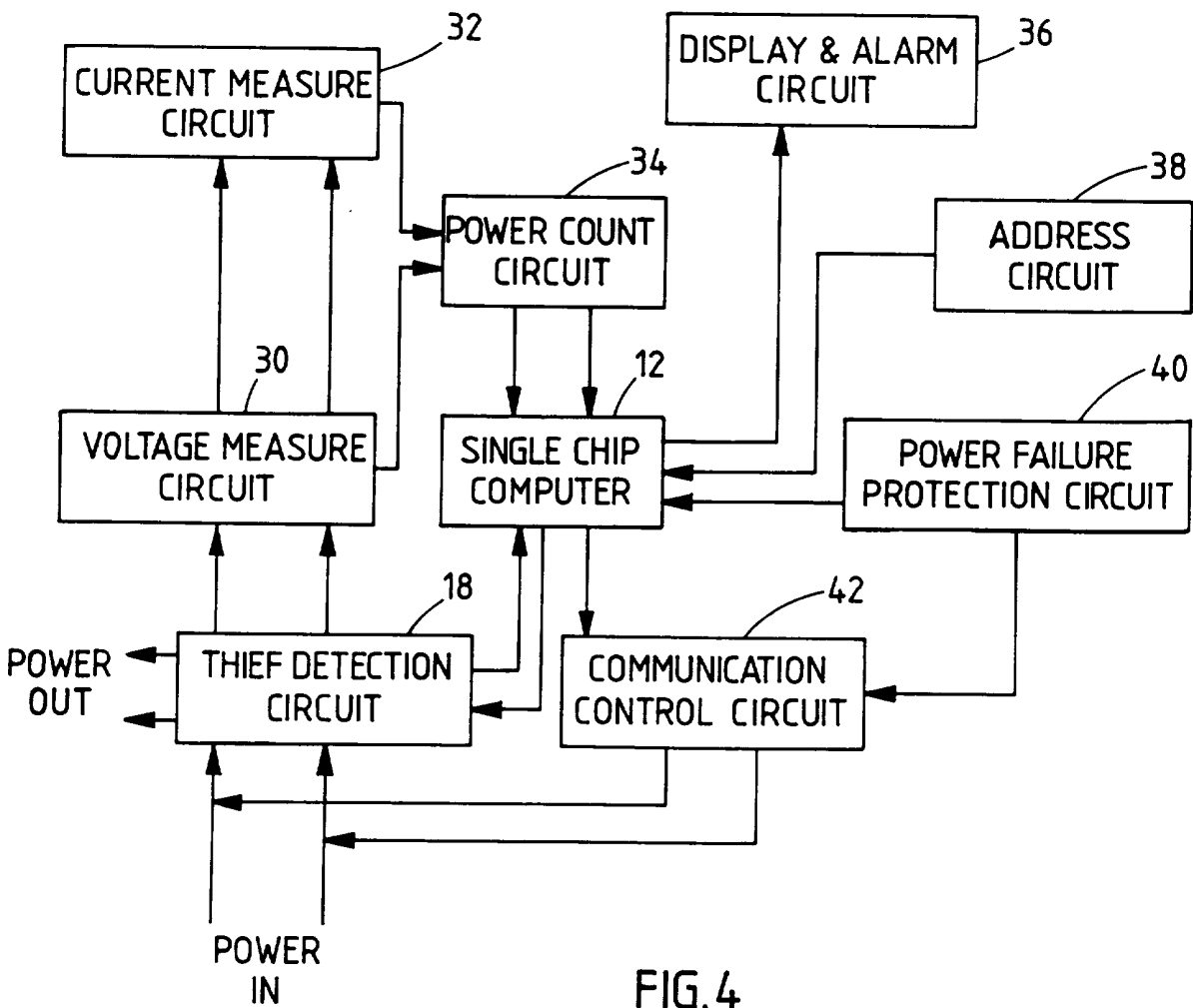

FIG. 4

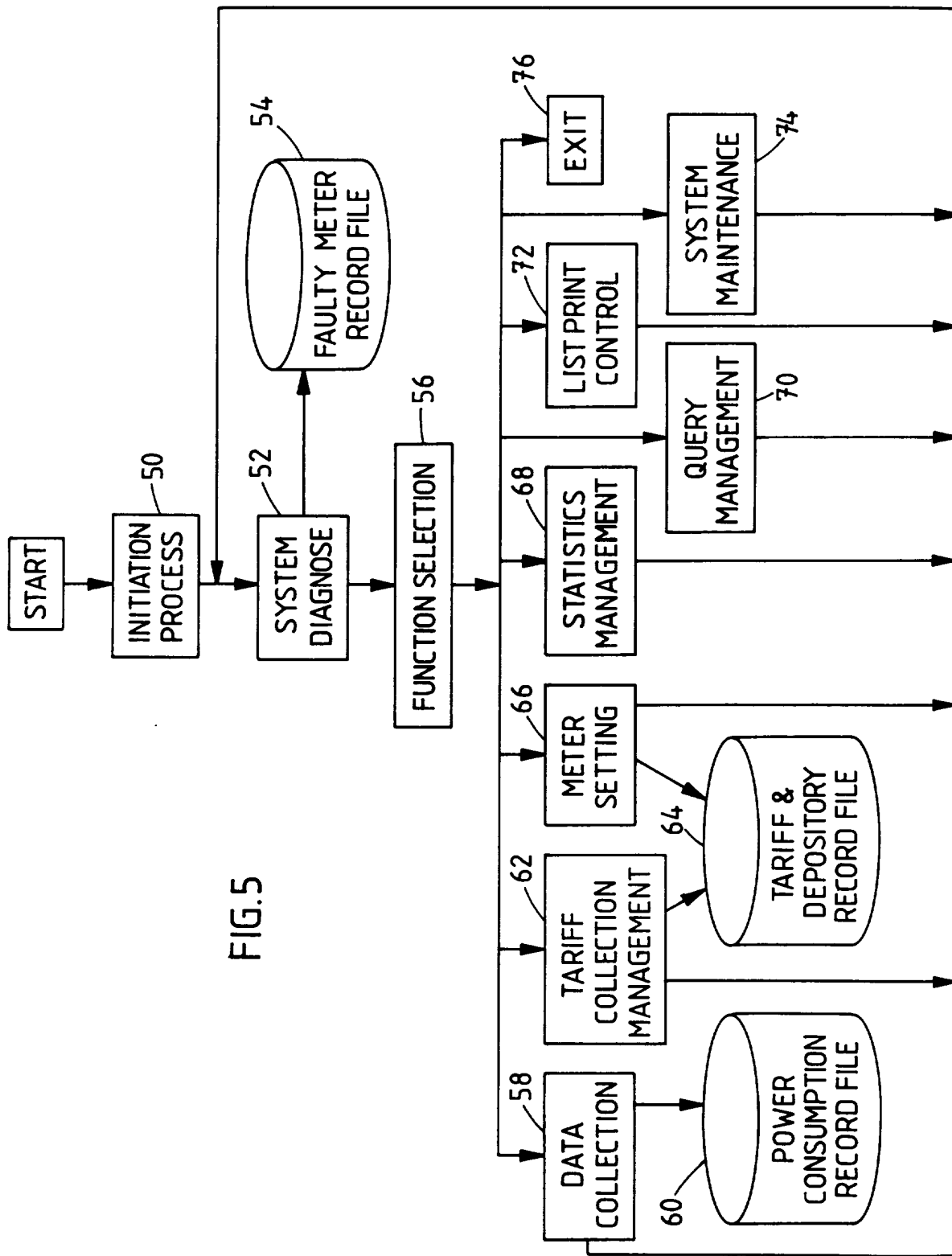

FIG.5

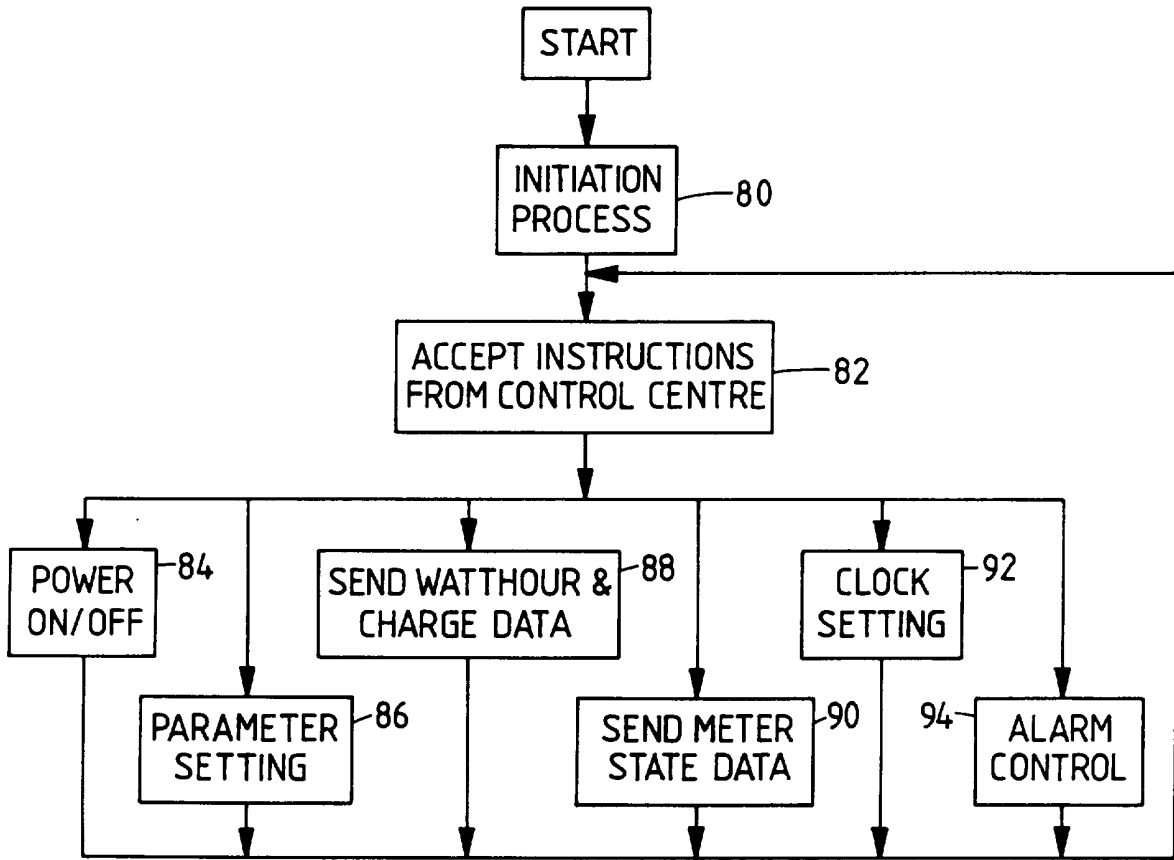

FIG.6

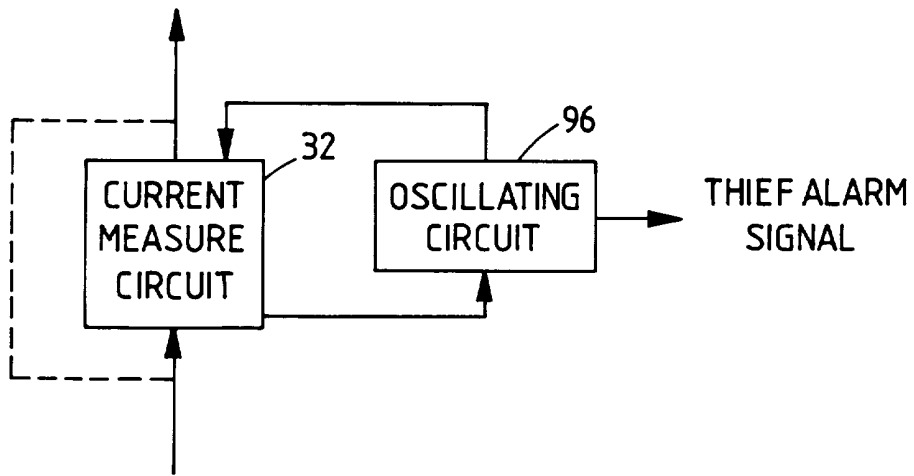

FIG.7

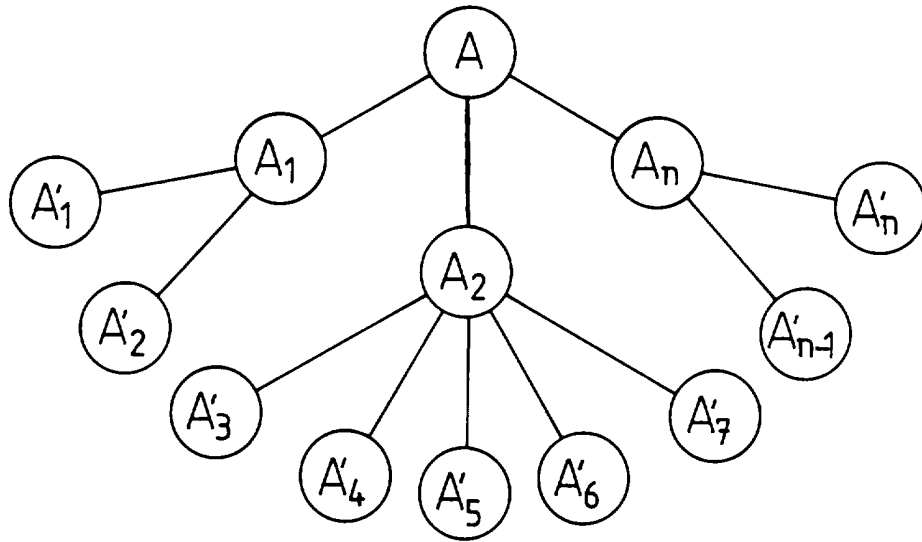

FIG.8

ELECTRICAL POWER CONSUMPTION
CONTROL AND EVALUATION SYSTEM

5 The present invention relates to electrical power consumption control and evaluation systems.

There are many disadvantages in previously proposed systems for measuring and monitoring the electrical power supply consumption. For example, currently used power consumption meters are only price-billing machines, so it is hard to charge the user on power consumption at the time of both critical-load and non critical-load. Although the load of network power supply can be adjusted by shutdown on different load hours in some regions, the effects are not satisfactory, and this can also mean trouble for the customers. The process of tariff billing and collection is still a difficult burden to the power supply company.

10 Also, another problem involves the theft of power from power lines. Unauthorized access to power lines cannot be effectively controlled unless some means of manual inspection is employed. Manual inspection is both expensive and inefficient.

15 This invention provides an interactive power consumption control and evaluation system comprising a central controller, a power consumption data transfer mechanism and a series interactive power consumption meters, wherein

20 said central controller has of a set of computers with management software, a communication controller connected with cables,

said power consumption data transfer mechanism has said communication controller and data transfer media,

25 said communication controller has a transmitter and receiver which includes modems and insulators,

said communication controller is connected with a data communication part inside said power consumption meters through communication medium,

the system network structure is a star-shape,

30 said interactive power consumption meter has a case, a data display part, a meter PCB board (printed circuit board), a single chip microcomputer, program storage, data memory, said transmitter and receiver, an A/D and D/A module, a theft

control and power line balance detection module, and a power supply module.

This invention also provides a power consumption detection system comprising:

5 a plurality of consumer power consumption meters, each meter having means for measuring electrical power consumption, means for communicating with a control apparatus, and means for controlling the supply of power to a consumer in response to meter control commands received from the control apparatus; and

10 a control apparatus having means for communicating with each power consumption meter and means for issuing meter control commands to at least one of the meters to control the supply of power to a consumer via that meter.

Further respective aspects of the invention are defined in the appended claims.

Embodiments of the present invention provide an intelligent power consumption monitoring and control and evaluation system which allows a computer network to automatically manage the power supply system.

15 One embodiment of the present invention is composed of a central controller, a power consumption data transfer mechanism, and a series of interactive power consumption meters. Each meter can control the power supply to a consumer via that meter, e.g by shutting off the power in case a power theft is detected, in case the user has not paid his bill, or in case of an excess network load being detected.

20 In this embodiment, network management software runs a computer at a central controller. A communication controller, part of a larger communication mechanism, is connected to the central controller via a cable. The communication mechanism consists of the communication controller and communication media. The communication controller consists of a highly sensitive receiver and high power transmitter with modems and insulators to convert analog and digital signals and to separate AC signals. The communication controller is connected with the data communication parts of interactive meters through a data medium.

25 There are various connections which are carried throughout power lines, special communication lines, and/or radio waves. Embodiments of the present invention have a network structure similar to the shape of a star. The first type of connection is suitable for civil application and general power supply. The other two types of connections are suitable for the situation in which high quality signal demand is

30

required, or power line data transfer is limited.

5 The interactive power meter PCB board has a buzzer connected to a display select button and an alarm reset button on the face of the meter case. On the PCB board, there is a single chip microcomputer, a program storage, a data memory, a transmitter, a receiver module, an A/D and D/A module, a theft control and power line balance detect module, and a power supply module. To allow the meter to possess electronic and automatic functionally, various technology is employed, such as a current detecting circuit, a voltage measuring circuit, a power counting circuit, a theft and unbalance alarming circuit, a communication control circuit, a power supply failure protection circuit, an address coding circuit, and a display alarming circuit.

10 The main part of the theft detection module is an oscillating circuit. The feedback of the circuit connects to the current detection circuit in the power supply circuit. The oscillating circuit will work normally if there is no theft; but if any theft occurs, the oscillating will cease because no feed back signal being carried on. The single chip microcomputer will detect the tapping of power immediately, and know how to handle it.

15 Accordingly, embodiments of the invention employ software to do one or more the following:

- 20 1. Manage basic data of the power users; handle inside code and outside address of the meter, handle customer's address, name, tariff deposit, accumulated deposit, the total consumed watt-hours, the watt-hours available; provide the reason for each power cutoff; handle the way and the date of the penalty executed as well as the amount of the time; and the payment.
- 25 2. Put the user's tariff deposit into the computer, with respect to his/her account number, and then send that deposit information to the user's individual meter and store it there.
3. Scan the meter in the covered region sequentially, collect consumed watt-hours, make theft mark and record the time the theft occurred.
- 30 4. Resume power supply, via the control centre, to the illegal customer after the penalty paid or the deposit made. In short, the centre automatically switches the meter to an "on" or "off" position for the certain user and erases the theft mark, the time record, and the alarming tag during resumption.

5. Scan out a disabled meter, record the problem, and then inform the operators.

6. Send messages to all meters managed in the covered area by broadcasting set settings, including real time clock, time-on-load separation, and power limitation definition.

5 7. Analyze statistics of working meters at different levels, detect whether the power lost is due to reasonable or illegal usage.

8. Execute, through the control centre, short, medium or long term statistics on user's record and send to upper management offices.

10 Accordingly, embodiments of the invention employ the Interactive Meter to achieve the following:

1. Each meter has a special address code can be accessed by the control centre as a certain address, and the common address is accessible on the system broadcasting.

15 2. The meter will keep low power consumption if it stays on a communication standby and sends no messages out. It receives only system messages under system broadcasting, but will receive and store messages first, then send out data back to the caller during conversion. The power consumption will stay high while the meter sends out data.

20 3. Watt-hours counting depends on load critical time of a day. There are 10 time sections available. Time separation definition can be set on system broadcasting data, including a real-time clock, the total number of time sections, the start and stop of each time section, the rank of each time section, and the unit price of each time section.

25 4. On the 10 time section, the counting precision is no lower than 1/256 (one byte for decimal number); the maximum watt-hours that can be storage is 16777216 kwh; the length of watt-hours display is four digits.

30 5. The computer on the control centre sends the user's deposit to his/her meter, the consumed watt-hours will be converted into money to compare with the deposit value. If the consumption reaches the deposit for a certain value, the meter will alarm. The user can push the alarm reset button to stop the alarm when he/she recognizes that the alarm has been tripped, but the time he/she pushed the button will be recorded in the meter to show that the user already knows the alarm has gone off. If the user's deposit is exceeded, the meter will cut-off the power supply line. In such

a situation, the user cannot resume power. The only way for the user to solve the problem is to pay the tariff so that the control centre will resupply the power. The meter can also be set on an use-then-pay setup while customer will pay periodically according to actual consumption.

- 5 6. The meter automatically tests the phase difference between voltage and current and calculates the power factor.
7. If the user steals power, the meter will first alarm for a pre-set period of time and then cut-off the power supply and record the theft, the date, and time. The power supply will be resumed after the illegal action have been dealt with.
- 10 8. The data stored in the meter cannot be lost or erased, even if power supply is cut-off. The data will continue to affect meter operation immediately after power resumption.
9. The meter controls its maximum power limitation by the data transferred from control centre.
- 15 10. There are different kinds of meters available such as a single and multi-phase or high, medium, and lower power.

The invention will now be described by way of example with reference to the accompanying drawings, throughout which like parts are referred to by like references, and in which:

20 Figure 1 is a schematic diagram of the structure of an embodiment of the present invention.

Figure 2 is a schematic diagram of the meter structure of an embodiment of the present invention.

25 Figure 3 is a schematic diagram of the meter PCB board of an embodiment of the present invention.

Figure 4 is a schematic functional diagram of the meter of an embodiment of the present invention.

Figure 5 is a flow diagram of the control centre software of an embodiment of the present invention.

30 Figure 6 is a flow chart of the meter software of an embodiment of the present invention.

Figure 7 is a schematic diagram of the thief detection module in the meter of

an embodiment of the present invention.

In one preferred embodiment of the present invention, as shown in Figure 1, a personal computer serves as a control centre computer 1 operating software according to the software flowchart as shown in Figure 5. The control centre computer 1 is connected to a communication controller 3 in the data transferring mechanism with a cable 2. The communication controller 3 consists of a transmitter and a receiver with modems and insulators, or civil and common power supply system data communication medium 4 serve as AC power supply lines whereby data is modulated, demodulated and transferred through common power supply lines.

As shown in Figure 2, the interactive power meter 5 is composed of a meter case 6, a data display part 7 and a meter PCB board 8. A buzzer 9, a display selection button 10, and an alarm reset button 11 are designed on the face of the interactive power meter case 6.

As shown in Figure 3, on the PCB board 8, there is a single chip microcomputer 12, program storage 13, data memory 14, a transmitting module 15, a receiver module 16, A/D and D/A converter module 17, a thief control and power line balance detection module 18, and power supply module 19.

The systems works as follows:

After meters are installed, the computer at the control centre will first recognize it. After the user makes a deposit, the computer will set the meter; that is, to define the counting and power limitation. Then, the computer switches on the meter so as to let the meter work.

During non-critical time, the central computer will run a maintenance program to check the states of power supply network and every meter. It will record them for management supervisors. At the data collection period, the central computer runs a data collection program. The computer calls each meter to collect data and put the data into record file through a polling method.

If the watt-hour charging standard, e.g. the time section or price, needs to be changed, the system will set all meters in the covered region on the system broadcasting. To insure that the timing and charging are correct, the central computer will adjust the real-time clock of every meter by broadcasting.

After data collection and diagnostic execution, the central computer runs

statistics on the record data to detect illegal users and disordered meters. A printout of such information can be printed if required.

Figure 4 is a schematic functional diagram of the meter of Figures 2 and 3.

5 In Figure 4, the input power supply is supplied to a thief detection circuit 18, a voltage measurement circuit 30 and a current measurement circuit 32. Output power, to the supplies to the consumer or to a next stage of the metering network is supplied from the thief detection circuit 18.

10 The current measure circuit 32 and the voltage measurement circuit 30 generate outputs indicative of the current and voltage being drawn at any particular time, which outputs are effectively multiplied by a power count circuit 34 to detect the power consumption at that time. The output of the power count circuit 34 is supplied to the single chip computer 12.

15 The single chip computer 12 communicates with the thief detection circuit 18, a display and alarm circuit 36, which operates the data display 7 and the buzzer 9 of Figure 2, an address code circuit which stores an address which is indicative of the particular meter (in a network of such meters, the address of each meter would be unique), and a power failure protection circuit 40 which provides a backup power supply to the single chip computer 12 in case the main power supply fails.

20 The single chip computer 12 and the power failure protection circuit 40 are also connected to a communication control circuit 42 which communicates with the control centre computer 1 through the power lines, through special communication lines, optical fibres and/or via radio waves. Power line communication is suitable for civil and general power supply applications. Dedicated communication lines and radio wave communication are suitable for situations in which high quality signal demands are required, or power line data transfer is limited. In the embodiment shown in Figure 4, the communication control circuit is connected to the power supply lines, to communication via those lines using known techniques.

25
30 If data is to be transmitted to or from the meter of Figure 4, that data would be accompanied by an address section specifying the particular meter to which the data is addressed. When such data is received, the single chip computer compares the address section with the address stored in the address code circuit 38 and, if the two addresses match, the accompanying data is intended for that particular meter.

Figure 5 is a flow diagram illustrating the control centre software running on the control centre computer 1.

At a step 50, the control centre computer initialises itself for operation with the network of meters.

5 At a step 52, the control centre computer performs system diagnosis, in which it polls each meter to check the current status of that meter. If a meter returns an indication that the meter is faulty that indication is stored in a faulty meter record file 54.

10 At a step 56, the control centre computer selects one of the following functions, listed by respective step numbers on Figure 5:

58, data collection, in which the control centre computer retrieves power consumption records from one or more of the meters, to be stored in a power consumption record file 60;

15 62, tariff collection management, in which tariffs are obtained from the electricity's provider or retailer to be stored in a tariff record file 64. Data from the tariff record file is also used in step 66, meter setting, in which the tariffs are transmitted to all of the meters;

20 68, statistics management, in which the consumption records are checked throughout the network structure to ensure that consumption figures for meters higher in the network hierarchy match the sum of the respective consumptions for meters lower in the network hierarchy. This check is performed to detect theft of electricity;

70, query management, in which queries from an operator of the control centre computer 1 are handled (such as power consumption records for particular meters);

25 72, list print control, in which data stored in the faulty meter record file, the power consumption record file and/or the tariff record file can be printed out for the operator of the control centre computer 1;

74, system maintenance, in which, for example, faulty meters can be re-initialised;

76, exit from the program running on the control centre computer 1.

30 Figure 6 is a flowchart of meter software running on the single chip computer 12 of each meter.

The first stage of operation is an initialisation process 80. After that, the meter

accepts instructions from the control centre computer 1, at a step 82. These instructions can initiate the following meter functions, listed below by the respective step numbers on Figure 6:

84: the supply to the output of the meter can be turned on or off;

5 86, parameter setting;

88, transmit consumptions and charge data to the control centre computer 1;

90, sends meter state data (such as fault information) to the control centre computer 1;

10 92, sets the internal clock of the meter (operated by the single chip computer 12); and

94, alarm control, in which the meter is instructed to use the display and alarm circuit 36 to sound an alarm at the meter.

15 Figure 7 is a schematic diagram of a theft detection circuit 18, which in fact comprises an oscillating circuit 96 connected to the current measurement circuit 32. The oscillating circuit 96 uses the current measuring circuit 32 as part of its feedback loop. If the current measuring circuit is disabled for any reason (e.g. by a thief), the feedback is cut-off and the oscillation stops. This is detected by the oscillating circuit 96, to generate a thief alarm signal to be supplied to the single chip computer 12.

20 The meters are be mounted on topological structures, as represented in Figure 8. The theft, which occurs in front of the user's meter, could also be detected by statistics. For example, a thief acts at a power line before meter A1', The statistics will show that the watt-hour summary on meter A1' and A2' will not equal to meter A1. Furthermore, if a thief acts in front of the meter An, the watt-hours on meter A will not equal to summary A1, A2,An. In this way, theft will be detected.

25 Power leakage could also be detected by the same method.

30 When a theft occurs, an alarm on the meter will be triggered and sound for a minute, and if the action continues, the meter will cut off the power supply to the user and will make a record of the incident. The power supply administration will be informed of the theft, and the user will receive his penalty. If the user continues to steal power from the power lines, he/she will be punished again because the control centre is already aware of the occurrences. After the theft has been detected and the matter has been resolves, the power supply is resumed.

In short, after being initiated by the central computer, the meters are activated. Each meter will alarm if the deposit is exceeded. Users can push the alarm reset button to stop the alarm from sounding, but the record of the theft is made of permanent record in the computer already.

5 In a second embodiment of the present invention, the structure and execution are the same as just described, but the communication medium selected are telephone lines, optical fibres or special data communication lines.

10 In a third embodiment of the present invention, the structure and execution are the same as the first and second embodiment, except that the communication medium selected are radio channels.

In summary, the embodiment described above can perform one or more of the following:

1. Manage basic data of the power users; handle inside code and outside address of the meter, handle customer's address, name, tariff deposit, accumulated deposit, the total consumed watt-hours, the watt-hours available; provide the reason for each power cutoff; handle the way and the date of the penalty executed as well as the amount of the time; and the payment.
2. Put the user's tariff deposit into the computer, with respect to his/her account number, and then send that deposit information to the user's individual meter and store it there.
3. Scan the meter in the covered region sequentially, collect consumed watt-hours, make theft mark and record the time the theft occurred.
4. Resume power supply, via the control centre, to the illegal customer after the penalty paid or the deposit made. In short, the centre automatically switches the meter to an "on" or "off" position for the certain user and erases the theft mark, the time record, and the alarming tag during resumption.
5. Scan out a disabled meter, record the problem, and then inform the operators.
6. Send messages to all meters managed in the covered area by broadcasting set settings, including real time clock, time-on-load separation, and power limitation definition.
7. Analyze statistics of working meters at different levels, detect whether the power lost is due to reasonable or illegal usage.

8. Execute, through the control centre, short medium or long term statistics on user's record and send to upper management offices.

The interactive meter described above can achieve the following:

1. Each meter has a special address code can be accessed by the control centre as a certain address, and the common address is accessible on the system broadcasting.

2. The meter will keep low power consumption if it stays on a communication standby and sends no messages out. It receives only system messages under system broadcasting, but will receive and store messages first, then send out data back to the caller during conversion. The power consumption will stay high while the meter sends out data.

3. Watt-hours counting depends on load critical time of a day. There are 10 time sections available. Time separation definition can be set on system broadcasting data, including a real-time clock, the total number of time sections, the start and stop of each time section, the rank of each time section, and the unit price of each time section.

4. On the 10 time section, the counting precision is no lower than $1/256$ (one byte for decimal number); the maximum watt-hours that can be storage is 16777216 kwh; the length of watt-hours display is four digits.

5. The computer on the control centre sends the user's deposit to his/her meter, the consumed watt-hours will be converted into money to compare with the deposit value. If the consumption reaches the deposit for a certain value, the meter will alarm. The user can push the alarm reset button to stop the alarm when he/she recognizes that the alarm has been tripped, but the time he/she pushed the button will be recorded in the meter to show that the user already knows the alarm has gone off.

If the user's deposit is exceeded, the meter will cut-off the power supply line. In such a situation, the user cannot resume power. The only way for the user to solve the problem is to pay the tariff so that the control centre will resupply the power. The meter can also be set on an use-then-pay setup while customer will pay periodically according to actual consumption.

6. The meter automatically tests the phase difference between voltage and current and calculates the power factor.

7. If the user steals power, the meter will first alarm for a minute and then cut-

off the power supply and record the theft, the date, and time. The power supply will be resumed after the illegal action have been dealt with.

8. The data stored in the meter cannot be lost or erased, even if power supply is cut-off. The data will continue to affect meter operation immediately after power
5 resumption.

9. The meter controls its maximum power limitation by the data transferred from control centre.

10. There are different kinds of meters available such as a single and multi-phase or high, medium, and lower power.

10 In summary, an interactive power consumption control and evaluation system comprises a central control computer with management software and a group of communication controllers consisting of transmitters, receivers, and modems and insulators. The communication controller connects to a data exchanger in the user's
15 interactive power meter which comprises a meter case, a data display, and a PCB board. A buzzer, a select button, and an alarm reset button are designed on the face of the meter case. On the PCB board, there is a single chip microcomputer, program storage, data memory, a transmitter and receiver module, an A/D and D/A conversion module, a theft control, a power line balance detection module, as well as a power supply module. The system addresses many problems in current power supply
20 management and is effective total automatic power supply management system with a computer network.

CLAIMS

1. An interactive power consumption control and evaluation system comprising a central controller, a power consumption data transfer mechanism and a series interactive power consumption meters, wherein

5 said central controller has of a set of computers with management software, a communication controller connected with cables,

said power consumption data transfer mechanism has said communication controller and data transfer media,

10 said communication controller has a transmitter and receiver which includes modems and insulators,

said communication controller is connected with a data communication part inside said power consumption meters through communication medium,

the system network structure is a star-shape,

15 said interactive power consumption meter has a case, a data display part, a meter PCB board, a single chip microcomputer, program storage, data memory, said transmitter and receiver, an A/D and D/A module, a theft control and power line balance detection module, and a power supply module.

20 2. An interactive power consumption control and evaluation system as claimed in claim 1, wherein said communication medium comprises at least one of: a power line, a special communication line, a radio or optical fibre.

25 3. An interactive power consumption control and evaluation system as claimed in claim 1, wherein said interactive power consumption meter and said power line balance detection module contains an oscillating circuit connecting to a power supply line.

30 4. An interactive power consumption control and evaluation system as claimed in claim 2, wherein said intelligent power consumption meter and said power line balance detection module contains an oscillating circuit connecting to a power supply line.

5. A power consumption detection system comprising:
a plurality of consumer power consumption meters, each meter having means for measuring electrical power consumption, means for communicating with a control apparatus, and means for controlling the supply of power to a consumer in response to meter control commands received from the control apparatus; and
5 a control apparatus having means for communicating with each power consumption meter and means for issuing meter control commands to at least one of the meters to control the supply of power to a consumer via that meter.
- 10 6. A system according to claim 5, in which each meter comprises:
means for detecting unauthorised electricity consumption not measured by the measuring means.
- 15 7. A system according to claim 6, in which each meter comprises:
means for transmitting a theft alarm signal to the control apparatus when unauthorised electricity consumption is detected.
- 20 8. A system according to claim 6 or claim 7, in which each meter comprises an alarm sounder for generating an audible alarm when unauthorised power consumption is detected.
- 25 9. A system according to any one of claims 6 to 8, in which each meter comprises means for stopping power delivery by that meter when unauthorised power consumption is detected.
- 30 10. A system according to any one of claims 6 to 9, in which the unauthorised power consumption detecting means comprises an oscillator circuit having an oscillator feedback path through the power consumption detecting means so that oscillation is not possible if the power consumption detecting means is disabled; and means for detecting whether oscillation of the oscillator circuit is taking place.
11. A system according to any one of claims 6 to 9, comprising one or more

master power meters connected to supply power to respective groups of the consumer meters; and in which the unauthorised power detecting means comprises means for comparing a sum of the power consumption detected by the consumer meters in a group with the power consumption detected by the master power meter for that group.

5

12. A system according to any one of claims 5 to 11, in which each meter comprises:

means for detecting a product of the power consumption and a tariff rate for the current time;

10

means for generating data indicative of a cumulative power charge based on the product measurement; and

means, responsive to a request issued by the control apparatus, for transmitting the cumulative power charge data to the control apparatus.

15

13. A power consumption meter comprising:

means for measuring electrical power consumption, means for communicating with a control apparatus, and means for controlling the supply of power to a consumer in response to meter control commands received from a control apparatus.

20

14. A power consumption control apparatus having means for communicating with each of a plurality of power consumption meters and means for issuing meter control commands to at least one of the meters to control the supply of power to a consumer via that meter.

25

15. A power consumption detection system substantially as hereinbefore described with reference to the accompanying drawings.

16. A power consumption meter substantially as hereinbefore described with reference to the accompanying drawings.

30

17. A power consumption control apparatus substantially as hereinbefore described with reference to the accompanying drawings.



Application No: GB 9513811.1
Claims searched: 5 to 14,16 and 17

Examiner: Ken Long
Date of search: 25 March 1996

Patents Act 1977
Further Search Report under Section 17

Databases searched:

UK Patent Office collections, including GB, EP, WO & US patent specifications, in:

G1U (UR1124, G1U (UR1124, UR1160, UR21133 & UR2200)
UR1160, UR21133
& UR2200)UK CI
(Ed.O):

G01R (11/24, G01R (11/24, 11/60, 21/133 & 22/00)
11/60, 21/133 &
22/00)Int CI
(Ed.6):

Other: Online: WPI

Documents considered to be relevant:

Table with 3 columns: Category, Identity of document and relevant passage, Relevant to claims. Rows include GB 2245372 A, GB 1564255, GB 1543501, GB 1535835, GB 1527507, and US 4803632.

Legend table explaining symbols: X Document indicating lack of novelty or inventive step, Y Document indicating lack of inventive step if combined with one or more other documents of same category, & Member of the same patent family, A Document indicating technological background and/or state of the art, P Document published on or after the declared priority date but before the filing date of this invention, E Patent document published on or after, but with priority date earlier than, the filing date of this application.



Application No: GB 9513811.1
Claims searched: 1 to 4 and 15

Examiner: Ken Long
Date of search: 19 September 1995

Patents Act 1977
Search Report under Section 17

Databases searched:

UK Patent Office collections, including GB, EP, WO & US patent specifications, in:

UK CI (Ed.N): G1U (UR1124 & UR21133)

Int CI (Ed.6): G01R (11/24 AND 21/133-)

Other: Online: WPI

Documents considered to be relevant:

Category	Identity of document and relevant passage	Relevant to claims
A	GB 2280960 A Siemens Measurements- page 2 lines 6-9 and page 3 lines 13-16	None
A	GB 2245372 A Ampy Automation Digilog- page 1 lines 2-10 and page 3 lines 18-29	None
X	US 4803632 Utility Systems- column 1 lines 24-28, column 8 lines 7 to 13, column 4 lines 51-55, column 10 lines 20-23 and line 6 of Table I.	1,2,5-9 & 12-14

X Document indicating lack of novelty or inventive step
 Y Document indicating lack of inventive step if combined with one or more other documents of same category.
 & Member of the same patent family

A Document indicating technological background and/or state of the art.
 P Document published on or after the declared priority date but before the filing date of this invention.
 E Patent document published on or after, but with priority date earlier than, the filing date of this application.