



US00D868668S

(12) **United States Design Patent**
Parvzian et al.

(10) **Patent No.:** **US D868,668 S**

(45) **Date of Patent:** **** Dec. 3, 2019**

(54) **AIRCRAFT**

(71) Applicant: **volans-i, Inc.**, San Francisco, CA (US)

(72) Inventors: **Hannan Parvzian**, San Francisco, CA (US); **Guangyuan Zheng**, San Francisco, CA (US); **Manuel Lopez**, Richmond, CA (US)

(73) Assignee: **volans-i, Inc.**, San Francisco, CA (US)

(**) Term: **15 Years**

(21) Appl. No.: **29/660,597**

(22) Filed: **Aug. 22, 2018**

(51) **LOC (12) Cl.** **12-06**

(52) **U.S. Cl.**
USPC **D12/328**

(58) **Field of Classification Search**
USPC D12/1-4, 16.1, 319-345; D21/436-454
CPC B64C 39/024; B64C 13/16; B64C 19/00;
B64C 2201/021; B64C 2201/141; B60H
1/3442
See application file for complete search history.

(56) **References Cited**

U.S. PATENT DOCUMENTS

D91,444 S *	1/1934	Shelton	D12/335
D97,652 S *	11/1935	Swanson	D12/335
D98,660 S *	2/1936	Burnelli	D12/335
D100,608 S *	7/1936	Taylor et al.	D12/335
D100,609 S *	7/1936	Wilson et al.	D12/335
D102,870 S *	1/1937	Brethen et al.	D21/450
D114,626 S *	5/1939	Taylor et al.	D12/335
D119,319 S *	3/1940	Johnstone et al.	D12/335
D119,714 S *	3/1940	Hibbard et al.	D12/335
D126,067 S *	3/1941	Boushey	D12/335
D129,412 S *	9/1941	Nebesar	D12/324
RE22,029 E *	2/1942	Nebesar	B64C 39/04
				D12/335
D138,217 S *	7/1944	Van Zelm	D12/335

D138,218 S *	7/1944	Van Zelm	D12/335
D138,795 S *	9/1944	Stoughton	D12/335
D139,028 S *	10/1944	Stout	D12/335
D139,438 S *	11/1944	Hughes et al.	D12/335
D140,113 S *	1/1945	Biasell	D12/335
D143,731 S *	2/1946	Hall et al.	D12/335
D143,732 S *	2/1946	Hall et al.	D12/335
D143,820 S *	2/1946	Hibbard et al.	D12/335
D144,211 S *	3/1946	Northrop et al.	D12/335
D144,938 S *	6/1946	Schmued	D12/335
D148,595 S *	2/1948	Thieblot	D12/335
D157,645 S *	3/1950	Thieblot	D12/335
D159,110 S *	6/1950	Thieblot	D12/335
D159,198 S *	7/1950	Greenwood et al.	D12/335

(Continued)

OTHER PUBLICATIONS

Hybrid VTOL manufacturer Volans-i. by Press. dated May 17, 2019. found online [Jul. 20, 2019] <https://www.suasnews.com/2019/05/hybrid-vtol-manufacturer-volans-i-raises-20-million-series-a-funding/>.

(Continued)

Primary Examiner — Marissa J Cash
(74) *Attorney, Agent, or Firm* — Cognition IP, P.C.; Bryant Lee

(57) **CLAIM**

The ornamental design for an aircraft, as shown and described.

DESCRIPTION

FIG. 1 is a top perspective view of an aircraft showing my new design;
FIG. 2 is a top plan view thereof;
FIG. 3 is a bottom plan view thereof;
FIG. 4 is a rear elevation view thereof;
FIG. 5 is a front elevation view thereof;
FIG. 6 is a right side elevation view thereof; and,
FIG. 7 is a left side elevation view thereof.

1 Claim, 5 Drawing Sheets

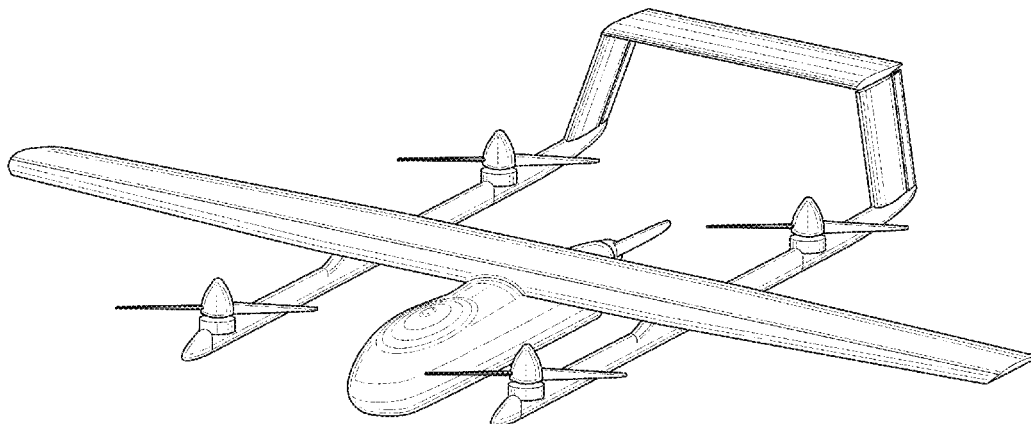

(56)

References Cited

U.S. PATENT DOCUMENTS

D160,841 S * 11/1950 Burnelli D12/335
 D162,517 S * 3/1951 Burnelli D12/335
 D163,722 S * 6/1951 Vinje D12/4
 D176,839 S * 2/1956 Custer D12/339
 2,752,114 A * 6/1956 Calvy B60J 5/125
 244/118.3
 2,989,269 A * 6/1961 Le Bel B64C 29/0033
 244/12.3
 D192,195 S * 2/1962 Stephniewski D12/330
 D192,337 S * 3/1962 Skaggs D12/4
 D192,665 S * 4/1962 Stephniewski D12/335
 D197,933 S * 4/1964 Sumner D12/324
 D203,283 S * 12/1965 Woods D21/448
 D203,720 S * 2/1966 Jarchow D12/335
 D210,809 S * 4/1968 Stearman D12/335
 D239,274 S * 3/1976 Snyder D12/335
 D239,522 S * 4/1976 Wheatly D12/335
 D273,005 S * 3/1984 McComas D12/335
 4,746,082 A * 5/1988 Syms B64D 47/08
 244/118.2
 D308,043 S * 5/1990 Butler D12/331
 D311,720 S * 10/1990 Butler D12/331
 D312,068 S * 11/1990 Moller D12/319
 D319,805 S * 9/1991 Wiegert D12/319
 5,115,996 A * 5/1992 Moller B64C 29/0025
 239/265.19
 D381,952 S * 8/1997 Carter, Jr. D12/327
 D446,182 S * 8/2001 Adam, Jr. D12/319
 D498,201 S 11/2004 Moller
 D500,729 S * 1/2005 Wilding D12/319
 D500,981 S * 1/2005 Wilding D12/319

D543,248 S * 5/2007 Winston D21/450
 D559,329 S * 1/2008 Connally D21/447
 D597,472 S * 8/2009 Cazals D12/319
 7,967,246 B2 * 6/2011 Chan B60V 1/08
 244/100 A
 D665,333 S 8/2012 Oliver
 D732,458 S * 6/2015 Dutertre D12/319
 D736,140 S * 8/2015 Moller D12/326
 9,120,560 B1 9/2015 Armer et al.
 D741,247 S 10/2015 Brody
 D743,868 S * 11/2015 Cummings D12/328
 9,783,288 B1 * 10/2017 Moore B64C 27/24
 9,845,150 B2 * 12/2017 Kroo B64C 3/56
 D808,328 S * 1/2018 Ivans D12/328
 9,898,033 B1 * 2/2018 Long G01D 5/145
 9,957,035 B2 * 5/2018 Valasek B64C 1/22
 D843,305 S * 3/2019 MacAndrew D12/319
 D843,306 S * 3/2019 Tzarnotzky D12/329
 D843,919 S * 3/2019 Tzarnotzky D12/329
 10,259,563 B2 * 4/2019 Long B64C 11/02
 D852,092 S * 6/2019 Woodworth D12/16.1
 2004/0245374 A1 12/2004 Morgan
 2009/0008499 A1 1/2009 Shaw
 2016/0244158 A1 * 8/2016 Fredericks B64C 25/52
 2017/0210481 A1 * 7/2017 Bak B64D 27/24
 2017/0300067 A1 * 10/2017 Douglas B64C 29/0025
 2018/0290735 A1 * 10/2018 Uptigrove B64D 35/04

OTHER PUBLICATIONS

Volans-i Raises \$20 Million . by Dee ann Divis. dated May 22, 2019. found online [Jul. 20, 2019] <http://insideunmannedsystems.com/volans-i-raises-20-million-in-series-a-funding/>.*

* cited by examiner

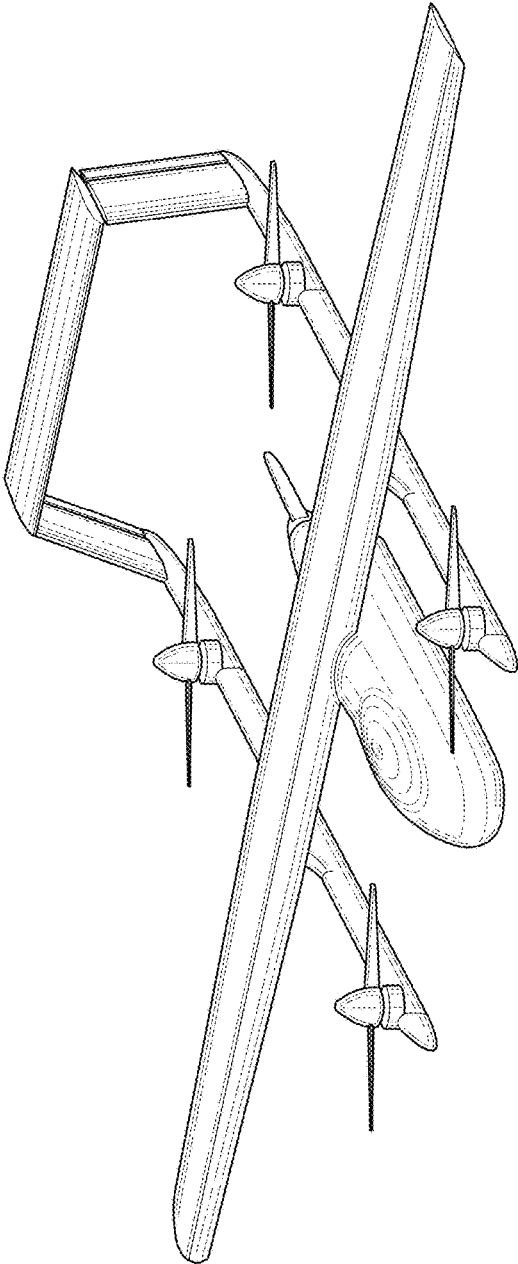

FIG. 1

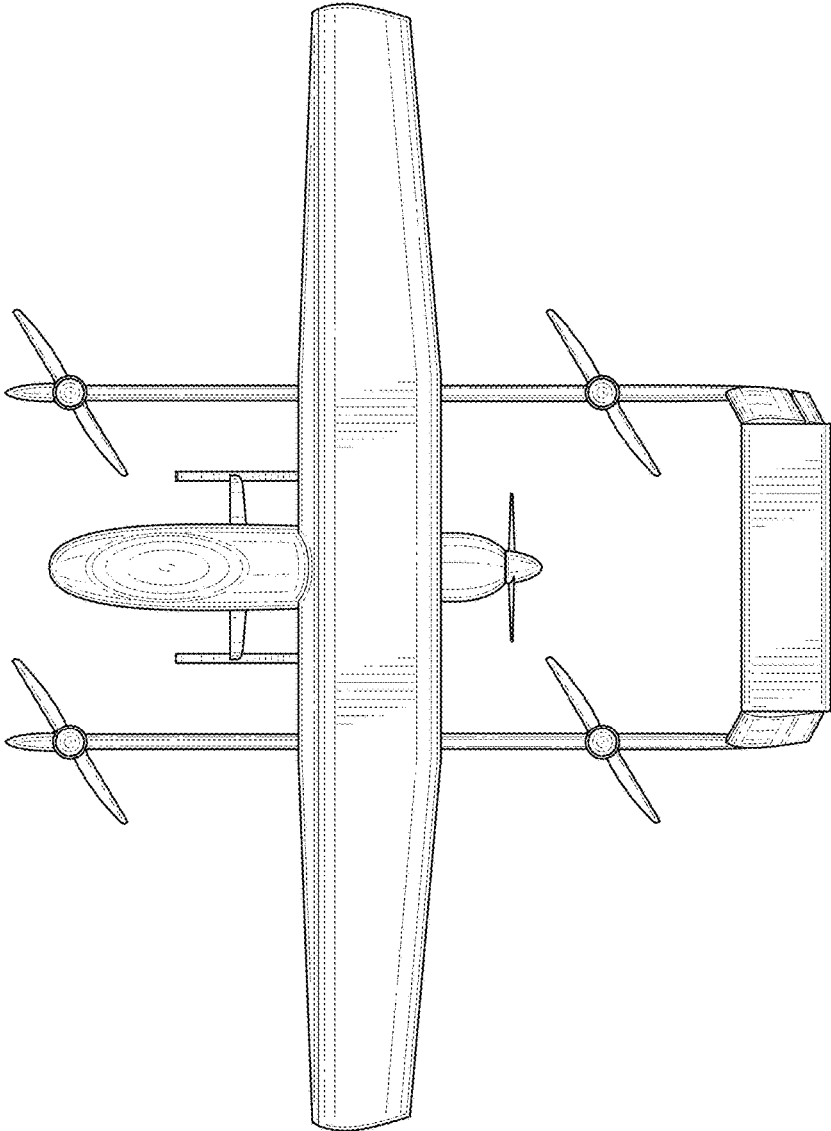

FIG. 2

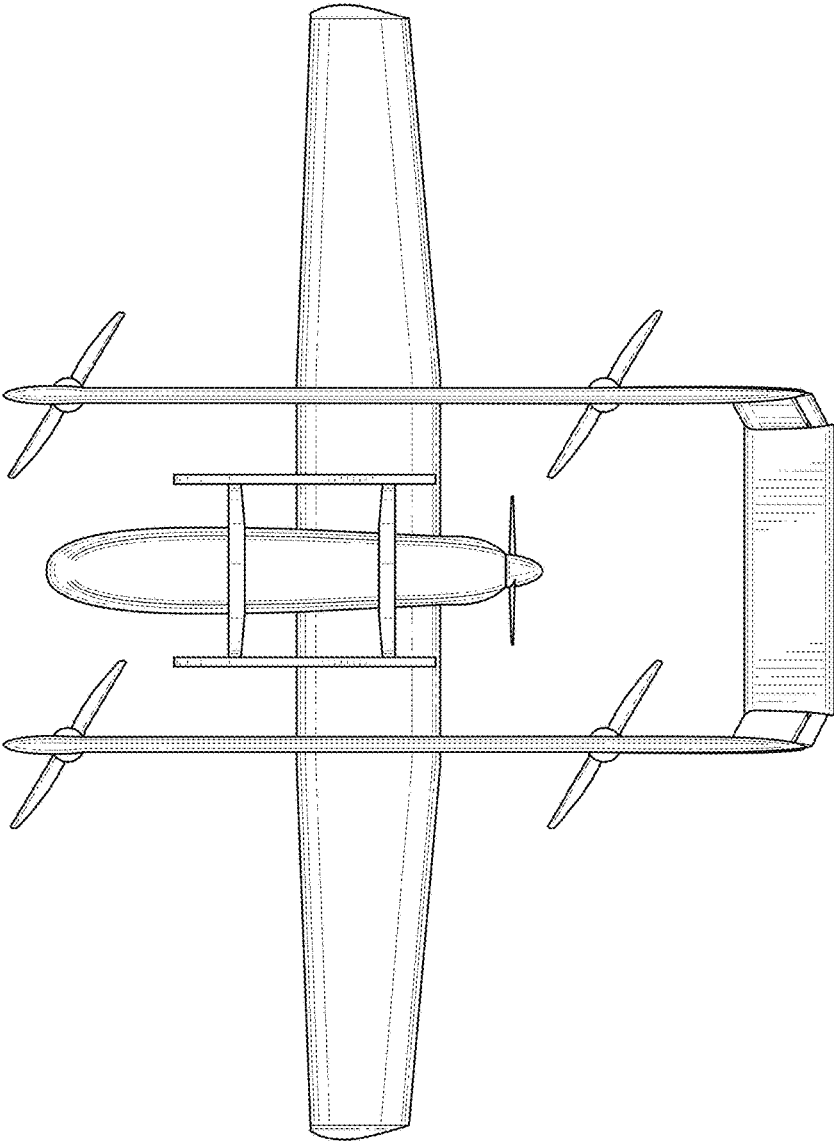

FIG. 3

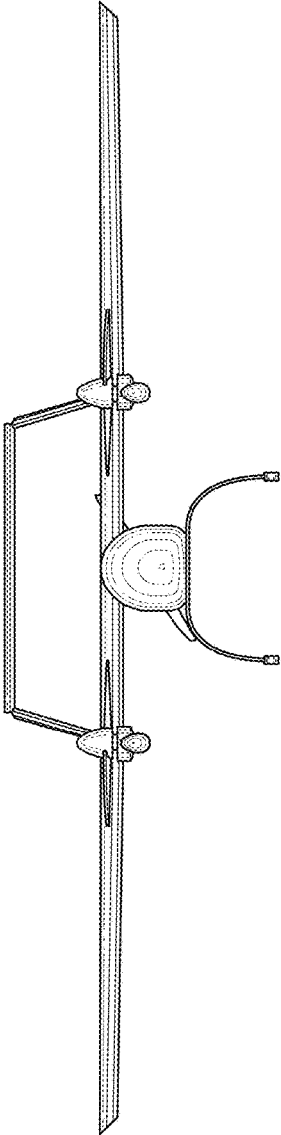

FIG. 4

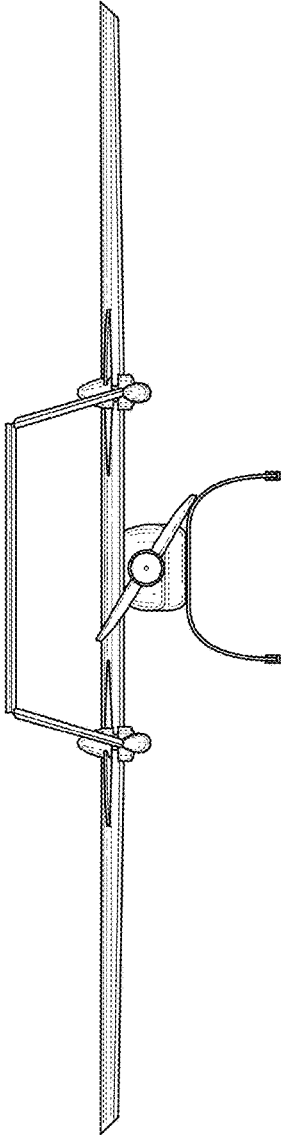

FIG. 5

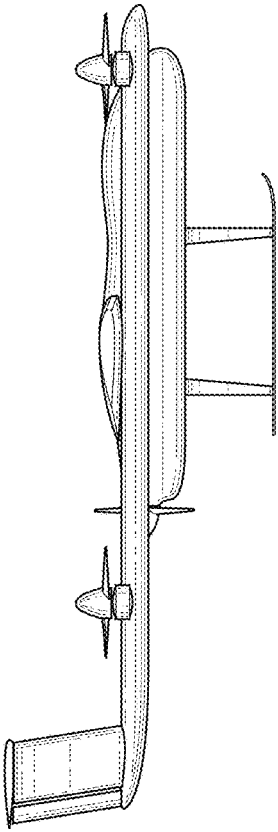

FIG. 6

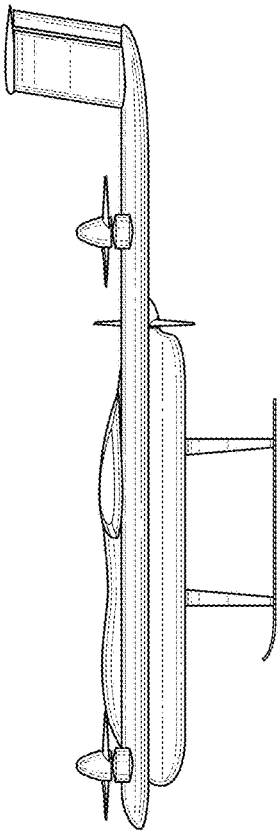

FIG. 7