

(12) **United States Design Patent** (10) **Patent No.:** **US D807,936 S**
He et al. (45) **Date of Patent:** **** Jan. 16, 2018**

(54) **ROBOTIC JOINT**

(71) Applicant: **ENGINEERING SERVICES INC.**,
Markham, ON (CA)

(72) Inventors: **Xiaojia He**, Toronto (CA); **Ziren Lu**,
Thornhill (CA); **Andrew A. Goldenberg**, Toronto (CA)

(73) Assignee: **ENGINEERING SERVICES INC.**,
Toronto, ON (CA)

(**) Term: **15 Years**

(21) Appl. No.: **29/602,024**

(22) Filed: **Apr. 27, 2017**

(51) **LOC (11) Cl.** **15-99**

(52) **U.S. Cl.**
USPC **D15/199; D15/138**

(58) **Field of Classification Search**
USPC D15/199; D21/578-583, 621, 622;
D23/259, 262, 263
CPC B25J 9/104; B25J 17/0275; B25J 17/0283;
Y10T 74/19; Y10T 74/20305; Y10T
74/20311; Y10T 74/20317; Y10T
74/20323; Y10T 74/20329; Y10T
403/32041
See application file for complete search history.

D709,933 S * 7/2014 Wu D15/143
D740,371 S * 10/2015 Ries D21/333
D776,178 S * 1/2017 Ries D15/199
D781,943 S * 3/2017 Ries D15/148
2002/0056326 A1* 5/2002 Gombert G01L 5/166
73/862.046
2011/0232411 A1* 9/2011 Long B25J 17/0258
74/490.05
2011/0265597 A1* 11/2011 Long B25J 9/102
74/490.05
2012/0048051 A1* 3/2012 Long B25J 19/0054
74/490.03
2012/0067148 A1* 3/2012 Long F16H 1/22
74/412 R
2012/0085191 A1* 4/2012 Long B25J 17/02
74/423
2013/0118286 A1* 5/2013 Long B25J 17/0283
74/490.01
2013/0125694 A1* 5/2013 Long B25J 11/0075
74/490.01
2013/0125696 A1* 5/2013 Long B25J 18/04
74/490.05

(Continued)

Primary Examiner — Patricia A Palasik
(74) *Attorney, Agent, or Firm* — Hill & Schumacher

(57) **CLAIM**

The ornamental design for a robotic joint, as shown and described.

DESCRIPTION

FIG. 1 is perspective view of the robotic joint showing our new design;
FIG. 2 is a front view thereof;
FIG. 3 is a right side view thereof;
FIG. 4 is a top view thereof;
FIG. 5 is a rear view thereof; and,
FIG. 6 is bottom view thereof.
The broken lines in the drawings depict unclaimed environmental subject matter.

1 Claim, 3 Drawing Sheets

(56) **References Cited**
U.S. PATENT DOCUMENTS

D56,926 S * 1/1921 Reiland et al. D23/263
D370,964 S * 6/1996 Horvath D23/262
6,084,373 A * 7/2000 Goldenberg B25J 9/08
318/568.11
D634,818 S * 3/2011 Leroyer D23/263
D676,941 S * 2/2013 Kluss D23/262
8,525,460 B2 * 9/2013 Reiland B25J 9/1641
267/277

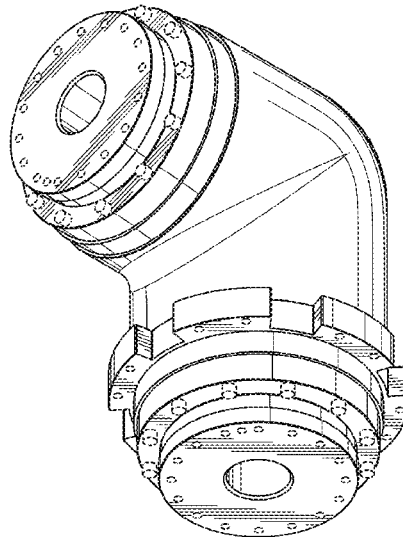

(56)

References Cited

U.S. PATENT DOCUMENTS

| | | | | |
|--------------|-----|---------|---------------|--------------------------|
| 2013/0145891 | A1* | 6/2013 | Long | B25J 18/00 74/490.02 |
| 2014/0116182 | A1* | 5/2014 | Long | B25J 9/102 74/490.04 |
| 2014/0338490 | A1* | 11/2014 | Shinabe | B23P 15/00 74/490.03 |
| 2015/0251322 | A1* | 9/2015 | Goodwin | B25J 11/008 74/490.03 |
| 2016/0061367 | A1* | 3/2016 | Smith | F16L 25/00 285/179.1 |

* cited by examiner

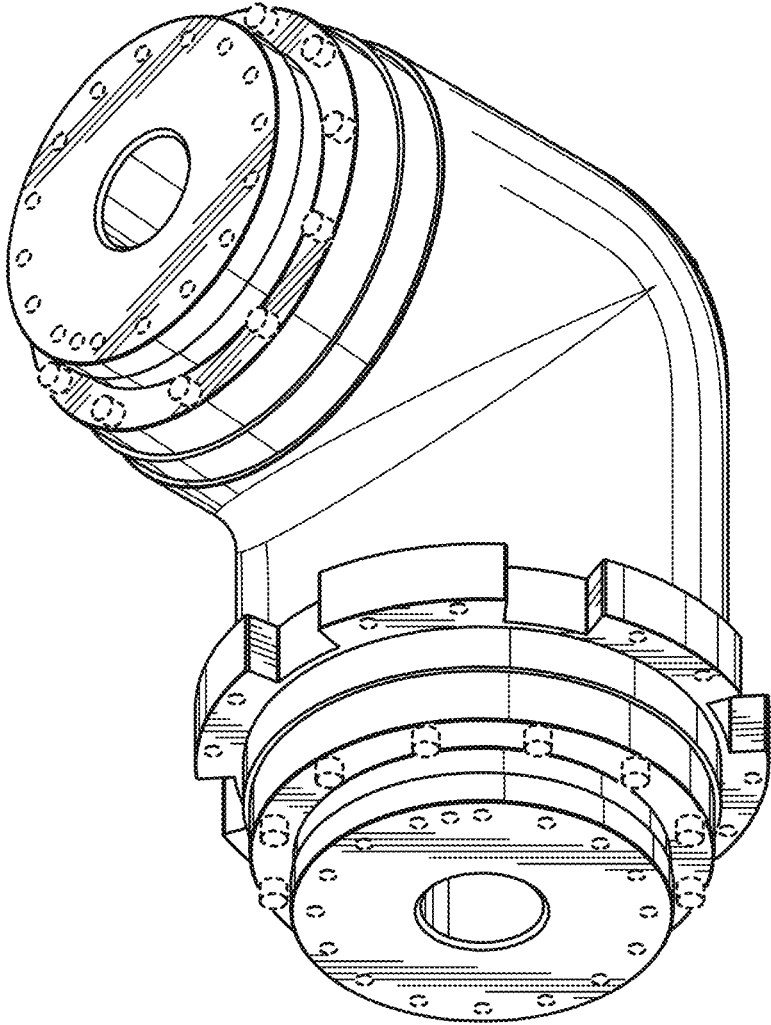

FIG. 1

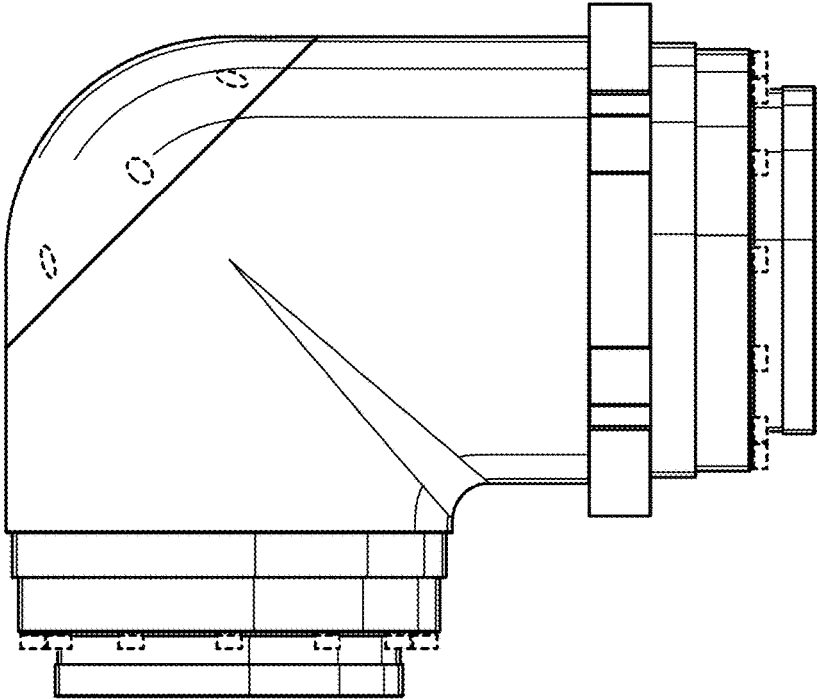

FIG. 2

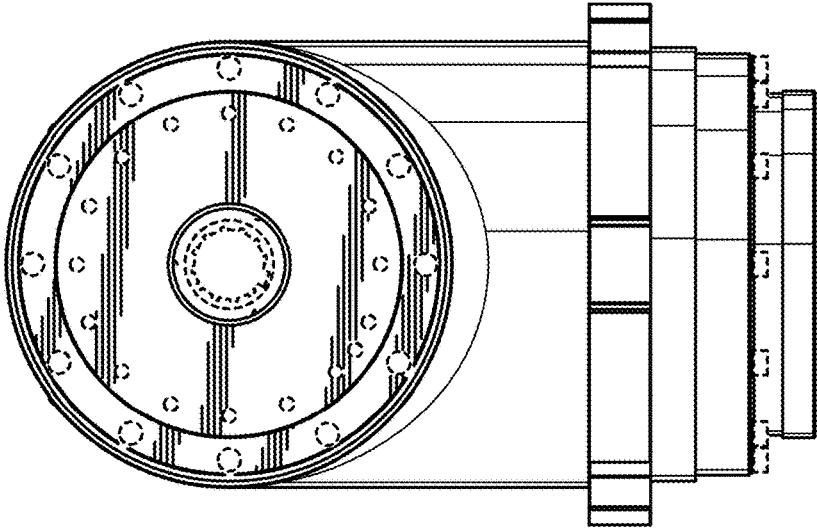

FIG. 3

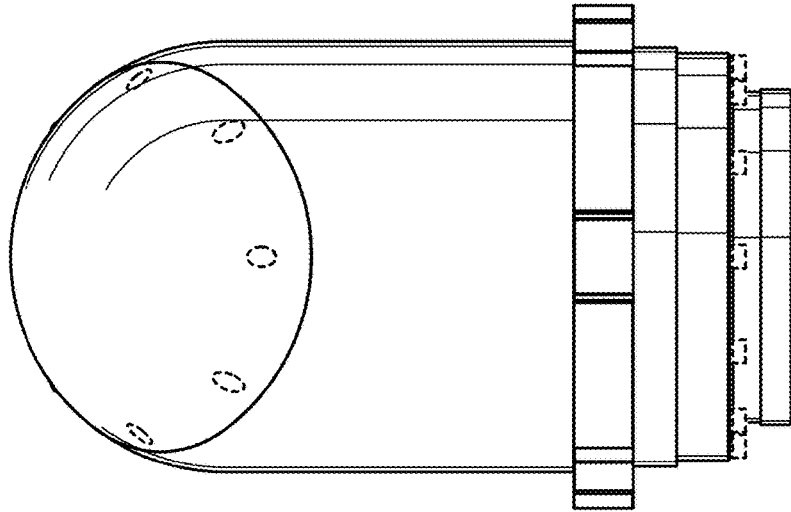

FIG. 5

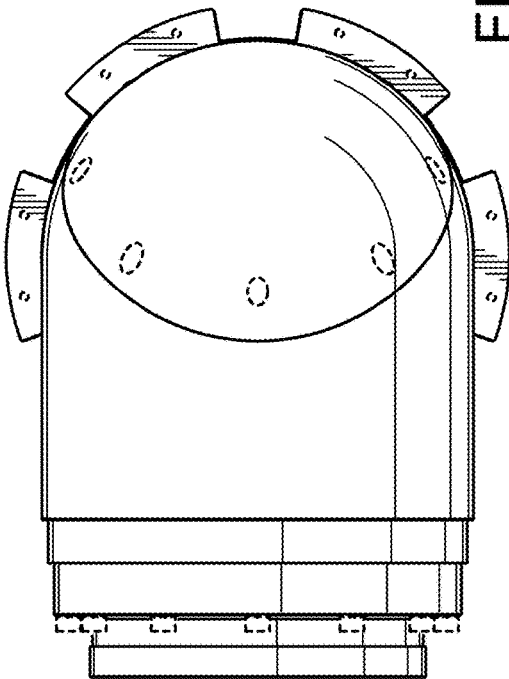

FIG. 4

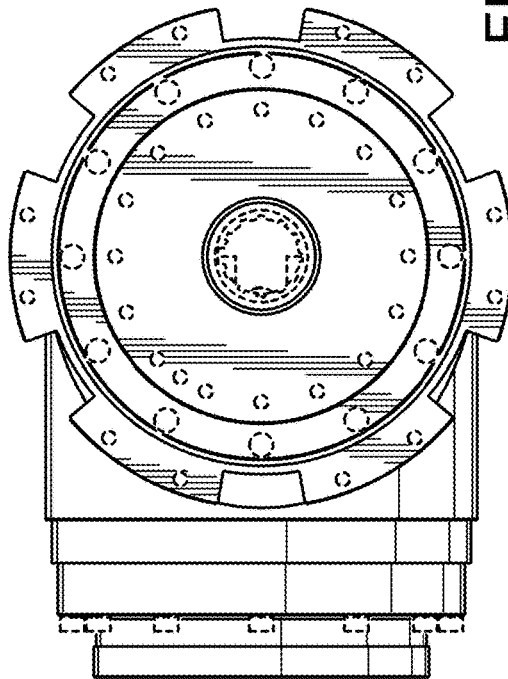

FIG. 6