

March 8, 1960

V. McDERMOTT
SQUEEZE BOTTLE VALVE

2,927,717

Filed May 7, 1958

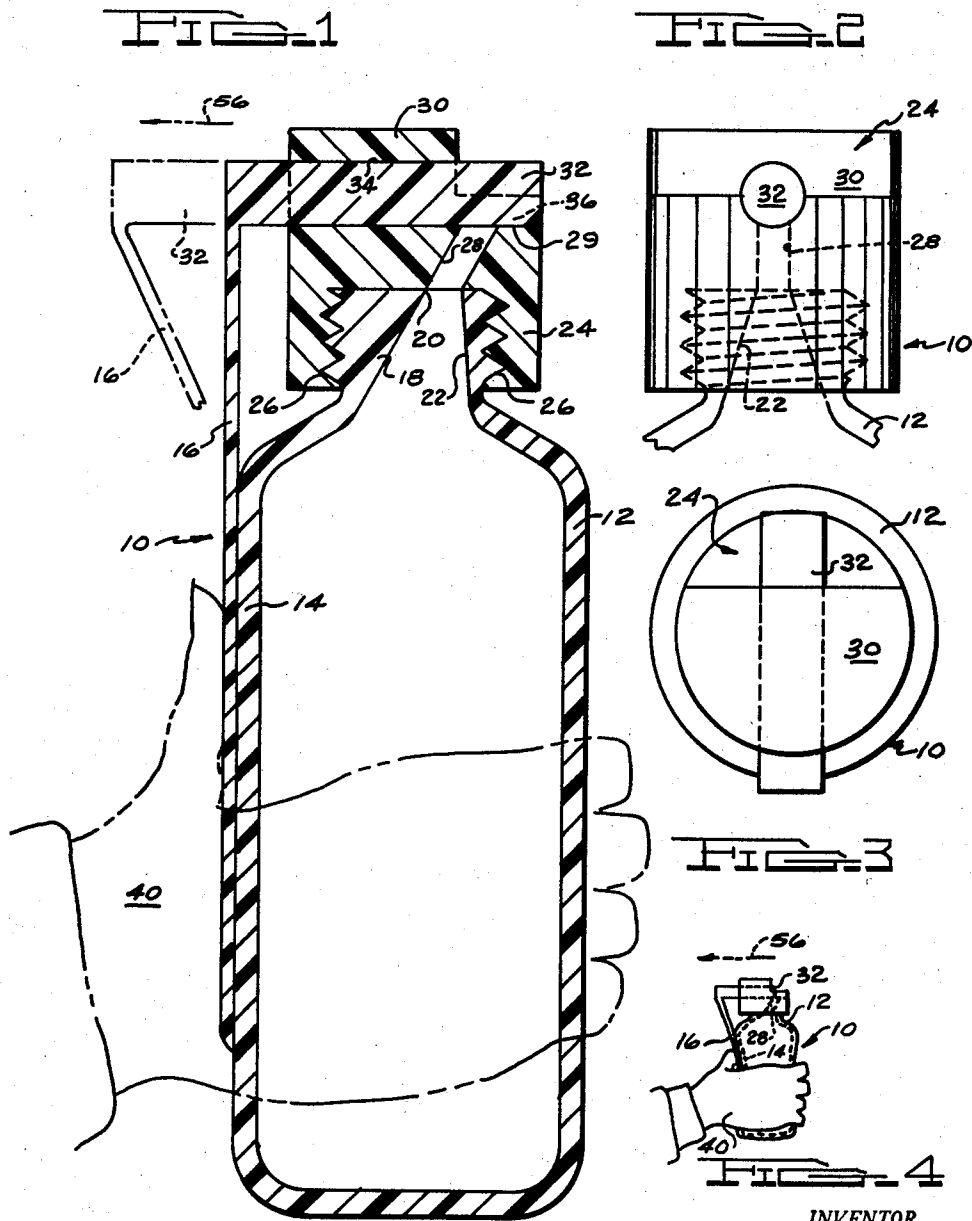

INVENTOR.
VINCENT McDERMOTT
BY
SMITH, WILSON, LEWIS & McRAE

1

2

2,927,717

SQUEEZE BOTTLE VALVE

Vincent McDermott, Dearborn, Mich.

Application May 7, 1958, Serial No. 733,717

3 Claims. (Cl. 222-213)

This invention relates to a dispenser for flowable material, such as creams, pastes, liquids, granular substances and the like. More particularly the invention relates to such a dispenser provided with a valve for the discharge opening which will open automatically as the dispenser is squeezed.

It is an object of this invention to provide a dispenser having a movable valve element to seal the dispenser discharge opening.

It is another object of this invention to provide a dispenser having such a valve which is actuated to move out of its sealing position by means of an arm attached to the side of the dispenser.

It is another object of this invention to provide a dispenser having a flexible valve actuating arm attached to a flexible side wall of the dispenser which arm is adapted to deform and actuate the valve when the flexible side wall is deformed by squeezing.

It is a further object of the invention to provide such a device in which the valve element will automatically clean off the top surface after the dispenser has been used.

It is a further object to provide a dispenser which does not require a removable cap or other sealing means in addition to the movable valve element.

Another object is to provide a dispenser with such a movable valve element which may be produced at a very low cost.

Other objects of this invention will appear in the following description and appended claims, reference being had to the accompanying drawings forming a part of this specification wherein like reference characters designate corresponding parts in the several views.

In the drawings:

Fig. 1 is a sectional view of a dispenser constructed according to the present invention.

Fig. 2 is a front elevational view of the upper portion of the Fig. 1 embodiment.

Fig. 3 is a top plan view of the Fig. 1 embodiment.

Fig. 4 is a side elevational view of the dispenser of Fig. 1 showing the side walls being squeezed to actuate the valve element.

Before explaining the present invention in detail, it is to be understood that the invention is not limited in its application to the details of construction and arrangement of parts illustrated in the accompanying drawings, since the invention is capable of other embodiments and of being practiced or carried out in various ways. Also, it is to be understood that the phrasology or terminology employed herein is for the purpose of description and not of limitation.

Referring specifically to the drawings, Fig. 1 shows a dispenser 10 comprising a container 12 provided with a discharge opening 20 in the upper end wall structure 18. End wall structure 18 includes an annular neck portion which connects with a container side wall 14 at an angle thereto so as to form a fulcrum for the valve-operating arm 16, as will be apparent hereinafter. A valve element

32 is slidably mounted by means of a valve seating structure 24 on the upper end 18 to normally block off and seal the discharge opening 20. Valve-operating means comprising a flexible arm 16 are provided to connect the valve element 32 to the side wall portion 14 of the container 12 to the end that squeezing the container 12 will operate to deform the wall 14 and adjacent portion of the arm 16 inwardly whereby the upper portion of the arm 16 will move outwardly and carry the valve element 32 across the discharge opening 20 and out of its normal sealing position whereby the contents of the container 12 can flow therefrom.

The container 12 may be a circular bottle shape as shown or it may be provided in other desirable forms as will be obvious to one skilled in the art. It is preferably constructed of a flexible material such as a resilient plastic or rubber. However, it is only necessary that one portion of the wall 14 be flexible in order to operate the valve arm 16 attached thereto as will be hereinafter more fully explained. The interior of the container 12 may be provided with a funnel shaped portion 22 adjacent the discharge opening 20 to direct the contents of the container 12 towards and through the opening 20.

The opening 20 registers with a discharge passageway 28 provided in the valve seating structure 24. The valve seating structure 24 may be in the form of a detachable cap as shown, secured to the upper end 18 of the container 12 by means of the threaded portion 26. However, the seating structure 24 may be formed integrally with the container 12 if desired. The structure 24 is provided with a projection 30 adjacent the discharge passageway 28, the material above the passageway 28 being cut away to permit the contents of the container 12 to be removed after they have been ejected. A guideway 34 in the form of a transverse bore is formed in the projection 30 to receive the valve element 32. A groove 36 extends from the guideway 34 over the discharge passageway 28. The groove 36 serves to direct the travel of the valve element 32 and also to conform the surface 29 of the valve seating structure 24 to the shape of the valve 32.

The valve or slide element 32, as shown in Figs. 1 and 3 in its normally closed position, extends entirely across the seating structure 24 and for a short distance out of the guideway 34 so as to be substantially flush with the side wall 14 of the container 12. The valve element 32 preferably has a curvilinear cross-sectional contour as shown so as to seat securely in the groove 36 and form a fluid tight seal for the discharge opening of the passageway 28.

The valve operating arm 16 is secured to one end of the valve element 32 and extends downwardly therefrom. The lower portion of the arm 16 is secured to the flexible side wall 14 of the container 12. The arm 16 preferably extends past the mid-point of the container 12 in order to be sufficiently deformed to slide the valve element 32 clear of the discharge passageway 28 when the dispenser 10 is squeezed. The arm 16 may be made integrally with the container wall 14 as a rib portion or it may be secured to the wall 14 by means of an adhesive material. The arm 16 may also be inset into the wall 14 so as to be almost flush therewith with only a small portion projecting outwardly in order to provide a smoother container 12 side wall surface.

The operation of the dispenser 10 is shown in Fig. 4 and indicated in phantom in Fig. 1. The dispenser 10 is squeezed by means of a hand 40 to move the wall 14 inwardly. This motion forces the upper portion of the arm 16 to fulcrum about the shoulder formed at the juncture between side wall structure 14 and end wall structure 18. Thus motion of arm 16 carries the valve element 32 across the top of the container 12 in the arrow

56 direction so as to open the discharge passageway 28 and allow the contents of the container 12 to flow out of the top. The squeezing action will also force the contents of the container 12 up into the funnel portion 22 and on out of the dispenser 10. When the pressure on the container 12 is removed, it will resume its formed shape and the arm 16 and valve element 32 will move to their at rest positions. The movement of the valve element 32 back across the entire length of the groove 36 will operate to scrape any excess material off the top of the container 12 thus keeping the top at all times clean.

As can be seen, the dispenser 10 is operative without an additional sealing element. Thus it is not required that a cap or other device be removed preliminary to ejecting a portion of the contents of the container 12. Furthermore the construction of the dispenser 10 is such that it can be produced as a very low cost item, since it can be molded or cast from inexpensive materials and does not require a complicated assembly operation.

Having thus described my invention, I claim:

1. The combination comprising a container comprising an annular end wall structure having a discharge opening; and a tubular flexible side wall structure extending from said end wall structure; the juncture of said end wall and said side wall forming a shoulder; the combination further comprising a valve element slidably mounted on the container end wall structure to move across the discharge opening, and a valve element operator arm extending between the side wall structure and valve element with a portion thereof lying against the aforesaid

shoulder; whereby when the flexible side wall is grasped in the users hand and a squeezing pressure applied thereto, said shoulder will form a fulcrum for causing the operator arm to pivot thereabout and withdraw the valve element from a position blocking the discharge opening.

2. The combination of claim 1 wherein the container side wall is resiliently biased so as to automatically return to its unsqueezed condition upon release of the squeezing pressure.

3. The combination of claim 1 wherein the container end wall structure defines a head having a pair of side surfaces and a guide bore extending therethrough in a direction generally transverse to the direction of the discharge opening; said valve element taking the form of a plunger slidably carried within the guide bore, with the tip thereof located to travel across the discharge opening and into alignment with one of the head side surfaces upon release of squeezing pressure on the container side wall, whereby to force material from the discharge opening toward said one head side surface and thence away from the container.

References Cited in the file of this patent

UNITED STATES PATENTS

1,199,522	Bigoney -----	Sept. 26, 1916
2,357,544	France -----	Sept. 5, 1944
2,667,287	Cook -----	Jan. 26, 1954